

User's Guide

for type ACS55
AC Drives
from 0.18 to 2.2 kW

English

EN



List of related manuals

Drive manual	Code
<i>ACS55 User's Guide</i>	3AFE68929300
<hr/>	
PC tool guide	
<i>DriveConfig User's Guide</i>	3AFE68910897
<hr/>	
Maintenance instruction	
<i>Guide for Capacitor Reforming</i>	3AFE68735190

Product and service inquiries

Address any inquiries about the product to your local ABB representative, quoting the type designation and serial number of the unit in question. A listing of ABB sales, support and service contacts can be found by navigating to www.abb.com/drives and selecting *Sales, Support and Service network*.

Product training

For information on ABB product training, navigate to www.abb.com/drives and select *Training courses*.

Providing feedback on ABB Drives manuals

Your comments on our manuals are welcome. Go to www.abb.com/drives, then select *Document Library – Manuals feedback form (LV AC drives)*.

3AFE68929300 Rev C
EN
Effective: 2010-04-12

ABB Oy
Drives
P.O. Box 184
FI-00381 HELSINKI
FINLAND
Telephone +358 10 22 11
Fax +358 10 22 22681
Internet www.abb.com/drives

Safety instructions

Read the following instructions carefully before proceeding with the installation.

Warning! Dangerous voltage!

Only a competent electrician may install ACS55.

Never work on the drive, the motor cable or the motor when main power is applied. After switching off the input power, always wait at least for 5 minutes to let the intermediate circuit capacitors discharge before you start working on the drive.

Warning! If the heat sink is not earthed properly, you can get an electric shock if you touch the heat sink.

Note: DIP switches are at a dangerous voltage.

Note: Even when the motor is stopped, dangerous voltages are present at power circuit terminals L/R, N/S, T1/U, T2/V and T3/W.

Note: Even when the unit is powered down, there may be dangerous external voltages connected from outside to the relay output terminals.

Warning! Hot surfaces!

During operation, the cooling element may reach high temperature (>80°C). Make sure to follow the installation instructions.

General safety instructions

ACS55 starts the motor automatically after a supply break if the external start signal is on.

Never attempt to repair a broken unit. ACS55 is not a field repairable unit. Contact the supplier for replacement.

Install ACS55 in a locked or tool-openable space.

Do not connect input power to the unit more than once every three minutes.

Altering the DIP switches will affect the function and performance of ACS55. Check that the changes will not cause any risk to persons or property.

About this manual

This guide provides information necessary to install and start-up the unit.

Delivery check

The delivery includes:

1. ACS55
2. User's Guide
3. Two clamps for the control cable (EMC units only).

Check the rating plate and ensure that the delivered device corresponds to the order.

ABB ACS55-01E-09A8-2	
IP20	
U1 1~200..240V	U2 3~0..U1
f1 50/60Hz	f2 0..250Hz
I1 22.0 A	I2 9.8A
Pn motor: 2.2 kW (3 HP)	
S/N MYYWWRXXXX	
3AFE XXXXXXXX	
CE	RoHS
Made in China	

ACS55-01 - -

EMC filter: E = Built in, N = No

Max. continuous output current (I_2):

01A4 = 1.4 A, 02A2 = 2.2 A, 04A3 = 4.3 A,
07A6 = 7.6 A, 09A8 = 9.8 A

Supply voltage (U_1):

1 = 110...120 VAC +10%/-15%
2 = 200...240 VAC +10%/-15%

Serial number (S/N) is printed on the rating plate.

(M = manufacturing location, YY = manufacturing year, WW = manufacturing week, R = product revision number (A, B, C...), XXXX = integer starting every week from 0001)

Overview of the unit

ACS55 drive controls the speed of a 3-phase AC induction motor.

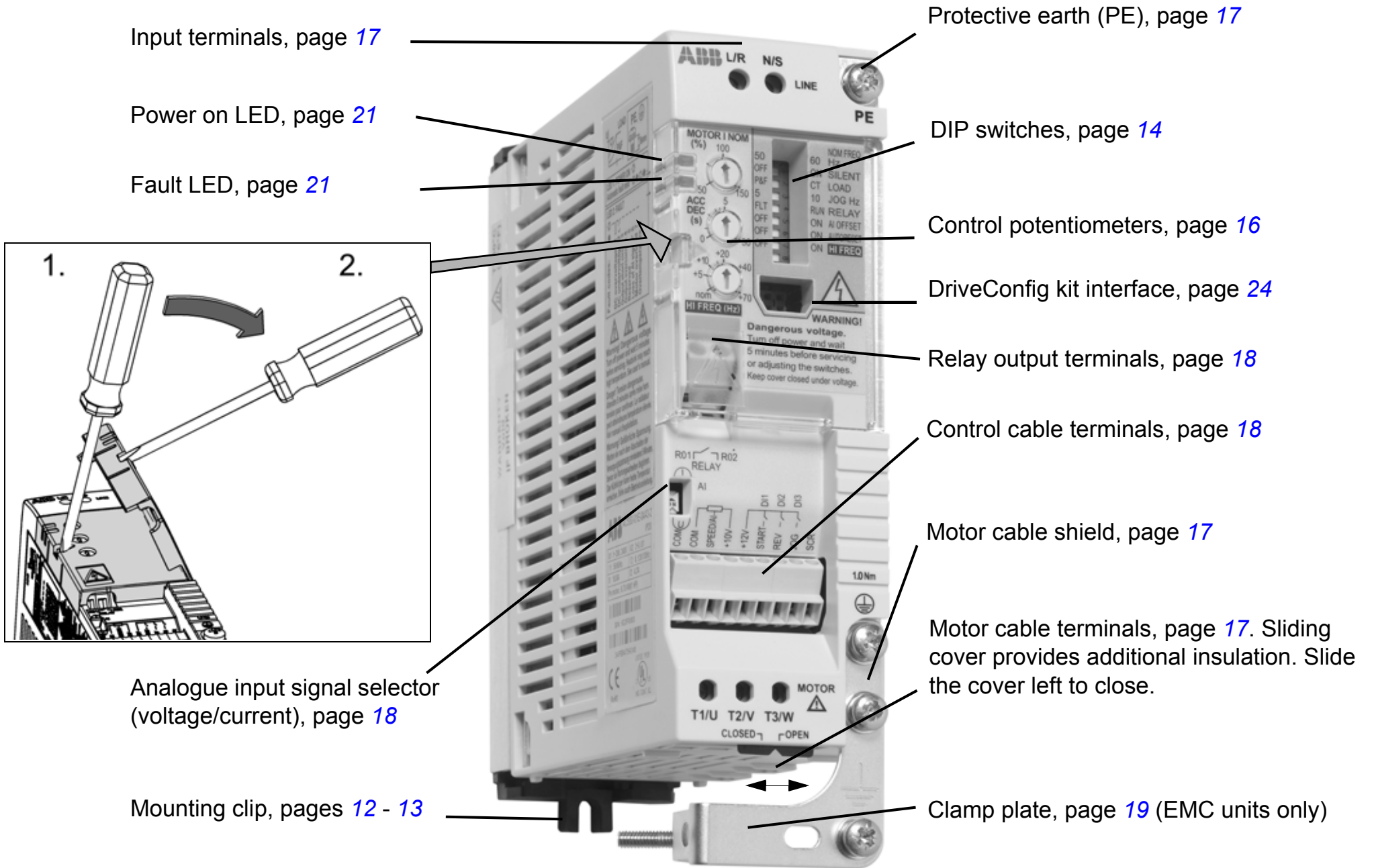

Installation and start-up steps

Read [Safety instructions](#) on page 7 before proceeding.

	Action	Pg.
1	Check the delivery.	7
2	Ensure that the installation environment is suitable for ACS55.	10
3	Mount the unit.	12 - 13
4	Check applicability of the standard settings: Motor nominal frequency is 50 Hz; load is a pump or a fan; maximum output frequency is 50 Hz. If the standard settings are not suitable, adjust the DIP switches.	14
5	Make sure the MOTOR I NOM potentiometer matches the rated current of the motor. It defines operation of the motor thermal protection function.	16
6	Adjust the acceleration/deceleration time potentiometer ACC/DEC if necessary.	16
7	Connect the power supply cable and motor cables.	17
8	Connect the control wires.	18
9	Turn the power on. Green LED is illuminated. Note: Motor rotates if the start signal is active.	
10	Set the speed reference and activate the start signal. The motor accelerates to the given speed reference.	20

Checking the insulation of the assembly

Do not make any voltage tolerance or insulation resistance tests (for example hi-pot or megger) on any part of the drive as testing can damage the drive. Every drive has been tested for insulation between the main circuit and the chassis at the factory. Also, there are voltage-limiting circuits inside the drive which cut down the testing voltage automatically.

Environmental limits

	Installation site	Storage and transportation in a protective package	
Air temperature	-20°C (-4°F), no frost allowed ¹⁾ +40°C (104°F), with nominal load +50°C (122°F), if continuous output current is max. 85% of the nominal output current I_2 +55°C (131°F), if continuous output current is max. 75% of the nominal output current I_2	-40°C (-40°F) to +70°C (158°F)	
Altitude	0...2000 m (0...6,600 ft). At altitudes 1000...2000 m (3,300...6,600 ft), P_N and I_2 are decreased by 1% for every 100 m.	No limitation	
Relative humidity	Less than 95%, non-condensing	Less than 95%, non-condensing	
Contamination levels (IEC 60721-3-3)	<ul style="list-style-type: none"> No conductive dust allowed Air must be clean, free from corrosive materials and conductive dust Chemical gases: Class 3C2 Solid particles: Class 3S2 	Storage	Transportation
		<ul style="list-style-type: none"> No conductive dust allowed Chemical gases: Class 1C2 Solid particles: Class 1S2 	<ul style="list-style-type: none"> No conductive dust allowed Chemical gases: Class 2C2 Solid particles: Class 2S2
Sinusoidal vibration (IEC 60068-2-6)	Frequency range: 5...150 Hz Constant peak acceleration: 1 g	In accordance with ISTA 1A specification	
Shock (IEC 60068-2-29)	Not allowed	Max. 100 m/s ² (330 ft/s ²), 11 ms (36 fts)	
Free fall	Not allowed	Not allowed	

1) When operating the drive in subzero temperatures, keep the input power connected. Install the drive inside an enclosure. Ensure that heat generated by the drive will be properly dissipated.

Degree of protection of ACS55 is IP20.

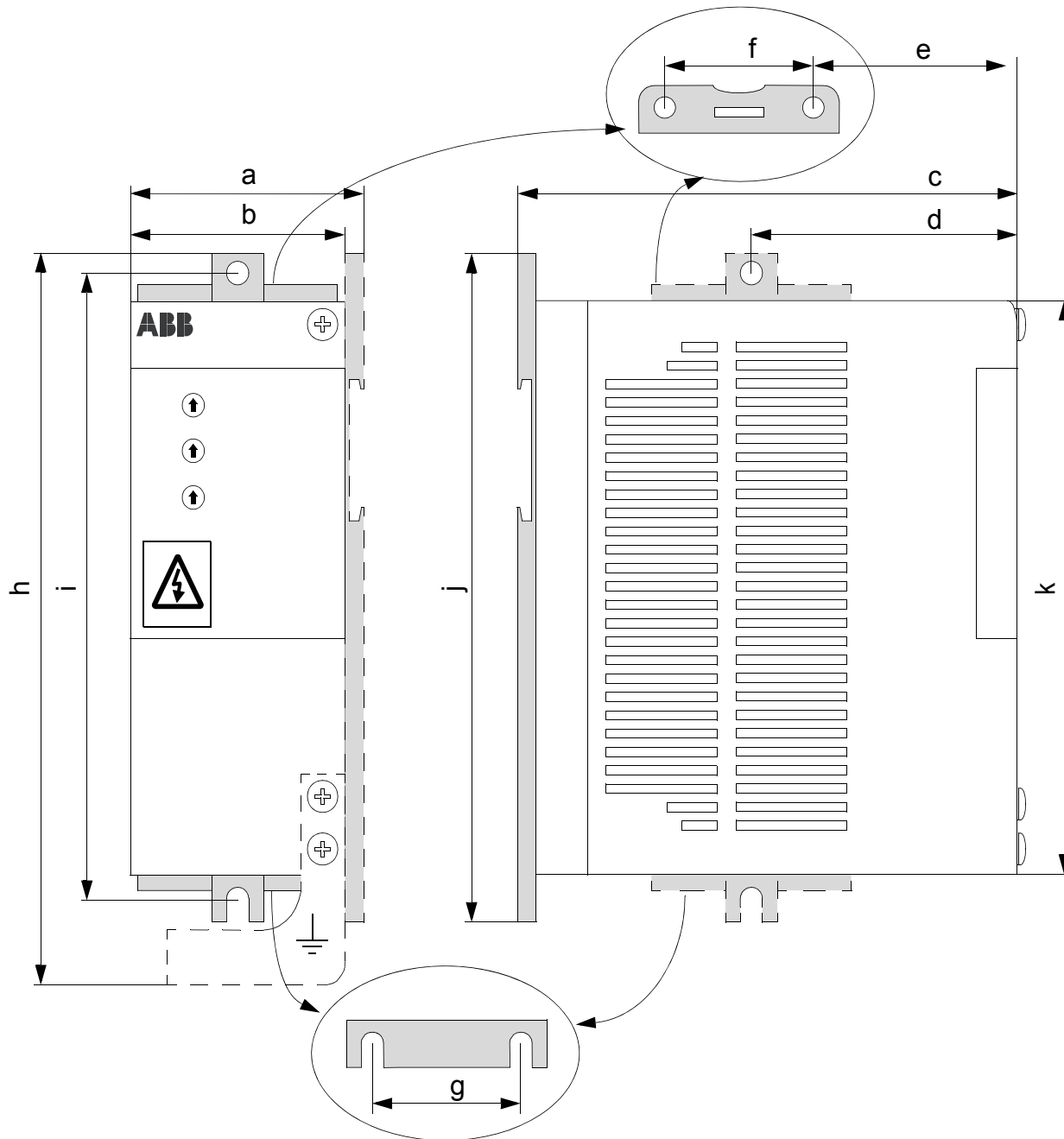

	Frame A mm (in.)	Frame B mm (in.)	Frame C mm (in.)	Frame D mm (in.)
a	53 (2.09)	72 (2.83)	74 (2.91)	74 (2.91)
b	45 (1.77)	67.5 (2.66)	70 (2.76)	70 (2.76)
c	128 (5.04)	128 (5.04)	159 (6.26)	159 (6.26)
d	67.5 (2.66)	67.5 (2.66)	-	-
e	-	-	77 (3.03)	77 (3.03)
f	-	-	40 (1.57)	40 (1.57)
g	-	-	40 (1.57)	40 (1.57)
h	183 (7.20)	183 (7.20)	-	230 (9.06)
i	156 (6.14)	156 (6.14)	182 (7.17)	214 (8.43)
j	170 (6.69)	170 (6.69)	194 (7.64)	226 (8.90)
k	146.5 (5.77)	146.5 (5.77)	171 (6.73)	203 (7.99)

Mounting

Warning! The unit will warm up to high temperature during normal operation. Ensure sufficient cooling air flow in all conditions:

- Always install ACS55 so that cooling fans are vertical.
- Leave sufficient space around frame A and B units. Frame C and D units are fan cooled, so they can be installed side by side without extra space between them.

Install the unit using the mounting clip on a 35 mm DIN rail or on a wall.

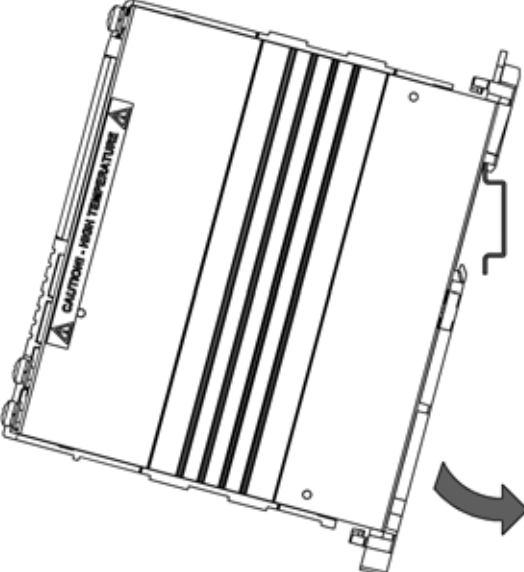
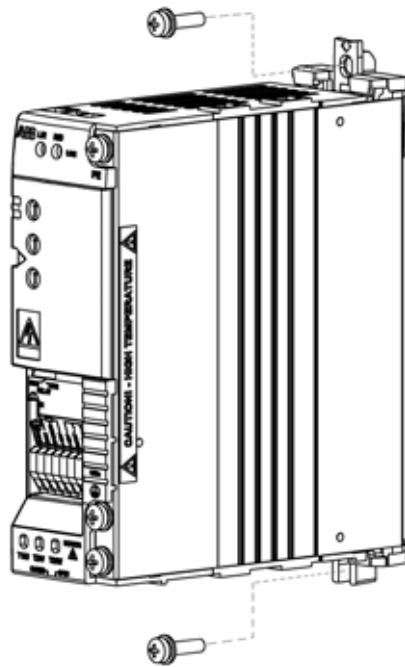
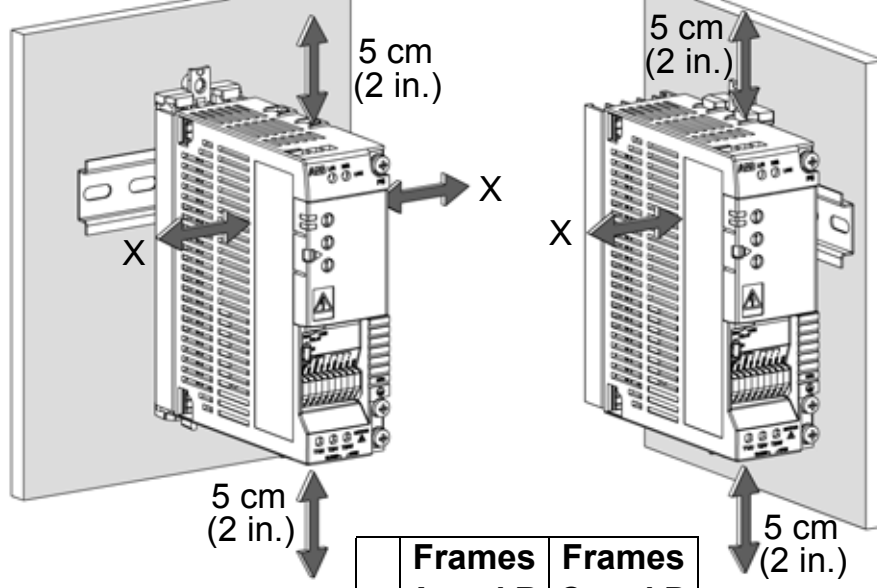
Mounting on DIN rail "Click" ACS55 to the rail. Press the lever on top of the mounting clip to detach.	Mounting on wall Install the unit onto the wall through the mounting clip. Use M4 screws.	Clearance distances Always leave sufficient space around the unit to ensure proper cooling.						
		 <table border="1" data-bbox="1590 1260 1937 1444"> <thead> <tr> <th></th> <th>Frames A and B cm (in.)</th> <th>Frames C and D cm (in.)</th> </tr> </thead> <tbody> <tr> <td>X</td> <td>1.5 (0.6)</td> <td>0 (0)</td> </tr> </tbody> </table>		Frames A and B cm (in.)	Frames C and D cm (in.)	X	1.5 (0.6)	0 (0)
	Frames A and B cm (in.)	Frames C and D cm (in.)						
X	1.5 (0.6)	0 (0)						

Attaching and detaching the wall mounting clip

The unit can be mounted either with the wide or the narrow side against the wall. Install the mounting clip on the desired side. See instructions below for frames A and B. Detach the mounting clip of frames C and D by pulling downward and attach it by pushing upward.

Detaching the mounting clip, Frames A and B: Press the two plastic buttons to detach the upper and lower part of the clip from each other.

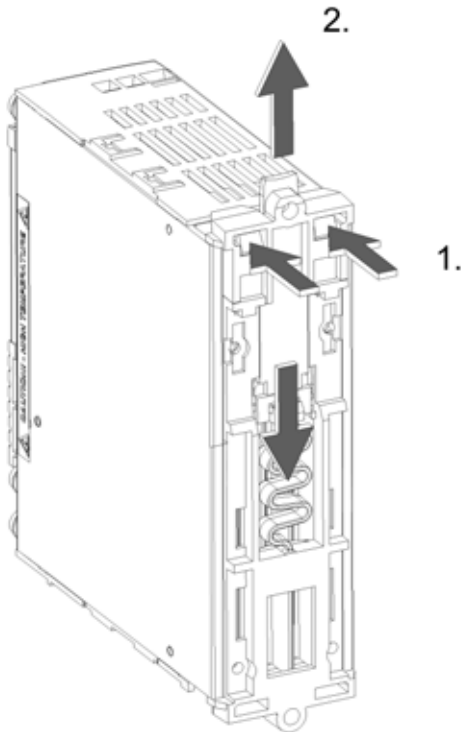

Attaching the mounting clip, Frame A: Place the two parts as shown and click them together.

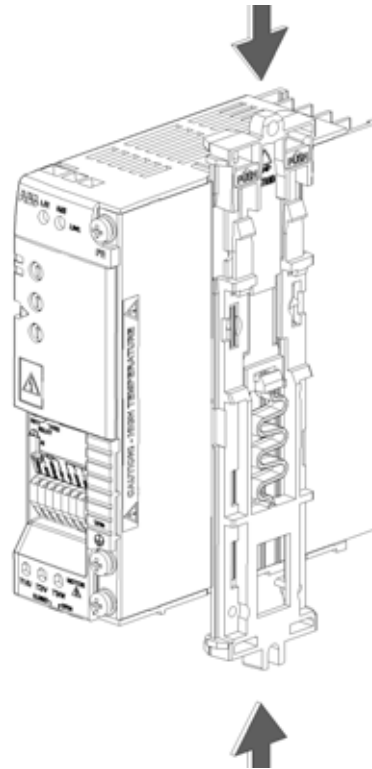

Attaching the mounting clip, Frame B: Push the two parts between the cooling fins and click them together.

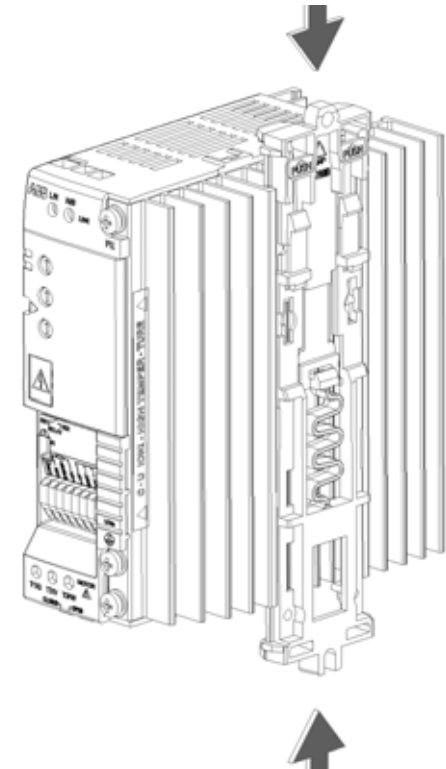

DIP switches

DIP switches are used to adapt ACS55 to the motor and the application.





Warning! The DIP switch is at a dangerous voltage (200 V). Turn off power and wait for 5 minutes before adjusting the switches. Keep the protective cover closed when ACS55 is powered.

Configuration

- Open the front cover using the tip of a screwdriver, and adjust the DIP switches.
- Use the tip of a screwdriver to slide the switch to the left or right. By default, all switches are in their left position.
- Close the front cover.

Basic information

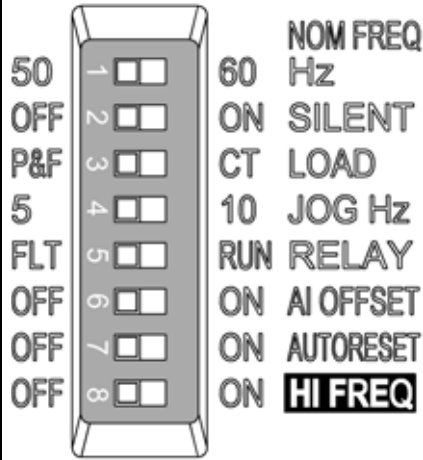
DIP switch	#	Name and function	Default setting 	Alternative setting 
	1	NOM FREQ HZ: Motor nominal frequency	50 Hz	60 Hz
	2	SILENT: Motor noise level (PWM switching frequency)	OFF - Normal (5 kHz)	ON - Silent (16 kHz)
	3	LOAD: Load torque type (U/f curve)	P&F - Pump/fan	CT - Constant torque
	4	JOG HZ: Constant frequency for the jogging function	5 Hz	10 Hz
	5	RELAY: Relay output operation	FLT - Fault	RUN - Motor running
	6	AI OFFSET: Minimum value for analogue input	OFF - 0 mA (0 V)	ON - 4 mA (2 V)
	7	AUTORESET: Automatic fault reset function	OFF - No autoreset	ON - Autoreset enabled
	8	HI FREQ: High frequency mode	OFF - Standard	ON - High frequency enabled

Additional information

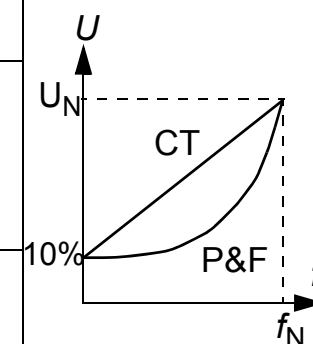

No.	Name	Information
1	NOM FREQ Hz	Defines the motor nominal frequency (see the motor rating plate).
2	SILENT	Defines the drive switching frequency. Note: The higher the frequency the more electromagnetic noise and the shorter the allowed motor cable length to comply with the European EMC regulations. See Technical data on page 22. Note: The switching frequency adapts to the ACS55 temperature.
3	LOAD	Optimises the output voltage and frequency characteristics according to the load. Select P&F for the squared torque (e.g. pumps and fans) and CT for the constant torque loads (e.g. conveyors). ACS55 automatically boosts the starting voltage 10% to compensate the motor losses and to increase the starting torque.
4	JOG Hz	Defines the jogging frequency. Activate the jogging function on by connecting 12...24 VDC to digital input 3 ("JOG"). (Drive accelerates or decelerates to the jogging frequency, and keeps it until the input is switched off.)
5	RELAY	Selects the drive state the normally open contact of the relay output indicates. FLT = Fault. Contact is opened while at a fault state or at a power off state. RUN = Running. Contact is closed while running.
6	AI OFFSET	Activates a living zero supervision for the analogue input. 4 mA (2 V) = ACS55 trips on a fault if the value drops below the limit. See section Speed controlling on page 20 for information on analogue input scaling.
7	AUTO- RESET	Activates the automatic reset function for the following faults: Undervoltage, overvoltage, analogue input loss. ON = ACS55 will try to reset automatically three seconds after a fault trip. Maximum number of resets is ten in three minutes. If exceeded, ACS55 stops and will not attempt a new reset. See also Status indications and fault tracing on page 21. Warning! If the start signal is on, the motor will be started after a reset. Make sure that this will not cause danger.
8	HI FREQ	Defines the maximum output frequency. OFF: Max. frequency = value defined by the NOM FREQ HZ switch. ON: Max. frequency = value defined by the NOM FREQ HZ switch + value of HI FREQ potentiometer. See Control potentiometers on page 16.



For more information, see *DriveConfig User's Guide* [3AFE68910897 (English)].

Control potentiometers

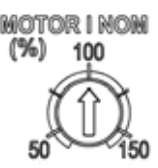
The control potentiometers can be adjusted using a screwdriver. By default, all potentiometers are in their middle position.

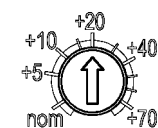
 <p>MOTOR I NOM (%)</p>	<p>MOTOR I NOM</p>	<p>Calculate MOTOR I NOM with the equation below or pick a value from the MOTOR I NOM selection chart below. ACS55 estimates the temperature of the motor based on the measured output current and the defined motor nominal current. The drive trips if the estimated temperature implies motor overheating. Note: If motor cables are long causing large capacitive currents, it might be necessary to increase the MOTOR I NOM setting.</p> $\text{MOTOR I NOM (\%)} = \frac{\text{Motor nominal current [A]}}{\text{ACS55 nominal current [A]}} \cdot 100\%$
 <p>ACC/DEC (s)</p>	<p>ACC/DEC</p>	<p>Defines the acceleration and deceleration time from minimum to maximum frequency and vice versa in seconds. The longer the ACC/DEC time, the more slowly ACS55 will follow the given reference.</p>
 <p>HI FREQ (Hz)</p>	<p>HI FREQ</p>	<p>Limits the output frequency to a desired value between nominal frequency and nominal frequency + 70 Hz. To use this potentiometer, turn the high frequency mode on with the HI FREQ DIP switch. See DIP switches on page 14.</p>

MOTOR I NOM selection chart

Motor nominal current (A)

ACS55-01x-

-01A4-x	0,7	0,8	1,0	1,2	1,4	1,6	1,8	2,0	2,1		
-02A2-x	1,1	1,3	1,5	1,8	2,0	2,2	2,4	2,6	2,8	3,0	3,3
-04A3-x	2,2	2,6	3,0	3,5	4,0	4,3	4,7	5,2	5,6	6,0	6,5
-07A6-x	3,8	4,6	5,3	6,1	6,8	7,6	8,4	9,3	10,2	11,4	
-09A8-x	4,9	5,9	6,9	7,8	8,8	9,8	10,8	12,0	13,3	14,7	

MOTOR I NOM 50 60 70 80 90 100 110 120 130 140 150%

ACC/DEC time

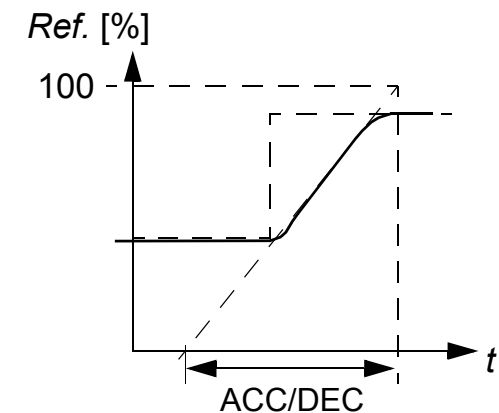

Connecting power supply and motor

1-phase
input voltage

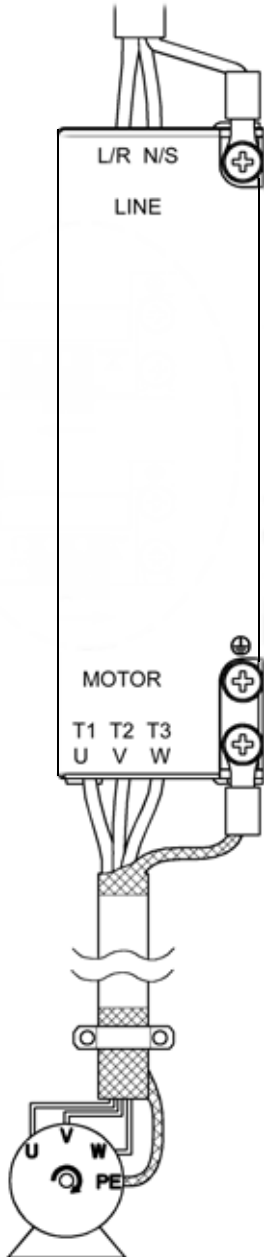

Warning! Before installation ensure that the main supply is off.

Note: Ensure power supply is correct! Connecting 230 VAC to the ACS55 unit rated for 115 VAC input will damage the drive!

Terminal	Description	Wire size	Tightening torque
L/R, N/S	1~ power supply input	Max. 2.5 mm ² (frames A and B) or max. 4 mm ² (frames C and D) four conductor cable	0.5 N·m
T1/U, T2/V, T3/W	Power output to motor		
PE 	Protective earth. Motor cable protective conductor and shield.	Use multi-strand copper wire. Size of the wire is not allowed to be smaller than the size of the power cable used.	1 N·m

Warning! If the heat sink is not earthed properly, you can get an electric shock if you touch the heat sink.

Note: Use only supplied M4x8 Combi screws. Maximum allowed intrusion depth for the grounding screws is 6 mm.

Follow local rules for cable cross sections. Use 60°C (140°F) rated power cable, or 75°C (167°F) rated cable if ambient temperature is above 30°C (86°F). See also [Additional cabling and EMC instructions](#) on page 19.

Earth leakage current of the ACS55 can exceed 3.5 mA AC / 10 mA DC. According to EN50178, ACS55 may only be used in permanent installation.

Input fuse

See [Technical data](#) on page 22 for recommended fuse types.

Motor

The motor must be a 3-phase AC induction motor, with nominal voltage U_N from 200 to 240 V and nominal frequency f_N either 50 or 60 Hz. Motor nominal current must be less than or equal to the nominal output current (I_2) of the drive.

If the phases are connected, U-U, V-V and W-W, and the selected direction is forward, the shaft rotates clockwise as seen from the drive shaft end.

Connecting control wires

Internal (1) or external (2) power supply can be used for the digital inputs. Analogue control voltage is 0...10 VDC as default. (The AI jumper must be in voltage ("U") position).

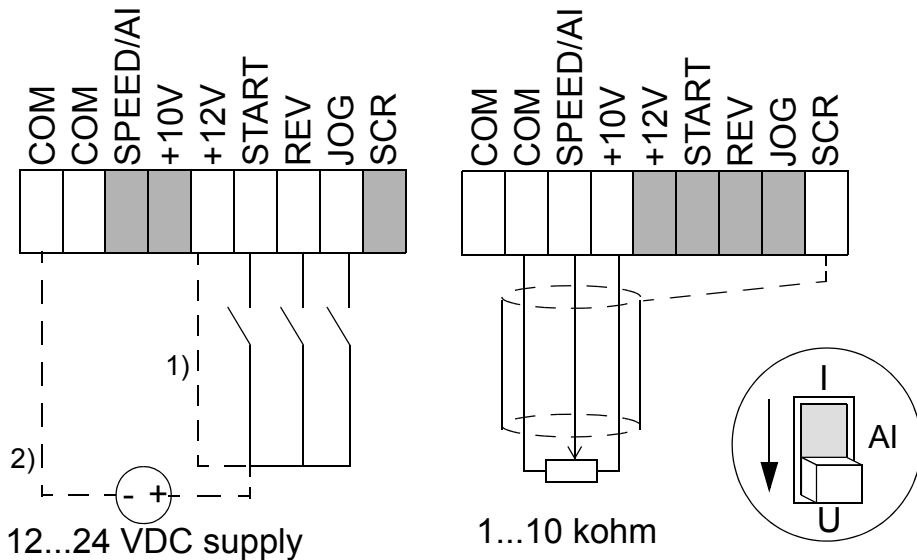

Using 0/4...20 mA current signal:

- Change AI jumper to current ("I") position.
- Set AI OFFSET switch to ON position if 4...20 mA current signal is desired.

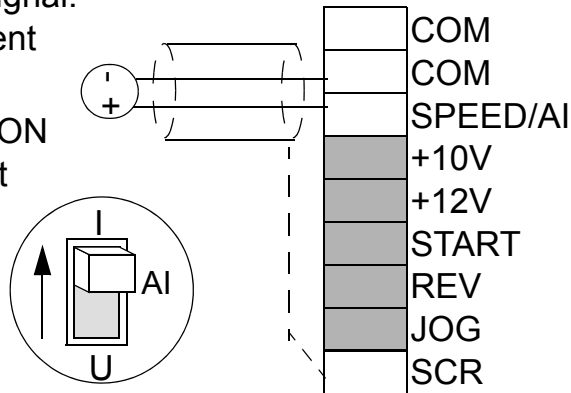

Control terminals

- Conductor size: stranded 0.25...1.5 mm² (AWG 23 to AWG 16)
- Tightening torque: 0.25 N·m.

#	Name	Description
1	COM	Common for digital or analogue inputs ¹⁾
2	COM	Common for digital or analogue input ¹⁾
3	AI	Analogue input: Speed (frequency) reference. 0/2...10 VDC (R _i =190 kohm), or 0/4...20 mA (R _i =100 ohm). Resolution 0.1%, accuracy +/-1%.
4	+10V	Reference voltage for analogue input. Accuracy +/-2%. Max. 10 mA.
5	+12V	Auxiliary voltage for digital inputs. Max. 30 mA.
6	START	Digital input 1: Start (resets the drive after a fault trip) ²⁾
7	REV	Digital input 2: Reverse rotation direction ²⁾
8	JOG	Digital input 3: Activate jog speed ²⁾
9	SCR	Earth for signal cable screen. Connected internally to frame earth.
Relay output		
1	RO1	Fault: Relay opens. 12 V...250 VAC / 30 VDC 10 mA...2 A
2	RO2	

- 1) Connected internally to frame (earth) through 1 Mohm resistor.
- 2) Digital input impedance is 1.5 kohm.

Additional cabling and EMC instructions

Follow these instructions for trouble free operation and to ensure compatibility with the European EMC directive.

Motor cable

The motor cable must be a symmetrical three conductor cable with a concentric PE conductor or a four conductor cable with a concentric shield. Braided metallic screen is recommended, e.g. type MCCMK (NK Cables).

- Twist the cable screen wires together into a bundle, and connect to the earthing terminal \perp . Keep the bundle as short as possible.
- Clamp the cable screen as shown in the figure when internal or external EMC filter is used.
- At the motor end the motor cable screens must be earthed 360 degrees with an EMC cable gland or the screen wires must be twisted together into a bundle not longer than 5 times its width and connected to the PE terminal of the motor.

Control cables

Control cables must be multi-core cables with a braided copper wire screen. A double shielded twisted pair cable is recommended for the analogue signals.

- Twist the screen together into a bundle and connect to terminal SCR. Keep the bundle as short as possible.
- Clamp the control cable as shown in the figure (EMC units only).
- Route the motor cable away from the control wires and the power supply cable to avoid electromagnetic interference (distance > 20 cm).

Note: Never mix 24 VDC and 115/230 VAC signals in the same cable.

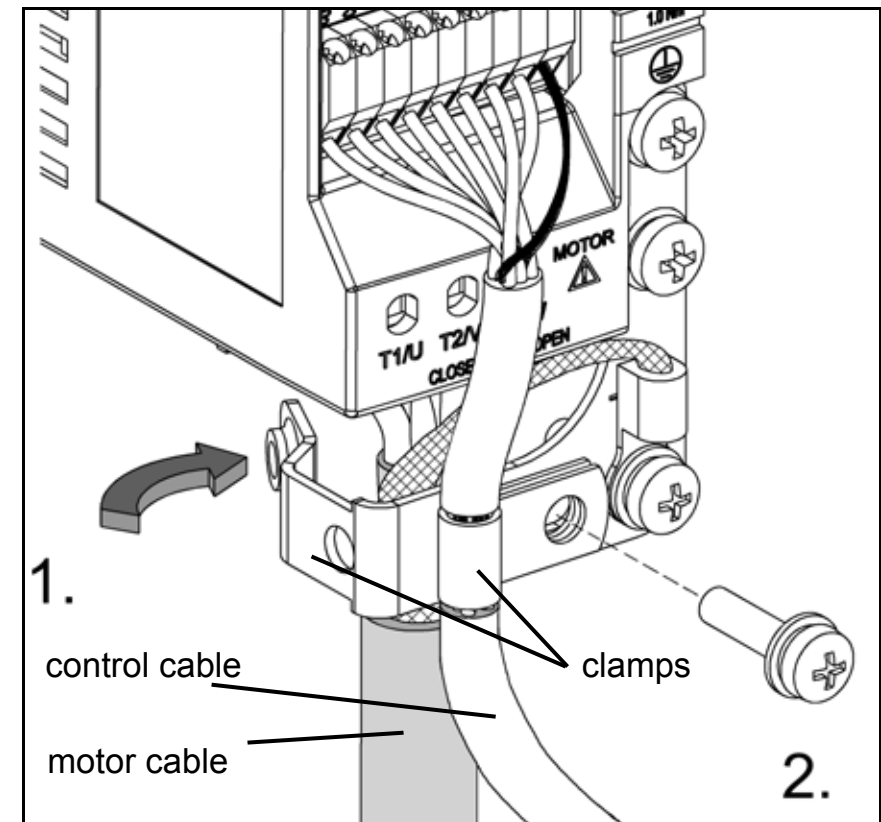

Speed controlling

The analogue input gives the speed (frequency) reference for ACS55. The correspondence between the analogue input and the reference depends on the settings of the DIP switches as shown below. Output frequency follows the reference changes as defined by the ACC/DEC potentiometer.

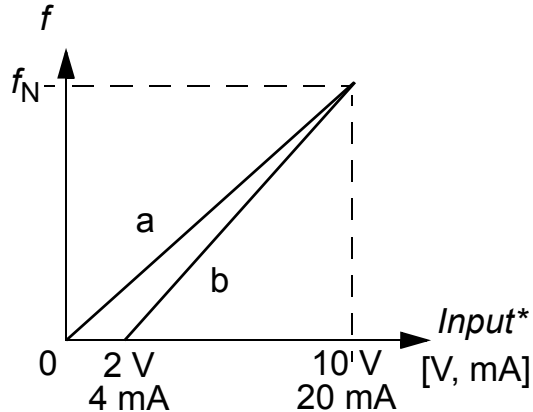
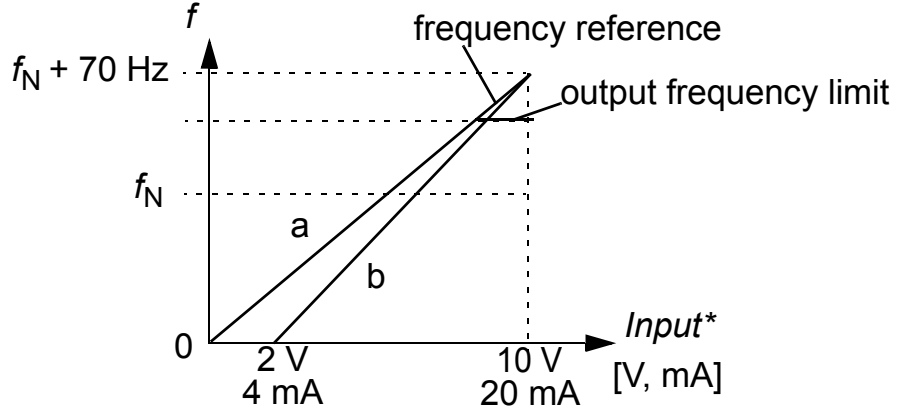
High frequency mode OFF (default)	High frequency mode ON
 <p>DIP switch settings: HI FREQ = OFF AI OFFSET = OFF (curve a) or ON** (curve b) MOTOR NOM FREQ = 50 or 60 Hz</p> <p>The output frequency is limited to the selected nominal frequency of the motor.</p>	 <p>DIP switch settings: HI FREQ = ON AI OFFSET = OFF (curve a) or ON** (curve b) MOTOR NOM FREQ = 50 or 60 Hz</p> <p>Actual output frequency is limited to a value between f_N and $f_N + 70$ Hz by the HI FREQ potentiometer. The potentiometer does not affect the scaling of the analogue input.</p>
<p>* Use AI jumper to select voltage or current signal. See page 18.</p> <p>** To protect the drive against analogue input signal loss, the drive trips if the signal value is below 2 V (4 mA).</p>	

Status indications and fault tracing

ACS55 has two status indication LEDs, visible through the front cover.

If the drive detects a problem, the red LED will blink. After fixing the problem, reset by switching the start signal off. If start is off already, turn it first on and then off again.

See the table below for the fault codes (= the number of LED blinks).

Green LED	Red LED	Description
On	Off	ACS55 operates normally.
On	Blinking On  Off	Protective function has been activated. Number of blinks indicates the fault code.
Blinking	Blinking	ACS55 will reset automatically within 3 seconds. (*) Warning! Motor starts, if start signal is on.

#	Possible causes and what to do	#	Possible causes and what to do
1	DC overvoltage (*). 1) Mains voltage is too high: Check supply. 2) Deceleration ramp time is too short compared to the load inertia: Increase ACC/DEC time with potentiometer.	7	Motor overload (I^2t overload): 1) Check the load, and verify that the motor size is suitable for ACS55. 2) Verify that setting of MOTOR I NOM potentiometer is correct.
2	DC undervoltage (*). Mains voltage is too low: Check supply.	8	Inverter overload or excessive internal temperature: 1) Load is too high or 2) drive cooling is insufficient.
3	Output short circuit: Switch off the power and check the motor windings and motor cable.	9	Other fault. Internal error. Turn power off and on again. If problem persists, replace the unit.
4	Output overcurrent. 1) Acceleration time is too short compared to the load inertia: Increase ACC/DEC time with potentiometer. 2) Motor and drive sizes do not match: Check motor.	10	Parameterization fault. Note: Both LEDs will blink. DIP switches have been moved from default setting after the drive has been parameterized with DriveConfig tool. Put the switches back to default position.
5	Reserved	11	Drive is battery-powered. Drive status indicates Fault, because it is not possible to start the drive. For drive operation, the drive must be connected to mains. However, when the drive is powered from the DriveConfig kit supply, the connection between DriveConfig and the drive is OK.
6	Analogue input value is less than 4 mA/2 V. (*) Note: This supervision is active if AI OFFSET is ON.	12	Drive has been controlled by DriveConfig (or other application via serial communication) and the communication has been lost. Check the communication.

(*) Automatically reset if the AUTORESET is ON. See [DIP switches](#) on page 14.

Technical data

		230 V					115 V	
Built-in EMC, ACS55-01E-		01A4-2	02A2-2	04A3-2	07A6-2	09A8-2	01A4-1	02A2-1
No EMC, ACS55-01N-		01A4-2	02A2-2	04A3-2	07A6-2	09A8-2	01A4-1	02A2-1
Motor continuous output power	kW	0.18	0.37	0.75	1.5	2.2	0.18	0.37
	hp	1/4	1/2	1	2	3	1/4	1/2
Frame size (no EMC)		A	A	B	C	C	A	A
Frame size (EMC)		A	A	B	D	D	A	A
Nominal ratings								
Input voltage U_1	V	200...240 (+10/-15%)					110...120 (+10/-15%)	
Continuous output current I_2	A	1.4	2.2	4.3	7.6	9.8	1.4	2.2
Max. output current I_{2max}^*	A	2.1	3.3	6.5	11.4	14.7	2.1	3.3
Output voltage U_2	V	0... U_1 , 3-phase					0... $2 \times U_1$, 3-phase	
Input current I_1	A	4.4	6.9	10.8	18.2	22.0	6.4	9.5
Switching frequency	kHz	5 (max. 16)						
Protection limits								
Overcurrent (peak)	A	4.4	6.9	13.5	23.9	30.9	4.4	6.9
Overtemperature		95°C / 203°F (heat sink)						
Maximum wire sizes								
Power terminals	mm ²	2.5 (AWG 14)			4 (AWG 12)		2.5 (AWG 14)	
Control terminals	mm ²	1.5 (AWG 16)						
Power losses	W	21	32	51	74	103	24	35
Line fuse size**								
IEC, type IEC269 gG	A	10	16	16	25	32	10	16
UL, types CC and T	A	10	15	20	25	30	10	15
Weight, Built-in EMC, ACS55-01E-	kg (lb)	0.65 (1.4)	0.7 (1.5)	0.9 (2)	1.6 (3.5)	1.7 (3.7)	0.65 (1.4)	0.7 (1.5)
Weight, No EMC, ACS55-01N-	kg (lb)	0.65 (1.4)	0.7 (1.5)	0.9 (2)	1.2 (2.6)	1.3 (2.9)	0.65 (1.4)	0.7 (1.5)

* Allowed for 1 minute.

** Recommended values. Do not use ultra rapid or low peak fuses. Follow local rules.

Maximum motor cable lengths

To comply with European EMC regulations, the motor cable length has to be limited as specified in the table below. The shorter the motor cable, the lower the noise emissions to the supply line and the environment.

Converter type ACS55-01x-	Switching frequency	
	5 kHz	16 kHz ¹⁾
Built-in EMC filter		
<i>EN61800-3, First environment, unrestricted distribution ²⁾</i>		
01A4-2, ..., 04A3-2	10 m	3 m
01A4-1, 02A2-1	10 m	3 m
07A6-2, 09A8-2	10 m	3 m
<i>EN61800-3, First environment, restricted distribution ³⁾</i>		
01A4-2, ..., 04A3-2	10 m	10 m
01A4-1, 02A2-1	10 m	10 m
07A6-2, 09A8-2	20 m	10 m
<i>EN61800-3, Second environment ³⁾</i>		
01A4-2, ..., 04A3-2	10 m	10 m
01A4-1, 02A2-1	10 m	10 m
07A6-2, 09A8-2	30 m	10 m

1) Switching frequency can be selected with the DIP switch. See page [15](#).

2) Applicable for conducted emissions only.

3) Applicable for conducted and radiated emissions.

Protections

Overvoltage, undervoltage, output short circuit, overcurrent, analogue input loss, motor overload, inverter overload.

Distribution networks isolated from earth

Drives with built-in EMC filter must not be used in a floating network or in a high impedance earthed industrial distribution network.

Environmental information

A product to be disposed contains valuable raw material that should be recycled, thus preserving energy and natural resources. Instructions for disposal are available from ABB sales and service companies.

Liability limits

The manufacturer is not responsible for:

- Any costs resulting from a failure if the installation, commissioning, repair, alteration or ambient conditions of the drive do not fulfil the requirements specified in the documentation delivered with the unit and other relevant documentation.
- Units subjected to misuse, negligence or accident.
- Units comprised of materials provided or designs stipulated by the purchaser.

In no event shall the manufacturer, its suppliers or subcontractors be liable for special, indirect, incidental or consequential damages, losses or penalties.

If you have any question concerning your ABB drive, please contact the local distributor or ABB office. The technical data, information and specifications are valid at the time of printing. The manufacturer reserves the right to modifications without prior notice.

Approvals

CE

The ACS55 complies with the requirements of the European

- Low Voltage Directive 73/23/EEC with amendments
- EMC Directive 89/336/EEC with amendments.

Corresponding declarations and a list of main standards are available on request.

Electromagnetic compatibility:

The ACS55 fulfils the following standards provided that installation is done properly and according to the instructions of this manual:

Conductive high frequency emissions	EN61800-3 first environment, unrestricted/restricted distribution ¹⁾
Radiated high frequency emissions	EN61800-3 first environment, restricted distribution
Immunity	EN61800-3 second environment
Line current harmonics	IEC61000-3-2

1) Observe the maximum allowed motor cable lengths and switching frequency, page 23. See also cabling instructions on page 19.

The current harmonic levels can be reduced by fitting external input chokes.

UL, cUL and C-Tick markings

See the rating plate.

UL, cUL:

The ACS55 is suitable for use on a circuit capable of delivering not more than 65 kA rms symmetrical amperes, 230 volts maximum, when protected by CC or T class fuses.

C-Tick:

For the electromagnetic compatibility, see the specification in section CE above.

Compliance with the European Machinery Directive

The drive complies with the European Machinery Directive requirements for an equipment intended to be incorporated into machinery. The declaration of incorporation is available from ABB.

Product protection in the USA

This product is protected by one or more of the following US patents

4,920,306	5,301,085	5,463,302	5,521,483	5,532,568	5,589,754	5,612,604
5,654,624	5,799,805	5,940,286	5,942,874	5,952,613	6,094,364	6,147,887
6,175,256	6,184,740	6,195,274	6,229,356	6,252,436	6,265,724	6,305,464
6,313,599	6,316,896	6,335,607	6,370,049	6,396,236	6,448,735	6,498,452
6,552,510	6,597,148	6,600,290	6,741,059	6,774,758	6,844,794	6,856,502
6,859,374	6,922,883	6,940,253	6,934,169	6,956,352	6,958,923	6,967,453
6,972,976	6,977,449	6,984,958	6,985,371	6,992,908	6,999,329	7,023,160
7,034,510	7,036,223	7,045,987	7,057,908	7,059,390	7,067,997	7,082,374
7,084,604	7,098,623	7,102,325	7,109,780	7,164,562	7,176,779	7,190,599
7,215,099	7,221,152	7,227,325	7,245,197	7,250,739	7,262,577	7,271,505
7,274,573	7,279,802	7,280,938	7,330,095	7,349,814	7,352,220	7,365,622
7,372,696	7,388,765	7,408,791	7,417,408	7,446,268	7,456,615	7,508,688
7,515,447	7,560,894	D503,931	D510,319	D510,320	D511,137	D511,150
D512,026	D512,696	D521,466	D541,743S	D541,744S	D541,745S	
D548,182S	D548,183S	D573,090S				

Other patents pending.

Accessories

Input chokes: CHK-A1, CHK-B1, CHK-C1, CHK-D1

Output choke: ACS-CHK-B3, ACS-CHK-C3

Potentiometer unit: ACS55-POT

DriveConfig kit, for more information please contact your local ABB office. See *DriveConfig User's Guide* [3AFE68910897 (English)].

Declaration of incorporation



ABB Inc.

Discrete Automation & Motion
Drives and Controls

16250 West Glendale Drive
New Berlin, WI 53151 USA

Telephone (800) 752-0696

3AFE68929300 Rev C
EN
EFFECTIVE: 2010-04-12