

# ABB JOKAB SAFETY

## Machine Safety Systems and Components

### Compendium

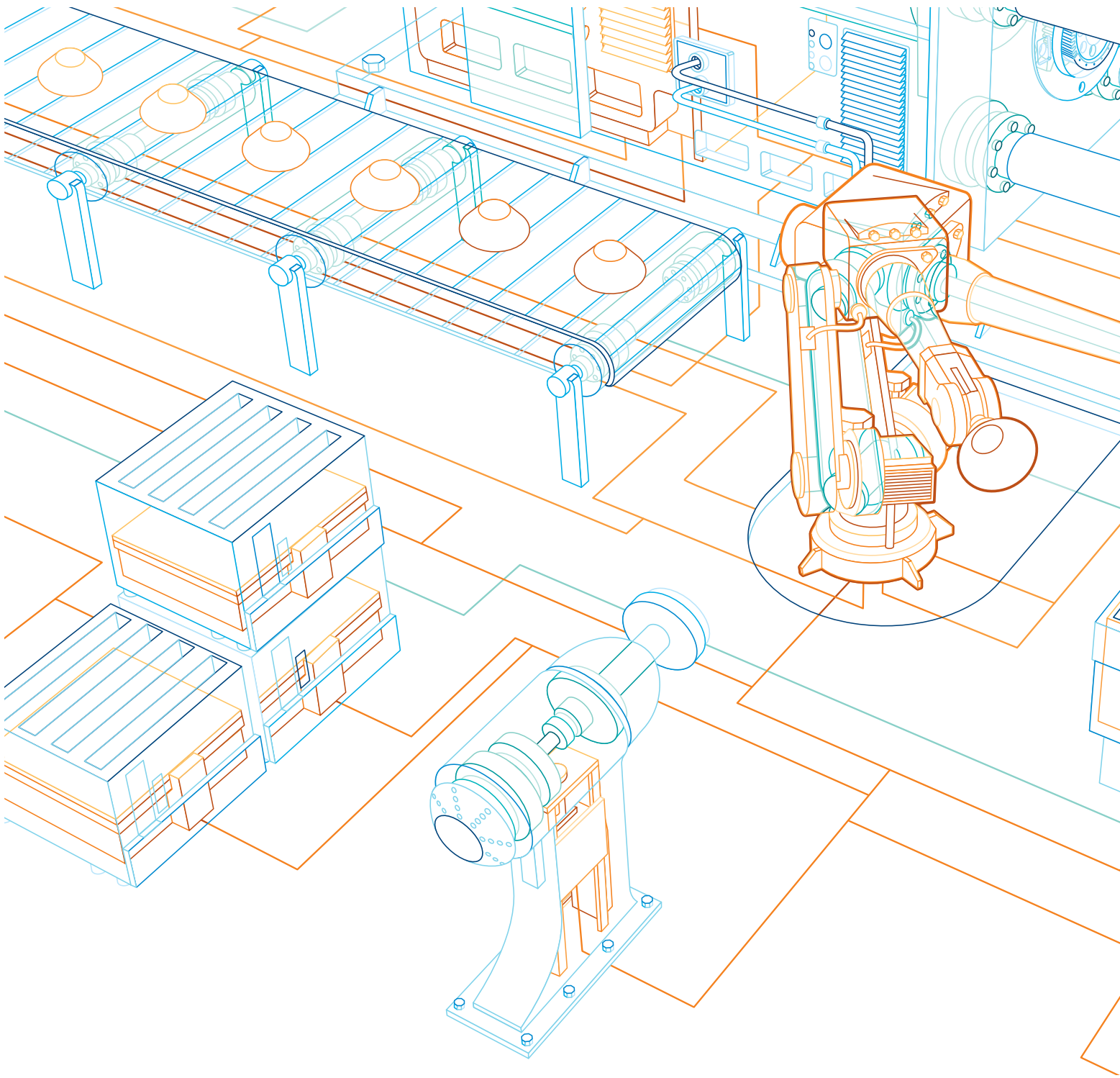

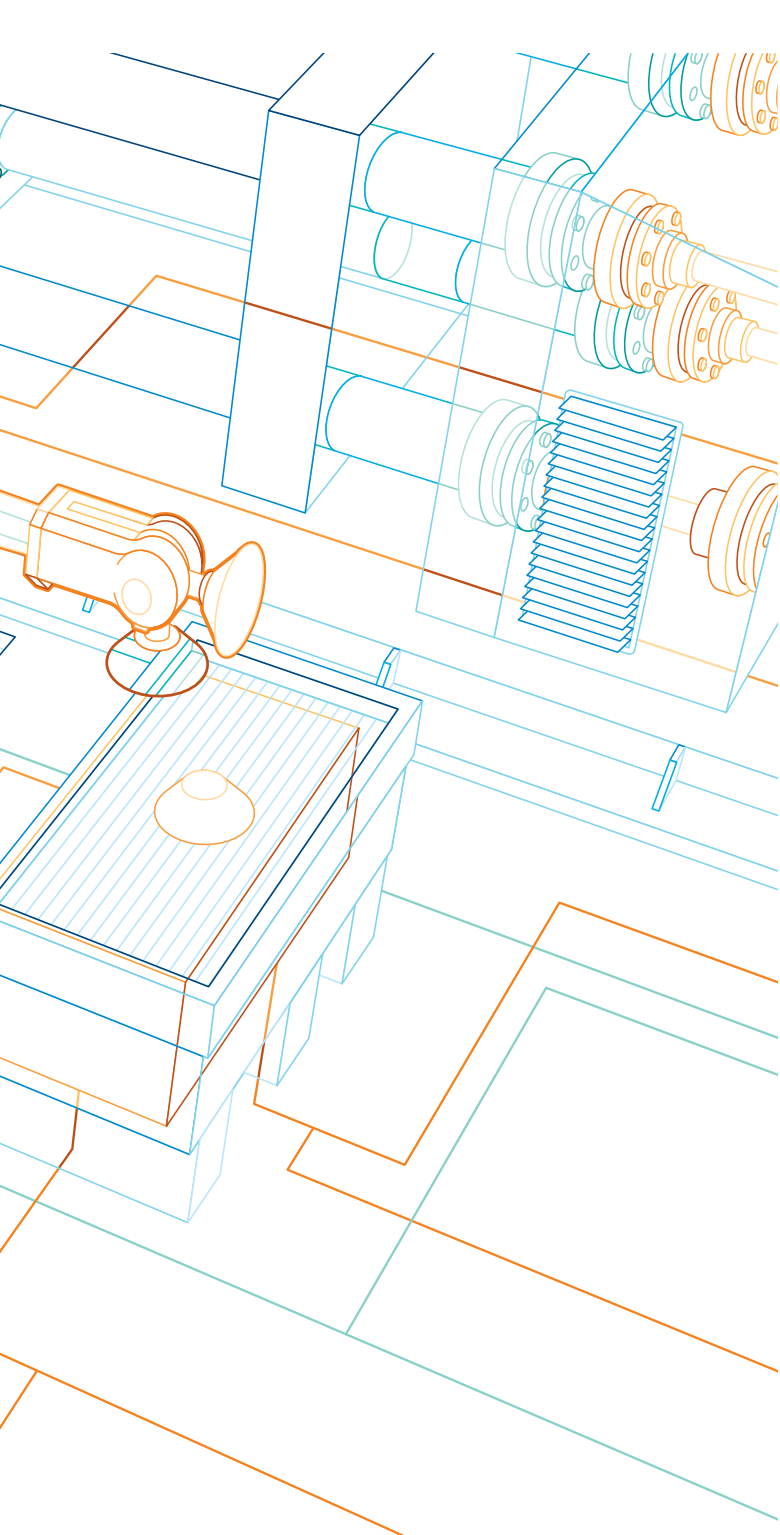

# ABB Jokab Safety Machine Safety Systems and Components Compendium

Production integrated safety solutions!  
Meeting international standards!  
Protecting the manufacturing workforce!

About ABB Jokab Safety .....	1
Pluto Safety PLC.....	2
Pluto AS-i Safety.....	3
Vital/Tina Safety Systems .....	4
Safety Relays.....	5
Focus Light Curtains and Light Grids.....	6
Stop Time Analyzers .....	7
Safety Sensors and Switches .....	8
Safety Control Devices.....	9
Emergency Stops.....	10
Contact Edges, Bumpers and Safety Mats .....	11
Quick-Guard Safety Fencing Systems.....	12
Primary Switch Mode Power Supplies CPE Range.....	13
Block Contactors .....	14
Contactors Relays.....	15
Pilot Devices.....	16
Terms and Conditions .....	17

Together, we'll create a safer, more reliable and innovative future for your business!

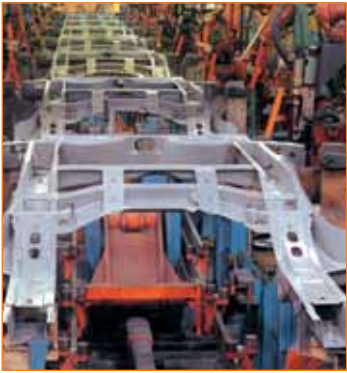



# About ABB Jokab Safety

Over two decades of experience!  
 Complete machine safety systems!  
 Unsurpassed customer support!

Productivity and Safety ..... 1:2  
 Our products revolutionize the market..... 1:4  
 Safety History ..... 1:5  
 Jokab Safety's Developments ..... 1:6



The Leader in Engineered  
 Machine Safety Systems..... 1:8  
 Specialization Provides Value ..... 1:10  
 Unsurpassed Customer Support ..... 1:12  
 A Commitment Your  
 Company Should Make..... 1:13  
 Planning Your Machine Safety Strategy..... 1:14  
 Machine Safety Consultation and  
 Comprehensive Training Seminars..... 1:15  
 Explanations of Safety Terminology..... 1:18  
 Directives and Standards ..... 1:20



Risk Assessment ..... 1:22  
 New Standards for Safety in Control Systems ..... 1:23  
 Working Method as specified in EN ISO 13849-1 ..... 1:24  
 What defines a Safety Function? ..... 1:28  
 Applying EN 62061 ..... 1:30  
 A Mechanical Switch  
 does not give a Safe Function ..... 1:31  
 Safety Standards Organizations  
 and Information Sources..... 1:32  
 Machine Safety Standards..... 1:40



# Productivity and Safety go hand in hand...

Jokab Safety was acquired by ABB in March 2010. This gives us extra strength and a sales network in 120 countries. Our goal is to become even better at supporting you as a customer through cooperation within ABB Jokab Safety globally and locally.

The fact that the leading power and automation technology company, ABB, and a leader in machine safety, Jokab Safety, are joining forces means a lot more than just a new organizational chart. ABB has a huge footprint in the industry — from power supply to the control of each individual motor — and has been delivering reliable solutions for decades that boost productivity in the industry.

The acquisition of Jokab Safety now means the last building block is in place. We can now offer our customers tailored, turnkey solutions where machine safety is an integral and value enhancing component.

Since its inception in 1988, Jokab Safety has been adhering to the business concept of developing innovative products and solutions for machine safety. The company has supplied everything from individual safety components to fully installed protection systems for entire production lines and works on a daily basis with the practical application of safety requirements in combination with production requirements. Jokab Safety is also represented on a variety of international standards committees concerned with the safety of machinery which means that we have now added this very valuable experience and knowledge to our offering. Similarly, ABB has always been a pioneer and a representative for its business areas and a powerful voice in professional organizations and committees.

All in all, this creates an enormous bank of knowledge and experience that we look forward to sharing with our customers.





*The fact that the leading power and automation technology company, ABB, and a leader in machine safety, Jokab Safety, are joining forces...*

*...creates an enormous bank of knowledge and experience that we look forward to sharing with our customers.*

**MACHINE SAFETY**

Productivity and safety are not contradictory terms. On the contrary, safety solutions that are properly executed and adapted from the beginning will increase productivity.

A partner that can deliver integrated and well thought out turn-key solutions enables a production friendly safety environment.

ABB Jokab Safety's methodology for safety upgrades to existing machinery takes into account all modes of operation. This creates a safety system that enhances rather than restricts production, thus creating "Production Integrated Safety Solutions" for our customers.

# Our products revolutionize the market!

Our dynamic safety circuits and our comprehensive safety PLC are probably the most revolutionary developments that have happened in the safety field for the control and supervision of safety devices, in many respects:

- They save on inputs: a dual safety circuit with one conductor instead of two. In addition, many protection devices can be connected to the same input while maintaining the highest level of safety.
- They are safer, since our dynamic safety sensors are checked 200 times per second. Traditional switches on a door can only be checked each time they are used, for example once per hour or even once a month.

- Reliability is better. Our electronic sensors have much longer lives than mechanical switches.
- With the All-Supervisor Safety PLC it is easy to connect and disconnect machinery from a safety viewpoint. Common emergency stop circuits and sensors can be created as soon as the buses are interconnected between our safety PLCs.

We are continuously designing safety systems for difficult environments and also to create new safety solutions where practical solutions are missing. New technical improvements give new possibilities and therefore we continuously develop new products.

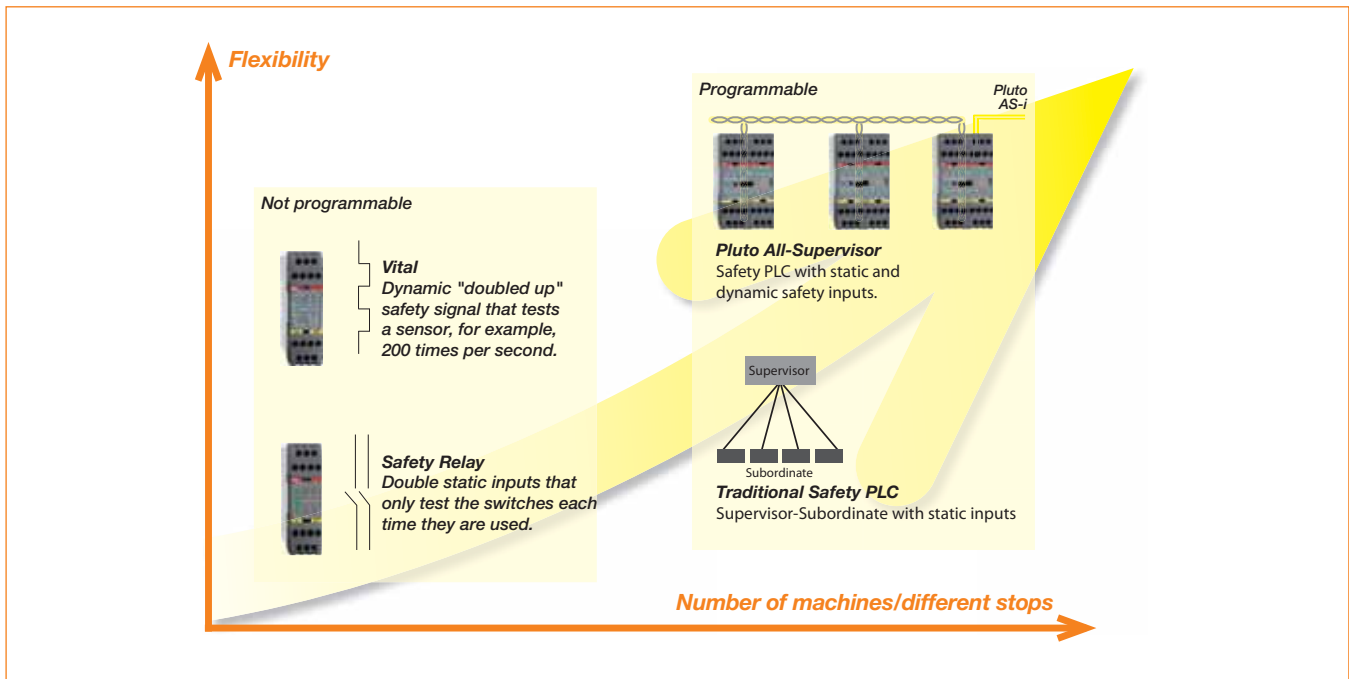

## We train both machine builders and operators

### Do you build machinery?

We can provide the training you need to build machinery that meets the requirements, including:

- Practical implementation of the requirements in the new Machinery Directive 2006/42/EC, which is valid for machines that were delivered/put into service from the 29th of December 2009
- Risk analysis—in theory and practice
- Control systems safety—standards EN ISO 13849-1 and EN 62061

### Do you purchase and use machinery?

As a machinery user it is your responsibility to ensure that the correct requirements are complied with—regardless of whether your machinery is “new” or “old”, i.e. CE-labeled or not. Unfortunately many have purchased CE-labeled machinery that does not meet the requirements.

Having machines brought into compliance by the supplier can take a long time and be expensive in terms of loss of production, etc. We can educate you on this and help you to set the right demands when buying new or even second-hand machinery.



# Safety History

## Developments of the 1970s

Our background in safety started in the seventies when there was a significant focus on the safety of manually operated presses, the most dangerous machine in those days. The probability of losing a finger or hand while working with these machines was very high. New safety solutions for both safety devices, as well as for the control systems for presses, were developed and introduced on both old and new machines. We were directly involved in this work through the design of two-hand devices, control systems for presses, making safety inspections for the Health and Safety authorities, and writing regulations for the safety of these machines. This work provided an excellent base for our knowledge in machinery safety.

The number of accidents involving presses decreased significantly during these years, however there is still room for new ideas to enable safety equipment to become more practical and ergonomic.

## Developments of the 1980s

During the eighties, industrial robots (Irb's) started to become commonplace in manufacturing industry. This meant that workers were outside of the dangerous areas during production, but had to go inside the machine at certain times in order to adjust a product to the correct position, inspect the production cycle, troubleshoot, and to program the Irb. New risks were introduced and new safety methods required.

It was, for example, hard to distinguish whether a production machine had stopped safely or was simply waiting for the next signal—such as a sensor giving a start signal—while a product was being adjusted into the correct position. Mistakes in safety system design resulting in serious accidents were made, such as the omission of safety devices to stop the Irb, unreliable connection of safety devices, and unreliable safety inputs on the Irb.

In the mid eighties the standards committee for safety in Industrial Robot Systems EN 775/ISO 775 was started. This was the first international standard for machine safety. In order to give the correct input to the standard, work around Irb's was closely studied in order to meet production integrated safety requirements. The introduction of a production oriented safety stop function was made, using for example, software to stop machines smoothly and then safety relays/contactors to disconnect the power to the machines actuators after the machine had stopped.

This technique allows easy restart of production after a stop situation by the machine safeguards. There were a lot of discussions as to whether one could have both safety and practical requirements in a standard, such as a safe stop function, which allowed an easy restart of the machine.

Three-position enabling devices were also introduced for safety during programming, testing and trouble shooting of Irb's and other equipment. In the robot standard the three-position enabling function was first defined by only allowing for hazardous machinery functions in the mid switch position. Releasing or pressing the three-position push button in panic leading to a stop signal.

## Developments of the 1990s

In Europe, during the nineties, the machinery directive was the start of a tremendous increase in cooperation across borders to get European Standards for safety for machinery and safety devices. The experience from different European countries has led to a wide range of safety standards and this has made work in safety much easier. With the integration of Europe it is now only necessary for a safety company such as ourselves to get one approval for our components for all of Europe instead of one per country.

## Developments 2000s

Internationally, the work on safety has now been intensified within ISO. The objective is to have the same structure of safety requirements and standards within ISO as within EN.

ABB Jokab Safety is active both internationally and nationally in different standard working groups. The cooperation between countries is leading to better safety solutions, making it much easier to create safe working environments around the world.

# Jokab Safety's Developments...

...of the 1980s

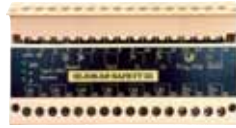

Jokab Safety's  
First Safety Relay

Jokab Safety's  
First Steel Fencing  
System

...of the 1990s



Timer Reset and First Light Beam

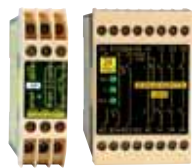

Smallest  
Safety Relays  
JSBT5 and  
JSBR4

Quick-Guard  
Aluminum  
Fencing System

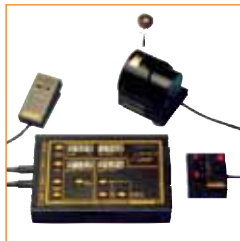

Safeball  
Ergonomic  
Control Device



Three-Position  
Switch for Robots

Stop Time  
Measurement

Three-Position  
Devices

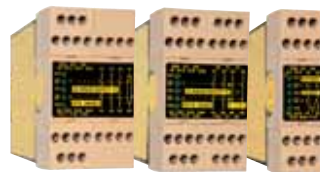
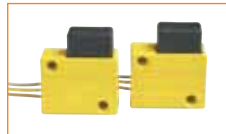

RT Series Universal Relays

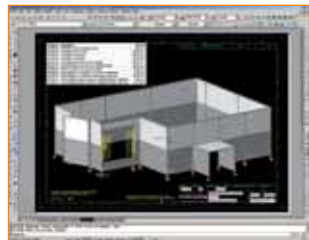

SafeCAD® for  
Quick-Guard

...of the 2000s

Vital 1 with Dynamic Safety Circuits

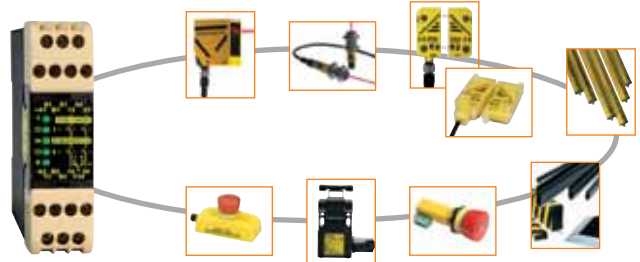

Vital 2 with Dynamic Safety Circuits

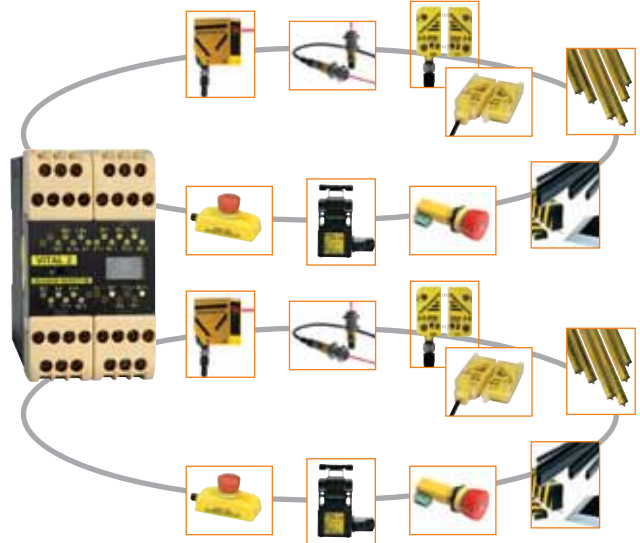

Vital 3 with Dynamic Safety Circuits

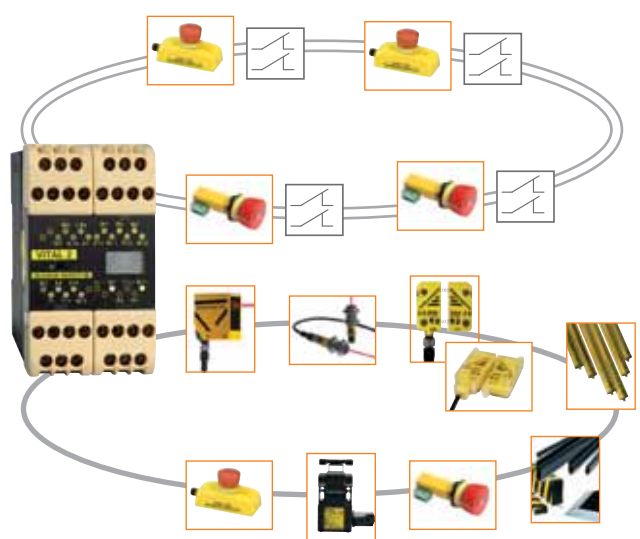

**Pluto All-Supervisor Safety PLC**

- Profibus DP
- DeviceNet
- CANopen
- Ethernet

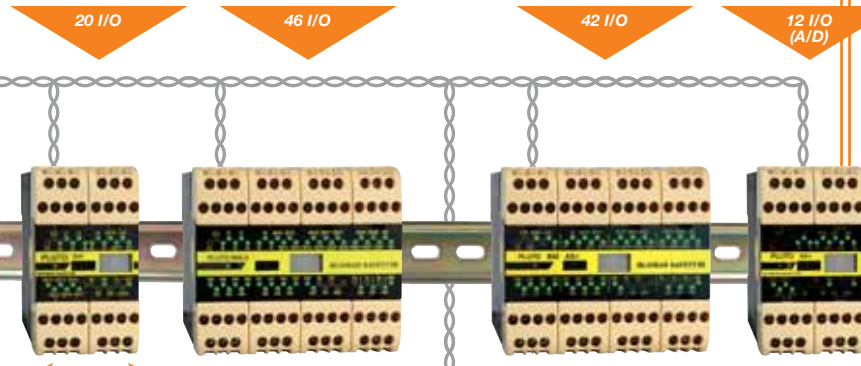

Sensors with integrated AS-i nodes



Safety Nodes for connection of sensors on the AS-i cable



**Non-Contact Sensor Eden**



E-Stops Smile and Inca



Guard Locks



Smart for Machine Diagnosis



Focus Light Beam



Three-Position Device with Hand Detection



# ABB Jokab Safety...

## The Leader in Engineered Machine Safety Systems

ABB Jokab Safety has over two decades of worldwide hands-on experience in the design, engineering, manufacturing, and application of electronic safety components, safety fencing, and complete machine safety systems. Our goal has always been the protection of the manufacturing workforce—and it has made ABB Jokab Safety the leader in the machine safety industry.

We offer complete machine safety solutions that will help protect valuable staff and meet standards and regulations relevant to your business. ABB Jokab Safety has provided safety systems to all types of manufacturing companies throughout the world. Many manufacturers, large and small, have come to rely on our expertise for training, compliance guidance, systems design and application.

### Understanding Complete Machine Safety Systems

Today's manufacturers often struggle to see beyond the current misunderstandings of the true meaning of machine safety. Their approaches are narrow in vision and focused on the components to be purchased—or some new item intended to improve only one part of a machine safety system—instead of focusing on the overall picture, the complete machine safety system as a whole.

The companies that claim to be machine safety specialists, but can only offer a limited range of so-called safety devices, perpetuate much of the confusion and misinformation about machine safety. Many of these devices were adapted from products that were designed for other applications, not machine safety.

The idea that all safety devices are the same—and can be purchased as commodity products for the lowest price, is a myth. Hundreds of companies are spending good money on the wrong components. This misplaced belief ultimately leads to higher overall costs, incorrect applications that may not comply with specified safety standards, and can result in unsafe conditions.

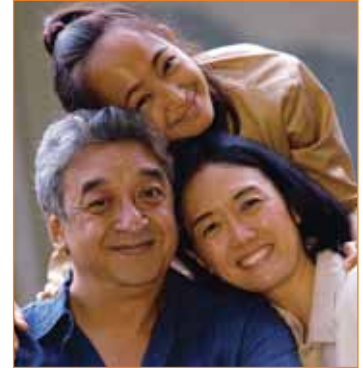

*The idea that all safety devices are the same—and can be purchased as commodity products for the lowest price—is a myth.*



ABB Jokab Safety customers have recognized that within the machine safety industry, we stand alone as the company superior to all others in its vision, design, manufacturing, and application of “Complete Machine Safety Systems”. We are a company that clearly sees the big picture and understands what it takes to compete in a world market.

Our systems can help make the difference between winning and losing. Not just competing, but also adding future profit to our customer’s bottom line with “Complete Machine Safety Systems” that offer easier installation, built-in diagnostics, and less downtime.

ABB Jokab Safety is helping manufacturers to see beyond the confusion created by those companies whose only interest is to sell “look alike” products at commodity prices. By educating our customer about the advantages of the “Complete Machine Safety Systems” approach, they soon realize that they can achieve the highest category of machine safety, while controlling overall costs.



*Together, we’ll create a safer, more reliable and innovative future for your business!*



#### ABB Jokab Safety offers...

- Over 20 years of experience helping companies increase their machine safety level, without sacrificing production.
- Ability to design and manufacture custom systems to meet your company’s requirements.
- Machine safety systems designed to protect company personnel from injury.
- Compliance to applicable national and international machine safety standards.
- Cost savings on safety system design and installation time.
- Time saved on labor with reduced wiring points.
- Unique diagnostics that save machine downtime.
- Cost effective alternative to unsafe bypassing methods.
- Consultation, engineering, design, and CAD drawings.
- Machine safety systems operational training.



*So before you purchase machine safety equipment, talk to your ABB Jokab Safety representative.*

## Specialization Provides Value

From the inception of ABB Jokab Safety, our focus has been to provide solutions for industrial manufacturing machine safety problems. We have long recognized the need for reliable, cost effective machine safety systems and will continue to specialize in machine safety for all industrial manufacturing applications.

ABB Jokab has successfully provided machine safety systems for robotic cells, automated production and assembly lines, conveyor and material handling systems, power and hydraulic press operations, welding lines, woodworking machinery, packaging equipment, food processing equipment, extruding machinery, plastic or rubber molding machines — as well as many other types of machinery.

As applications specialists and systems solutions providers, we offer comprehensive services in the form of consultation, knowledge of national and international standards, product training seminars, engineering assistance, CAD drawings, customization of products to meet customer specifications, operational training and complete after the sale follow-up services. ABB Jokab can assist customers in making the right choices to help protect employees, meet standards relevant to their industry, maintain high production levels, and control system costs.

### Design and Engineering for Complete Machine Safety Solutions

The key to a successful machine safety solution is the custom design and engineering of the safety system for each specific machine safety application. Our knowledgeable engineering staff possesses many decades of experience in providing manufacturing companies with electronic machine safety systems that have solved a multitude of workplace safety problems, while maintaining high levels of productivity.

ABB Jokab Safety engineers and technicians support our customers with the technical knowledge, CAD drawings and guidance they need to protect their employees and comply with the standards and regulations that are applicable to their manufacturing operations. Our engineers can create safety solutions for all of your current production equipment, as well as proposed future manufacturing operations.

Complete Machine Safety System planning will include guiding our customers through the identification of the hazardous areas of concern, and provide solutions that will help protect employees and meet or exceed safety standards relevant to their manufacturing processes.



*The key to a successful machine safety solution is the custom design and engineering of the safety system for each specific machine safety application.*



## Understanding National and International Safety Standards Ensures Compliance

Understanding National and International Safety Standards pertaining to the manufacturing industry can be very difficult, and keeping up with the constant changes can be nearly impossible. Fortunately, when it comes to understanding the concept of machine safety—including updates of all pertinent standards or regulations—ABB Jokab Safety offers the assistance you need.

We are not satisfied to simply bring our customers up to par with industry safeguarding regulations. We will keep

them aware of the changes that are constantly arising by providing updates on standards and knowledge of each new breakthrough in machine safety systems technology. With this in mind, we will continue to complement our product line with innovations to serve our customers' needs.

ABB Jokab Safety has a clear understanding of national and international safety standards and regulations and we are fully prepared to assist our customers in determining which standards they must meet including: ANSI (American National Standards Institute); CSA (Canadian Standards Association); EN (European Nation Standards); IEC (Electrical Equipment of Industrial Machines); NFPA (National Fire Prevention Association); ISO (International Organization for Standardization), and OSHA (Occupational Safety and Health Administration).

## Trained, Knowledgeable Safety Sales Specialists

Every ABB Jokab Safety Sales Specialist represents safe solutions for unsafe manufacturing environments that may exist in our customers' manufacturing facilities. Our highly trained and knowledgeable Safety Sales Specialists and distributors are committed to introducing the concept of "Complete Machine Safety Systems" to every manufacturer throughout the United States, Canada and Mexico. They are on the road every day meeting with customers to offer safe solutions for all types of current or future manufacturing equipment.



# Team Concept offers Unsurpassed Customer Support

Our team concept provides each customer with a team of highly trained machine safety professionals that include an experienced Safety Sales Specialist, Product Managers that are knowledgeable about the applications of each safety system and component they handle, and System Designers that possess vast technical expertise in machine safety and control reliability to ensure total satisfaction.

ABB Jokab Safety offers customers unsurpassed support with an initial consultation and guidance on what standards must be met, engineering and CAD drawings of their safety system, selection of certified electronic safety components and guard fencing, operational and maintenance training, and reliable follow-up services. There is no other company that can offer you more.

## Responsive Inside Sales Support

Our dedicated commitment to customer service is reflected by the responsive efforts of our inside sales support staff — a group of experienced individuals who ensure that each order we receive will be processed promptly and efficiently. Each member of our inside sales support staff works closely with their designated Safety Sales Specialists to provide the latest information on availability of product, price quotations and delivery times.

All members of the ABB Jokab Safety sales support staff are constantly updated to keep them current on the new components and systems that provide our customers with the highest level machine safety and control reliability. In addition, our sales support staff participates in all factory authorized training programs to keep them informed on all new product features to existing lines.



## Inventory and Shipping to Meet Your Needs

The same dedication to customer service is evident in our shipping department. Our goal is to provide our customers with the safety components and systems they require in the most cost effective, timely manner possible.

We maintain a comprehensive inventory of all the machine safety systems and components we manufacture including safety relays, safety light curtains and grids, perimeter beams, stop time analyzers, safety enabling devices, non-contact/non-magnetic sensors, one and two hand controls, magnetic and interlock switches, safety PLCs and more.

In addition, we manufacture a complete line of Quick-Guard Safety Fencing and accessories that meet any fencing application. With stocking locations in both Canada and the USA, we can handle shipping requests from standard through overnight delivery.



## Combining High Level Safety with Peak Production

If your company is like the many others who are concerned about how they can protect their workforce with the highest level of machine safety, while maintaining peak production and lowering overall machine safety system costs, contact ABB Jokab Safety today.

*ABB Jokab Safety can help  
you cut through the mountain  
of misinformation and provide  
your company with a better  
understanding of what  
machine safety means.*



# Machine Safeguarding...

## A Commitment Your Company Should Make



What is the motivation for making a commitment to safeguard the machines that are used for the production of the parts and components that your company manufactures? ABB Jokab Safety believes that the primary and most important motivation for safeguarding is to protect the sanctity of human life and limb.

Every company should realize that their human resources are their most important asset. The protection of your employees is not based on the fact that there are regulatory standards that must be met, but rather the higher standard of the ethical obligation to ensure that all of your staff leave work in the same physical condition as when they arrived.

The value of seeing that every employee has the opportunity to work in a safe environment far exceeds the economic consequences that are associated with work-related injuries. The same safety devices and systems that can reduce the severity or eliminate injuries to employees that program, operate, test or perform service maintenance to machines provide a line of defense against the financial expenses associated with each injury. In pure economic terms, there are obvious advantages to properly safeguarding your manufacturing machinery. No company wants any of their valued staff to suffer an injury, and employers do not want to deal with the financial “after effects” associated with a work-related injury.

The reason for using machine safety devices is clear, because wherever a worker has access to a hazardous area during a machine cycle, it's not if an injury will take place, but rather when the injury will take place.

### The True Cost of Work-Related Injuries

There are companies that feel that the cost of purchasing and installing the proper safety devices on all of their manufacturing machinery is too costly and may slow down production. These companies should take the time to analyze the true cost of just one work-related injury and compare that cost to the purchase and installation of the approved safety devices that could prevent that injury. The costs of a work-related injury go far beyond hospital stays and medical bills incurred to treat the injury. There are many other variable costs to be considered as shown in the following list:

- Workers Compensation Benefits
- Loss of experienced operator
- Production downtime
- Fines from Regulatory Agencies
- Training and placement of new operator
- Tarnished business and public image
- Emotional impact/drop in coworkers morale
- Probability of major lawsuit
- Increased insurance rates
- Possible damage to equipment or tooling
- Internal and External Investigation (Regulatory Agency)
- Expenditures to bring machinery into compliance
- Management time to review, resolve problems and implement changes
- Long-term physical and emotional impact on injured employee

After calculating the true costs of a work-related injury, those companies who feel that the cost of meeting their safety obligations is too high, often realize that machine safety doesn't really cost—it pays!

### Committed to Safeguarding Man and Machine

ABB Jokab Safety is committed to the design, engineering, and manufacturing of the electronic safety devices and systems that will meet or exceed all necessary safety standards or regulations and provide the highest level of machine safety possible. With over two decades of manufacturing experience, ABB Jokab Safety is recognized throughout the world for innovation and quality.

The goal of ABB Jokab Safety is to make it possible for manufacturing companies across North America to have the opportunity to protect their employees with the most reliable electronic machine safety components available in the industry.

# Planning your Machine Safety Strategy

Each company has an obligation to provide employees with the safest working environment possible. Machine safety is governed by various regulatory agencies and companies are expected to make every effort to be in compliance with the safety standards that apply to their industry.

Therefore planning a “Machine Safety Strategy” must be regarded as a major concern for all industrial manufacturing companies. “Risk Assessment” is the primary element of any Machine Safety Strategy and is a process comprised of several steps.

Documentation must be completed during every step of your Risk Assessment process. It is necessary to consider all stages in the life cycle of each machine including installation, commissioning, standard maintenance, trouble-shooting, correct use operation and decommissioning. In addition, the consequences of foreseeable misuse or malfunction must be considered. Some hazards to look for include crushing, entanglement, shearing, part ejection, radiation, fumes, toxic substances, noise levels, and extreme heat.

Risk Assessment is based on a clear understanding of each machine’s limits and functions, as well as all tasks the machine is required to perform, which in combination must be analyzed to identify hazards. The degree of risk attributed to each hazard is then estimated in order to provide a foundation for final safeguarding selection at a later stage. A validation will then be necessary to determine if the applied safety measures are sufficient or if additional measures are needed to reduce the risk. Risk Reduction is achieved when safety measures selected according to the information derived from the Risk Assessment process has brought risk to an acceptable level.

The initial steps of the Risk Assessment process are “Machine Limit Determination” and “Hazard Identification”. This consists of making a complete list of all machinery in operation on your plant floor. Where separate machines are linked together, either mechanically or by control systems, they should be listed as a single machine. Next include all possible operations and usage for each machine. Then based on the concept of “AUTO”—Around-Under-Through-Over—each machine on the list is studied by looking at the equipment from all angles to establish any type



*Photo courtesy Herman Miller Inc.*

of hazards that exist and the list is noted accordingly. The next step in your Machine Safety Strategy is “Risk Estimation”. All manufacturing machines contain hazards that represent varying degrees of risk. It is necessary to be able to describe at what level each risk lies on a minimum to maximum scale. When conducting Risk Estimation you must consider the severity of potential injury, the frequency of exposure to the hazard and the possibility of avoiding the hazard.

A “Validation” is required to determine if the existing safety measures are satisfactory or if additional measures are necessary to reduce the risk. “Risk Reduction” is then performed and the necessary safety measures are selected based on the information documented from the prior steps of the Risk Assessment process.

To further help you and your company understand the Risk Assessment and Risk Reduction process, we offer a selection of Production Integrated Machine Safety Training Seminars that include a session entitled Risk Assessment and Risk Reduction. The training includes reviewing the various types of risk assessments. Discussion will cover how to set up a risk assessment team, the process involved in new equipment buy-offs, who should review equipment modifications and the process of ensuring on-going compliance to the relevant standards and codes.

# Machine Safety Consultation and Comprehensive Training Seminars

## Machine Safety Requirements that Govern Your Industry

Do you know what machine safety requirements govern your specific industry today? With the constant changes in standards and requirements, how does your company keep up with them?

Machine Safety and Control Reliability are more important than ever before, and every day National and International Standards are becoming increasingly more complicated. As a business, machine designer and manufacturer, your company is obligated to know about—and to follow—all machine safety standards and regulations. Compliance to the regulations and standards that govern your industry is not only necessary to make your employees safe, but also to make your company defensible if an accident should occur. Nevertheless, we understand that it can be difficult for each individual company to keep track of all the new regulations and how they should be applied.

## ABB Jokab Safety Can Help Your Company Understand

Your local ABB Jokab Safety representative can provide your company with machine safety consultation, training and analysis during all stages of the design, build and complete installation of machinery—or as an ongoing consulting assignment with periodic meetings throughout the year.

We can help your management team and employees understand how these machine safety standards affect your company today with comprehensive training seminars conducted either at our facilities—or at any site of your choosing.

ABB Jokab Safety course trainers offer decades of experience in machine safety and control reliability, as well as extensive knowledge of machine safety regulations and standards.

*Call us at 1-888-282-2123 today to arrange for your company's Consultation or Training—and get on the right track toward total compliance.*



## Meeting North American and European Machine Safety Standards

A distinguishing feature of all the ABB Jokab Safety engineers is that they work daily with practical applications of standards and regulations. This is true for everything from safety components for individual machines, to the design and creation of entire machine safety systems for larger manufacturing production lines. We also participate in standardization groups which decide on North American and International Standards concerning machine safety. Because ABB Jokab Safety has global representation, we have up-to-date knowledge of the machine safety requirements in many different countries.

## Machine Safety Solutions—the time is now!

The need for machine safety has become one of the most important concerns for manufacturers today. The necessity to protect employees from injury, to meet governing machine safety standards, and to have documentation to make your company defensible are realities that cannot be ignored.

The questions that most companies ask are either “How do we get started?” or “How do we keep our current machine safety systems compliant with the changing standards?” The answer to these questions are the same—contact ABB Jokab Safety and schedule a Machine Safety Consultation with one of our Safety Products Specialists.

# Current ABB Jokab Safety Seminars

## MACHINE SAFETY SEMINARS

- Understanding Control Reliability
- Understanding General Machine Guarding
- Planning Your Machine Safety Strategy and Making Your Company Defendable
- Risk Assessment and Risk Reduction

## INDUSTRY SPECIFIC SEMINARS

- RIA Robotic Machine Safety Standards
- Package Machine Safety Standards
- Printing Press Safety Standards
- Custom Training Packages to Meet Customer Specific Needs

## PRODUCT SPECIFIC SEMINARS

- Pluto Manager Software for Pluto Safety PLC Programming
- Presence Sensing Device Selection and Installation with Safe Distance Calculation Fundamentals
- Smart Stop Time Analyzer and Smart Manager Real-Time Control Software
- SafeCAD® Fencing Design Software

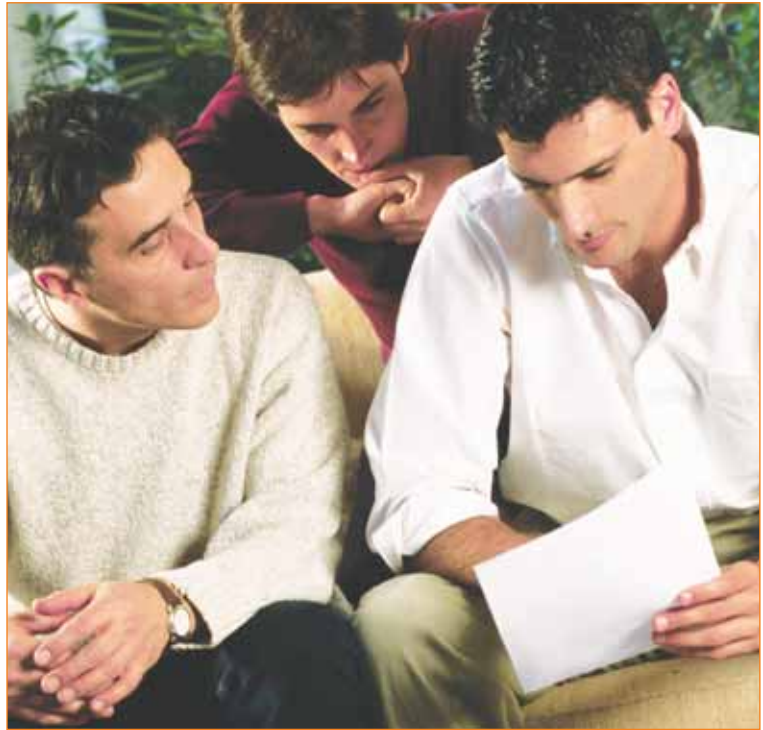

## MACHINE SAFETY SEMINARS

### Understanding Control Reliability

This seminar will cover the subject of Control Reliability and its' definition as it pertains to National and International Machine Safety Standards. References are made to various sections of the European Standard EN954 and ANSI B11.19. The importance of having control reliable circuits and protective elements will be discussed in detail.

### Understanding General Machine Guarding

Training will detail the proper method for hazard identification and choosing the right machine safeguarding element for each application. Coverage of various sections relative to machine safety standards — such as ANSI B11.19 and CSA Z432-04 — are reviewed. Limitations and appropriate methods of installing light curtains, laser scanners, safety mats, relays, and other devices, are discussed. The CFR Part 1910 Occupational Safety and Health Standards for General Industry - Subpart O Machinery and Machine Guarding will be reviewed as appropriate. The concept of “AUTO”—Around–Under–Through–Over, when designing and installing machine safeguarding, shall be discussed.

### Planning Your Machine Safety Strategy and Making Your Company Defendable

Each company has the obligation to provide employees with the safest working environment possible. Machine Safety is governed by various regulatory agencies, and companies are expected to make every effort to be compliant with these safety standards. This seminar is a guideline about “Planning Your Machine Safety Strategy,” and why it must be regarded as a major concern if part of your goal is “Making Your Company Defendable.” Discussions about Risk Assessment, Machine Limit Determination, Stopping Time and Distance, Hazard Identification, Documentation, and Validation are included.

### Risk Assessment and Risk Reduction

Training includes reviewing the various types of risk assessments such as the RIA 15:06, as well as ANSI B11.3 Risk Assessment and Risk Reduction, A Guide to Estimate, Evaluate and Reduce Risks Associated with Machine Tools. Discussion will cover how to set up a risk assessment team, the process involved in new equipment buy offs, who should review equipment modifications, and the process of ensuring on-going compliance to the relevant standards and codes.

## INDUSTRY SPECIFIC SEMINARS

### RIA Robotic Machine Safety Standards

This seminar covers the latest RIA 15:06 Robot Standard. Training will include reviewing all clauses and the application of protective elements to the robot and robotic system. Discussion and review will be conducted in detail relative to the prescribed method of machine safeguarding, as well as the comprehensive risk assessment, identification of necessary tasks, solutions to reduce risk, validate proposed solutions, and documentation.

### Packaging Machine Safety Standards

Seminar presents an overview of the latest ANSI B155.1 Safety Requirements for Packaging Machinery and Packaging-Related Converting Machinery. The requirements of this standard apply to new, modified or rebuilt industrial and commercial machinery, which perform packaging functions for primary, secondary, and tertiary packaging. This standard describes the procedures for identifying hazards, risk assessments, and reducing risks to an acceptable level over the life cycle of the packaging machinery.

### Printing Press Machine Safety Standards

Training will explain sections of the latest ANSI B65.1 Graphic Technology Safety Standard - Printing Press Systems, as they pertain to machine safety. This standard applies to printing press systems, including auxiliary equipment and finishing machines, in which all the machine actuators (e.g. drives) of the equipment in the system are controlled, by the same control system. The standard provides safety requirements for the design, construction, and use of printing press systems. It addresses recognized hazards specific to printing press systems in the following areas—mechanical, electrical, slipping, tripping, falling, ergonomics, noise, radiation, explosion, fire, temperature, impact.

### Custom Training Packages to Meet Customer Specific Needs

ABB Jokab Safety can develop training seminars tailored to meet your specific needs. Whether your company is just starting to approach machine safety or considering an upgrade of current safety systems, we are prepared to assist you. If your company is searching for answers to questions—and training to help you achieve compliance to safety standards that govern your industry—our safety professionals can provide the safety solutions you require.

## PRODUCT SPECIFIC SEMINARS

### Pluto Manager Software for Pluto Safety PLC Programming

Learn how to use the exclusive Pluto Manager Software to configure inputs and outputs depending what they are connected to—static or dynamic signals. Programming is performed using ladder or Boolean algebra with timers, auxiliary memory, registers, sequential programming, and TUV-approved function blocks. The program is available to customers using one or more Pluto Safety PLCs. Programs can be loaded via one Pluto to all other Pluto controllers located on the same databus.

### Presence Sensing Device Selection/Installation with Safe Distance Calculation Fundamentals

Guidelines on how to select and install the proper Presence Sensing Device for your machine safety application is based on type of machine, process, location, distance, and level of protection needed. Know when it is appropriate to use light curtains/grids, light beams or scanners and the proper installation of each. Learn the fundamentals of calculating safe distance according to EN 999 Machine Safety Standard and others.

### Smart Stopping Time Analyzer and Smart Manager Real Time Control Software

Gain understanding of how the Smart Stopping Time and Machine Diagnosis Tool, combined with the Smart Manager Program, can provide graphic presentation of parameters for machine safety design. Applications include stopping time, stopping distance, machine speed, position of stopping signal, as well as machine maintenance and trouble-shooting. Learn how Smart is controlled in real-time by a computer using the Smart Manager Program. Discussion of how Smart can provide measurements for safe installation of safety devices and meet governing standards including EN 999 is part of this seminar.

### SafeCAD® Fencing Design Software

Learn how the SafeCAD Fencing Design Software—using Quick-Guard® safety fencing components—can create complete custom fencing designs quickly and easily. This plug-in program for AutoCAD® 2000, 2002, 2004, 2005, 2006, 2008 and 2012 can use a simple sketch of the proposed fencing system as input. Position of doors and hatches, choice of mesh, polycarbonate, aluminum, steel sheet or noise reduction infill panels, is typed in. The program automatically generates 3-D drawings along with component and cutting lists. These drawings are also used as the basis for assembly and erection of the fencing system.

# Explanations of Safety Terminology

## Supervised Reset

The input must both be closed and opened before the outputs of the safety controller are activated. Using this method both the reset device and the interconnecting cable are supervised.

---

## Test

The input is used to supervise contactors and valves, and must be closed before the safety function can be reset. It can also be used as a simple form of reset only requiring a contact closure. In this case however, the risk of short circuit must be prevented and the reset device supervised separately.

---

## Time Reset

This is used to prevent unintentional reset when somebody is in the risk area. Within a guaranteed maximum time two or more reset push buttons must be activated. The PBs must be placed in such physical positions so that the users can overview the total danger area. The Time Reset function can be achieved using a JSHT1 in combination with a safety relay incorporating a supervised reset, or with a Pluto Safety PLC.

---

## Delayed Safety Stop

Where it is permissible to allow a machine to stop before disconnection of power, it is necessary to achieve a Delayed Safety Stop. The delay period being the time between the initiation of the stop signal and the opening of the safety contacts. The time delay must be designed in such a way that it will not increase in time in the case of a component failure. This type of delay is permitted, dependent upon risk assessment, for both emergency stops and other safety devices.

---

## Bypass Connection

This is sometimes permissible where it is required to, e.g. allow material transport into a dangerous area. The Bypass Connection must be of the same safety level as the safety device being bypassed.

---

## Time Bypass Connection

This is the provision of a guaranteed maximum time for the transportation of material or passing with an enabling device.

---

## Inching

Inching requires safety outputs to be closed for a maximum period of time allowing the machine to move only a short distance each time the inching control is activated. The time must be designed so that the specified time will not increase in the case of component failure.

---

## Three-Position Enabling/Hold-to-Run Device

These devices are used during troubleshooting or testing of machines. If the device push button is pressed into its bottom position or released completely, a safe duplicated stop signal is given. ABB Jokab Safety's Three-Position Devices have duplicated switches and are supervised by a true two input channel safety controller.

**Contact Strip/Mat**

Contact Strips/Mats can be supervised by a true two input channel safety controller. A stop signal being generated when both inputs are connected (short circuited) to each other.

---

**Brake**

When a Brake Strip is squeezed a stop signal is generated when both inputs are connected (short circuited) to each other via a suitable safety relay.

---

**Two-Hand Control**

This requires the use of a safety controller to supervise that the two start push buttons are pressed within 0.5 seconds of each other before a start signal is allowed. The highest safety level requires two contacts in each PB, a duplicated stop function being given even if only one PB is released (see JSBR4). Short circuits between connecting wires are detected automatically. In the lower safety level other safety relays can be used.

---

**Interlocked Hatch**

When an Interlocked Hatch is opened an interlock device gives a stop signal via a safety controller. If the hatch cannot be entered by a human body automatic reset can be allowed.

---

**Interlocked Gate**

When an Interlocked Gate is opened an interlock device gives a stop signal via a safety controller. If the gate can be passed by a human body a safety device with a supervised reset should be used.

---

**Foot Pedal**

Safety controllers can be used to supervise Foot Pedals to ensure correct operation and to ensure short circuits in connecting cables do not cause unintentional start signals.

---

**Emergency Stop**

When an Emergency Stop push button is activated a stop signal is given via a safety controller. Reset of the Emergency Stop device should not by itself lead to a start signal being given.

---

**Machine I/O**

All types of machines have a need to interface to emergency stops, contactors and other types of safety devices. Approved safety controllers make this easy to perform.

---

**True Two Channel**

True Two Channel requires two inputs with different voltages to be closed before the safety function can be activated. A stop signal is given even if only one input is opened or a short circuit is detected across the inputs.

---

# Directives and Standards

Directives and standards are of great importance for manufacturers of machines and safety components. EU Directives giving requirements for the minimum level of health and safety are mandatory for manufacturers to fulfill. In every member country the Directives are implemented in each countries legislation. Machines which have been put on the market since December 29, 2009, must comply with the new Machinery Directive 2006/42/EC. Before that, the old Machinery Directive 98/37/EC was valid.

The objectives of the new Machinery Directive, 2006/42/EC, are to maintain, increase and equalize the safety level of machines within the members of the European Community. Based on this, the free movement of machines/products between the countries in this market can be achieved. The Machinery Directive is developed according to “The New Approach” which is based on the following principles:

- The directives give the basic health and safety requirements, which are mandatory.
- Detailed solutions and technical specifications are found in harmonized standards.

- Standards are voluntary to apply, but products designed according to the harmonized standards will fulfill the basic safety requirements in the Machinery Directive.

## Harmonized Standards

Harmonized standards give support on how to fulfill the requirements of the Machinery Directive. The diagram below illustrates the relationship between the Machinery Directive and the harmonized standards.

Within ISO (The International Organization for Standardization) work is also going on in order to harmonize the safety standards globally in parallel with the European standardization work. One consequence of this is that many existing EN-standards will, when revised, change number. For example, EN 954-1 will when revised change number to EN ISO 13849-1. Due to the New Machinery Directive, all harmonized standards will be reviewed and revised to some extent.

ABB Jokab Safety takes an active part in the working groups both for the ISO and EN standards.

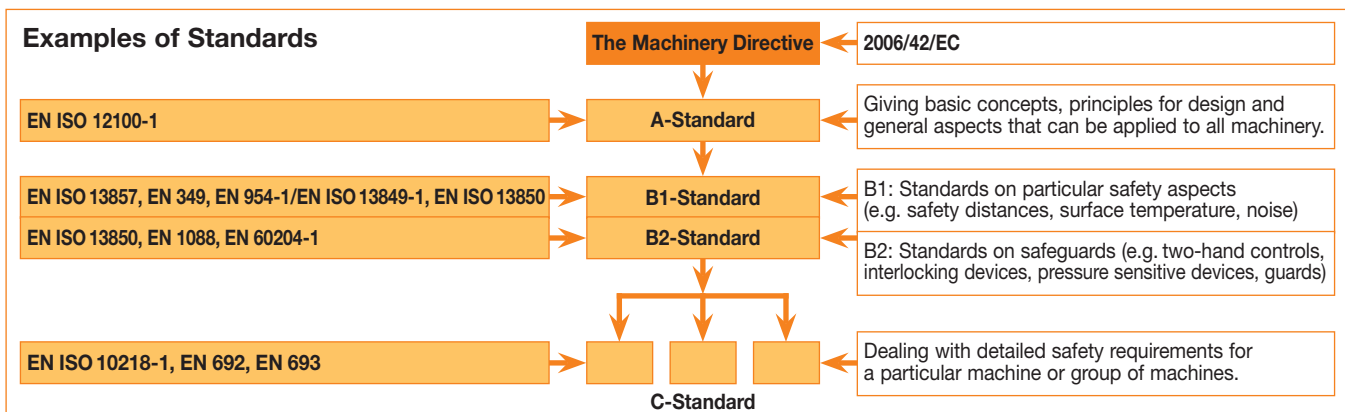

## The Machinery Directive for Machines and Safety Components

From 2006/42/EC

1 § This Directive applies to the following products:

- a) machinery;
- b) interchangeable equipment;
- c) safety components;
- d) lifting accessories;
- e) chains, ropes and webbing;
- f) removable mechanical transmission devices;
- g) partly completed machinery.

The Machinery Directive gives the following definition:

- a) machinery' means:
  - an assembly, fitted with or intended to be fitted with a drive system other than directly applied human or animal effort, consisting of linked parts or components, at least one of which moves, and which are joined together for a specific application,

— an assembly referred to in the first indent, missing only the components to connect it on site or to sources of energy and motion,

— an assembly referred to in the first and second indents, ready to be installed and able to function as it stands only if mounted on a means of transport, or installed in a building or a structure,

— assemblies of machinery referred to in the first, second and third indents or partly completed machinery referred to in point (g) which, in order to achieve the same end, are arranged and controlled so that they function as an integral whole,

— an assembly of linked parts or components, at least one of which moves and which are joined together, intended for lifting loads and whose only power source is directly applied human effort;



# CE-Marking and Declaration of Conformity

Machines manufactured or put on the market from December 29, 2009, shall be CE-marked and fulfill the requirements according to the European

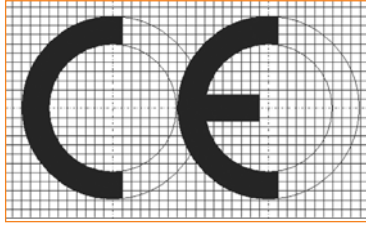

Machinery Directive 2006/42/EC. This is also valid for old machines (manufactured before 1 January 1995) if they are manufactured in a country outside the EEA and imported to be used in a country in the EEA.

For machines manufactured and/or released to the market between January 1, 1995, and December 28, 2009, the old Machinery Directive (98/37/EC) is valid.

*Note: The point in time when the Machinery Directive was implemented in each Member Country varies. Machines have to be accompanied by a Declaration of Conformity (according to 2006/42/EC, Annex II 1.A) that states which directive and standards the machine fulfills. It also shows if the product has gone through EC Type Examination.*

*Safety components have to be accompanied with a Declaration of Conformity*

## Requirements for the Use of Machinery

For a machine to be safe it is not enough that the manufacturer has been fulfilling all valid/necessary requirements. The user of the machine also has requirements to fulfill. For the use of machinery there is a Directive, 89/655/EEC (with amendment 96/63/EC and 2001/45/EC).

**About CE-marked machinery, the Directive gives the following requirement from 89/655/EEC (with amendment 96/63/EC and 2001/45/EC)**

**1 Without prejudice to Article 3, the employer must obtain and/or use:**

(a) work equipment which, if provided to workers in the undertaking and/or establishment for the first time after December 31, 1992, complies with:

- (i) the provisions of any relevant Community directive which is applicable;
- (ii) the minimum requirements laid down in Annex I, to the extent that no other Community directive is applicable or is so only partially;

This means that when repair/changes are made on the machine it should still fulfill the requirements of the Machinery Directive. This does not have to mean that a new CE-marking is required, but it can be required if the changes are extensive.

*Note: This means that the buyer of a machine also has to make sure that a new machine fulfills the requirements in the directives. If the machine does not fulfill the requirements the buyer is not allowed to use it.*

## “Old” machines

**For machines delivered or manufactured in the EEA before January 1, 1995 the following is valid.**

- (b) work equipment which, if already provided to workers in the undertaking and/or establishment by December 31, 1992, complies with the minimum requirements laid down in Annex I no later than four years after that date.
- (c) without prejudice to point (a) (i), and notwithstanding point (a) (ii) and point (b), specific work equipment subject to the requirements of point 3 of Annex I, which, if already provided to workers in the undertaking and/or establishment by 5 December 1998, complies with the minimum requirements laid down in Annex I, no later than four years after that date.

Annex I contains minimum requirements for health and safety. There can also be additional national specific requirements for certain machines. The point in time when the Machinery Directive was implemented in each Member Country varies. Therefore it is necessary to check with the national authorities in one's own country, to find out what is considered as “old” and respectively “new” machines.

## “Old” Machines

Machine that is put on the market or put into service before 1995 in the EEA.

Council Directive 89/655/EEC (with amendment 96/63/EC and 2001/45/EC) concerning the minimum safety and health requirements for the use of work equipment by workers at work.

Possible national legislation on specific machines

## “New” Machines

1. Machine that is put on the market or put into service after 1/1/95 in the EEA.
2. All machines that are imported to the EEA irrespective of date of origin.

Council Directive 89/655/EEC (with amendment 96/63/EC and 2001/45/EC) concerning the minimum safety and health requirements for the use of work equipment by workers at work. N.B! Not Annex 1, instead use applicable directives.

CE-marking + Declaration of Conformity

Machinery Directive 98/37/EC (1/1/95 -12/28/09)  
Machinery Directive 98/37/EC (from 12/29/09)

Low Voltage Directive 2006/95/EC

EMC-Directive 2004/108/EC

Possibly more directives

# Risk Assessment: Important when Assessing Risks on Older Machines or Constructing a New Machine

A well thought-out risk assessment supports both manufacturers and users of machines to develop production friendly safety solutions. One result of this is

that the safety components will not be a hindrance. This minimizes the risk of the safety system being defeated.

## New Machines

*This requirement is given by the Machinery Directive*

*The manufacturer of machinery or his authorized representative must ensure that a risk assessment is carried out in order to determine the health and safety requirements which apply to the machinery. The machinery must then be designed and constructed taking into account the results of the risk assessment.*

The standard EN ISO 12100 gives guidance on the information required to allow risk assessment to be carried out. The standard does not point out a specific method to be used. It is the responsibility of the manufacturer to select a suitable method.

## Machines in Use

**Risk assessment must be carried out on all machines that are in use; CE-marked as well as not CE-marked:**

*To fulfill the requirements from Directive 89/655/EEC (concerning the minimum safety and health requirements for the use of work equipment by workers at work) risk assessment has to be made.*

## Documentation of Risk Assessment

The risk assessment should be documented. In the assessment the actual risks should be analyzed as well as the level of seriousness.

## Protection or Warning?

How is it possible to choose safety measures that are production friendly and in every way well balanced? The Machinery Directive gives an order of priority for the choice of appropriate methods to remove the risks. Here it is further developed in a 5-step method.

The further from middle of the circle, the greater the responsibility for the safety is put onto the user of the machine. If full protection is not effectively achieved in one step, one has to go to the next step and find complementary measures.

What is possible is dependent on the need for accessibility, the seriousness of the risk, appropriate safety measures etc.

## 5-Step Method to Prioritize Safety Measures

1. Eliminate or reduce risks by design and construction.
2. Move the work tasks outside risk area.
3. Use guards and safety devices.
4. Develop safe working routines, information, education
5. Use warnings as pictograms, light, sound, etc.

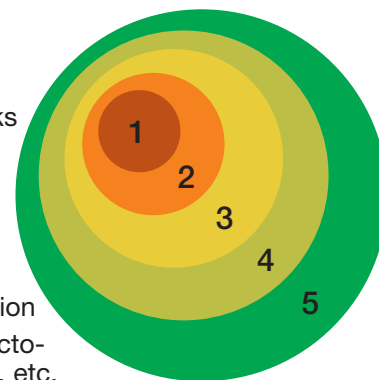

## Example of Prioritizing according to the 5-Step Method

Priority	Hazard	Safety Measure
1. Eliminate or reduce risks by design and construction	Cuts and wounds from sharp edges and corners on machinery	Round off sharp edges and corners.
2. Move the work tasks outside the risk area	Crushing of fingers from machine movements during inspection of the production inside the risk area	Install a camera.
3. Use guards and safety devices	Crushing injuries because of unintended start during loading of work pieces in a mechanical press	Install a light curtain to detect operator and provide safe stop of the machinery.
4. Develop safe working routines, information, education	Crushing injuries because the machine can tip during installation and normal use	Make instructions on how the machine is to be installed to avoid the risks. This can include requirements on the type of fastening, ground, screw retention, etc.
5. Use warnings as pictograms, light, sound, etc.	Burns because of hot surfaces in reach	Post warning signs.

The possibilities will increase to achieve a well planned safety system if each risk is handled according to the described prioritizing. The 5-step method, combined with production friendly thinking, can give you: fast and easy restart of machines after a stop from a safety device; enough space to safely program a robot;

areas outside the risk area to observe the production; electrically interlocked doors, instead of guards attached with screws, to be able to take the necessary measures for removing production disturbances; and a safety system that is practical for all types of work tasks, even when removing production disturbances.

# New Standards for Safety in Control Systems

Building a protection system that works in practice and provides sufficient safety requires expertise in several areas. The design of the safety functions in the protection system, in order to ensure they provide sufficient reliability, is a key ingredient.

## Introducing the New Standard

The generation change for standards on safety in control systems involves new concepts and calculations for machine builders and machine users. The EN 954-1 standard (categories) is being phased out and replaced by EN ISO 13849-1 (PL, Performance Level) and EN 62061 (SIL, Safety Integrity Level).

Although the deadline for using EN 954-1 is set to December 31, 2011, it is beneficial to start applying the new standards as soon as possible as many new standards no longer refer to EN 954-1.

## PL or SIL? What should I use?

The standard you should use depends on the choice of technology, experience and customer requirements.

### Choice of Technology

- PL (Performance Level) is a technology-neutral concept that can be used for electrical, mechanical, pneumatic and hydraulic safety solutions.
- SIL (Safety Integrity Level) can, however, only be used for electrical, electronic or programmable safety solutions.

### Experience

EN ISO 13849-1 uses categories from EN 954-1 for defining the system structure, and therefore the step to the new calculations is not so great if you have previous experience of the categories. EN 62061 defines the structures slightly differently.

### Customer Requirements

If the customer comes from an industry that is accustomed to using SIL (e.g. the process industry), requirements can also include safety functions for machine safety being SIL rated.

We notice that most of our customers prefer PL, as it is technology-neutral and they can use their previous knowledge in the categories. In this document, we show some examples of how to build safety solutions in accordance with EN ISO 13849-1 and calculate the reliability of the safety functions to be used for a particular machine. The examples in this document are simplified in order to provide an understanding of the principles. The values used in the examples can change.

As help for this there is, for example, the EN ISO 13849-1 standard. The purpose of this text is to provide an introduction to the standard and its application in conjunction with our products.

## What is PL (Performance Level)?

PL is a measure of the reliability of a safety function. PL is divided into five levels (a-e). PL e gives the best reliability and is equivalent to that required at the highest level of risk.

To calculate which level the PL system achieves you need to know the following:

- The system's structure (categories B, 1-4)
- The Mean Time To dangerous Failure of the component ( $MTTF_d$ )
- The system's Diagnostic Coverage (DC)

You will also need to:

- Protect the system against a failure that knocks out both channels (CCF)
- Protect the system from systematic errors built into the design
- Follow certain rules to ensure software can be developed and validated in the right way

The five PL-levels (a-e) correspond to certain ranges of  $PFH_d$ -values (probability of dangerous failure per hour). These indicate how likely it is that a dangerous failure could occur over a period of one hour. In the calculation, it is beneficial to use  $PFH_d$ -values directly as the PL is a simplification that does not provide equally accurate results.

## What is the easiest way of complying with the standard?

### 1. Use pre-calculated components.

As far as it is possible, use the components with pre-calculated PL and  $PFH_d$ -values. You then minimize the number of calculations to be performed. All ABB Jokab Safety products have pre-calculated  $PFH_d$ -values.

### 2. Use the calculation tool.

With the freeware application SISTEMA, you avoid making calculations by hand. You also get help to structure your safety solutions and provide the necessary documentation.

### 3. Use Pluto or Vital

Use the Pluto safety PLC or Vital safety controller. Not only is it easier to make calculations, but above all it is easier to ensure a higher level of safety.

# Working Method, as specified in EN ISO 13849-1

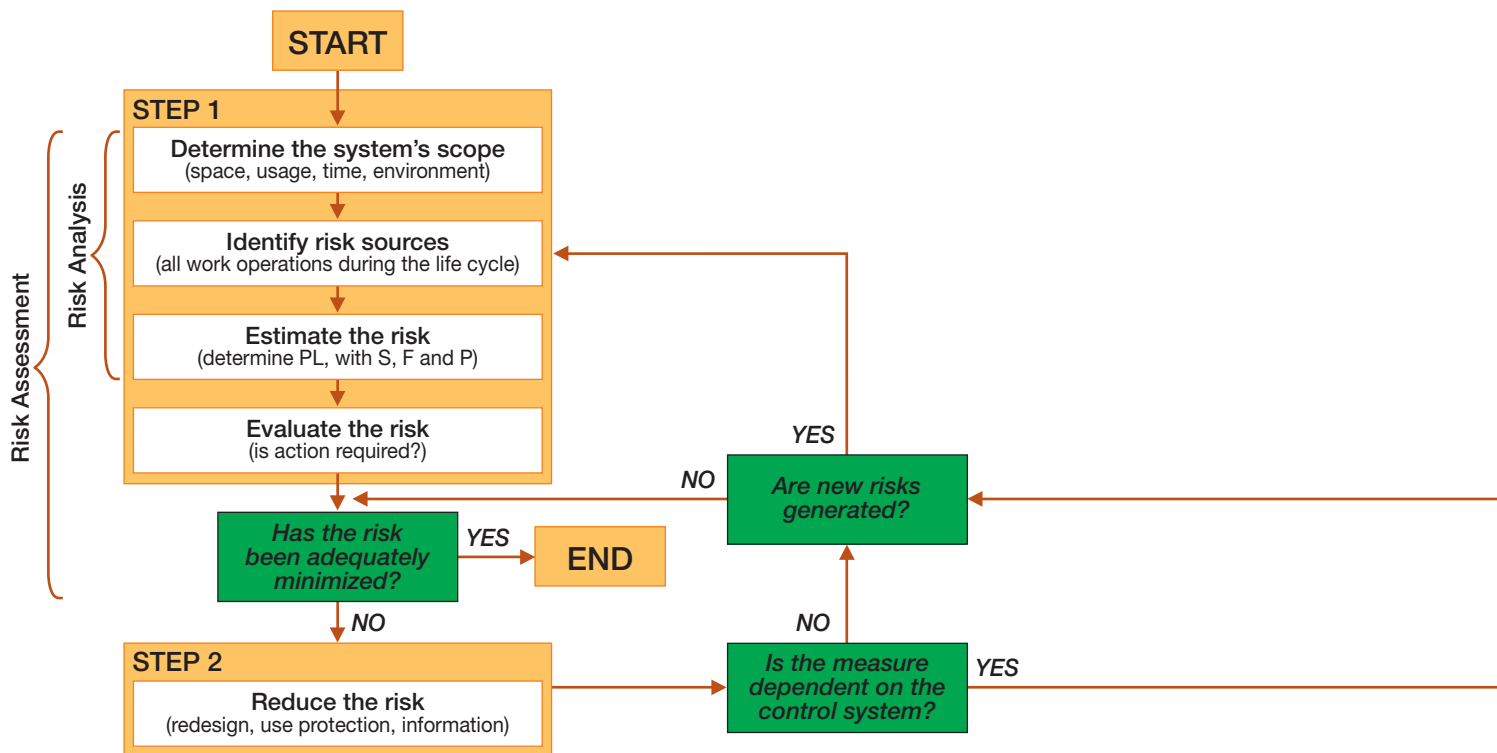

## Risk Assessment and Risk Minimization

According to the Machinery Directive, the machine builder (anyone who builds or modifies a machine) is required to perform a risk assessment for the machine design and also include an assessment of all the work operations that need to be performed. The EN ISO 12100 standard (combination of EN ISO 14121-1 and EN ISO 12100-1/-2) stipulates the requirements for the risk assessment of a machine.

It is this that EN ISO 13849-1 is based on—and a completed risk assessment is a prerequisite for being able to work with the standard.

### Step 1 – Risk Assessment

A risk assessment begins with determining the scope of the machine. This includes the space that the machine and its operators need for all of its intended applications, and all operational stages throughout the machine's life cycle.

All risk sources must then be identified for all work operations throughout the machine's life cycle.

A risk estimation is made for each risk source, i.e. indication of the degree of risk. According to EN ISO 13849-1 the risk is estimated using three factors: injury severity (S - severity), frequency of exposure to the risk (F - frequency) and the possibility you have of avoiding or limiting the injury (P - possibility).

For each factor two options are given. Where the boundary between the two options lies is not specified in the standard, but the following are common interpretations:

- S1** bruises, abrasions, puncture wounds and minor crushing injuries
- S2** skeletal injuries, amputations and death
- F1** less frequently than every two weeks
- F2** more often than every two weeks
- P1** slow machine movements, plenty of space, low power
- P2** quick machine movements, crowded, high power

By setting S, F and P for the risk, you will get the PL<sub>r</sub>, Performance Level (required) that is necessary for the risk source.

Finally, the risk assessment includes a risk evaluation where you determine if the risk needs to be reduced or if sufficient safety is ensured.

## Risk Estimation

To calculate the performance level required ( $PL_r$ )

- S** Severity of injury
  - S1 slight (usually temporary injury)
  - S2 severe (usually permanent injury or death)
- F** Frequency and/or exposure time to the source of risk
  - F1 seldom or less often and/or short exposure time
  - F2 frequent or continuous and/or extended exposure time
- P** Possibility of avoiding the risk source or minimizing the injury
  - P1 possible under special conditions
  - P2 hardly possible

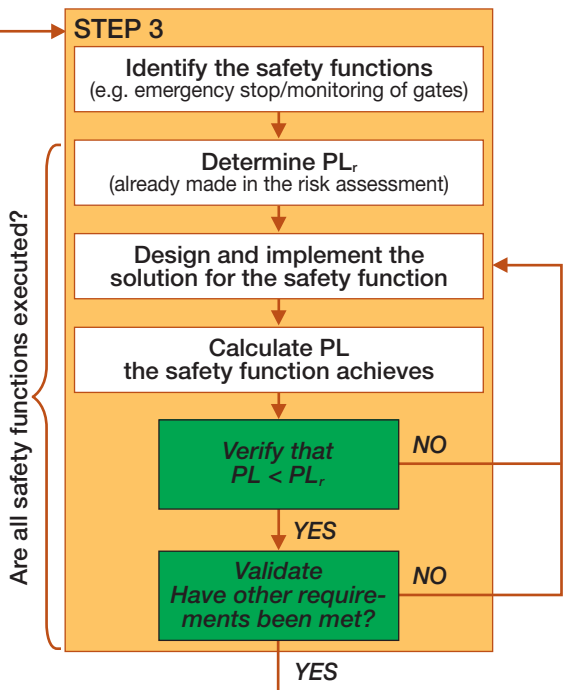
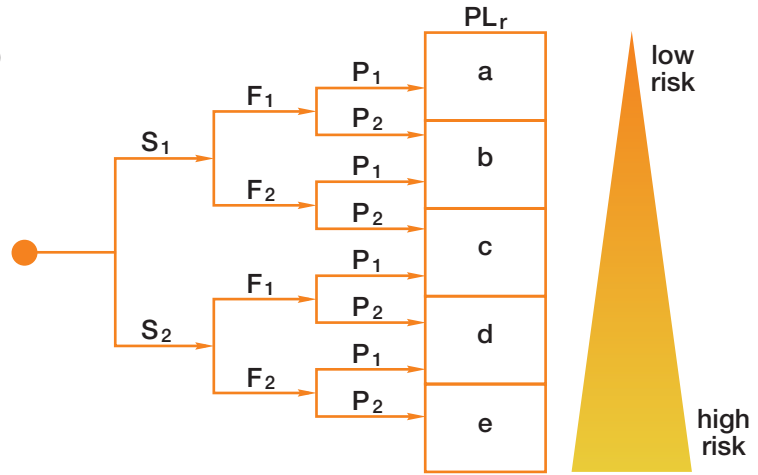

## Step 2 – Reduce the Risk

If you determine that risk reduction is required, you must comply with the priority in the Machinery Directive in the selection of measures:

1. **Avoid the risk already at the design stage.**  
For example, reduce power, avoid interference in the danger zone.
2. **Use protection and/or safety devices.**  
For example, fences, light grids or control devices.
3. **Provide information about how the machine can be used safely.**  
For example, in manuals and on signs.

If risk reduction is performed using safety devices, the control system that monitors these needs to be designed as specified in EN ISO 13849-1.

## Step 3 - Design and Calculate the Safety Functions

To begin with you need to identify the safety functions on the machine. (Examples of safety functions are emergency stop and monitoring of gate.)

For each safety function, a  $PL_r$  should be established—which has often already been made in the risk assessment. The solution for the safety function is then designed and implemented. Once the design is complete, you can calculate the PL the safety function achieves. Check that the calculated PL is at least as high as  $PL_r$  and then validate the system as per the validation plan. The validation checks that the specification of the system is carried out correctly and that the design complies with the specification. You will also need to verify that the requirements that are not included in the calculation of the PL are satisfied—that is, ensure that the software is properly developed and validated, and that you have taken adequate steps to protect the technical approach from systematic errors.

## PL Calculation in Step 3

When you calculate the PL for a safety function, it is easiest to split it into separate, well defined blocks — also called subsystems. It is often logical to make the breakdown according to input, logic and output (e.g. switch - safety relay - contactors), but there may be more than three blocks depending on the connection and the number of components used. For example, an expansion relay could create an additional logic block.

For each block, you calculate a PL or PFH<sub>d</sub>-value. It is easiest if you obtain these values from the component manufacturer, so you do not have to calculate yourself. The manufacturer of switches, sensors and logic devices often have PL and PFH<sub>d</sub>-values for

their components, but for output devices (such as contactors and valves) you do not usually specify a value, as it depends on how often the component will be used. You can then either calculate yourself — according to EN ISO 13849-1— or use the pre-calculated example solutions such as those from ABB Jokab Safety.

To calculate PL or PFH<sub>d</sub> for a block, you need to know its category, DC and MTTF<sub>d</sub>. In addition, you need to protect yourself against systematic errors and ensure that an error does not knock out both channels, and generate and validate any software used correctly. The following text gives a brief explanation of what to do.

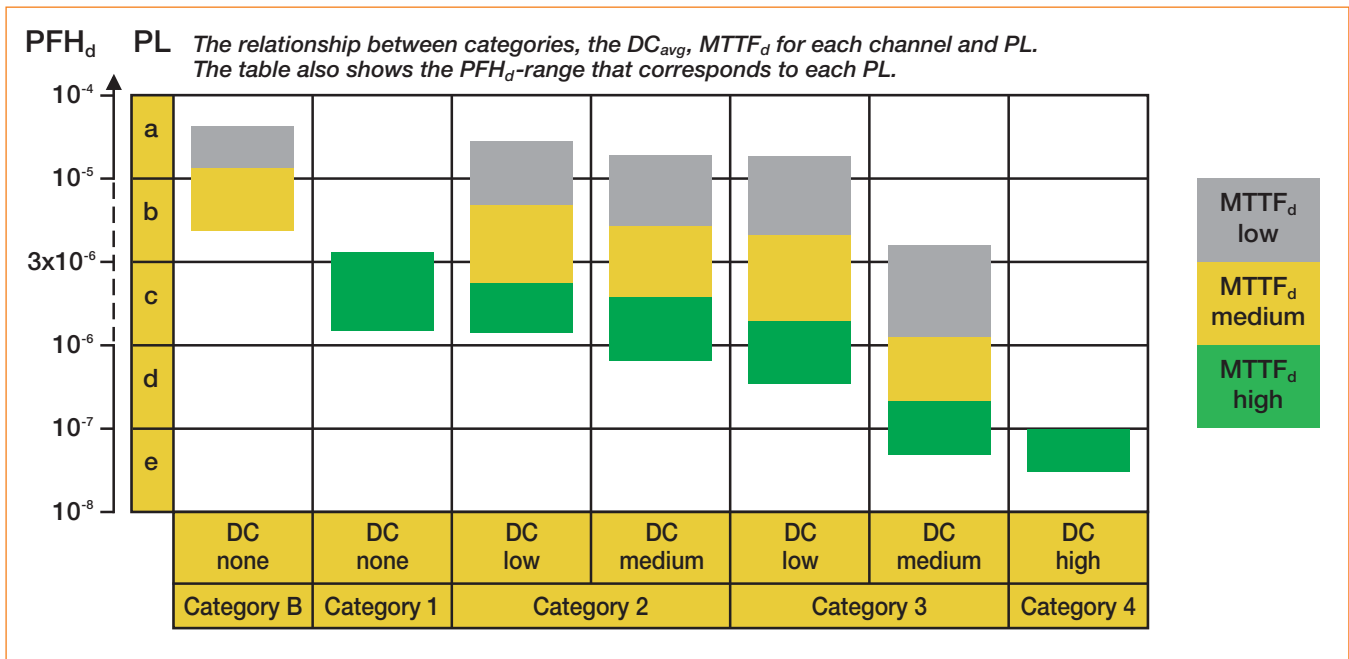

## Safety Function (SF)

$$\text{PFH}_d \text{ Input} + \text{PFH}_d \text{ Logic} + \text{PFH}_d \text{ Output} = \text{PFH}_d \text{ Total}$$



## Category

The structure for the component(s) in the block is assessed to determine the category (B, 1-4) it corresponds to. For category 4, for example, individual failures do not result in any loss of the safety function.

In order to achieve category 4 with contactors, you need to have two channels (*i.e. two contactors*) that can cut the power to the machine individually. The contactors need to be monitored by connecting opening contacts to a test input on, for example a safety relay. For monitoring of this type to work, the contactors need to have contacts with positive opening operation.

## Diagnostic Coverage (DC)

A simple method to determine DC is explained in Appendix E in EN ISO 13849-1. It lists various measures and what they correspond to in terms of DC. For example, DC=99% — which corresponds to DC high — is achieved for a pair of contactors by monitoring the contactors with the logic device.

## Mean Time To Dangerous Failure (MTTF<sub>d</sub>)

In calculating the MTTF<sub>d</sub> for the block, your starting point is the B<sub>10d</sub>-value — average number of cycles until 10% of the components have a dangerous failure. To calculate the MTTF<sub>d</sub>, you also need to know the average number of cycles per year that the component will execute.

Calculation of the average number of cycles is as follows:

$$MTTF_d = \frac{B_{10d}}{0.1 \cdot n_{op}}$$
$$n_{op} = \frac{d_{op} \cdot h_{op} \cdot 3600}{t_{cycle}}$$

$n_{op}$  = Number of cycles/year  
 $d_{op}$  = Operation days/year  
 $h_{op}$  = Operation hours/day  
 $t_{cycle}$  = Cycle time (seconds)

Example:  $d_{op} = 365$  days,  $h_{op} = 24$  hours and  $t_{cycle} = 1,800$  seconds (2 times/hour) which gives  $n_{op} = 17,520$  cycles. With a  $B_{10d} = 2 \cdot 106$ , this gives a  $MTTF_d = 1,141$  year which corresponds to  $MTTF_d = high$ .

Note that when you calculate MTTF<sub>d</sub> you have to calculate according to the total number of cycles the component will be working. A typical example of this is the contactors that frequently work for several safety functions simultaneously. This means that you must add the number of estimated cycles per year from all the safety functions that use the contactors.

For electromechanical, mechanical and pneumatic components whose MTTF<sub>d</sub> is calculated from a B<sub>10d</sub>-value, the following applies.

Also consider that if the MTTF<sub>d</sub>-value is less than 200 years, the component needs to be replaced after 10% of the MTTF<sub>d</sub>-value (*due to the T10<sub>d</sub>-value*).

That is, a component with MTTF<sub>d</sub> = 160 years needs to be replaced after 16 years in order for the conditions for achieving PL to continue to be valid. This is because EN ISO 13849-1 is based on a “mission time” of 20 years.

## Common Cause Failure (CCF)

In Appendix F of EN ISO 13849-1 there is a table of actions to be taken to protect against CCF, to ensure a failure does not knock out both channels.

## Systematic Errors

Appendix G of EN ISO 13849-1 describes a range of actions that need to be taken to protect against incorporating faults into your design.

## PL for Safety Functions

PL is given in the table on the facing page. If you want to use an exact PFH<sub>d</sub>-value instead, this can be produced using a table in Appendix K in EN ISO 13849-1.

Once you have produced the PL for each block, you can generate a total PL for the safety function in Table 11 of EN ISO 13849-1. This gives a rough estimate of the PL. If you have calculated PFH<sub>d</sub> for each block instead, you can get a total of PFH<sub>d</sub> for the safety function by adding together all the values of the blocks. The safety function's total PFH<sub>d</sub> corresponds to a particular PL in Table 3 of EN ISO 13849-1.

## Requirements for Safety-Related Software

If you use a safety PLC for implementing safety functions, this places demands on how the software is developed and validated. To avoid error conditions, the software should be readable, understandable and be possible to test and maintain.

A software specification must be prepared to ensure that you can check the functionality of the program. It is also important to divide the program into modules that can be tested individually. Paragraph 4.6 and Appendix J of EN ISO 13849-1 specify requirements for safety related software.

The following are examples of requirements for software from EN ISO 13849-1:

- A development life cycle must be produced with validation measures that indicate how and when the program should be validated, for example, following a change.
- The specification and design must be documented.
- Function tests must be performed.
- Validated functional blocks must be used whenever possible.
- Data and control flow are to be described using, for example, a condition diagram or software flow chart.

# What defines a Safety Function?

Calculating that you have achieved the PL, that is required is not difficult, especially if you use “pre-calculated” safety devices and logic units. But what parts should then be included in each safety function?

This must be resolved before you start the calculating phase. To summarize in simple terms, you can

say that each safety device gives rise to a safety function for each machine that is affected by the safety device in question. Three safety devices that all cut the power to three machines in a cell is therefore equal to nine safety functions. In the section that follows, we explain the background.

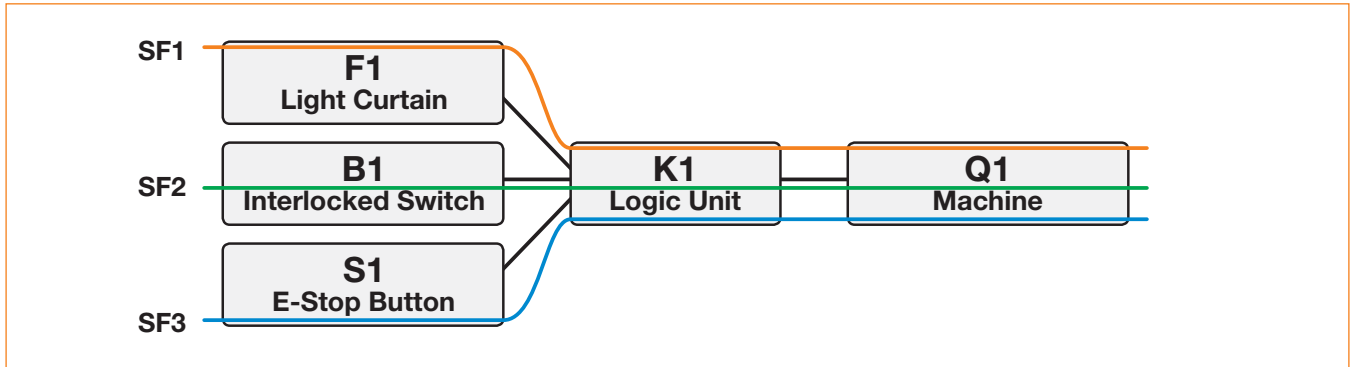

## Multiple Safety Functions for a Machine

Multiple safety devices are often used on a machine in order to provide satisfactory and practical protection for the operators. In the following example, the machine is protected by three safety devices connected to a logic device. The following figure illustrates this interconnection schematically.

Three safety functions (SF) are defined for the machine and are calculated as:

$$SF1: PFH_{d, F1} + PFH_{d, K1} + PFH_{d, Q1} = PFH_{d, SF1}$$

$$SF2: PFH_{d, B1} + PFH_{d, K1} + PFH_{d, Q1} = PFH_{d, SF2}$$

$$SF3: PFH_{d, S1} + PFH_{d, K1} + PFH_{d, Q1} = PFH_{d, SF3}$$

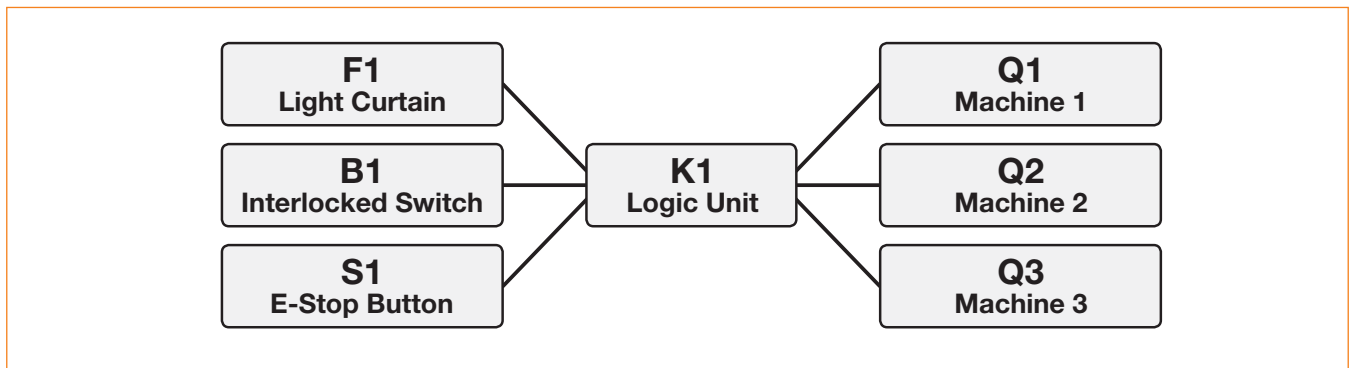

## Multiple Safety Functions for Multiple Machines in a Cell

More commonly, several machines in a single cell—or zone—are to be protected by multiple safety devices. The following figure illustrates the interconnection schematically for an example. Each of the machines Q1 – Q3 is shut down separately and independently of K1.

If the operator enters the cell he is exposed, in this case, to the same type of risk from all three machines. The power to all three machines must be cut when the operator enters the cell through the door interlocked by B1.



### Theoretical Approach for Multiple Machines

The theoretical approach to calculate the safety function is as follows:



For the full safety function to be performed you require all the components to be working. Note that if B1 or K1 has a dangerous malfunction, the entire safety function is disabled. However, if for example machine Q1 has a dangerous malfunction and is not shut down, machines Q2 and Q3 will still be shut down. One disadvantage in considering the safety function in this way is that you may have trouble achieving the  $PL_r$  required. But if you achieve the  $PL_r$  required, you can use the theoretical approach.

**Sources:**

[www.dguv.de/ifa/de/pub/grl/pdf/2009\\_249.pdf](http://www.dguv.de/ifa/de/pub/grl/pdf/2009_249.pdf)  
[www.bg-metall.de/praevention/fachausschuessel/infoblatt/deutsch.html](http://www.bg-metall.de/praevention/fachausschuessel/infoblatt/deutsch.html)  
 (No 047, Date 05/2010)

### Practical Approach for Multiple Machines

A more practical approach is to divide the safety function into three parts, one for each of the three machines.

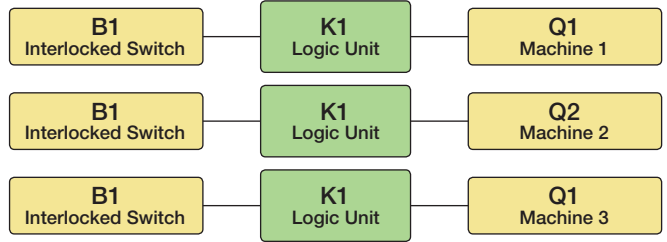

This is an approach that can provide a more accurate way of looking at the safety functions, especially where a different  $PL_r$  is required for the safety functions above. If machine Q1 is a robot and machine Q2 is a conveyor which is designed to have negligible risks, the different  $PL_r$  required to protect against risks from Q1 and Q2 will also be different. This practical approach is therefore the one recommended. The interpretation is based on information provided by IFA (Institut für Arbeitsschutz der Deutschen Gesetzlichen Unfallversicherung). For more information on this and other issues, refer to the Sources provided at the left.

### Example of Safety Functions for Multiple Machines in a Cell

For a cell with three machines (one robot, one hydraulic press and one pneumatic machining tool) a risk assessment is made resulting in different  $PL_r$  for the individual machines. The robot and the hydraulic press requires  $PL_r = e$ , while the pneumatic machining tool requires  $PL_r = d$ .

One of the safety functions is that a non-contact sensor (Eden) supervised by a safety PLC (Pluto) should

disconnect the energy to all three machines in the hazard zone:

- Eden B1 ( $PFH_{d, B1} = 4.5 \cdot 10^{-9}$ )
- Pluto K1 ( $PFH_{d, K1} = 2 \cdot 10^{-9}$ )
- Robot Q1 ( $PFH_{d, Q1} = 5.79 \cdot 10^{-8}$ )
- Hydraulic press Q2 ( $PFH_{d, Q2} = 8 \cdot 10^{-8}$ )
- Pneumatic machining tool Q3 ( $PFH_{d, Q3} = 2 \cdot 10^{-7}$ )

### Practical Approach

If you use the practical approach the safety functions are as follows:

**Robot:**  $PFH_{d, B1} + PFH_{d, K1} + PFH_{d, Q1} = 4.5 \cdot 10^{-9} + 2 \cdot 10^{-9} + 5.79 \cdot 10^{-8} = 6.44 \cdot 10^{-8} \longrightarrow PL e$

**Hydraulic Press:**  $PFH_{d, B1} + PFH_{d, K1} + PFH_{d, Q2} = 4.5 \cdot 10^{-9} + 2 \cdot 10^{-9} + 8 \cdot 10^{-8} = 8.65 \cdot 10^{-8} \longrightarrow PL e$

**Pneumatic Machining Tool:**  $PFH_{d, B1} + PFH_{d, K1} + PFH_{d, Q3} = 4.5 \cdot 10^{-9} + 2 \cdot 10^{-9} + 2 \cdot 10^{-7} = 2.07 \cdot 10^{-7} \longrightarrow PL d$

This is to be done in a similar way with other safety functions for the cell. For each safety device, you define the machines it affects, and establish the various safety functions according to this.

### Theoretical Approach

How would it have worked if you had used the theoretical approach? Would the safety function have achieved  $PL e$ ?

**All machines:**  $PFH_{d, B1} + PFH_{d, K1} + PFH_{d, Q1} + PFH_{d, Q2} + PFH_{d, Q3} = 4.5 \cdot 10^{-9} + 2 \cdot 10^{-9} + 5.79 \cdot 10^{-8} + 8 \cdot 10^{-8} + 2 \cdot 10^{-7} = 3.44 \cdot 10^{-7} \longrightarrow PL d$

In this case, the safety function would therefore have not achieved a total  $PL e$ , which was required for the risks associated with a robot and hydraulic press.

*Note: The examples on these pages are simplified in order to explain the principles. Values of products can also change.*

### Conclusions

- Use the practical approach.
- Use safety devices/logic units with high reliability (low  $PFH_d$ ) to make it easy to achieve the  $PL_r$  required.
- With Vital or Pluto, it is easier to achieve the  $PL_r$  required.

# Applying EN 62061

If you choose to design a safety function in accordance with EN 62061, the level of reliability is expressed as the **Safety Integrity Level—SIL**. There are a total of 4 levels, but in the EN 62061 standard SIL 3 is the highest level. SIL, similar to the Performance Level (PL), is also expressed as the **Probability of Dangerous Failure Per Hour—PFH<sub>d</sub>**.

SIL	PFH <sub>d</sub>
3	≥ 10 <sup>-8</sup> to >10 <sup>-7</sup>
2	≥ 10 <sup>-7</sup> to >10 <sup>-6</sup>
1	≥ 10 <sup>-6</sup> to >10 <sup>-5</sup>

## Method in EN 62061 for assigning the Safety Integrity Level (SIL)

Severity (Se)	Class (CI)				
	3-4	5-7	8-10	11-13	14-15
4	SIL2	SIL2	SIL2	SIL3	SIL3
3		(OM)	SIL1	SIL2	SIL3
2			(OM)	SIL1	SIL2
1				(OM)	SIL1

Note: CI = Fr + Pr = AV; OM = Other Measures

### Definition of protective safety in accordance with EN 62061:

*“Function of a machine whose failure can result in an immediate increase of the risk(s)”*

The seriousness of injury that can occur is defined at one of four levels. Class is the addition of the values of frequency (Fr, stated as a value between 1 and 5, where 5 represents the highest frequency), probability that a dangerous event will occur (Pr, stated as a value between 1 and 5, where 5 represents the highest probability) and the possibility of avoiding or limiting injury (Av, stated as a value of 1, 3 or 5, where 5 represents the least chance of avoiding or limiting an injury).

The safety function that is to be designed must at least fulfill the SIL that has been assigned to it in the analysis. The safety function consists of a number of sub-elements.

**Example:** A door is interlocked by a non-contact sensor which is in turn monitored by a Pluto safety PLC, with outputs that break the power to two supervised contactors. The sensor is sub-element 1, Pluto is sub-element 2 and the two supervised contactors are sub-element 3. If in the analysis it has been established that SIL2 shall be used, every individual sub-element in the safety function must fulfill the SIL2 requirements. The safety function must then in its entirety fulfill the SIL2 requirements.

If the SIL requirements are not fulfilled in any of the sub-elements or by the safety function in its entirety, there must be a redesign.

You will get the PFH<sub>d</sub> values of our products when you contact us.

### In conclusion...

This is just a brief introduction to the EN ISO 13849-1 and EN 62061 standards. You are welcome to contact us so that we can prepare suitable training and guide you in how to apply the standards to our products.

# A Mechanical Switch does not give a Safe Function!

When it comes to mechanically operated interlocked switches, it has long been accepted that a Category 1 switch is adequate for many installations, which is also supported by several standards. However, some companies have now re-evaluated this and have instead started to demand two mechanical switches or non-contact switches/sensors, where they previously accepted single mechanical switches. Many reported incidents form the background to this.

The requirements for switches to provide safe functioning are that they are mounted correctly and that their positions do not change during their life-cycle—in other words, ideal conditions. In many installations the location of hatches or doors changes over time. This has led to a switch not giving a stopping signal when an interlocked gate has opened. The reasons for this are many, but they can be summarized in mechanical deterioration or physical damage to a door/hatch. In turn this has led to an interlocked switch being affected by higher stress than the switch manufacturer's specifications. To avoid this type of malfunction it is more appropriate to use non-contact switches/sensors because mechanical deterioration does not affect the safety function, i.e. the stop signal is given directly if the position is wrong.

A non-contact switch/sensor does not have a guided function and is designed to fulfill the requirements in another way. The requirements are fulfilled either with dynamic sensors where the safety signal is monitored all the time and a fault directly leads to a stop signal or with a magnetic switch which has two independent contact elements which are monitored every time a gate opens. From the user's perspective the dynamic function is preferable because several sensors can be connected to a single safety module and still achieve PL e. Also, the sensor's safety function is monitored without having to open a gate. For a magnetic switch the requirements for PL e are only fulfilled if one switch per monitoring unit is used and if the gate is opened regularly.

If PL e is to be achieved with electromechanical switches, maximum of two switches can be connected

to one safety relay. This means that it is only with Eden that several doors can be supervised with one safety module and achieve PL e.

Since the standard EN 954-1 was written, development has progressed and the costs to fulfill category 4 have dropped dramatically. Generally mechanical switches are replaced with non-contact sensors to increase the reliability of production equipment. The same goes for the safety side. With electronic non-contact switches, with a transmitter and a receiver, one avoids the problems of deterioration and excessive stress which harm the sensor. For that kind of sensor dynamic monitoring is required to enable a safe function. This means that its function is constantly being monitored, hundred of times per second. The reaction time for a safe stop will then be the same during a malfunction as during the activation of a stop (e.g. a gate opening). The monitoring frequency will also be astronomical compared to that of mechanical switches and magnetic switches, which are only monitored every time they are used.

In the new EN ISO 13849-1, which will replace 954-1, probability calculations are used together with different category levels to compare different "performance levels". Even when using EN ISO 13849-1, one can achieve reasonably high theoretical reliability with an electromechanical switch, although this presumes correct installation, proper use and otherwise ideal conditions. A non-contact switch instead provides high levels of both theoretical and practical reliability.

## Our Conclusion, Use Dynamic Signals!

Our conclusion is that today it is more cost effective, safer and more reliable to work with dynamic signals to achieve category 4 for sensors and monitoring units.

In that case, it is also possible to fulfill the Machinery Directive, 1.2.7. requirement: **"A fault in the control circuit logic, or failure of or damage to the control circuit, must not lead to dangerous situations"**. Also one does not have to discuss whether the correct safety category has been chosen!

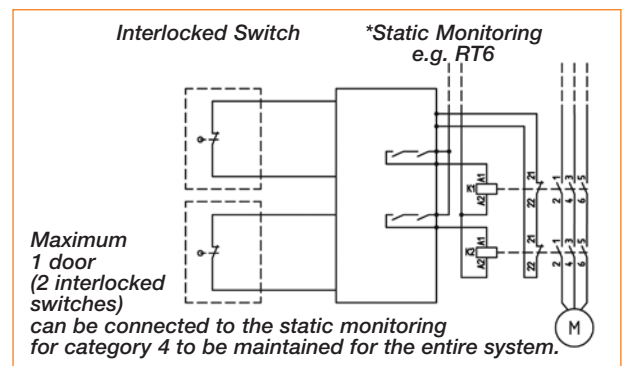
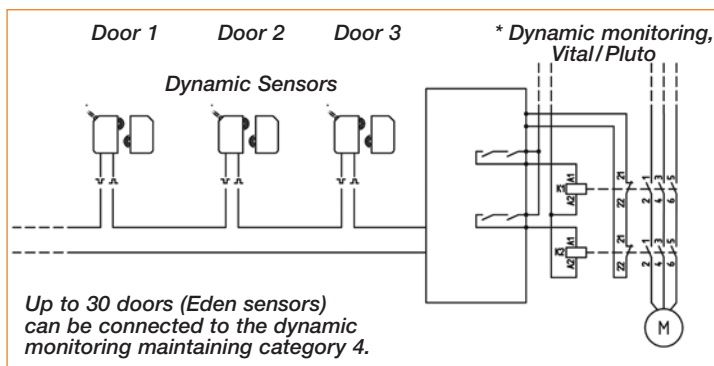

# Safety Standards Organizations and Information Sources

**Automotive Industry Action Group (AIAG)**  
26200 Lahser Road  
Suite 200  
Southfield, MI 48034  
Tel: 248-358-3570  
Fax: 248-358-3253  
[www.aiag.org](http://www.aiag.org)

AIAG is a globally recognized organization founded in 1982 by a group of visionary managers from DaimlerChrysler, Ford Motor Company, and General Motors. The purpose: to provide an open forum where members cooperate in developing and promoting solutions that enhance the prosperity of the automotive industry. AIAG's focus is to continuously improve business processes and practices involving trading partners throughout the supply chain. Under the auspices of AIAG, volunteers from approximately 1,500 member companies have worked together to resolve issues critical to the automotive supply chain. AIAG members play a unique role in the development of new technologies and the standards that govern their usage.

---

**American National Standards Institute (ANSI)**  
1819 L Street NW  
Washington DC 20036  
Tel: 202-293-8020  
Fax: 202-293-9287  
[www.ansi.org](http://www.ansi.org)

ANSI is a private, non-profit organization (501(c)3) that administers and coordinates the U.S. voluntary standardization and conformity assessment system. The Institute's mission is to enhance both the global competitiveness of U.S. business and the U.S. quality of life by promoting and facilitating voluntary consensus standards and conformity assessment systems, and safeguarding their integrity.

---

**American Society of Mechanical Engineers (ASME)**  
3 Park Avenue  
New York, NY 10016-5990  
Tel: 212-591-7722  
Fax: 212-591-7674  
[www.asme.org](http://www.asme.org)

Founded in 1880 as the American Society of Mechanical Engineers, today ASME International is a nonprofit educational and technical organization serving a worldwide membership of 125,000. The work of the Society is performed by its member-elected Board of Governors and through its five Councils, 44 Boards and hundreds of Committees in 13 regions throughout the world. There are a combined 400 sections and student sections serving ASME's worldwide membership. The ASME vision is to be the premier organization for promoting the art, science and practice of mechanical engineering throughout the world. Our mission is to promote and enhance the technical competency and professional well-being of our members, and through quality programs and activities in mechanical engineering, better enable its practitioners to contribute to the well-being of humankind.

---

**American Society of Safety Engineers (ASSE)**  
Customer Service  
1800 East Oakton Street  
Des Plaines, IL 60018  
Tel: 847-699-2929  
Fax: 847-768-3434  
[www.asse.org](http://www.asse.org)

Founded in 1911, ASSE is the oldest and largest professional safety organization. More than 30,000 members manage, supervise and consult on safety, health, and environmental issues in industry, insurance, government and education. ASSE is guided by a 16-member Board of Directors, which consists of 8 regional vice presidents; three council vice presidents; Society president, president-elect, senior vice president, vice president of finance and executive director. ASSE has 12 practice specialties, 150 chapters, 56 sections and 64 student sections.

**American Welding Society (AWS)**  
550 N.W. LeJeune Road  
Miami, FL 33135  
Tel: 305-443-9353  
Fax: 305-443-7559  
[www.aws.org](http://www.aws.org)

AWS was founded in 1919 as a multifaceted, nonprofit organization with a goal to advance the science, technology and application of welding and related joining disciplines. From factory floor to high-rise construction, from military weaponry to home products, AWS continues to lead the way in supporting welding education and technology development to ensure a strong, competitive and exciting way of life for all Americans. AWS serves 50,000 members worldwide. Membership consists of engineers, scientists, educators, researchers, welders, inspectors, welding foremen, company executives and officers, and sales associates. Interests include automatic, semi-automatic and manual welding, as well as brazing, soldering, ceramics, lamination, robotics, and welding safety and health.

---

**Canadian Center for Occupational Health and Safety (CCOHS)**  
250 Main Street East  
Hamilton, ON  
L8N 1H6 Canada  
Tel: 800-668-4284  
Fax: 905-527-2206  
[www.ccohs.ca](http://www.ccohs.ca)

CCOHS offers many innovative OH&S products and services. These include print and electronic publications, databases, person-to-person inquires and certified education and training courses.

---

**Canadian Standards Association (CSA)**  
5060 Spectrum Way  
Suite 100  
Mississauga, ON  
L4W 5N6 Canada  
Tel: 416-747-4000  
Fax: 416-747-2473  
[www.csa.ca](http://www.csa.ca)

Making Standards Work for People and Business, the CSA is a not-for-profit membership-based association serving business, industry, government and consumers in Canada and the global marketplace. As a solutions-oriented organization, we work in Canada and around the world to develop standards that address real needs, such as enhancing public safety and health. Advancing the quality of life. Helping to preserve the environment. Facilitating trade. We help people understand standards through education and information products and services. Each year, thousands of people benefit from the training materials, workshops and seminars offered by the CSA.

---

**Conveyor Equipment Manufacturers Association (CEMA)**  
6724 Lone Oak Boulevard  
Naples, FL 34109  
Tel: 941-514-3441  
Fax: 941-514-3470  
[www.cemanet.org](http://www.cemanet.org)

From 1933 to 2001, CEMA was the voice of the Manufacturers (MA) of conveyors and conveying components in the United States. In 2001 it expanded its membership to include Canadian and Mexican manufacturers in conjunction with the development of the NAFTA. In 2001 it also expanded to include a new class of membership called Technical Membership (TE) for conveyor engineering and system design companies who do not manufacture conveyors. CEMA's purpose is to promote, among its members and the industry, standardization of design, manufacture, and application on a voluntary basis and in such manner as will not impede development of conveying machinery and component parts or lessen competition.

**CENELEC**

35, Rue de Stassart  
1050 Brussels  
Tel: +32 2 519 68 71  
Fax: +32 2 519 69 19  
[www.cenelec.org](http://www.cenelec.org)

CENELEC is the European Committee for Electrotechnical Standardization. It was set up in 1973 as a non-profit-making organization under Belgian Law. It has been officially recognized as the European Standards Organization in its field by the European Commission in Directive 83/189/EEC. Its members have been working together in the interests of European harmonization since the late fifties, developing alongside the European Economic Community. CENELEC works with 35,000 technical experts from 19 European countries to publish standards for the European market.

**DNV**

Veritasveien 1  
1322 Høvik  
Oslo, Norway  
Tel: +47 67 57 99 00  
Fax: +47 67 57 99 11  
[www.dnv.com](http://www.dnv.com)

Established in 1864, DNV is an independent foundation with the objective of safeguarding life, property and the environment and is a leading international provider of services for managing risk. DNV is an international company with about 300 offices in 100 different countries, headquartered in Oslo, Norway.

**EN**

European Community Standards (European Norm) are available from CEN, CENELEC, ANSI and from Global (see listings included).

**Electrical Safety  
Foundation International (ESFI)**

1300 North 17th Street  
Suite 1752  
Rosslyn, VA 22209  
Tel: 703-841-3229  
Fax: 703-841-3329  
[www.electrical-safety.org](http://www.electrical-safety.org)

The ESFI was founded as a nonprofit in 1994 in a joint effort by the National Electrical Manufacturers Association (NEMA), Underwriters Laboratories (UL) and the U.S. Consumer Product Safety Commission (CPSC). The Foundation was established to promote electrical safety in the home, school and workplace through public education about electrical hazards and the preventative measures we can take to avoid property damage, litigation, personal injury and death due to electrical accidents.

**European Committee  
for Standardization (CEN)**

36, Rue de Stassart  
B-1050 Brussels  
Tel: +32 2 550 08 11  
Fax: +32 2 550 08 19  
[www.cenorm.be](http://www.cenorm.be)

CEN's mission is to promote voluntary technical harmonization in Europe in conjunction with worldwide bodies and its partners in Europe. Harmonization diminishes trade barriers, promotes safety, allows interoperability of products, systems and services, and promotes common technical understanding. In Europe, CEN works in partnership with CENELEC—the European Committee for Electrotechnical Standardization ([www.cenelec.org](http://www.cenelec.org)) and ETSI—the European Telecommunications Standards Institute.

**European Organization for  
Conformity Assessment (EOTC)**

36, Rue de Stassart  
B-1050 Brussels  
Tel: +32 2 502 41 41  
Fax: +32 2 502 42 39  
[www.eotc.be](http://www.eotc.be)

The EOTC, an independent and non-profit making European body, was established in April 1990 by the European Commission, the European Free Trade Association (EFTA) and the European Standards Bodies. Articles of Association were signed by 22 founder members on 3 December 1992 and the EOTC attained a legal status under Belgian Law in April 1993. The EOTC is run by a General Assembly (GA), with Board of Administrators (BoA), elected from the GA, responsible for developing policy and strategic planning, meeting four times per year.

**EuroPort**

29 Waterman Road  
Gloucester MA 01930  
Tel: 978-282-8895  
Fax: 978-282-9788  
[www.europort.com](http://www.europort.com)

EuroPort is an official British Standards Institution (BSI) distributor of international standards and publications. If exporting equipment to the global marketplace is key to your business, EuroPort will help you succeed with our standards/norms, publications and UL-approved CE and safety labels.

---

**Global Engineering Documents**

A Division of Information  
Handling Services  
15 Inverness Way East  
Englewood, CO 80112  
Tel: 800-624-3974  
Fax: 303-792-2192  
[www.global.ihs.com](http://www.global.ihs.com)

Global Engineering Documents is a division of the information company, IHS Engineering, founded in 1959. Global Engineering Documents offers a broad base of engineering data from research and design to manufacturing and repair. The product offering provides customers with timesaving tools that not only help to increase productivity, but help to stay on the cutting-edge of technology and ahead of the competition. Global is the world's most comprehensive source of hardcopy technical industry standards and government and military standards. Additionally, Global publishes a variety of highly acclaimed reference books, manuals, and comprehensive guides.

---

**Industrial Accident  
Prevention Association (IAPA)**

Centre for Health & Safety Innovation  
5110 Creekbank Road  
Suite 300  
Mississauga, ON  
L4W 0A1 Canada  
Tel: 800-406-IAPA (4272)  
Fax: 905-614-1414  
[www.iapa.ca](http://www.iapa.ca)

The IAPA is a not-for-profit, member-driven organization operating in the Province of Ontario since 1917. Representing more than 50,000 member firms and more than 1.5 million workers, IAPA is Canada's largest health and safety organization and has taken a leading role in the prevention of workplace injury and illness, working for improvement in the health and safety performance of our member firms.

---

**International Electrotechnical  
Commission (IEC)**

3, Rue de Varembe  
CH-1211 Geneva 20  
Switzerland  
Tel: 41 22 919-01-11  
Fax: 41 22 919-03-00  
[www.iec.ch](http://www.iec.ch)

IEC is the leading global organization that prepares and publishes international standards for all electrical, electronic and related technologies. These serve as a basis for national standardization and as references when drafting international tenders and contracts. Through its members, the IEC promotes international cooperation on all questions of electrotechnical standardization and related matters, such as the assessment of conformity to standards, in the fields of electricity, electronics and related technologies.

---

**International Standards  
Organization (ISO)**

1, Rue de Varembe  
Case postale 56  
CH-1211 Geneva 20  
Switzerland  
Tel: +41 22 749 01 11  
Fax: +41 22 733 34 30  
[www.iso.ch](http://www.iso.ch)

“The ISO is a worldwide federation of national standards bodies from more than 140 countries, one from each country. ISO is a non-governmental organization established in 1947. The mission of ISO is to promote the development of standardization and related activities in the world with a view to facilitating the international exchange of goods and services, and to developing cooperation in the spheres of intellectual, scientific, technological and economic activity. ISO's work results in international agreements which are published as International Standards.”

**Ministry of Labour  
Province of Ontario (MLPO)**  
400 University Avenue  
11th Floor  
Toronto, ON  
M7A 1T7 Canada  
Tel: 416-326-7950  
Fax: 416-326-7985  
[www.gov.on.ca](http://www.gov.on.ca)

Safe, fair and healthy workplaces characterized by productive relationships and high performance drive a vibrant, competitive economy and generate widespread benefits for all. The MLPO contributes to achieving this vision and to the prosperity of Ontario by advancing health, safety, fairness and productive relationships in the workplace and the broader community.

---

**National Fire Protection  
Association (NFPA)**  
1 Batterymarch Park  
Quincy, MA 02269-9101  
Tel: 617-770-3000  
Fax: 617-770-0700  
[www.nfpa.org](http://www.nfpa.org)

The mission of the international nonprofit NFPA is to reduce the worldwide burden of fire and other hazards on the quality of life by providing and advocating scientifically-based consensus codes and standards, research, training and education.

---

**National Institute of Standards  
and Technology (NIST)**  
100 Bureau Drive, Stop 3460  
Gaithersburg, MD 20899-3460  
Tel: 301-975-6478  
Fax: 301-975-8295  
[www.nist.gov](http://www.nist.gov)

From automated teller machines and atomic clocks to mammograms and semiconductors, innumerable products and services rely in some way on technology, measurements, and standards provided by the NIST. Founded in 1901, NIST is a non-regulatory federal agency within the U.S. Commerce Department's Technology Administration. NIST's mission is to develop and promote measurements, standards, and technology to enhance productivity, facilitate trade, and improve the quality of life. NIST carries out its mission in four cooperative programs.

---

**National Safety Council (NSC)**  
1121 Spring Lake Drive  
Itasca, IL 60143-3201  
Tel: 630-281-1121  
Fax: 630-281-1315  
[www.nsc.org](http://www.nsc.org)

The NSC, founded in 1913 and chartered by the United States Congress in 1953, is the nation's leading advocate for safety and health. Our mission is "to educate and influence society to adopt safety, health and environmental policies, practices and procedures that prevent and mitigate human suffering and economic losses arising from preventable causes".

---

**National Electrical Manufacturers  
Association (NEMA)**  
1300 North 17th Street  
Rosslyn, VA 22209  
Tel: 703-841-3200  
Fax: 703-841-5900  
[www.nema.org](http://www.nema.org)

NEMA, created in the fall of 1926 by the merger of the Electric Power Club and the Associated Manufacturers of Electrical Supplies, provides a forum for the standardization of electrical equipment, enabling consumers to select from a range of safe, effective and compatible electrical products. The organization has also made numerous contributions to the electrical industry by shaping public policy development and operating as a central confidential agency for gathering, compiling, and analyzing market statistics and economics data.



**Occupational Safety and Health Administration (OSHA)**

200 Constitution Avenue  
Washington, DC 20210  
Tel: 800-321-OSHA (6742)  
[www.osha.gov](http://www.osha.gov)

The mission of the Occupational Safety and Health Administration (OSHA) is to save lives, Prevent injuries and protect the health of America's workers. To accomplish this, federal and state governments must work in partnership the more than 100 million working men and women and their six and a half million employers who are covered by the Occupational Safety and Health Act of 1970.

---

**Robotic Industries Association (RIA)**

900 Victors Way  
P.O. Box 3724  
Ann Arbor, MI 48106  
Tel: 734-994-6088  
Fax: 734-994-3338  
[www.robotics.org](http://www.robotics.org)

Robotics Online is sponsored by Robotic Industries Association, and provides information to help engineers, managers and executives apply and justify robotics and flexible automation. Founded in 1974, RIA is the only trade group in North America organized specifically to serve the robotics industry. Member companies include leading robot manufacturers, users, system integrators, component suppliers, research groups, and consulting firms.

---

**The Society of Automotive Engineers (SAE)**

400 Commonwealth Drive  
Warrendale, PA 15096-0001  
Tel: 724-776-4841  
Fax: 724-776-5760  
[www.sae.org](http://www.sae.org)

Over 83,000 engineers, business executives, educators, and students from more than 97 countries form SAE's network of membership who share information and exchange ideas for advancing the engineering of mobility systems. More than 16,000 volunteer leaders serve on our Board of Directors and our many other boards, councils and committees. Our technical committees write more new aerospace and automotive engineering standards than any other standards-writing organization in the world. We publish thousands of technical papers and books each year, and leading-edge periodicals and Internet and CD-ROM products too. Our Cooperative Research Program helps facilitate projects that benefit the mobility industry as a whole. Numerous meetings and exhibitions provide worldwide opportunities to network and share information. We also offer a full complement of professional development activities such as seminars, technical symposia, and e-learning products. The meetings and activities of local sections provide an opportunity to network with colleagues near you.

---

**Standards Council of Canada (SCC)**

270 Alberta Street  
Suite 200  
Ottawa, ON  
K1P 6N7 Canada  
Tel: 613-238-3222  
Fax: 613-569-7808  
[www.scc.ca](http://www.scc.ca)

The SCC is a federal Crown corporation with the mandate to promote efficient and effective standardization. Located in Ottawa, the Standards Council has a 15-member governing Council and a staff of approximately 80. The organization reports to Parliament through the Minister of Industry and oversees Canada's National Standards System.

**Society of Manufacturing Engineers (SME)**

P. O. Box 930  
One SME Drive  
Dearborn, MI 48121-0930  
Tel: 313-271-1500  
Fax: 313-271-2861  
[www.sme.org](http://www.sme.org)

The SME is the world's leading professional society supporting manufacturing education. Through its member programs, publications, expositions, and professional development resources, SME promotes an increased awareness of manufacturing engineering and helps keep manufacturing professionals up to date on leading trends and technologies. SME influences more than half a million manufacturing engineers and executives annually. The Society has members in 70 countries and is supported by a network of hundreds of chapters worldwide.

---

**The Society of the Plastics Industry, Inc. (SPI)**

1667 K Street NW  
Suite 1000  
Washington, DC 20006  
Tel: 202-974-5200  
Fax: 202-296-7005  
[www.plasticsindustry.org](http://www.plasticsindustry.org)

Founded in 1937, the SPI is the trade association representing one of the largest manufacturing industries in the United States. SPI's members represent the entire plastics industry supply chain, including processors, machinery and equipment manufacturers and raw material suppliers. The U.S. plastics industry employs more than 1.3 million workers and provides more than \$345 billion in annual shipments. The mission of SPI is to be a world class trade association representing the entire plastics industry in a way that promotes the development of the plastics industry and enhances the public's understanding of its contributions while meeting the needs of society and providing value to its members.

---

**TUV America, Inc. (TUV)**

5 Cherry Hill Drive  
Danvers, MA 01923  
Tel: 800-TUV-0123  
Fax: 987-777-8441  
[www.TUVamerica.com](http://www.TUVamerica.com)

"Our primary mission to industry and to the consumer is... Making Progress Safe". This, above all else, is why we exist — To protect the health and safety of consumers and the environment by helping industry produce safer, better products. Through our work, consumers improve their overall quality of life. Our industry customers work with us to achieve product differentiation and competitive advantage through better methods and technology in research, design, development, manufacturing and service. Our reports and certificates prove that the customer complies with applicable regulations or guidelines, and in many cases, goes well beyond minimally acceptable standards to achieve best-in-class status.

---

**Underwriters Laboratories, Inc. (UL)**

333 Pfingsten Road  
Northbrook, IL 60062-2096  
Tel: 877-ULHELPS (854-3577)  
Fax: 847-407-1395  
[www.ul.com](http://www.ul.com)

UL is an independent, not-for-profit product safety certification organization that has been testing products and writing Standards for Safety for over a century. UL evaluates more than 19,000 types of products, components, materials and systems annually with 21 billion UL Marks appearing on 71,000 manufacturers' products each year. UL's worldwide family of companies and network of service providers includes 66 laboratory, testing and certification facilities serving customers in 104 countries.

**U.S. Fire Administration (USFA)**  
16825 South Seton Avenue  
Emmitsburg, MD 21727  
Tel: 301-447-1000  
Fax: 301-447-1346  
[www.usfa.fema.gov](http://www.usfa.fema.gov)

As an entity of the Federal Emergency Management Agency, the mission of the USFA is to reduce life and economic losses due to fire and related emergencies, through leadership, advocacy, coordination and support. We serve the Nation independently, in coordination with other Federal agencies, and in partnership with fire protection and emergency service communities. With a commitment to excellence, we provide public education, training, technology and data initiatives.

---

**Woodworking Machinery Industry Association (WMIA)**  
3313 Paper Mill Road  
Suite 202  
Phoenix, MD 21131  
Tel: 410-628-1970  
Fax: 410-628-1972  
[www.wmia.org](http://www.wmia.org)

For more than 30 years the WMIA has provided the North American wood products industry with the most technologically advanced woodworking systems available in the global market. Our more than 170 members are dedicated to providing their customers with the service and knowledge to compete worldwide. A wide range of special programs provide industry awards, scholarships and a host of other methods to support industry initiatives and address industry issues. In the years to come WMIA will continue its commitment to providing a world of woodworking technology to its customers and provide leadership necessary to keep the North American wood products industry competitive.

---

**Wood Machinery Manufacturers of America (WMMA)**  
100 North 20th Street  
4th Floor  
Philadelphia, PA 19103-1443  
Tel: 215-564-3484  
Fax: 215-963-9785  
[www.wmma.org](http://www.wmma.org)

For over 100 years, the WMMA has worked to increase the productivity and profitability of U.S. machinery and tooling manufacturers and the businesses that support them. Over that time, WMMA has dedicated itself to the advancement of the U.S. woodworking machinery and cutting tool industry while promoting awareness of American technology in the woodworking industry. Today, through an extensive variety of Association programs and services, designed by and for members, WMMA is the resource for all member companies to achieve their ultimate and common goal—that of Profit Through American Technology.

# Machine Safety Standards

## US STANDARDS

Standard	Number	Type	Description
ANSI	B11.1	Mechanical Power Presses	Safety Requirements for Construction, Care and Use
ANSI	B11.2	Hydraulic Power Presses	Safety Requirements for Construction, Care and Use
ANSI	B11.3	Power Press Brakes	Safety Requirements for Construction, Care and Use
ANSI	B11.4	Shears	Safety Requirements for Construction, Care and Use
ANSI	B11.5	Iron Workers	Safety Requirements for Construction, Care and Use
ANSI	B11.6	Lathes	Safety Requirements for Construction, Care and Use
ANSI	B11.7	Cold Headers and Cold Formers	Safety Requirements for Construction, Care and Use
ANSI	B11.8	Drilling, Milling and Boring	Safety Requirements for Construction, Care and Use
ANSI	B11.9	Grinding Machines	Safety Requirements for Construction, Care and Use
ANSI	B11.10	Metal Sawing Machines	Safety Requirements for Construction, Care and Use
ANSI	B11.11	Gear Cutting Machines	Safety Requirements for Construction, Care and Use
ANSI	B11.12	Roll Forming and Roll Bending Machines	Safety Requirements for Construction, Care and Use
ANSI	B11.13	Automatic Bar and Chucking Machines	Safety Requirements for Construction, Care and Use
ANSI	B11.14	Coil Slitting Machines	Safety Requirements for Construction, Care and Use
ANSI	B11.15	Pipe Tube and Shape Bending Machines	Safety Requirements for Construction, Care and Use
ANSI	B11.16	Metal Powder Compacting Presses	Safety Requirements for Construction, Care and Use Administratively Withdrawn 7/28/2000
ANSI	B11.17	Horizontal Hydraulic Extrusion Presses	Safety Requirements for Construction, Care and Use
ANSI	B11.18	Horizontal Hydraulic Extrusion Presses	Safety Requirements for Construction, Care and Use

## US STANDARDS continued

Standard	Number	Type	Description
ANSI	B11.19	Safeguarding as Referenced in the other B11 Machine Tool Safety Standards	Performance Criteria for the Design, Construction, Care and Operation
ANSI	B11.20	Manufacturing Systems/Cells	Safety Requirements for Construction, Care and Use

## CANADIAN STANDARDS

Standard	Number	Type	Description
CSA	Z142	Code for Power Press Operation: Health, Safety and Guarding Requirements	
CSA	434	Safeguarding of Robot	
CSA	432	General Machine Safeguarding	

## EUROPEAN/INTERNATIONAL STANDARDS

Standard	Type	Description
EN ISO 12100 (replaces EN ISO 12100-1/-2 and EN ISO 14121-1)	Safety of machinery – General principles for design – Risk assessment and risk reduction	Part 1: This standard defines basic terminology and methodology used in achieving safety of machinery. The provisions stated in this standard are intended for the designer. Part 2: This standard defines technical principles to help designers in achieving safety in the design of machinery.
EN ISO 13857	Safety of machinery – Safety distances to prevent hazard zones being reached by upper and lower limbs	This standard establishes values for safety distances to prevent danger zones being reached by the upper limbs. The distances apply when adequate safety can be achieved by distances alone.
EN 349 (ISO 13854)	Safety of machinery – Minimum gaps to avoid crushing of parts of the human body	The object of this standard is to enable the user (e.g. standard makers, designers of machinery) to avoid hazards from crushing zones. It specifies minimum gaps relative to parts of the human body and is applicable when adequate safety can be achieved by this method.

## EUROPEAN/INTERNATIONAL STANDARDS continued

Standard	Type	Description
EN ISO 13850	Safety of machinery – Emergency stop – Principles for design	This standard specifies design principles for emergency stop equipment for machinery. No account is taken of the nature of the energy source.
EN 574	Safety of machinery – Two-hand control devices – Functional aspects – Principles for design characteristics of two-hand control devices	This standard specifies the safety requirements of a two-hand control device and its logic unit. The standard describes the main characteristics of two-hand control devices for the achievement of safety and sets out combinations of functional characteristics for three types.
EN 953 and movable guards	Safety of machinery – Guards – General requirements for the design and construction of fixed mechanical hazards.	This standard specifies general requirements for the design and construction of guards provided primarily to protect persons
EN ISO 13849-1 (replaces EN 954-1)	Safety of machinery – Safety related parts of control systems – Part 1: General principles for design	This standard provides safety requirements and guidance on the principles for the design (see 3.11 of EN 292-1:1991) of safety related parts of control systems. For these parts it specifies categories and describes the characteristics of their safety functions. This includes programmable systems for all machinery and for related protective devices. It applies to all safety-related parts of control systems, regardless of the type of energy used, e.g. electrical, hydraulic, pneumatic, mechanical. It does not specify which safety functions and which categories should be used in a particular case.
EN ISO 13849-2 Validation	Safety of machinery. Safety-related parts of control systems.	This standard specifies the procedures and conditions to be followed for the validation by analysis and testing of: 1) the safety functions provided and 2) the category achieved of the safety-related parts of the control system in compliance with EN 954-1 (ISO 13849-1), using the design rationale provided by the designer.
EN 62061	Safety of machinery. Functional safety of safety-related electrical, electronic and programmable electronic control systems	The standard defines the safety requirements and guiding principles for the design of safety-related electrical/electronic/programmable parts of a control system.
EN ISO 13855 (replaces EN 999)	Safety of machinery - Positioning of safeguards with respect to the approach speeds of parts of the human body	This standard provides parameters based on values for hand/arm and approach speeds and the methodology to determine the minimum distances from specific sensing or actuating devices of protective equipment to a danger zone.

## EUROPEAN/INTERNATIONAL STANDARDS continued

Standard	Type	Description
EN 1088 and EN 1088/A1	Safety of machinery. Interlocking devices associated with guards. Principles for design and selection	This standard specifies principles for the design and selection— independent of the nature of the energy source— of interlocking devices associated with guards. It also provides requirements specifically intended for electrical interlocking devices. The standard covers the parts of guards which actuate interlocking devices.
EN 60204-1	Safety of machinery. Electrical equipment of machines. General requirements	This part of IEC 60204 applies to the application of electrical and electronic equipment and systems to machines not portable by hand while working, including a group of machines working together in a coordinated manner but excluding higher level systems aspects (i.e. communications between systems).

This document and any attachments may include suggested specifications, drawings, schematics and similar materials from ABB Inc. Use of such information and/or documentation by the recipient is subject to and conditioned upon your acceptance of the terms of the General Document Disclaimer which can be found at [www.jokabsafetyna.com](http://www.jokabsafetyna.com). Your acceptance of the terms of such General Document Disclaimer is conclusively presumed unless you notify ABB in writing of your disagreement with the terms of such Disclaimer immediately upon receipt of this document and you return to ABB all specifications, drawings, schematics and similar materials provided to you by ABB.

## Notes





*Compact  
Powerful  
Flexible  
Expandable  
Modular*



# Pluto Safety PLC

Simplify safety system design!  
Supervise all types of safety devices!  
Inputs for static/dynamic sensors!

Pluto Safety PLC Programmable Controller .....	2:2
Why should I use the Pluto Safety PLC? .....	2:4
Pluto Safety PLC facilitates the Design of your Safety Systems .....	2:6
Technical Information .....	2:7
Pluto Manager and IDFIX .....	2:8
Overview .....	2:8
Number of Edens that can be used with Pluto .....	2:9
Number of Tinas that can be used with Pluto .....	2:10
Pluto without a Safety Bus .....	2:11
Technical Data .....	2:12
I/O Overview .....	2:13
Input Connection and Reset Button .....	2:14
Pluto with a Safety Bus .....	2:15
Technical Data .....	2:16
I/O Overview .....	2:17
Certificates .....	2:18
Application Example .....	2:19
Pluto Gateway GATE-P2 .....	2:27
Pluto Gateway GATE-D2 .....	2:29
Pluto Gateway GATE-C2 .....	2:31
Pluto Gateway GATE-E2 .....	2:33
Pluto Safety Encoders .....	2:35
Pluto Manager .....	2:38
Connection Examples .....	2:40
Component List and Ordering Information .....	2:43

# Pluto Safety PLC Programmable Controller

## Networked Pluto

Pluto is an all-supervisor system in which the inputs and other information are shared via the databus. Several safety sensors can be connected to one input while still achieving the highest level of safety. There are also combined inputs and outputs that can be used, for example, for lamp push buttons where the input and output functions are used simultaneously. Pluto has inputs for all safety devices on the market, and the Pluto Manager software selects how each input shall respond. Pluto with a bus connection is available in several sizes:

## Pluto A20/B20

Up to 4,800 Dynamic Input Devices on Bus with 128 Individual Safe Outputs

## Pluto B46

Up to 12,480 Dynamic Input Devices on Bus with 192 Individual Safe Outputs

## Pluto AS-i

Up to 2,240 Dynamic Input Devices on Bus, 1,024 AS-i nodes with 128 Individual Safe Outputs

## Pluto B42 AS-i

Up to 11,200 Dynamic Input Devices on Bus, 1,024 AS-i nodes with 192 Individual Safe Outputs

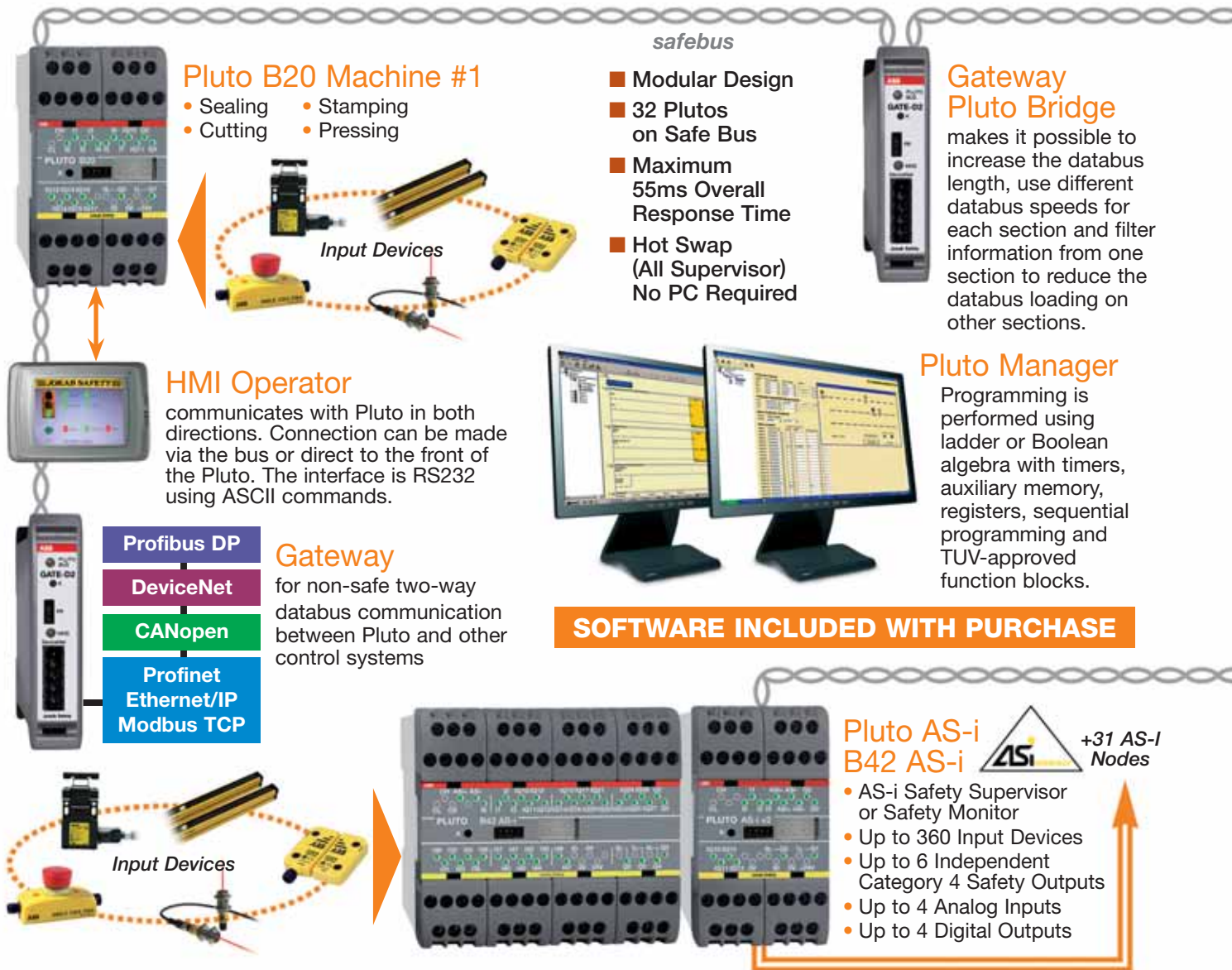

### Pluto B20 Machine #1

- Sealing
- Stamping
- Cutting
- Pressing

safebus

- Modular Design
- 32 Plutos on Safe Bus
- Maximum 55ms Overall Response Time
- Hot Swap (All Supervisor) No PC Required

### Gateway Pluto Bridge

makes it possible to increase the databus length, use different databus speeds for each section and filter information from one section to reduce the databus loading on other sections.

### HMI Operator

communicates with Pluto in both directions. Connection can be made via the bus or direct to the front of the Pluto. The interface is RS232 using ASCII commands.

### Gateway

for non-safe two-way databus communication between Pluto and other control systems

### Pluto Manager

Programming is performed using ladder or Boolean algebra with timers, auxiliary memory, registers, sequential programming and TUV-approved function blocks.

**SOFTWARE INCLUDED WITH PURCHASE**

### Pluto AS-i B42 AS-i +31 AS-i Nodes

- AS-i Safety Supervisor or Safety Monitor
- Up to 360 Input Devices
- Up to 6 Independent Category 4 Safety Outputs
- Up to 4 Analog Inputs
- Up to 4 Digital Outputs

Compact ■ Powerful ■ Flexible ■ Expandable ■ Modular

**Approvals**

- EN 954-1, Category 4
- EN ISO 13849-1, PL e
- EN 61496-1, Type 4
- EN 61508, SIL 3
- EN ISO 62061, SIL 3
- EN ISO 60204-1
- EN 50178
- EN ISO 574, Type IIc



**Pluto B46  
Machine #2**

- Bottling
- Packaging
- Welding
- Feeding



Input Devices



**Safety Encoders**

- Monitor Speed, Direction and Position
- Increase Production



Robot Machine #3

**Stand-Alone Pluto**

A single Pluto can be used as a fully programmable safety logic controller. Pluto without a bus connection is also available in two sizes:

**Pluto S20**

Up to 20 Standard I/Os or 150 Dynamic Devices

**Pluto S46**

Up to 46 Standard I/Os or 390 Dynamic Devices



**Pluto S20**

- Up to 150 Input Devices
- 4 Independent Category 4 Safety Outputs



Input Devices



**HMI  
Operator**



**Pluto S46**

- Up to 390 Input Devices
- 6 Independent Category 4 Safety Outputs



**BT51  
Expansion Relay**

Several expansion relays can be connected to a single Pluto safety output while retaining the safety level.

# Why should I use the Pluto Safety PLC?

## ...for simplifying the design!

Pluto is an “All-Supervisor” Safety PLC concept that simplifies the design of safety systems and achieves the highest safety (Category 4) according to EN 954-1/EN ISO 13849-1 and SIL 3 according to IEC/EN 61508.

The key difference between Pluto and conventional Safety PLCs is that there is no “supervisor-subordinate” relationship between the control units connected to the Safe Bus. All Plutos are “supervisor” units and can see each others’ inputs and outputs. Using this concept, each Pluto can make decisions about its own immediate safety environment.

This concept enables simple communication and easy alterations of the safety system. With the use of a “gateway” device, information from a Pluto network can be transferred to other bus systems thereby creating even larger systems. Gateway units are readily available for a number of different bus-systems — i.e. Profibus DP, DeviceNet, CANopen, Profinet, Ethernet/IP and Modbus TCP.

Pluto offers an economic solution for both a single machine and for large integrated machine systems. Of Pluto B20’s I/O, 8 can be configured as both inputs and outputs (sometimes even as inputs and outputs at the same time) and 4 are failsafe outputs independent of each other. 32 Plutos can be connected to a twisted pair safe bus system. This enables the amount of physical I/O connections to be expanded from 20 to 150 for the B20 family and 46 to 390 for the B46 family.

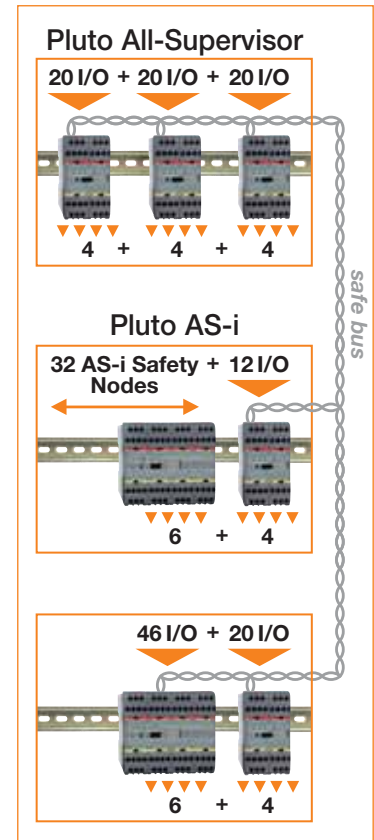
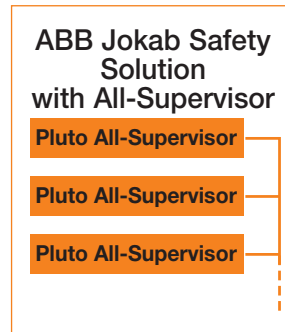
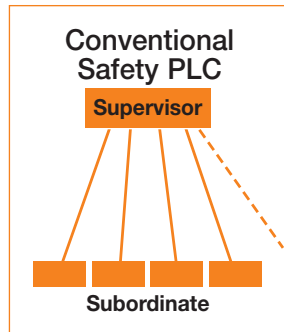

## ...to supervise safety devices!

Most safety devices on the market can be connected directly to the Pluto unit. When using dynamic sensors from ABB Jokab Safety, the number of I/O points can be significantly reduced. These sensors enable Category 4 in a dynamic pulse system. Up to 10 sensors can be connected in series to one input. For example, Eden non-contact sensors, SPOT light beams and Tina adapters (interfacing to emergency

stop push buttons, safety switches, etc.) can be connected in series to one input on the Pluto. Even mechanical switches can be connected to the “dynamic safety circuit using Jokab Safety’s Tina adapters. Up to 150 safety devices can be connected to one Pluto B20 and maintain Category 4 per EN 954-1 and ISO 13849-1 PL e.



Light Beams



Light Curtains and Grids



3-Position Devices



Gate Switches and Sensors

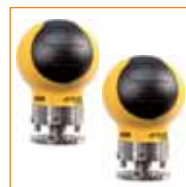

Two-Hand Controls



Strips, Mats and Bumpers



Emergency Stop Buttons

## ...to save on inputs!

Pluto has inputs for static and dynamic sensors. Several sensors can be connected to one dynamic input in accordance with Category 4, PL e, SIL 3.

### One input...

Dynamic signals: 1 to 10 sensors while maintaining Category 4, PL e, SIL 3.



### One input...

Dynamic signals: 1 to 10 doors with one Eden per door while maintaining Category 4, PL e, SIL 3.

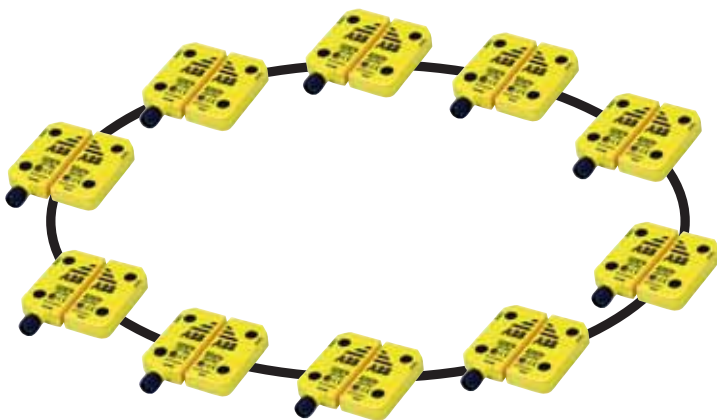

### Two inputs...

Static inputs: two mechanical switches per door while still maintaining Category 4, PL e, SIL 3.

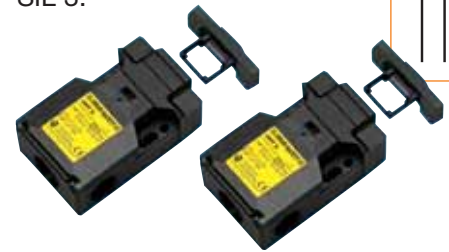

### One input...

I/O connections: can be used in three ways—inputs, outputs or both input and output at the same time (e.g. for a reset button with lamp indication).

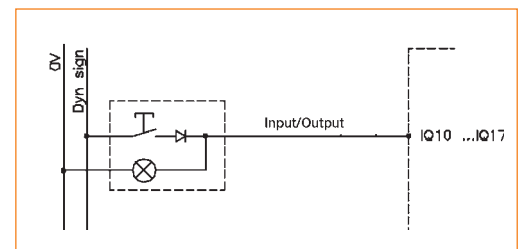

# Pluto Safety PLC facilitates the Design of your Safety Systems

Pluto is an All-Supervisor system for dynamic and static safety circuits where inputs and other information are shared over the bus. Multiple safety sensors can be connected to a single input and still achieve the highest level of safety. Pluto has inputs suited for every safety product on the market, and each input function is configured in the accompanying software, Pluto Manager.

Besides failsafe inputs (I) Pluto has a number of failsafe relay and transistor outputs (Q). On every Pluto unit there is also a possibility of using a number of terminals as failsafe inputs, non-failsafe outputs or both in and output simultaneously (IQ). The characteristics of the terminals are easily configured in Pluto Manager.

## Safety in Large and Small Systems

Pluto models without bus communication are stand alone units and are therefore perfectly suited for smaller systems that do not require communication with other Pluto units or gateways. Pluto models with bus communication can be connected to the Pluto bus where up to 32 Pluto units can interact and control large, as well as small, safety systems. The fact that Pluto is an All-Supervisor system means that each Pluto unit controls their outputs locally, while it is as easy to read other Pluto units' inputs as it is to read their own.

Specifically for Pluto A20 is that it is equipped with an analog input for current measurement, which can be used for e.g. monitoring of muting lamps.

Pluto is primarily designed to satisfy the requirements of EU Machinery Directive (2006/42/EG) regarding safety in control systems, but the system can also be used in other areas as in the process industry, boiler plants, etc. which have similar requirements.

## Regulations and Standards

The Pluto PLC is designed and approved in accordance with appropriate directives and standards. Examples of such are: EN 954-1/EN ISO 13849-1 Category 4, PL e, EN 61496-1 Type 4, EN 61508 SIL 3



## Control of

- Electrically controlled actuators such as contactors, valves, motors
- Indicators and buttons

## Applications

- Emergency Stops
- 3-Position Devices
- Interlocked Gates/Hatches
- Safety Mats
- Light Curtains
- Light Beams
- Two-Hand Devices
- Contact Strips
- Foot-Operated Switches
- Timing Functions
- Logic Functions
- Math Functions
- Speed Monitoring Functions
- Muting (bypassing)

## Features

- A Safety PLC for each part of a system
- Modular machine design
- Great flexibility
- Up to 10 sensors in series connected to one input
- Software Pluto Manager included with purchase
- Custom made safety bus

## Approvals

TÜV Rheinland  

## Pluto Technical Info

### Dynamic Signal

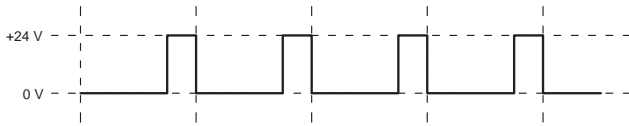

A dynamic signal makes it possible to achieve the highest level of safety with only one conductor. By transmitting a square wave and then evaluating the signal when it comes back to the controller you achieve the redundancy required. The signal is inverted once at each safety sensor (if the protection is OK) which makes it possible to detect short circuits across a sensor. When the signal switches between high (+24 V) and low (0V) it can be evaluated and tested about 200 times per second.

Pluto can generate three unique dynamic signals: A pulse, B pulse or C pulse. Short circuits between two different dynamic signals are detected whenever the signal that is created is different from the expected signal in Pluto. The kind of signal Pluto expects at the input terminal is determined in Pluto Manager (A, B or C pulse and if the signal should be inverted or not).

### Static Signal

Static signals (+24 V) can be connected to all inputs on Pluto. The kind of signal Pluto expects at the input terminal is determined in Pluto Manager. To achieve a two-channel structure according to EN ISO 13849-1 you need two inputs.

### OSSD-Signal

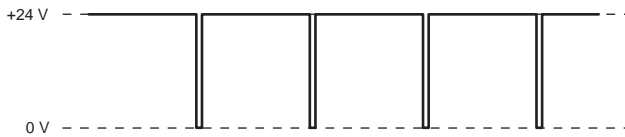

There are safety products with internal monitoring of dual OSSD signals (the device detects its own faults rather than Pluto doing this). From these devices, at least one of the two signals is connected to an I-input in Pluto, i.e. both signals must not be connected to the IQ-terminals. The terminal blocks are then configured in Pluto Manager to expect static inputs (OSSD signals are filtered internally in Pluto).

### IQ – Individual Failsafe Inputs and Non-Failsafe Outputs

The IQ terminals can be used either as individual failsafe input or non-failsafe output (e.g. for indicator light or status signal). The terminal blocks can also be used as both input and output simultaneously, which is useful for example for push buttons (input) with indicator light (output). This function is designed primarily for reset buttons to reduce the number of used terminal blocks on the controller.

### I - Individual Failsafe Inputs

All inputs are individually failsafe as each input is connected separately to both processors in Pluto. In order to maintain the redundancy required for two-channel structure and the highest level of safety, the dynamic signal must be used. When using static signals, two inputs must be used to achieve two-channel structure. The expected signal to the terminals blocks is determined in Pluto Manager (static or dynamic signal).

### Q - Individual Failsafe Outputs

All Q outputs are individually safe and are independently programmable. There are both relay outputs and transistor outputs.

### Transistor Outputs (-24 VDC)

The transistor outputs are just like the relay outputs—that is, individually safe and independently programmable. However, the transistor outputs are different from the relay outputs as the internal connection provides the nominal output voltage -24 VDC, which is primarily intended for controlling electromechanical components such as contactors and valves. As -24 VDC is a unique signal in the majority of electrical cabinets and the fact that the output is monitored by Pluto, short circuits with other potentials can be detected right away.

### Pluto-Bus

The Pluto-bus is a CAN-bus with its own safety protocol. The bus cable can be up to 600 m long at the minimum bus speed, and up to 150 m at 400 kb/s. The bus can be both extended and connected to other types of buses through gateways.

## Pluto Manager and IDFIX

### Pluto Manager

The Pluto Manager is a freeware for fast, easy and safe programming of the PLC program for Pluto. The programming language used is ladder, which is supplemented with TÜV-approved function blocks for many common features.

The software can also be used to configure Pluto's terminal blocks, e.g. to specify the IQ terminals that serve as inputs or outputs, and if the controller should expect a static or dynamic signal. Pluto Manager can be downloaded from [www.abb.com/lowvoltage](http://www.abb.com/lowvoltage), under Control Products – Safety Products – Programmable Safety Controllers – Pluto Manager.

### IDFIX

IDFIX is a identification circuit that is unique to each device on the Pluto bus. It includes an identification code and makes it possible to distribute a PLC program in the network. There are four different versions: R, RW, DATA and PROG. In addition to the identification code, DATA may also include safety codes from the AS-i nodes in an AS-i system. PROG includes the current PLC program and is used with single-Pluto for program distribution. IDFIX is connected between the input terminals ID and 0V.

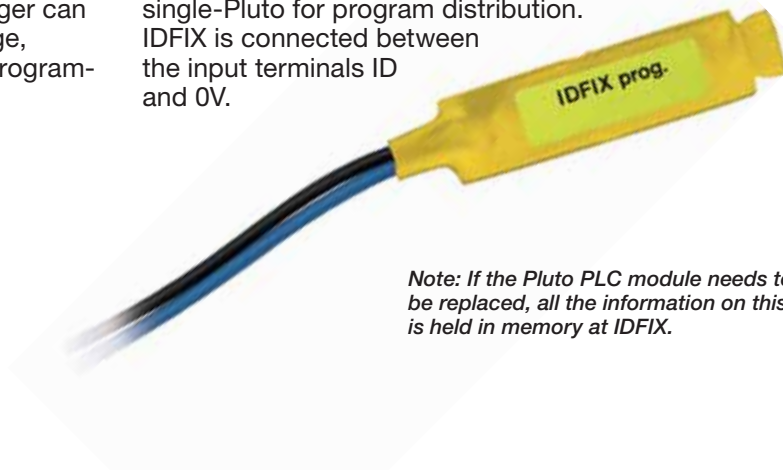

*Note: If the Pluto PLC module needs to be replaced, all the information on this is held in memory at IDFIX.*

### Overview Pluto Safety-PLC

Model	S20	S46	A20	B16	B20	B46	AS-i	B42 AS-i
Number of I/O	20	46	20	16	20	46	12	42
Failsafe inputs	8	24	8	8	8	24	4	20
Failsafe inputs or non-failsafe outputs	8	8	8	8	8	8	4	16
Analog inputs	1	3	1	1	1	3	4	3
Failsafe relay outputs	2	4	2	-	2	4	2	4
Failsafe transistor outputs	2	2	2	-	2	2	2	2
Pluto bus	-	-	●	●	●	●	●	●
Current monitoring	-	-	2	-	-	-	-	-
Dimensions (w x h x d) mm	45 x 84 x 118	90 x 84 x 118	45 x 84 x 118	45 x 84 x 118	45 x 84 x 118	90 x 84 x 118	45 x 84 x 118	90 x 84 x 118
Supply voltage	24VDC	24VDC	24VDC	24VDC	24VDC	24VDC	24VDC	24VDC



## Number of Edens that can be used with Pluto

The table below shows the number of Edens that can be connected to Pluto with the maximum voltage variation. The values have been established in a laboratory environment. The actual possible number of connected Edens may therefore differ from those given in the table. The values should be regarded as guidelines;

ABB Jokab Safety recommends a maximum of 10 Edens per Pluto input. The table was prepared according to measurements with connection example A. If connection example B and 0.34 mm<sup>2</sup> cable is used (with feed voltage from two directions), the values for 0.75 mm<sup>2</sup> in the tables are used.

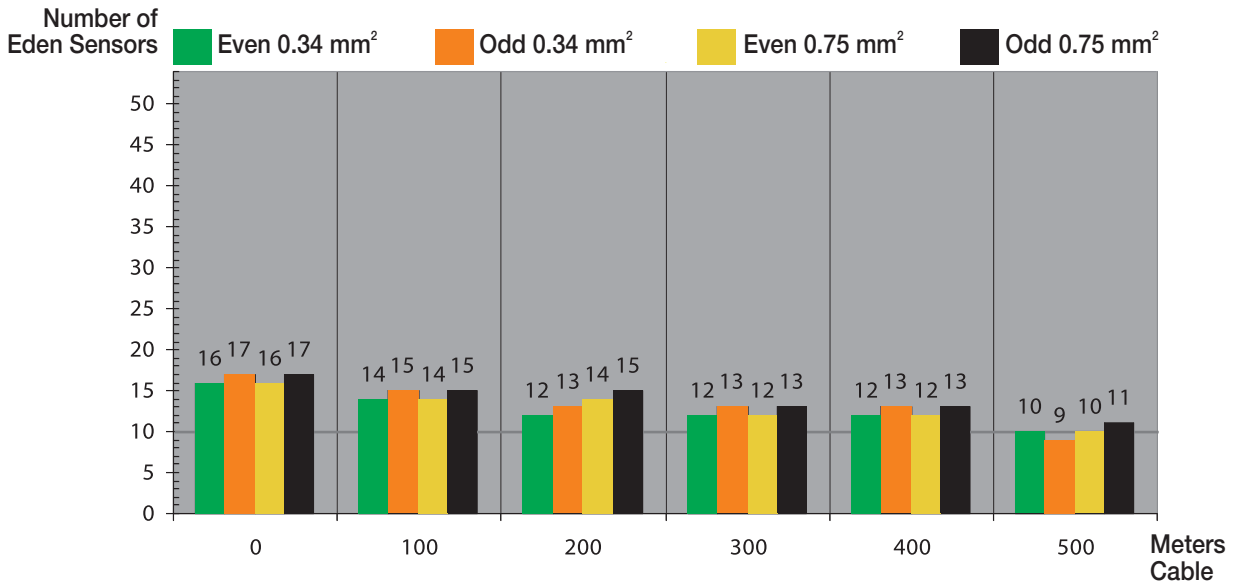
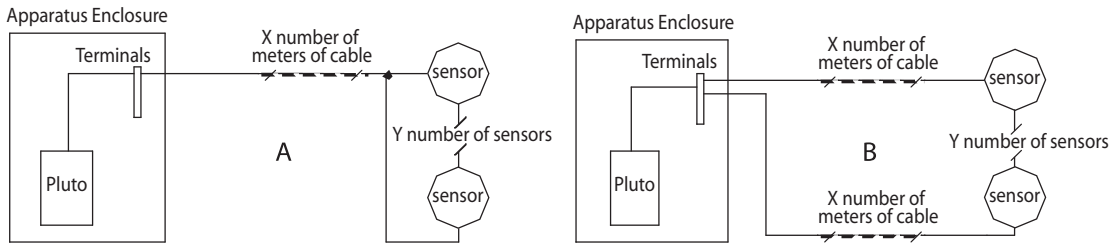

## Number of TinAs that can be used with Pluto

The following table shows the numbers of Tina-3A, Tina-6A, Tina-7A and SmileTina that can be connected to Pluto with the maximum voltage variation. The values have been established in a laboratory environment. The actual possible number of connected TinAs may therefore differ from those given in the table.

The values should be regarded as guidelines; ABB Jokab Safety recommends a maximum of 10 TinAs per Pluto input. The table was prepared according to measurements with connection example A. If connection example B and 0.34 mm<sup>2</sup> is used, the values for 0.75 mm<sup>2</sup> in the tables are used.

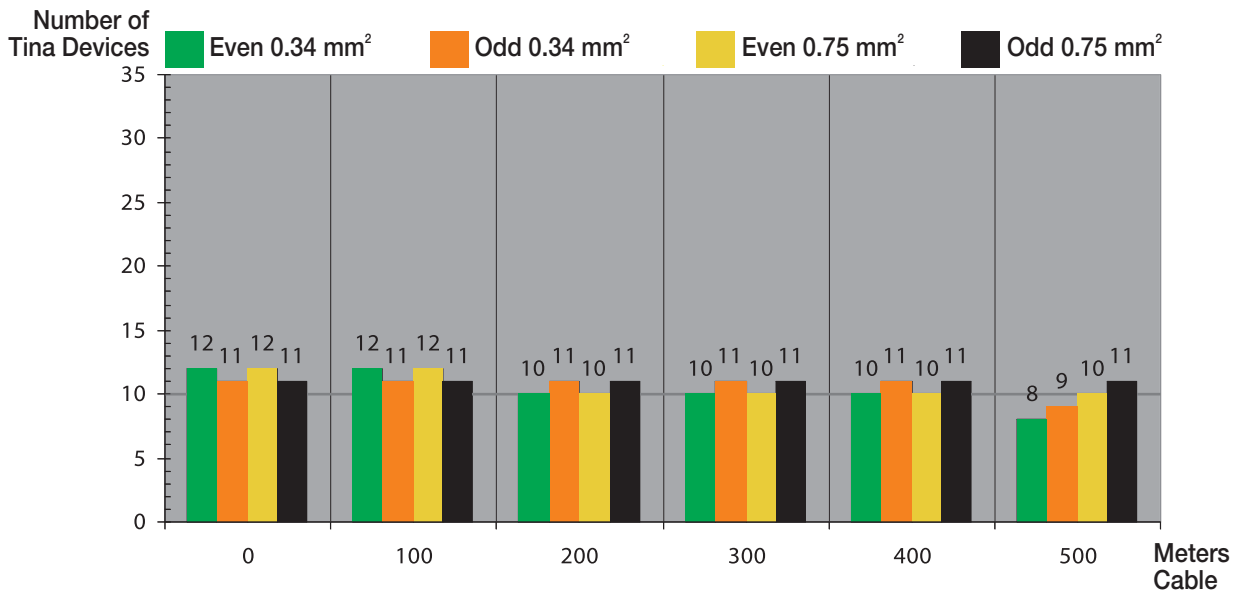
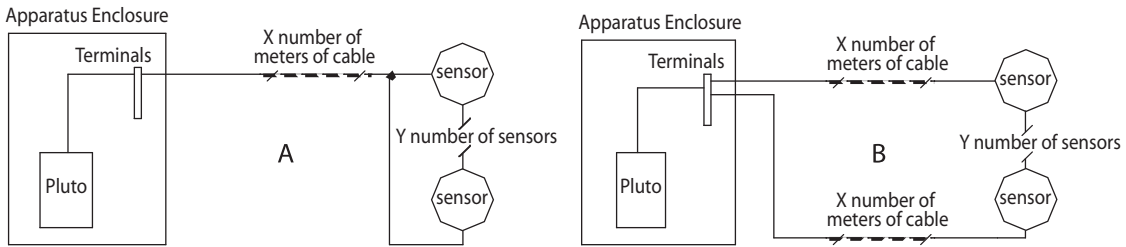

## Pluto without a Safety Bus

The Pluto S20 and Pluto S46 versions are safety PLCs that are designed for safety and protection products installed locally on a machine. With a wide range of connectivity options, a lot of protection is integrated into a PLC which in turn controls, for example, one or more safe outputs in a qualified manner without risking a dangerous situation.

Using an expansion relay, such as BT50, the number of safe outputs in Pluto can be expanded. The connection will then be made as shown in the figure.

If IDFIX PROG is used for single-Pluto, there is the option of copying a PLC program via the identification circuit over to Pluto without having to connect a computer.

*Single Pluto controls and monitors safety for local systems—large systems, as well as small systems.*



20/46 I/O

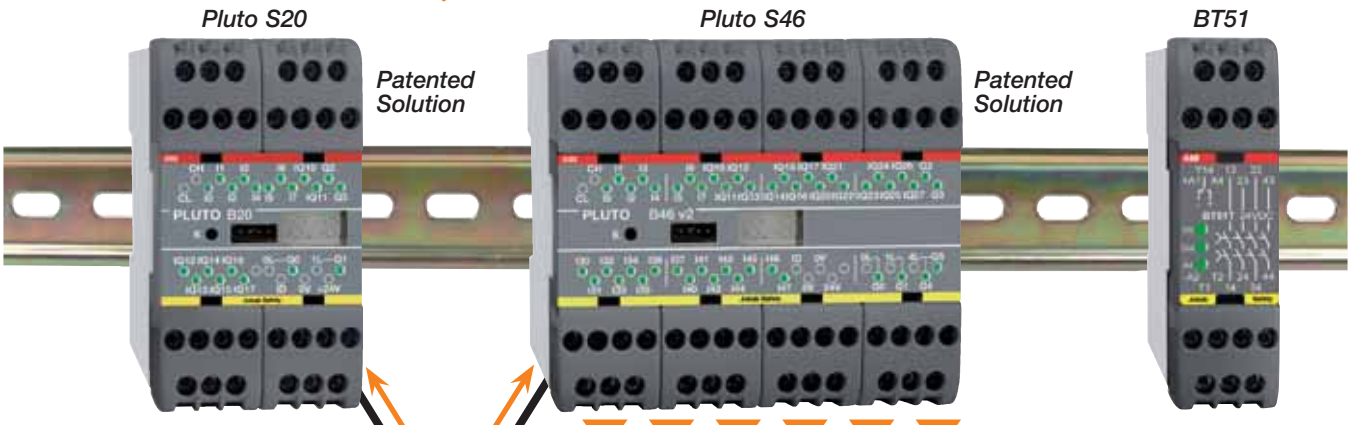

**HMI**  
A HMI-terminal is easy to connect to the Pluto through the programming port.

**Contactor Expansion**  
Several expansion relays can be connected to a single Pluto safety output while retaining the safety level.

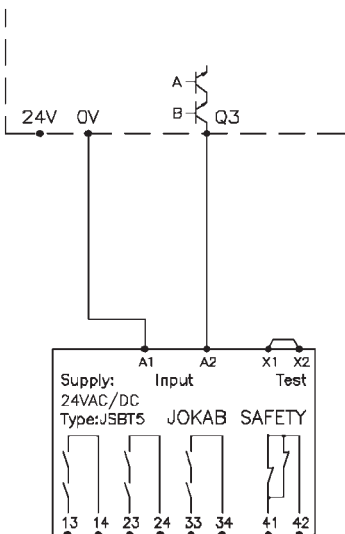

**Pluto Manager**  
A free-of-charge software is available on our website. See page 2:38 for more information.

## Pluto without a Safety Bus General Technical Data

Manufacturer	ABB AB/Jokab Safety, Sweden	Non-failsafe outputs Q Type	Transistor +24V, PNP "open collector" also configurable as failsafe inputs
Color	Grey	Max. current/output	800 mA
Operating voltage	24V DC $\pm 15\%$	Temperature	Ambient temperature Storage and transport
Installation	35 mm DIN rail		-10°C to +50°C -25°C to +55°C
Electrical insulation	Category II in accordance with IEC 61010-1	Response times	
Level of safety	Cat. 4	Dyn. A or static input to relay output	<20.5 ms + program exec. time
EN 954-1	PL e/cat. 4	Dyn. A or static input to transistor output	<16.5 ms + program exec. time
EN ISO 13849-1	SIL 3	Dyn. B or Dyn. C input to relay output	<23 ms + program exec. time
EN 61508	SIL 3	Dyn. B or Dyn. C input to transistor output	<19 ms + program exec. time
EN 62061	SIL 3	Software setting "NoFit"	5 ms shorter response time on I & IQ inputs
PFH <sub>d</sub>		Additional response times	
Relay output	2.00×10 <sup>-9</sup>	Databus between Pluto units	10 ms
Transistor output	1.50×10 <sup>-9</sup>	Databus between Pluto units on error	10–40 ms
Type	+24 V (for PNP sensors), IQ also configurable as non-failsafe outputs	Classification	
Current at 24 V	5.1 mA	Enclosure	IP 40, IEC 60 529
Max. overvoltage	27 V continuous	Connection terminals	IP 20, IEC 60 529
Safe outputs Q	Transistor, -24VDC, 800 mA		
Q2–Q3	Supply voltage - 1.5 V at 800 mA		
Output voltage tolerance	Relay outputs		
Q0, Q1, (Q4, 5)	AC-1: 250 V/1.5 A AC-15: 250 V/1.5 A DC-1: 50 V/1.5 A DC-13: 24 V/1.5 A		

## Pluto without a Safety Bus Type-Specific Technical Data

The terminal blocks are detachable without needing to disconnect the wiring. The units are assembled with a gap of at least 5 mm.

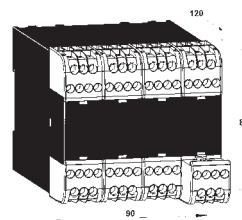
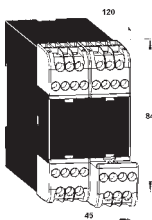

	Pluto S20 20 I/O Non-Pluto Safety bus	Pluto S46 46 I/O Non-Pluto Safety bus
Ordering information	see page 2:43	see page 2:43
Failsafe inputs	8 (I0..I7)	24 (I0..I7, I30..37, I40..I47)
Failsafe inputs or non-failsafe outputs	8 (IQ10..IQ17) Max total load 2.5 A	16 (IQ10..IQ17) (IQ20..IQ27) Max. total load 2A (per bank)
Analog inputs	1 (I5) 0..27V	3 (I5) 0..27 V
Failsafe relay outputs	2 (Q0..Q1)	4 (Q0..Q1 & Q4..Q5)
Failsafe transistor outputs	2 (Q2..Q3)	2 (Q2..Q3)
Current monitoring	–	–
Pluto Safety bus	–	–
Own current consumption	100...300 mA	100...500 mA
Recommended external fuse	6 A	10A
Dimensions (w x h x d)	45 x 84 x 118 mm	90 x 84 x 118 mm

## I/O Overview - Pluto without a Safety Bus

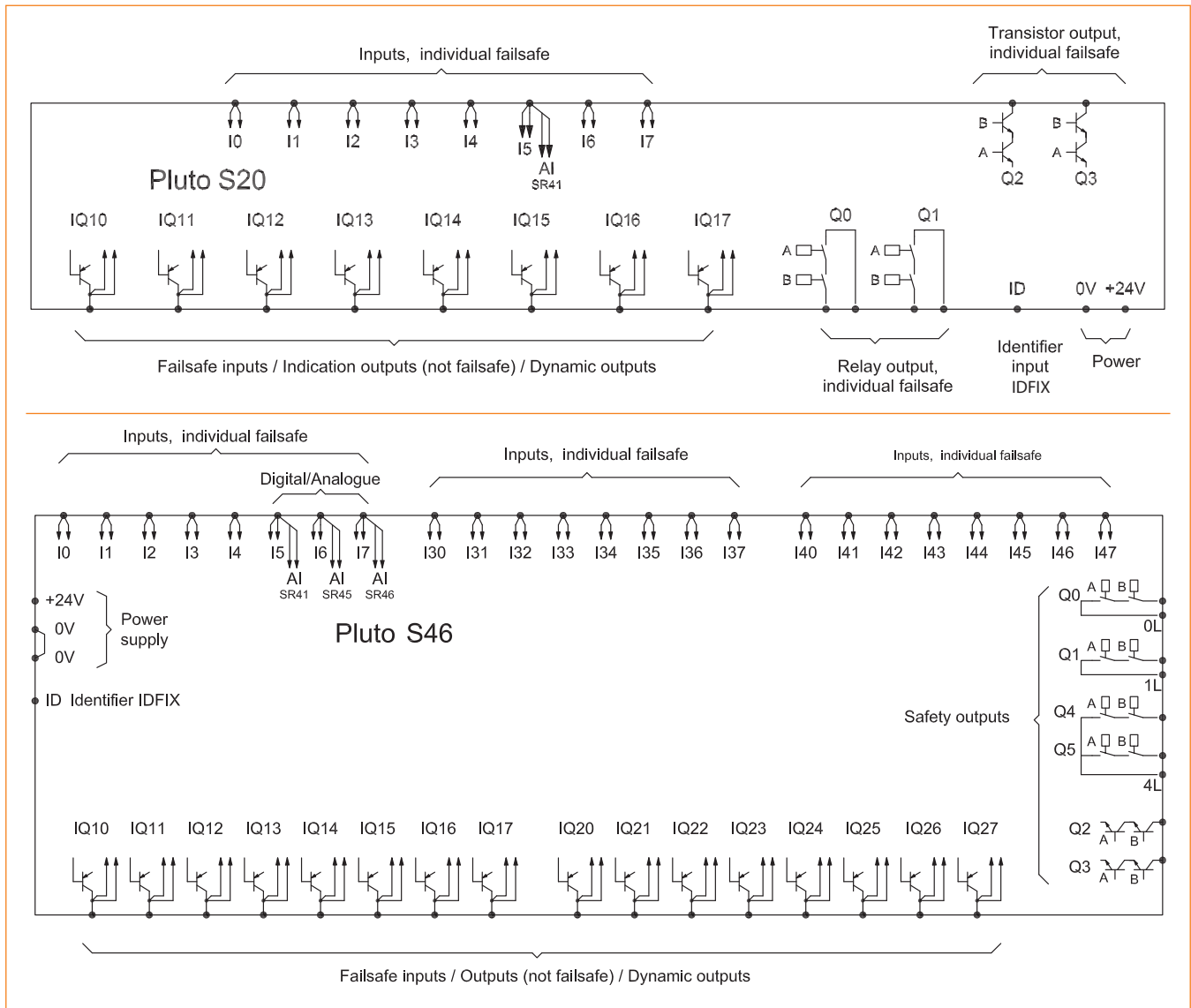

**ID:** Connection for identifier, which has a unique ID number that can be read by the system.

**I..** Safety inputs (24 VDC) that are individually secure. This means that the highest level of safety can be achieved with only one input if ABB Jokab Safety dynamic safety components are used. Otherwise two inputs are required for each safety function.

**IQ..** I/O that can be used for safety inputs or signal outputs, e.g. to indicate or control functions that are not safety-related. For IQ.. as safety inputs, refer to I..

**Q0, Q1:** Failsafe relay outputs that are individually failsafe and individually programmable.

**Q2, Q3:** Failsafe transistor outputs (-24 VDC) that are individually failsafe and individually programmable. Intended for electro-mechanical components such as contactors and valves.

**Q4, Q5:** Failsafe relay outputs with common potential that are individually failsafe and individually programmable.

## Input Connection

The system offers solutions for both single and two-channel safety devices. In order to monitor wiring short-circuits it is possible to use up to three different dynamic signals and static voltage (+24 V) to supply the inputs. The inputs are then programmed to only accept one of the signal types.

In a two-channel system both channels will be measured, using two different signals. The system will therefore be able to detect a short-circuit between the channels.

In a single channel system the dynamic signal is modified at each sensor. A short-circuit between the input and the output of the sensor will be detected at the Pluto input. PL e according to EN ISO 13849-1 can thus be achieved by using only one channel and one input.

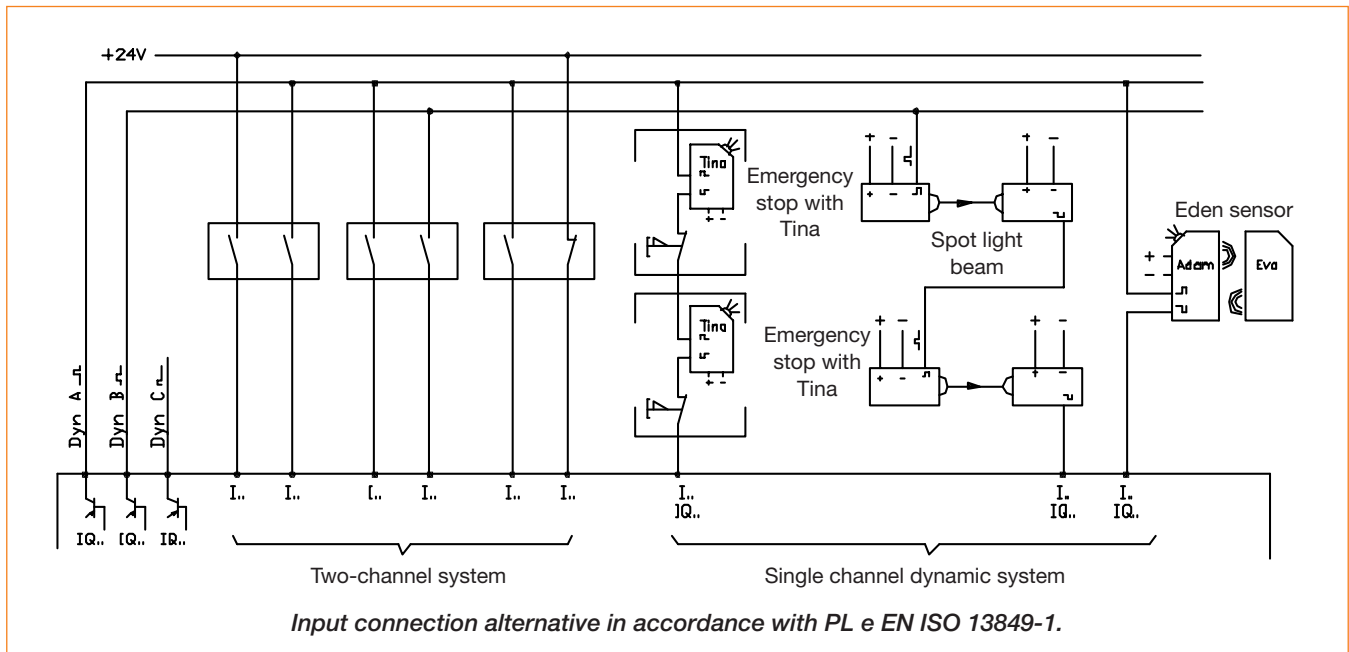

## Reset Button that uses the combined Input and Output Facility

Both a lamp and a pushbutton can be connected to the same terminal. This function is for resetting safety devices and to reduce the number of I/Os used.

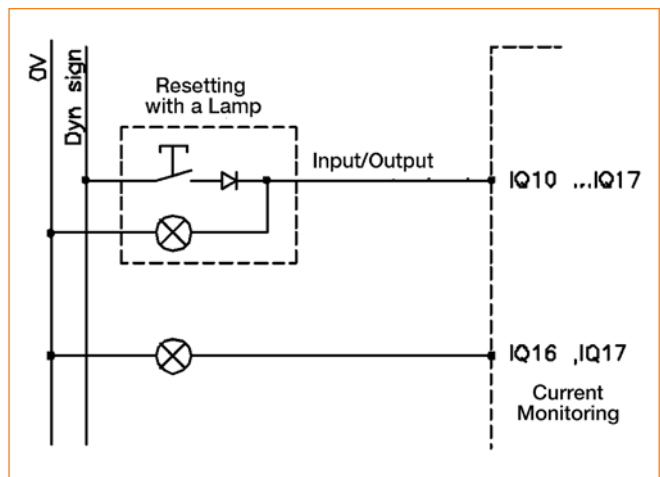

## Pluto with a Safety Bus

Pluto versions with a safety bus have the same properties as single-Plutos without bus communication. With the help of the Pluto-bus, networks can be created with multiple Plutos in interaction. Gateways can be connected to the Pluto bus for communication with other systems. The gateway models GATE D2 and C2 can also be used as an extension of the bus cable to extend the Pluto network. The fact that Pluto is an

All-Supervisor system means that each Pluto device controls its outputs locally, while it is as easy to read other Pluto units' inputs as it is to read their own. It is also easy to both read and write to global memory locations available across the Pluto bus. The PLC program is created using the Pluto Manager freeware and is distributed to all Pluto units. You can also connect speed and position sensors via the Pluto bus.

*Pluto models with a safety bus control and monitor safety for dispersed systems—large systems, as well as small systems.*



20/46 I/O

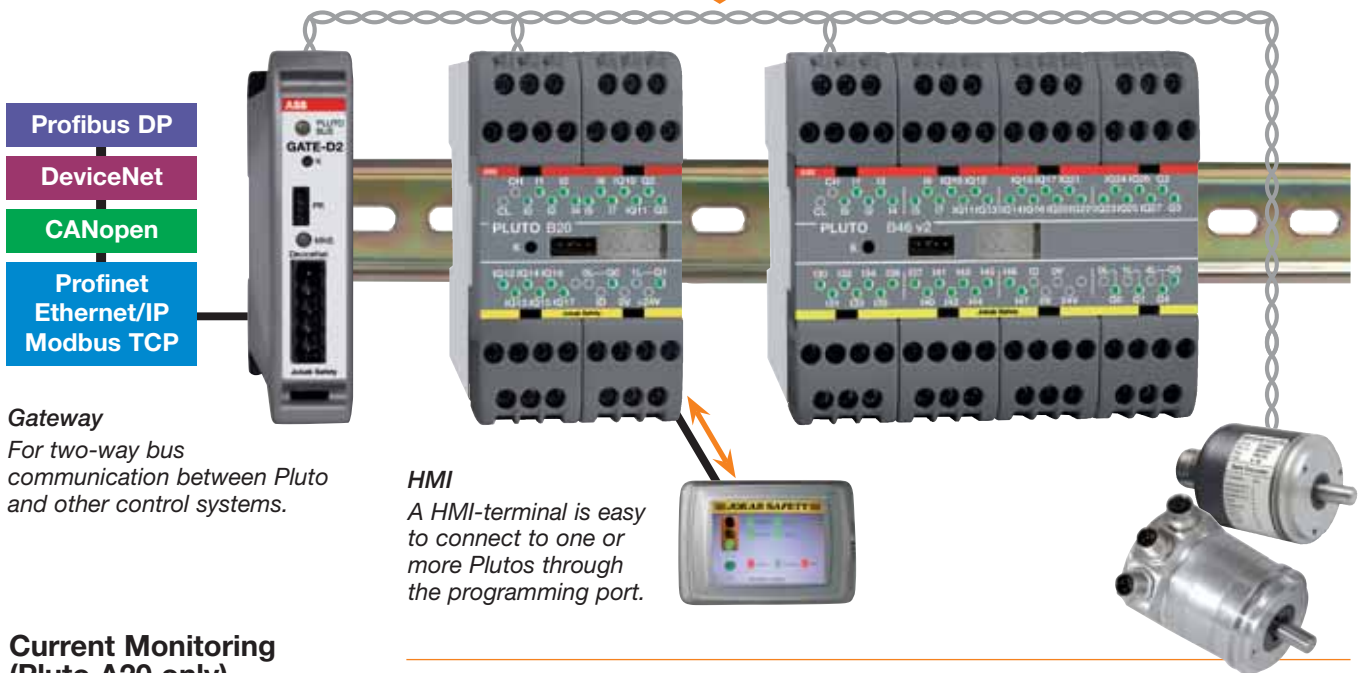

**Gateway**  
For two-way bus communication between Pluto and other control systems.

**HMI**  
A HMI-terminal is easy to connect to one or more Plutos through the programming port.

### Current Monitoring (Pluto A20 only)

Pluto A20 can monitor the current through the IQ16 and IQ17 outputs. The function is designed for, but not limited to, ensuring that the muting lamps are working. The hardware for current monitoring is not designed with individual redundancy, which means that the function must be used dynamically if it is to be used in a safety function. This means that the current must be read and evaluated both when the output is enabled and disabled.

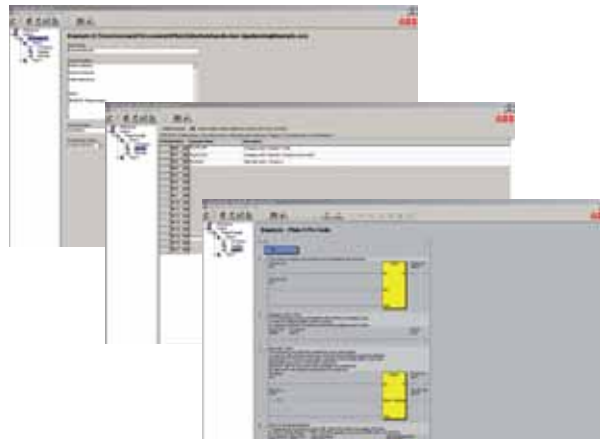

**Pluto Manager**  
A free-of-charge software is available on our website. See page 2:38 for more information.

## Pluto with a Safety Bus General Technical Data

<b>Manufacturer</b>	ABB AB/Jokab Safety, Sweden	<b>Temperature</b>	
<b>Color</b>	Grey	Ambient temperature	-10°C to +50°C
<b>Operating voltage</b>	24V DC ±15%	Storage and transport	-25°C to +55°C
<b>Installation</b>	35 mm DIN rail	<b>Pluto Safety bus</b>	
<b>Electrical insulation</b>	Category II in accordance with IEC 61010-1	Max number of Pluto units on the databus	32
<b>Safety level</b> EN 954-1 EN ISO 13849-1 EN 61508 EN 62061	Cat. 4 PL e/cat. 4 SIL 3 SIL 3	Databus type	CAN
<b>PFH<sub>d</sub></b> Relay output Transistor output	2.00×10 <sup>-9</sup> 1.50×10 <sup>-9</sup>	Databus speeds	100, 125, 200, 250, 400, 500, 800, 1000 kb/s
<b>Failsafe inputs I &amp; IQ</b> Type	+24 V (for PNP sensors), IQ also configurable as non-failsafe outputs	Databus cable length	Up to 600 m, 150 m at 400 kb/s
Current at 24 V Max. overvoltage	5.1 mA 27 V continuous	<b>Response times</b> Dyn. A or static input to relay output Dyn. A or static input to transistor output Dyn. B or Dyn. C input to relay output Dyn. B or Dyn. C input to transistor output Software setting "NoFit"	<20.5 ms + program exec. time <16.5 ms + program exec. time <23 ms + program exec. time <19 ms + program exec. time 5 ms shorter response time on I & IQ inputs
<b>Safe outputs Q</b> Q2-Q3 Output voltage tolerance Q0, Q1, (Q4, 5)	Transistor, -24VDC, 800 mA Supply voltage - 1.5 V at 800 mA Relay outputs AC-1: 250 V/1.5 A AC-15: 250 V/1.5 A DC-1: 50 V/1.5 A DC-13: 24 V/1.5 A	<b>Additional Response times</b> Databus between Pluto units Databus between Pluto units on error	10 ms 10-40 ms
<b>Non-failsafe outputs Q</b> Type Max. current/output	Transistor +24V, PNP "open collector" also configurable as failsafe inputs 800 mA	<b>Classification</b> Enclosure Connection terminals	IP 40, IEC 60 529 IP 20, IEC 60 529

## Pluto with a Safety Bus Type-Specific Technical Data

The terminal blocks are detachable without needing to disconnect the wiring. The units are assembled with a gap of at least 5 mm.

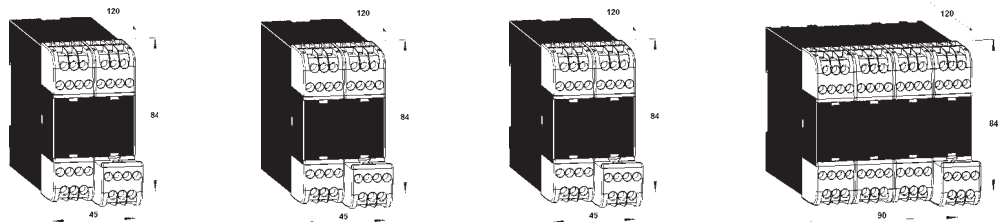

	Pluto A20 20 I/O Current monitoring	Pluto B16 16 I/O Non-failsafe outputs	Pluto B20 20 I/O	Pluto B46 46 I/O
<b>Ordering information</b>	see page 2:43	see page 2:43	see page 2:43	see page 2:43
<b>Failsafe inputs</b>	8 (I0..I7)	8 (I0..I7)	8 (I0..I7)	24 (I0..I7, I30..I37, I40..I47)
<b>Failsafe inputs or non-failsafe outputs</b>	8 (IQ10..IQ17) Max total load 2.5 A	8 (IQ10..IQ17) Max total load 2.5 A	8 (IQ10..IQ17) Max total load 2.5 A	16 (IQ10..IQ17) (IQ20..IQ27) Max. total load 2A (per bank)
<b>Analog inputs</b>	1 (I5) 0..27V	1 (I5) 0..27V	1 (I5) 0..27V	3 (I5) 0..27 V
<b>Failsafe relay outputs</b>	2 (Q0..Q1)	-	2 (Q0..Q1)	4 (Q0..Q1 & Q4..Q5)
<b>Failsafe transistor outputs</b>	2 (Q2..Q3)	-	2 (Q2..Q3)	2 (Q2..Q3)
<b>Current monitoring</b>	2(IQ16,IQ17)0-1.0A±10%	-	-	-
<b>Pluto Safety bus</b>	•	•	•	•
<b>Own current consumption</b>	100...300 mA	100...300 mA	100...300 mA	100...500 mA
<b>Recommended external fuse</b>	6 A	6 A	6 A	10A
<b>Dimensions (w x h x d)</b>	45 x 84 x 118 mm	45 x 84 x 118 mm	45 x 84 x 118 mm	90 x 84 x 118 mm



## I/O Overview - Pluto with a Safety Bus

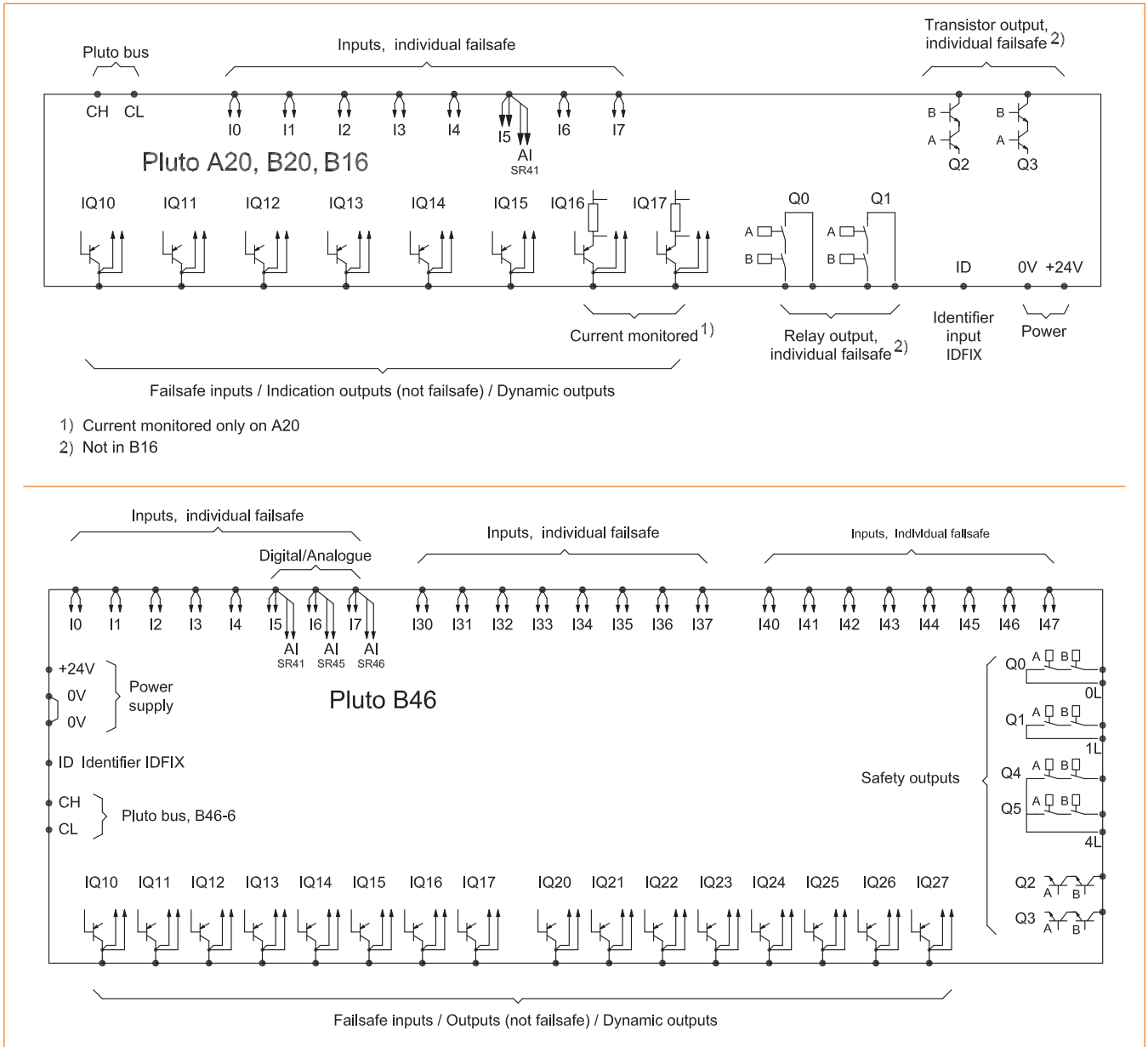

**ID:** Connection for identifier, which has a unique ID number that can be read by the system.

**I..:** Safety inputs (24 VDC) that are individually secure. This means that the highest level of safety can be achieved with only one input if ABB Jokab Safety dynamic safety components are used. Otherwise two inputs are required for each safety function.

**IQ..:** I/O that can be used for safety inputs or signal outputs, e.g. to indicate or control functions that are not safety-related. For IQ.. as safety inputs, refer to I..

**Q0, Q1:** Failsafe relay outputs that are individually failsafe and individually programmable.

**Q2, Q3:** Failsafe transistor outputs (-24 VDC) that are individually failsafe and individually programmable. Intended for electro-mechanical components such as contactors and valves.

**Q4, Q5:** Failsafe relay outputs with common potential that are individually failsafe and individually programmable.

# Certificates

**TÜVRheinland®**

**ZERTIFIKAT**      **EC Type-Examination Certificate**  
**CERTIFICATE**      **Reg.-No.: 01/205/5066/10**

<b>Product tested</b>	Logic unit to ensure safety functions Safety PLC	<b>Certificate holder</b>	ABB AB Jokab Safety Svevägen 3 213 76 Malmö Sweden
<b>Type designation</b>	Plato	<b>Manufacturer</b>	see certificate holder
<b>Codes and standards forming the basis of testing</b>	EN ISO 13849-1:2008 + AC:2009 EN 60201:2005 IEC 61508 Parts 1, 3, 7:1998 / 2000 EN 60204-1:2006 + A1:2009 (if extracts)	EN 60178:1997 EN 61496-1:2002 + A1:2002 (if extracts) EN 574:1988 + A1:2002 (if extracts)	
<b>Intended application</b>	Safety related programmable electronic system for machinery and process industry applications.  The Plato PLC complies with the requirements of the relevant standards (Cat. 4 / PL a acc. to EN ISO 13849-1, SIL CL. 3 acc. to EN 60201 / IEC 61508, Type DC of EN 574, Type A of EN 61496-1) and can be used in applications up to Cat. 4 / PL a acc. to EN ISO 13849-1 and SIL CL. 3 acc. to EN 60201 / IEC 61508.		
<b>Specific requirements</b>	The current "Version Release List" as well as the conditions defined in the Programming Manual, Safety Manual and the Operating Instructions must be consulted.		
It is confirmed, that the product under test complies with the requirements for machines defined in Annex 1 of the EC Directive 2006/42/EC.			
This certificate is valid until 2015-11-18.			



**Functional Safety  
Type Approval**

**FS**

The test report no. 8888 107 0010 dated 2010-11-19 is an integral part of this certificate.

The holder of a valid license certificate for the product tested is authorized to affix the **FS** mark where appropriate to products, which are identical with the original system.



**E. J.**

Chief Eng. Elshard Frayo

TÜV RHEINLAND CERTIFICATE NO. 01/205/5066/10

**TUV NORD**

**EG-Baumusterprüfbescheinigung**  
 EC type-examination certificate

**Register-Nr.**  
 44 205 11 20092 000

<b>Bezeichnung des Auftragsgebers</b> Customer's address	<b>Auftraggeber</b> Date of order	<b>Abnehmer</b> The addressee	<b>Prüfnummer</b> Test report no.
	16.11.2010	ABB AB Jokab Safety Verkehrsweg 11 424 39 Kungälv Sweden	11 200 20002 000
<b>Name und Anschrift des Auftragnehmers</b>	<b>ABB AB</b> Jokab Safety Verkehrsweg 11 424 39 Kungälv Sweden		<b>Customer's name and address</b>
Es wird bestätigt, dass die Anforderungen des Antrages 1 der Maschinenrichtlinie 2006/42/EG als eine Grundlage für die EG-Normüberprüfung. The product described herein meets the requirements of Annex 1 of the Directive 2006/42/EC as a basis for the EC Declaration of conformity.			
<b>Geprüft nach</b>	<b>Normen/Standards</b> 2006/42/EG Machinery Directive 2006/42/EC	<b>Technische Beschreibung</b>	
	EN 61508:2000 EN 60201:2005 EN 60178:1997 + A1:2002 EN 574:1988 + A1:2002 for UR42 ET class EN 61496		
<b>Bestimmendes Merkmal</b> Characteristics Article 1)	Safety input value for low speed "M3 Safety at Work"	<b>Charakteristika des Produkts</b> (Details see article 1)	
<b>Typenbezeichnung</b>	<b>UR42</b>	<b>Type description</b>	
<b>Artikel-Nr.</b>	Artikel Anlage 1 see annex 1	<b>Article</b>	
<b>Bezeichnung</b>	EN 61508:2000-06, SIL = 3 (PL) a EN 60201:2005, PL	<b>Article</b>	
Bitte beachten Sie auch die unterliegenden Mitteilungen. Please also pay attention to the information pages attached.			
<b>TUV NORD CERT</b> Zweig Sachverständigenbüro / Technisches Büro Maschinen- / Prüftechnik Bremerhaven 10001 			<b>Stellung des / der</b> 16.11.2010  <b>Wahrscheinl. Datum</b> 16.11.2010

Legende: 01 = 01/205/5066/10; 10 = 10/2009/20002/000; 11 = 11/2000/20002/000; 20 = 20/2000/20002/000

**CSA INTERNATIONAL**

**Certificate of Compliance**

Certificate: 1780124      Master Contract: 103438  
 Project: 190310      Date Issued: 20080107

Issued to: Jokab Safety AB  
 Besvägen 3  
 Malmö, 213 76  
 Sweden

*The products listed below are eligible to bear the CSA Mark shown with adjacent indicators 'C' and 'US'*



Issued by: David Dupont, T.P.

Authorized by: Helene Vallarand,  
Operations Manager



**PRODUCTS**

CLASS 2222 E1 - PROCESS CONTROL EQUIPMENT - Certified to US Standards  
 CLASS 2222 A3 - PROCESS CONTROL EQUIPMENT - Compliance  
 CLASS 2222 E2 - PROCESS CONTROL EQUIPMENT - Certified to US Standards  
 CLASS 4214 E1 - INDUSTRIAL CONTROL EQUIPMENT - Measurement Apparatus

Component type: Programmable Logic Controller, programmable (unidirectional) inverter, Module PLUTO A31, PLUTO B31, PLUTO C31, PLUTO A16, PLUTO B16, PLUTO B46-6, PLUTO 346-6 and PLUTO A5-5, rated input 24Vdc, 5A (max), rated output: 24Vdc, 800mA; 2.5A max total load of outputs (R10, R17) (R20-27) and 250V ac, 1.5A (R8-R9-Q1), 2.5Vdc, 800mA (R2-Q3), R46, R78 terminals.

The 'C' and 'US' indicators adjacent to the CSA Mark signify that the product has been certified to the applicable U.S. and/or U.S. Standards. The 'C' and 'US' marks and the 'C' and 'US' indicators on the product indicate compliance with the 'C' and 'US' indicators. The 'C' and 'US' indicators are not required on the product if the product is certified to the applicable U.S. and/or U.S. Standards. The 'C' and 'US' indicators are not required on the product if the product is certified to the applicable U.S. and/or U.S. Standards.

2008-01-07 10:30:00

## Application Example

### Robot Cell with Pluto



#### Description

The example describes a processing machine served by a robot. The machine safety system consists of one (Pluto 1) to which all protection has been connected. The robot has been equipped with a (Pluto 0) to which the cell protection has been connected. The Pluto for the machine has been connected via a databus cable to the robot's Pluto so that common functions, such as emergency stop, can be used by the whole cell.

#### Function

Emergency stop takes priority and will stop both the machine and the robot. The machine hatch acts as the zone divider, when the hatch is closed the machine forms one zone and the robot another zone. When the machine hatch is open, both the machine and the robot belong to the same zone. If the door is opened when the machine hatch is open, the machine and the robot will both stop, but if the machine hatch is closed, only the robot will be stopped.

After the door has been opened, the system must be reset by means of the reset button on the outside of the door.

**Note:** *The cell operating cycle must not start immediately on resetting the emergency stop or the door.*

# Electrical Connections

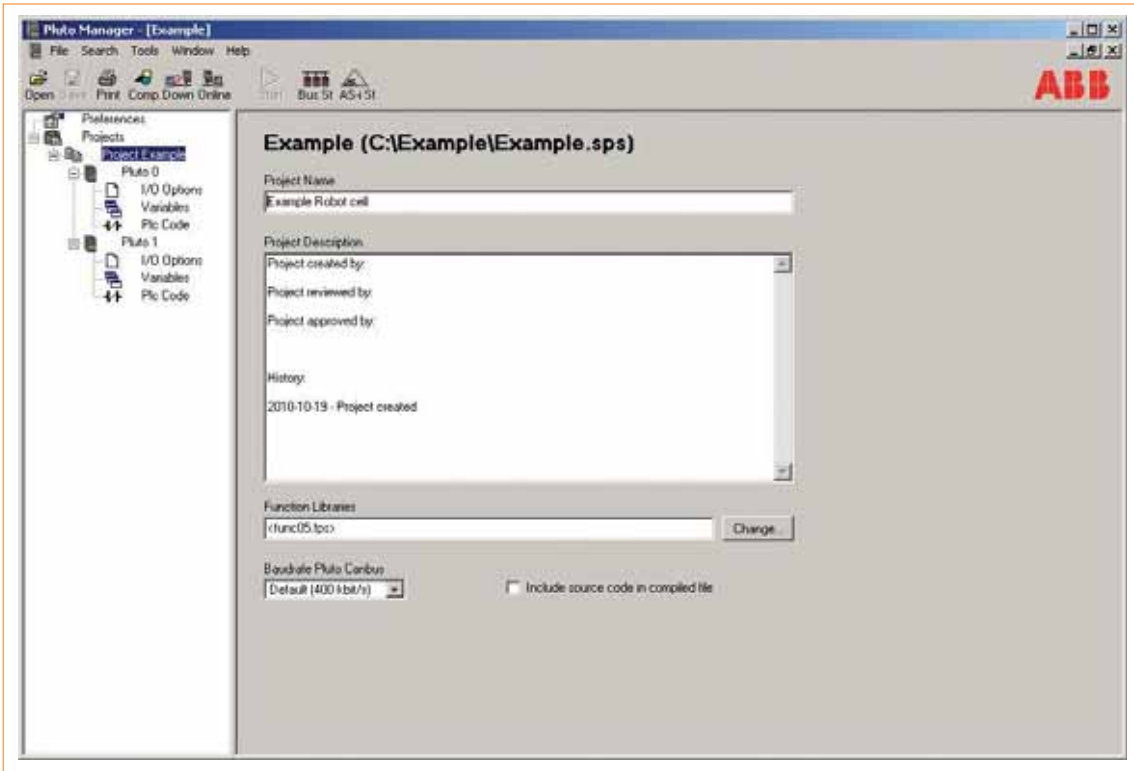
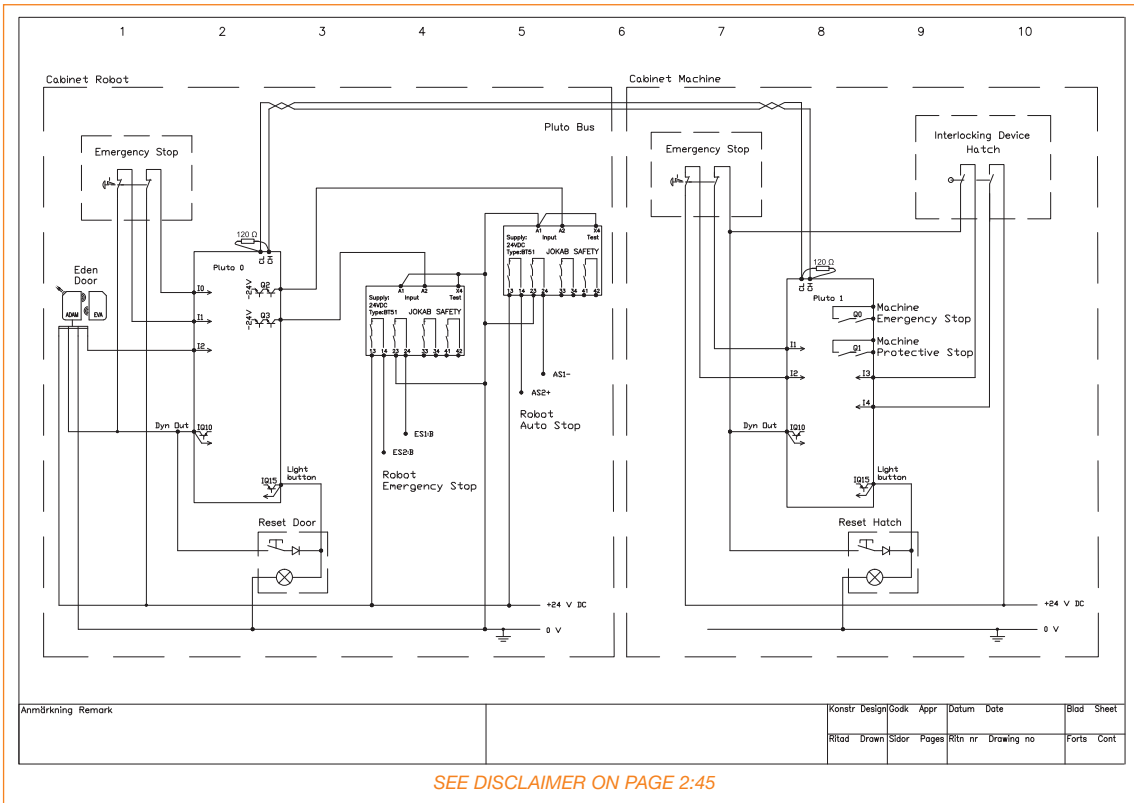

## Pluto 0 Settings – Robot Cabinet

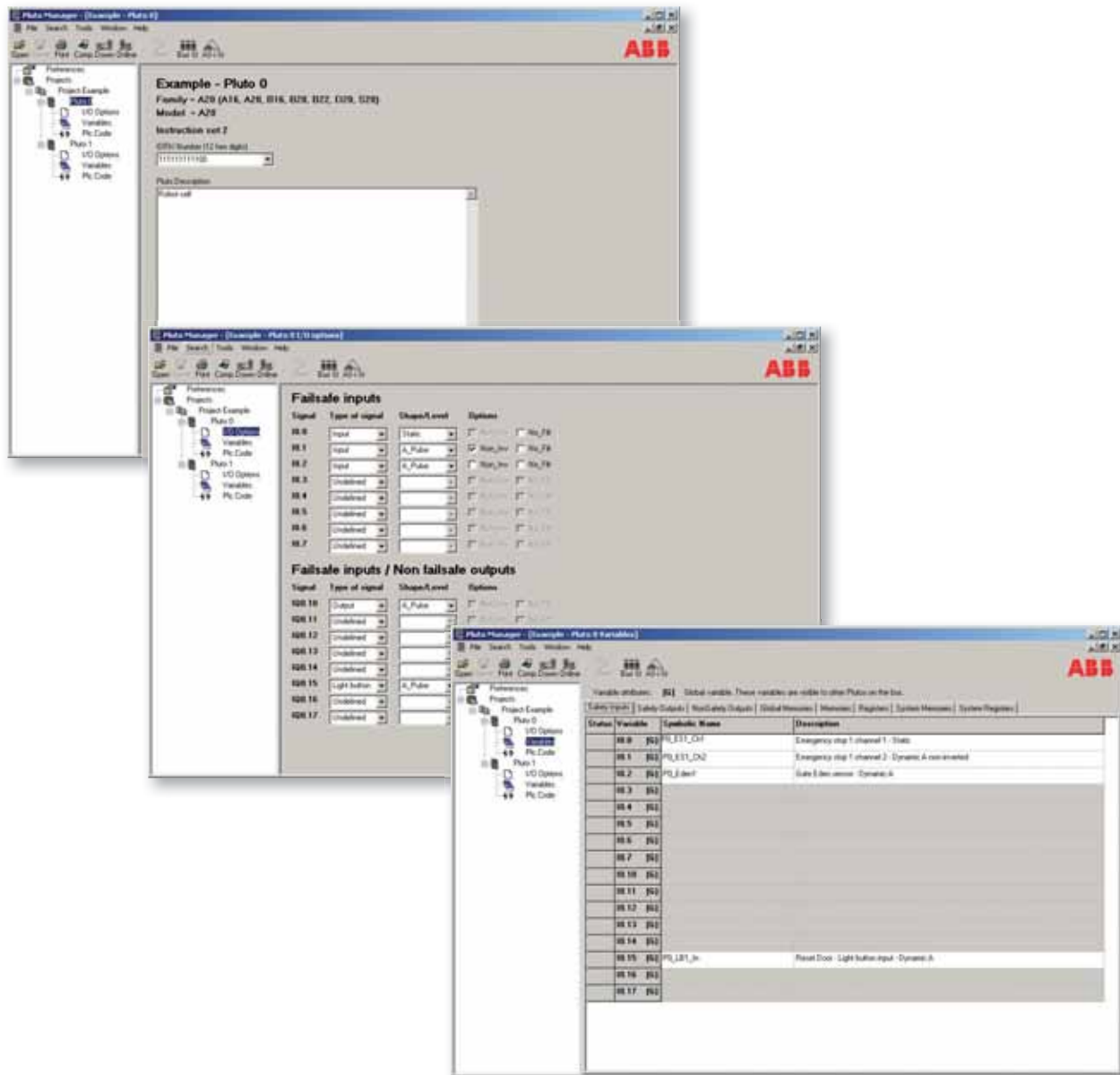

### Pluto 0

- IO.0=P0\_ES1\_Ch1:** Emergency stop 1 channel 1 - Static
- IO.1=P0\_ES1\_Ch2:** Emergency stop 1 channel 2 - Dynamic A non-inverted
- IO.2=P0\_Eden1:** Door Eden sensor - Dynamic A
- IO.15=P0\_LB1\_In:** Reset Door - Light button input - Dynamic A
- Q0.2=P0\_AS\_OK:** Robot auto stop - Expansion BT50 relay
- Q0.3=P0\_ES:** Robot emergency stop - Expansion BT50 relay
- GM0.0=P0\_ES\_OK:** Emergency stop OK in Pluto 0

## Pluto 1 Settings – Machine Cabinet

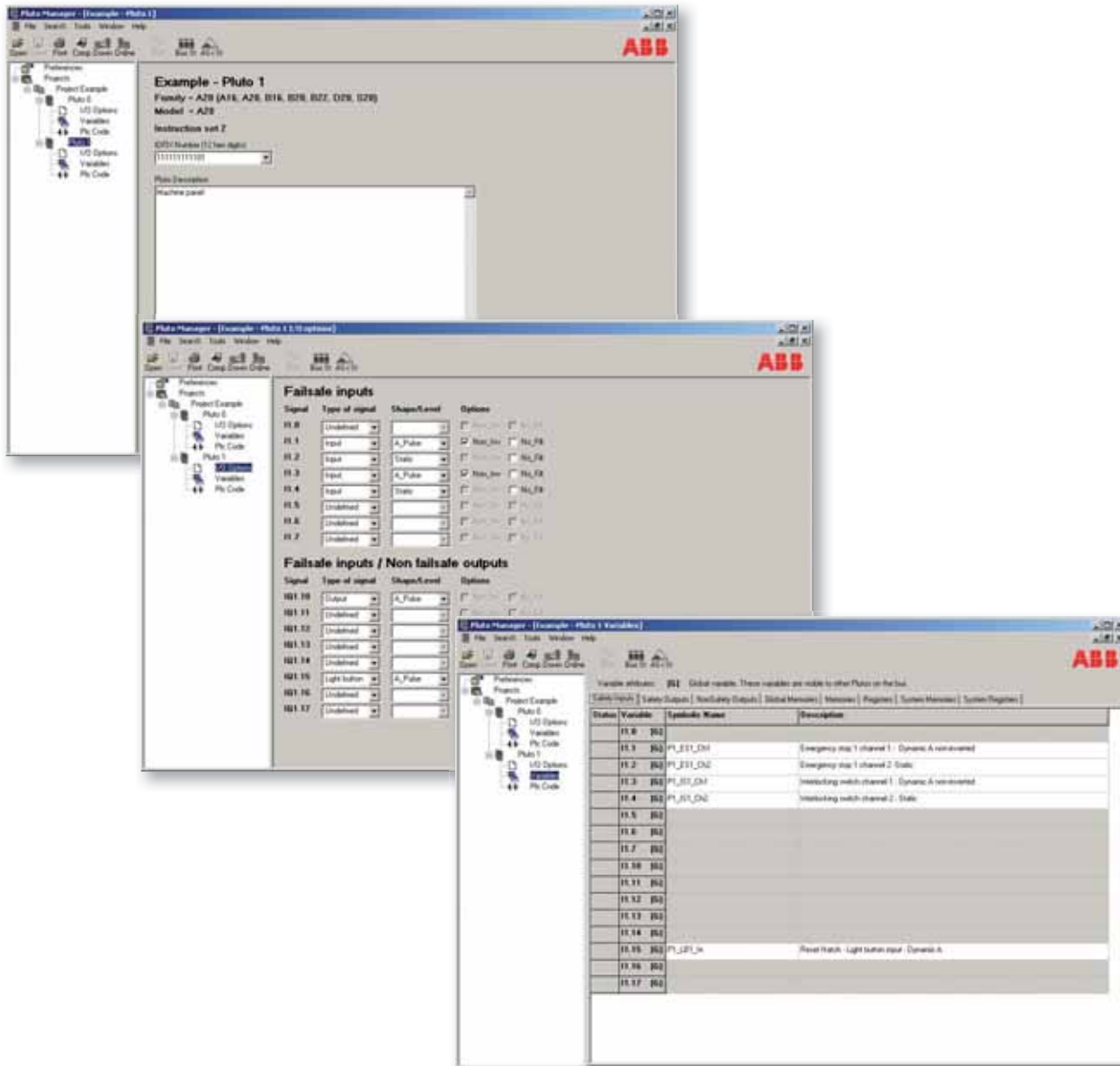

### Pluto 1

**I1.1=P2\_ES1\_Ch1:** Emergency stop 1 channel 1 - Dynamic A non-inverted

**I1.2=P2\_ES1\_Ch2:** Emergency stop 1 channel 2 -Static

**I1.3=P2\_IS1\_Ch1:** Interlocking switch channel 1 - Dynamic A non-inverted

**I1.4=P2\_IS1\_Ch2:** Interlocking switch channel 2 - Static

**I1.15=P2\_LB1\_In:** Reset Hatch - Light button input - Dynamic A

**Q1.0=P2\_ES:** Machine Emergency stop

**Q1.1=P2\_PS:** Machine protective stop

**GM1.0=P2\_ES\_OK:** Emergency stop OK in Pluto 1

**GM1.1=P2\_Hatch\_OK:** Hatch closed

## PLC Code Pluto 0 Settings – Robot Cabinet

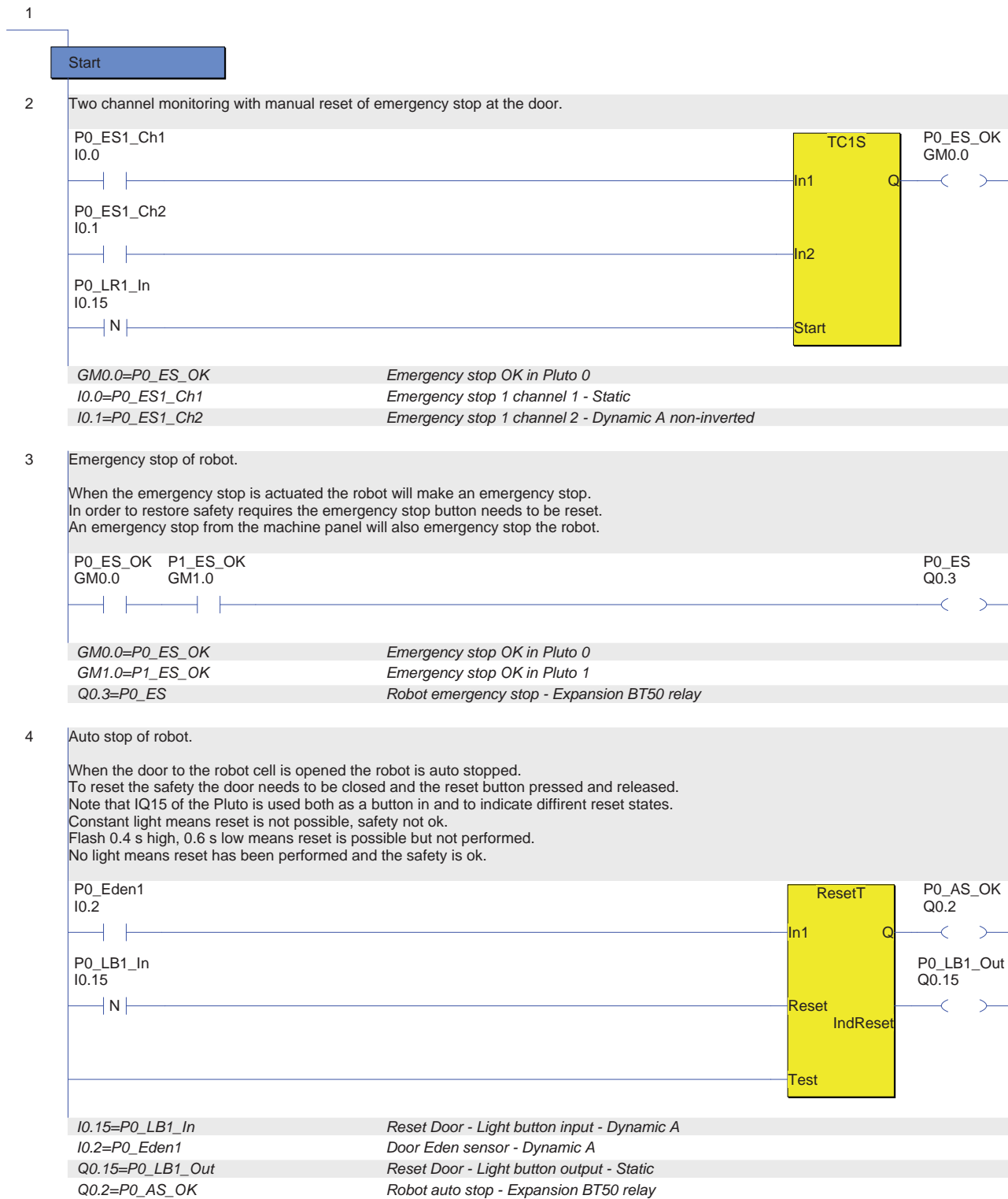

## PLC Code Pluto 0 Settings – Robot Cabinet (continued)

- 5 Alarm 03 - Machine hatch open.
- To generate User Errors (UE) a value of 200 - 299 can be written to the display of the Pluto.  
A check of System Register 11 (SR11) in the Pluto prioritises errors from the Pluto itself over User Errors.
- |                      |                  |                            |                                   |
|----------------------|------------------|----------------------------|-----------------------------------|
| P1_Hatch_OK<br>GM1.1 | P0_AS_OK<br>Q0.2 | SR_ErrorCode=0<br>SR0.11=0 | SR_PlutoDisplay=203<br>SR0.10=203 |
|----------------------|------------------|----------------------------|-----------------------------------|
- 
- |                        |                                              |
|------------------------|----------------------------------------------|
| GM1.1=P1_Hatch_OK      | Hatch closed                                 |
| Q0.2=P0_AS_OK          | Robot auto stop - Expansion BT50 relay       |
| SR0.10=SR_PlutoDisplay | Pluto display figure. For user error: 200+no |
| SR0.11=SR_ErrorCode    | Error code                                   |
- 6 Alarm 02 - Door open.
- To generate User Errors (UE) a value of 200 - 299 can be written to the display of the Pluto.  
A check of System Register 11 (SR11) in the Pluto prioritises errors from the Pluto itself over User Errors.
- |                  |                            |                                   |
|------------------|----------------------------|-----------------------------------|
| P0_Eden1<br>I0.2 | SR_ErrorCode=0<br>SR0.11=0 | SR_PlutoDisplay=202<br>SR0.10=202 |
|------------------|----------------------------|-----------------------------------|
- 
- |                        |                                              |
|------------------------|----------------------------------------------|
| I0.2=P0_Eden1          | Door Eden sensor - Dynamic A                 |
| SR0.10=SR_PlutoDisplay | Pluto display figure. For user error: 200+no |
| SR0.11=SR_ErrorCode    | Error code                                   |
- 7 Alarm 01 - Emergency stop actuated.
- To generate User Errors (UE) a value of 200 - 299 can be written to the display of the Pluto.  
A check of System Register 11 (SR11) in the Pluto prioritises errors from the Pluto itself over User Errors.
- |                   |                            |                                   |
|-------------------|----------------------------|-----------------------------------|
| P0_ES_OK<br>GM0.0 | SR_ErrorCode=0<br>SR0.11=0 | SR_PlutoDisplay=201<br>SR0.10=201 |
|-------------------|----------------------------|-----------------------------------|
- 
- |                        |                                              |
|------------------------|----------------------------------------------|
| GM0.0=P0_ES_OK         | Emergency stop OK in Pluto 0                 |
| SR0.10=SR_PlutoDisplay | Pluto display figure. For user error: 200+no |
| SR0.11=SR_ErrorCode    | Error code                                   |



## PLC Code Pluto 1 Settings – Machine Cabinet

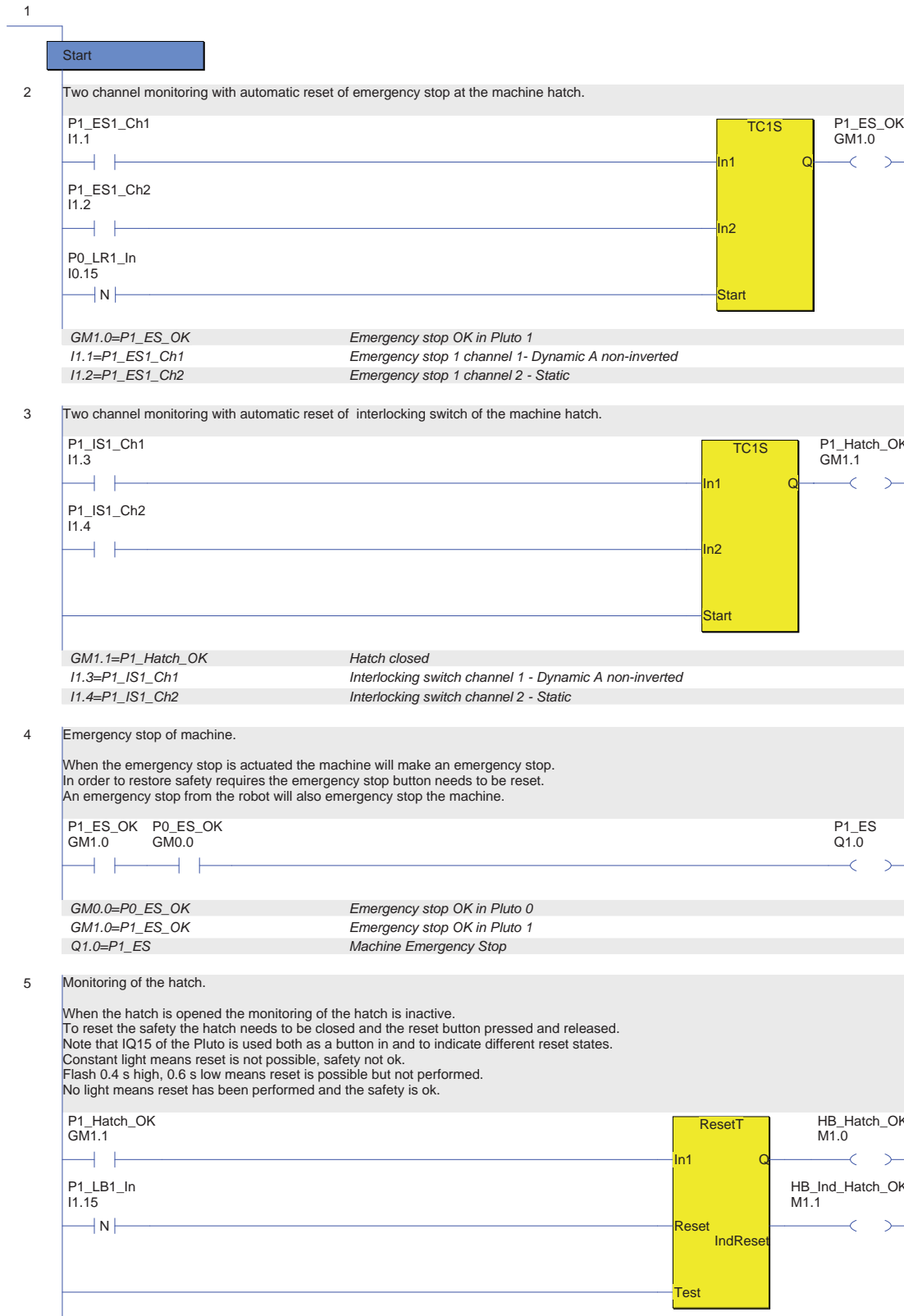

## PLC Code Pluto 1 Settings – Machine Cabinet (continued)

	GM1.1=P1_Hatch_OK	Hatch closed	
	I1.15=P1_LB1_In	Reset Hatch - Light button input - Dynamic A	
	M1.0=HB_Hatch_OK	Help Bit - Hatch closed	
	M1.1=HB_Ind_Hatch_OK	Help Bit - Indication Reset Hatch	
6	Light button indication of the reset of the hatch.		
	If the robot cell's door is closed and reset no light indication is needed inside the cell.		
	HB_Ind_Hatch_OK M1.1	P0_AS_OK Q0.2	P1_LB1_Out Q1.15
	M1.1=HB_Ind_Hatch_OK	Help Bit - Indication Reset Hatch	
	Q0.2=P0_AS_OK	Robot auto stop - Expansion BT50 relay	
	Q1.15=P1_LB1_Out	Reset Hatch - Light button output - Static	
7	Protective stop of the machine.		
	Either the hatch is closed and reset or the door to the robot cell is closed and reset. This means the cell can work with the hatch both open or closed as long as the cell's door is closed and reset.		
	HB_Hatch_OK M1.0	P0_AS_OK Q0.2	P1_PS Q1.1
	M1.0=HB_Hatch_OK	Help Bit - Hatch closed	
	Q0.2=P0_AS_OK	Robot auto stop - Expansion BT50 relay	
	Q1.1=P1_PS	Machine Protective Stop	
8	Alarm 03 - Machine hatch open.		
	To generate User Errors (UE) a value of 200 - 299 can be written to the display of the Pluto. A check of System Register 11 (SR11) in the Pluto prioritises errors from the Pluto itself over User Errors.		
	P1_Hatch_OK GM1.1	P0_AS_OK Q0.2	SR_ErrorCode=0 SR1.11=0
	SR_PlutoDisplay=203 SR1.10=203		
	GM1.1=P1_Hatch_OK	Hatch closed	
	Q0.2=P0_AS_OK	Robot auto stop - Expansion BT50 relay	
	SR1.10=SR_PlutoDisplay	Pluto display figure. For user error: 200+no	
	SR1.11=SR_ErrorCode	Error code	
9	Alarm 02 - Door open.		
	To generate User Errors (UE) a value of 200 - 299 can be written to the display of the Pluto. A check of System Register 11 (SR11) in the Pluto prioritises errors from the Pluto itself over User Errors.		
	P0_Eden1 I0.2	SR_ErrorCode=0 SR1.11=0	SR_PlutoDisplay=202 SR1.10=202
	I0.2=P0_Eden1	Door Eden sensor - Dynamic A	
	SR1.10=SR_PlutoDisplay	Pluto display figure. For user error: 200+no	
	SR1.11=SR_ErrorCode	Error code	
10	Alarm 01 - Emergency stop actuated.		
	To generate User Errors (UE) a value of 200 - 299 can be written to the display of the Pluto. A check of System Register 11 (SR11) in the Pluto prioritises errors from the Pluto itself over User Errors.		
	P1_ES_OK GM1.0	SR_ErrorCode=0 SR1.11=0	SR_PlutoDisplay=201 SR1.10=201
	GM1.0=P1_ES_OK	Emergency stop OK in Pluto 1	
	SR1.10=SR_PlutoDisplay	Pluto display figure. For user error: 200+no	
	SR1.11=SR_ErrorCode	Error code	

# Pluto Gateway

## GATE-P2

Pluto Gateway is a unit providing two-way communication between a Pluto Safety PLC and other field buses.

It is a compact unit mounted on a DIN rail and can be connected anywhere in a Pluto Safety bus. The unit has a common interface with Pluto, i.e. the same cabling, and the Pluto Manager PC program can be used for servicing and — where necessary — for programming. Normally, however, all the settings are made via a DIP switches, which means that programming tools are not required to put the gateway itself into operation.

For programming Pluto there are ready-made function blocks which, via a Pluto gateway, send and receive data from the supervisory system.

### Data from Pluto

Via PROFIBUS, a supervisory PLC system can have access to the I/O and other variables in a Pluto Safety PLC. Global I/O in a Pluto Safety PLC are accessible via PROFIBUS modules in the gateway — one module for each Pluto unit. Local data in Pluto units can be read by a "local data" module together with the PLC codes in the supervisory system.

### Data to Pluto

Via PROFIBUS, a supervisory PLC system can transmit non-safety-related information to a Pluto Safety PLC. A total of 64 Boolean values and 8 different 16-bit registers can be transmitted. Function blocks for these functions are available in Pluto Manager.

### PLC Function Blocks

To simplify the integration of a Pluto gateway PROFIBUS into the supervisory PLC system, ABB Jokab Safety provides ready-made function blocks for several popular brands of PLC. The function blocks make it easier to receive and send information to the Pluto system.

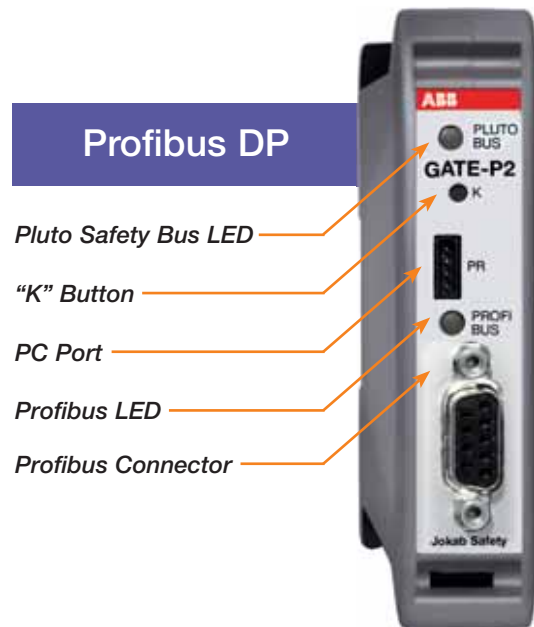

### Applications

- Bi-directional status information from the Pluto Safety PLC
- For Profibus

### Features

- Two-way communication
- Built-in filter function, shared network
- Only 22.5 mm wide
- Can be located anywhere in the databus
- Common interface with Pluto
- Ready-made function blocks

## GATE-P2 Technical Data

Manufacturer	ABB AB/Jokab Safety, Sweden
Ordering information	see page 2:43
Databases	Pluto Safety bus CAN (isolated) PROFIBUS RS485 (isolated)
Pluto Safety bus speeds	100, 200, 250, 400, 500, 800 and 1000 kbit/s (automatic speed detection)
PROFIBUS speed	Up to 12 Mbit/s (automatic speed detection)
PROFIBUS address	Setting via DIP switches (0-99)
PROFIBUS version	DP slave, DP-V0
Connections	
Top	3-pole terminal for Pluto Safety bus (included)
Front	standard 9-pole PROFIBUS connection
Bottom	2-pole terminal for 24 V DC (included)

Status indication	Pluto Safety bus status indication via LED PROFIBUS status indication via LED
Operating voltage	24 V DC, -15% till +20%
Current at 24 V	< 100 mA (recommended fuse $\leq 6$ A)
Dimensions (w x h x d)	22.5 x 101 x 119 mm
Installation	35 mm DIN rail
Temperature	
Ambient temperature	-10°C to + 55°C
Storage and transport	-25°C to + 55°C
Humidity	EN 60 204-1 50% at 40°C (ambient 90% at 20°C)
Classification	
Enclosure	IP 20 - IEC 60 529
Terminals	IP 20 - IEC 60 529

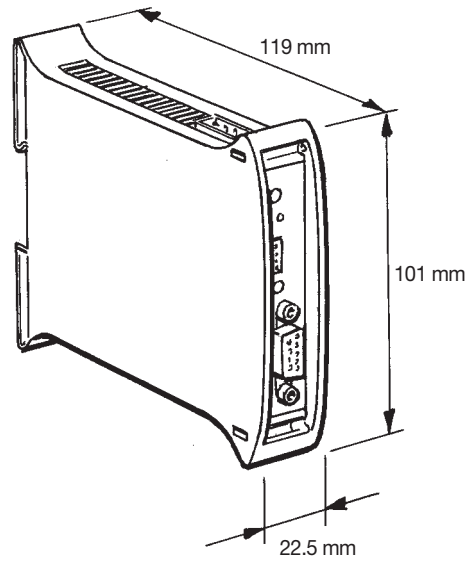
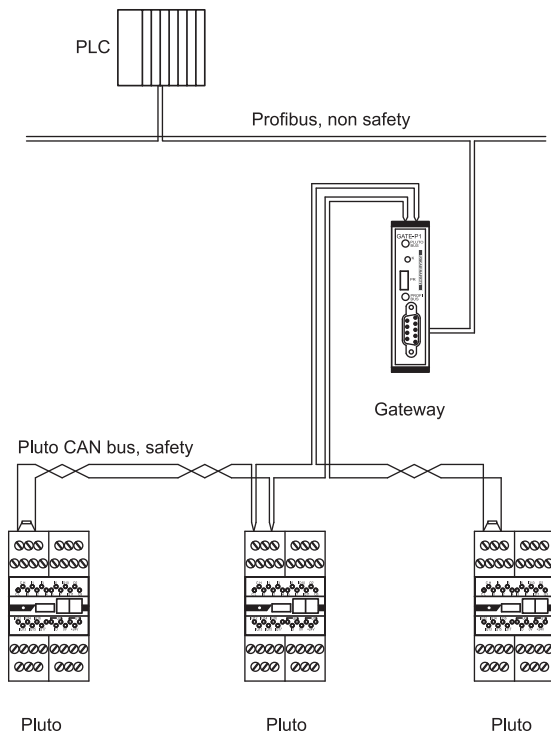

# Pluto Gateway

## GATE-D2

Pluto Gateway is a unit providing two-way communication between a Pluto Safety PLC and other field buses.

It is a compact unit mounted on a DIN rail and can be connected anywhere in a Pluto Safety bus. The unit has a common interface with Pluto, i.e. the same cabling, and the Pluto Manager PC program can be used for servicing and — where necessary — for programming. Normally, however, all the settings are made via a DIP switches, which means that programming tools are not required to put the gateway itself into operation.

For programming Pluto there are ready-made function blocks which, via a Pluto gateway, send and receive data from the supervisory system.

### Data from Pluto

Via DeviceNet, a supervisory PLC system can have access to the I/O and other variables in a Pluto Safety PLC. Global and local data in a PLC to Safety PLC is accessible via DeviceNet "implicit" or "explicit" messages with a maximum of 64 words per gateway.

### Data to Pluto

Via DeviceNet, a supervisory PLC system can transmit non-safety-related information to a Pluto Safety PLC. A total of 64 Boolean values and 8 different 16-bit registers can be transmitted (via DeviceNet "implicit" or "explicit" messages). Function blocks for these commands are available in Pluto Manager.

### Pluto Bridge

A GATE-D2 can also be used to advantage as a CAN bridge when it is required to divide a Pluto Safety bus into several sections. This is particularly useful when long databus cables are needed.

There is also a built-in filter function which makes it possible to block any data that is not required for use on the other side of the bridge, which reduces the databus loading in the other sections and therefore permits longer databus cables.

### ABB Robotics IRC5

PLUTO GATE-D2 has support for integration into an ABB Robotics IRC5-system. The documentation that describes this integration can be obtained via [www.abb.com/lowvoltage](http://www.abb.com/lowvoltage), under Control Products - Safety Products - Programmable Safety Controllers - Gateways - Data.

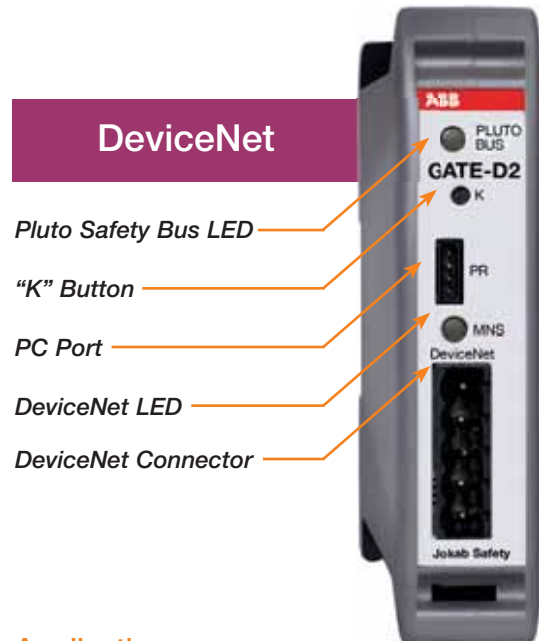

### Applications

- Bi-directional status information from the Pluto Safety PLC
- For DeviceNet and Pluto bridge

### Features

- Two-way communication
- Built-in filter function, shared network
- Only 22.5 mm wide
- Can be located anywhere in the databus
- Common interface with Pluto
- Ready-made function blocks

## GATE-D2 Technical Data

<b>Manufacturer</b>	ABB AB/Jokab Safety, Sweden
<b>Ordering information</b>	see page 2:43
<b>Databases</b>	Pluto Safety bus CAN (isolated) DeviceNet CAN (isolated)
<b>Pluto Safety bus speeds</b>	100, 200, 250, 400, 500, 800 and 1000 kbit/s (automatic speed detection)
<b>DeviceNet speeds</b>	125, 250 and 500 kbit/s (set via DIP switch)
<b>DeviceNet address</b>	Setting via DIP switches (1-63)
<b>DeviceNet Version</b>	ODVA version 2.0
<b>Connections</b>	
Top	3-pole terminal for Pluto Safety bus (included)
Front	5-pole terminal for DeviceNet (included)
Bottom	2-pole terminal for 24 V DC (included)

<b>Status indications</b>	Pluto Safety bus status indication via LED DeviceNet MNS status indication via LED
<b>Operating voltage</b>	24 V DC, -15% till +20%
<b>Current at 24 V</b>	< 100 mA (recommended fuse $\leq 6$ A)
<b>Dimensions (w x h x d)</b>	22.5 x 101 x 119 mm
<b>Installation</b>	35 mm DIN rail
<b>Temperature</b>	
Ambient operating temperature	-10°C to + 55°C
Transport and storage	-25°C to + 55°C
<b>Humidity</b>	EN 60 204-1 50% at 40°C (ambient 90% at 20°C)
<b>Classification</b>	
Enclosure	IP 20 - IEC 60 529
Terminals	IP 20 - IEC 60 529

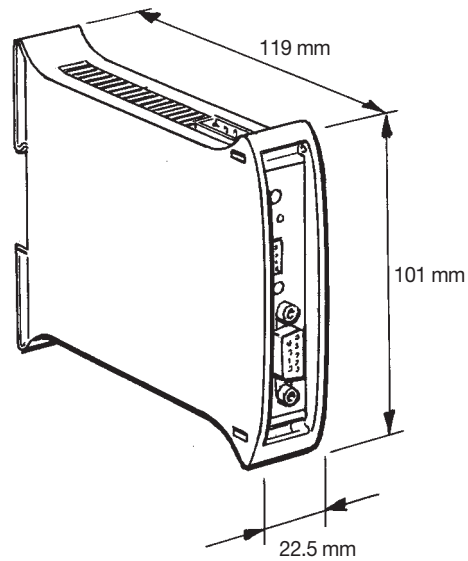
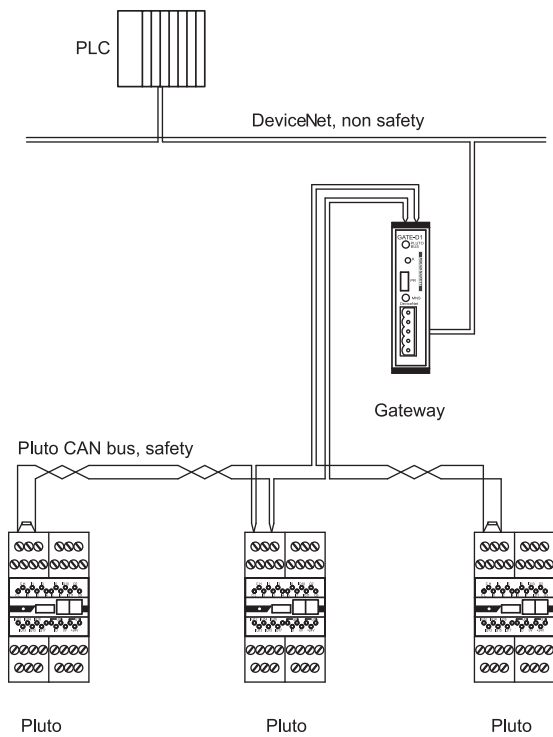

# Pluto Gateway

## GATE-C2

Pluto Gateway is a unit providing two-way communication between a Pluto Safety PLC and other field buses.

It is a compact unit mounted on a DIN rail and can be connected anywhere in a Pluto Safety bus. The unit has a common interface with Pluto, i.e. the same cabling, and the Pluto Manager PC program can be used for servicing and — where necessary — programming. Normally, however, all the settings are made via a DIP switches, which means that programming tools are not required to put the gateway itself into operation.

For programming Pluto there are ready-made function blocks which, via a Pluto gateway, send and receive data from the supervisory system.

### Data from Pluto

Via CANopen, a supervisory PLC system can have access to the I/O and other variables in a Pluto Safety PLC. Global I/Os in a Pluto Safety PLC are accessible via CANopen PDO messages. Local data in Pluto units can be read via CANopen SDO messages together with the PLC codes in the supervisory system.

### Data to Pluto

Via CANopen, a supervisory PLC system can send non-safety-related information to a Pluto Safety PLC. A total of 64 Boolean values and 8 different 16-bit registers can be transmitted (CANopen PDO or SDO messages). Function blocks for these commands are available in Pluto Manager.

### Pluto Bridge

A GATE-C2 can also be used to advantage as a CAN bridge when it is required to divide a Pluto Safety bus into several sections. This is particularly useful when long databus cables are needed.

There is also a built-in filter function which makes it possible to block any data that is not required for use on the other side of the bridge, which reduces the databus loading in the other sections and therefore permits longer databus cables.

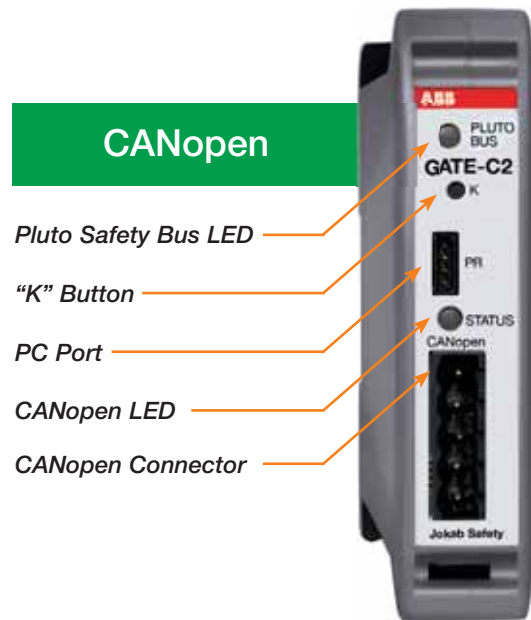

### Applications

- Bi-directional status information from the Pluto Safety PLC
- For CANopen and Pluto bridge

### Features

- Two-way communication
- Built-in filter function, shared network
- Only 22.5 mm wide
- Can be located anywhere in the databus
- Common interface with Pluto
- Ready-made function blocks

## GATE-C2 Technical Data

<b>Manufacturer</b>	ABB AB/Jokab Safety, Sweden
<b>Ordering information</b>	see page 2:43
<b>Databases</b>	Pluto Safety bus CAN (isolated) CANopen CAN (isolated)
<b>Pluto Safety bus speeds</b>	100, 200, 250, 400, 500, 800 and 1000 kbit/s (automatic speed detection)
<b>CANopen speeds</b>	125, 250 and 500 kbit/s (set via DIP switch) 10, 20, 50, 100, 125, 250, 500, 800 and 1000 kbit/s (via software)
<b>CANopen address</b>	Setting via DIP switches or software (1-63)
<b>CANopen version</b>	"Version 4.02 of the CiA Draft Standard 301"
<b>Connections</b>	
Top	3-pole terminal for Pluto Safety bus (included)
Front	5-pole terminal for CANopen (included)
Bottom	2-pole terminal for 24 V DC (included)

<b>Status indications</b>	Pluto Safety bus status indication via LED CANopen status indication via LED
<b>Operating voltage</b>	24 V DC, -15% till +20%
<b>Current at 24 V</b>	< 100 mA (recommended fuse $\leq 6$ A)
<b>Dimensions (w x h x d)</b>	22.5 x 101 x 119 mm
<b>Installation</b>	35 mm DIN rail
<b>Temperature</b>	
Ambient operating temperature	-10°C to + 55°C
Transport and storage	-25°C to + 55°C
<b>Humidity</b>	EN 60 204-1 50% at 40°C (ambient 90% at 20°C)
<b>Classification</b>	
Enclosure	IP 20 - IEC 60 529
Terminals	IP 20 - IEC 60 529

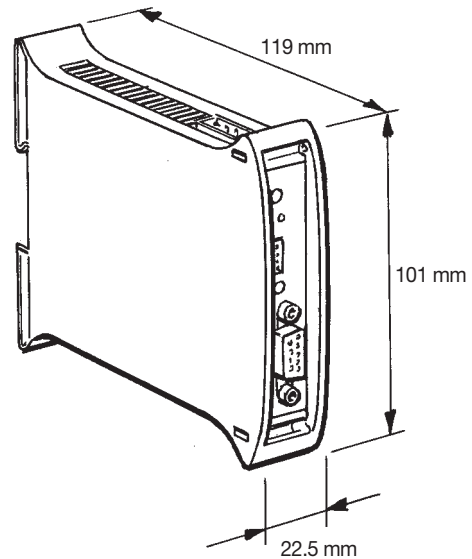
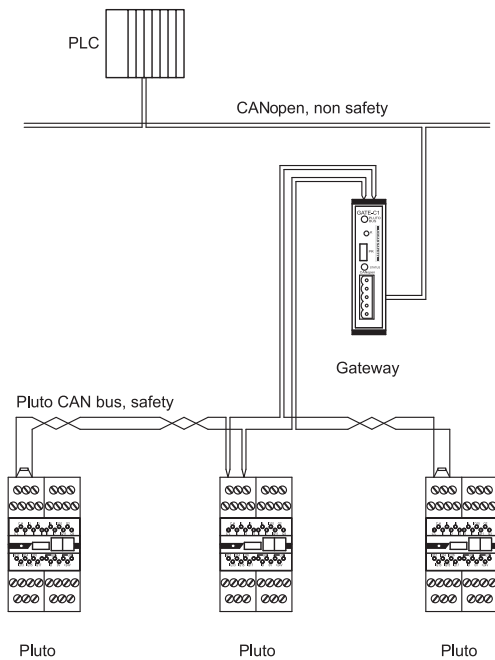



# Pluto Gateway

## GATE-E2

Pluto Gateway is a unit providing two-way communication between a Pluto Safety PLC and other field buses.

It is a compact unit mounted on a DIN rail and can be connected anywhere in a Pluto Safety bus. The unit has a common interface with Pluto, i.e. the same cabling, and the Pluto Manager PC program can be used for servicing and — where necessary — programming. Normally, however, all the settings are made via a DIP switches, which means that programming tools are not required to put the gateway itself into operation.

For programming Pluto there are ready-made function blocks which, via a Pluto gateway, send and receive data from the supervisory system.

### Protocol

PLUTO Gateway GATE-E2 handles the status from and to Pluto Safety PLCs via Ethernet protocols Ethernet/IP, PROFINET, Modbus TCP and a simple binary protocol that uses TCP/IP.

For IP-address configuration, etc. there is a simple web server and a terminal server.

### Data from Pluto

Via one of the Ethernet protocols, a supervisory PLC system can have access to the I/O and other variables in a Pluto Safety PLC. Global I/Os in a Pluto Safety PLC are accessible via the usual I/O transfer in the respective protocol. Local data in Pluto units can be read by special commands together with the PLC codes in the supervisory system.

### Data to Pluto

Via the Ethernet protocol, a supervisory PLC system can transmit non-safety-related information to a Pluto Safety PLC. A total of 64 Boolean values and 8 different 16-bit registers can be transmitted. Function blocks for these functions are available in Pluto Manager.

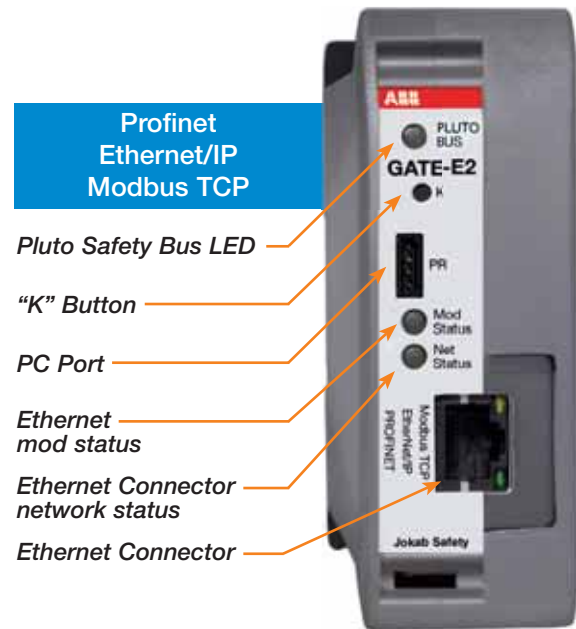

### Applications

- Bi-directional status information from the Pluto Safety PLC
- Profinet, Ethernet/IP, Modbus TCP

### Features

- Two-way communication
- Built-in filter function, shared network
- Can be located anywhere in the databus
- Common interface with Pluto
- Ready-made function blocks

## GATE-E2 Technical Data

<b>Manufacturer</b>	ABB AB/Jokab Safety, Sweden
<b>Ordering information</b>	see page 2:43
<b>Databases</b>	Pluto-bus CAN (isolated) Profinet (isolated) Ethernet/IP (isolated) Modbus TCP (isolated)
<b>Pluto Safety bus speeds</b>	100, 200, 250, 400, 500, 800 and 1000 kbit/s (automatic speed detection)
<b>Ethernet</b>	10/100 Mbit/s Half and full duplex
<b>Ethernet protocol</b>	Status from and to Pluto Safety PLC - EtherNet/IP - PROFINET (in development) - Modbus TCP - Binary server (TCP/IP)  <i>Note that certain combinations of server protocols cannot be used simultaneously.</i>  Gateway status and IP address configuration - Web server - Terminal server (TCP/IP)
<b>EtherNet/IP</b>	According to ODVA "CIP Edition 3.2" and "EtherNet/IP Adaption of CIP Edition 1.3" Minimum RPI of 50 ms
<b>PROFINET</b>	PROFINET
<b>Modbus TCP</b>	According to the Modbus organization, version 1.0b (approx. 20 messages per second)
<b>Binary server (TCP/IP)</b>	Simple TCP/IP protocol to send status from/to the Pluto system
<b>Web server</b>	For simple sharing of IP addresses

<b>Terminal server (TCP/IP)</b>	Simple server with the same commands as via the serial programming port in the unit
<b>IP address</b>	Static sharing via web server or via programming port
<b>Gateway configuration</b>	Takes place via EtherNet/IP, PROFINET, Modbus TCP or via the binary TCP/IP server
<b>Connections</b>	
Top	3-pole terminal for Pluto Safety bus (included)
Front	Ethernet connection via RJ-45 (screened cable cat. 5e FTP)
Bottom	2-pole terminal for 24 V DC (included)
<b>Status indications</b>	Pluto Safety bus status indication via LED (Pluto Safety bus) Ethernet module status indication via LED (Mod Status) Ethernet network status indication via LED (Net Status)
<b>Operating voltage</b>	24 V DC, -15 % till +20 %
<b>Current at 24 V</b>	< 150 mA (recommended fuse $\leq 6$ A)
<b>Dimensions (w x h x d):</b>	35 x 101 x 120 mm
<b>Installation</b>	35 mm DIN rail
<b>Temperature</b>	
Ambient operating temperature	-10°C to + 55°C
Transport and storage	-25°C to + 55°C
<b>Humidity</b>	EN 60 204-1 50 % at 40°C (ambient) 90 % at 20°C)
<b>Enclosure classification</b>	
Enclosure	IP 20 - IEC 60 529
Terminals	IP 20 - IEC 60 529

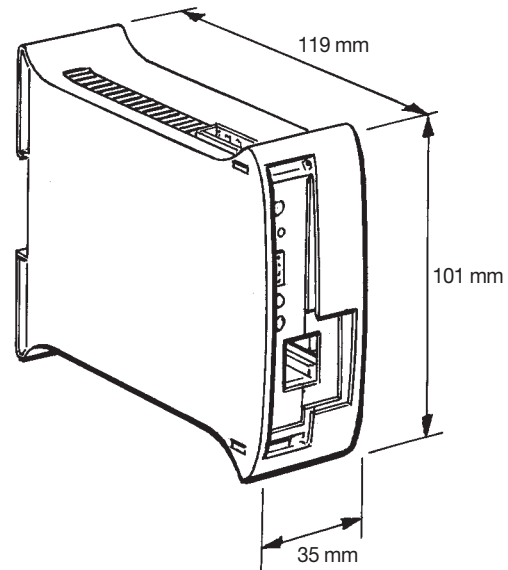
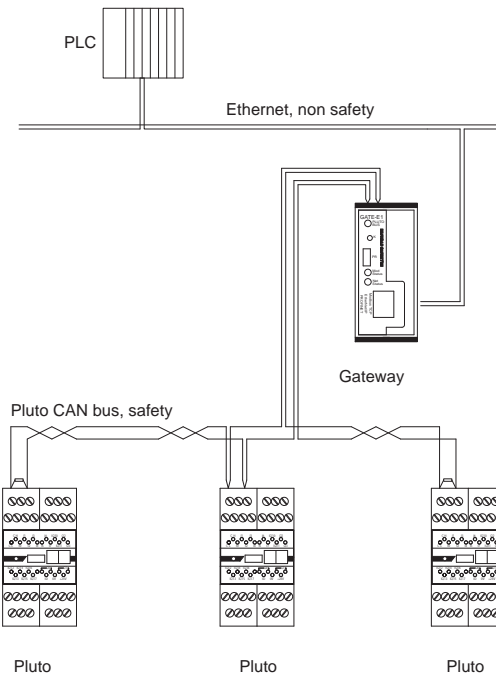

# Pluto Safety Encoders

## Rotational Absolute Value Sensor for Safe Positioning

This rotational absolute encoder, together with a Pluto Safety PLC, can be used for safe position determination. This is particularly useful in the case of such equipment as gantry robots, industrial robots, etc. Also in eccentric shaft presses, existing cam mechanisms can be replaced by absolute value position sensors for safe positioning. The sensors are configurable for single and multi-turn applications.

Up to 16 absolute encoders can be connected to a Pluto CAN databus. A Pluto on the databus reads the sensor values, which are evaluated. With a special function block in the PLC code, it is possible to design two-channel solutions with the sensors. The user can obtain safe values for position and speed from these values. This enables supervision of stationary and overspeed conditions.

The absolute value sensors are standard sensors with modified software to meet the safety requirements.



Safety Encoders  
RSA 698

### Applications

- Safe position and speed determination of machine movements

### Features

- High resolution
- Selectable resolution
- Connected directly to the Pluto Safety bus
- Ready-made function blocks



*Example of an application where 2 sensors provide safe position determination in a gantry robot.*

## Safe Encoder RSA 698 Technical Data

Manufacturer	ABB AB/Jokab Safety, Sweden
Ordering information	see page 2:44
Temperature	
Ambient temperature	-40°C .. +70°C
Transport and storage	-30°C .. +70°C
Ingress protection class	IP-67 in accordance with IEC 60529
At shaft inlet	IP-66 in accordance with IEC 60529
Vibration (55 to 2000 Hz)	< 100 m/s <sup>2</sup> in accordance with IEC 60068-2-6
Shock (6ms)	< 2,000 m/s <sup>2</sup> in accordance with IEC 60068-2-27
Material, enclosure	Aluminium
Surface treatment	Anodized
Weight	Approx. 400g
Resolution, total	25 bit 13 bits, 8192 positions per rotation 12 bits, 4096 rotations
Accuracy	± 1 LSB (Least Significant Bit)
Operating voltage	9-36 V dc
Polarity-protected	Yes
Short-circuit protected	Yes
Databus speed	10 kbit/s - 1 Mbit/s
Code type	Binary
Programmable functions	Resolution, 0 position
Current consumption	50 mA at 24V dc
Max current consumption	100 mA

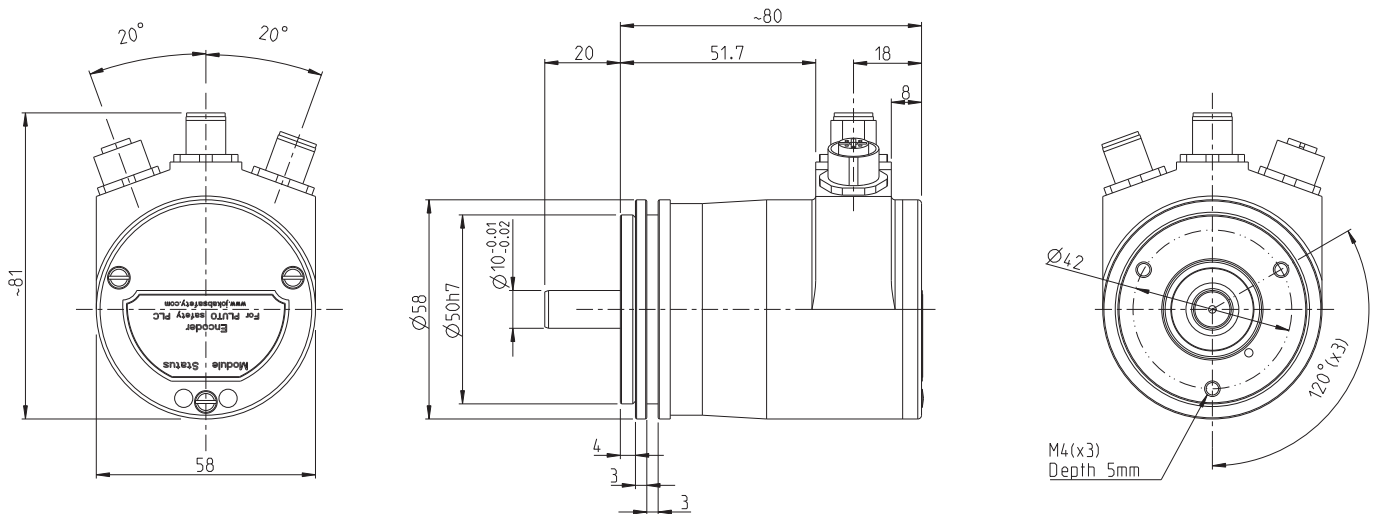
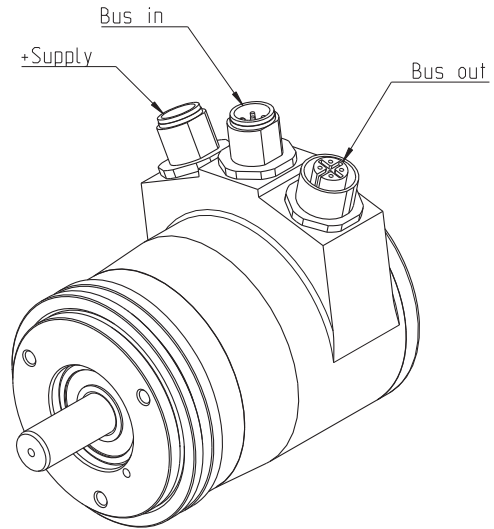

# Safety Encoder Descriptions of Inputs and Outputs

## Safe Encoder

Function block for a single-turn encoder that generates safe position and speed values from two absolute encoders.

### Function

The block reads and evaluates one absolute encoders. The position value is sent to the 'Position' output. The 'Speed' output is the average value for the speed, at the rate of pulses/10 ms. If an error occurs, the 'OK' output is set to zero. In certain applications the values of 'Position' and 'Speed' are used in conjunction with the 'OK' output.

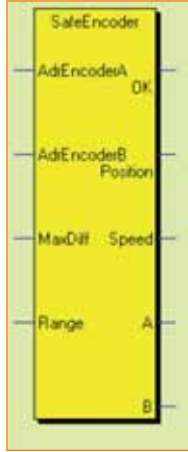

## Descriptions of Inputs and Outputs

- AdrEncoderA: Encoder A node address
- AdrEncoderB: Encoder B node address
- MaxDiff: Max allowed deviation between the encoders (max 2% of Range)
- Range: Number of increments per revolution
- OK: Set when encoders are working OK and the position values are within the margin set by 'MaxDiff'
- Position: Position value
- Speed: Speed value as increments/10ms
- A: Encoder A position. Must not be used in PLC program!
- B: Encoder B position. Must not be used in PLC program!

*Notes: Position values from single encoders are only available for adjustment purposes and must NOT be used for safety.*

*When error occurs 'Position' = -1, 'Speed' = -32768 and the OK output will be reset.*

## Safe Encoder Multiturn

Function block for a multi-turn encoder that generates safe position and speed values from two absolute encoders. Operating system 2.4.4 or higher is required.

### Function

The block reads and evaluates two absolute encoders. The average value for the two sensors is calculated and sent to the 'Position' output. The 'Speed' output is the average value for the speed, at the rate of pulses/10 ms. The block monitors that the encoder position values do not differ by more than the input value set by 'MaxDiff'. If an error occurs, the 'OK' output is set to zero. In certain applications the values of 'Position' and 'Speed' are used in conjunction with the 'OK' output.

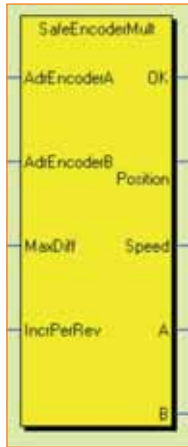

## Descriptions of Inputs and Outputs

- AdrEncoderA: Encoder A node address
- AdrEncoderB: Encoder B node address
- MaxDiff: Max allowed deviation between the encoders (max 2% of IncrPerRev)
- IncrPerRev: Number of increments per revolution
- OK: Set when encoders are working OK and the position values are within the margin set by 'MaxDiff'
- Position: Position value
- Speed: Speed value as increments/10ms
- A: Encoder A position. Must not be used in PLC program!
- B: Encoder B position. Must not be used in PLC program!

*Notes: Position values from single encoders are only available for adjustment purposes and must NOT be used for safety.*

*When error occurs 'Position' = -1, 'Speed' = -32768 and the OK output will be reset.*

## Encoder Cam

Function block for electronic cam gear.

### Function

Output Q is activated if the value of the input register 'PosReg' is within the limits for 'MinPos' and 'MaxPos'.

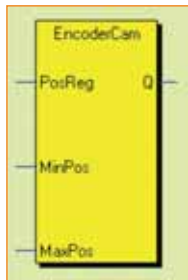

## Descriptions of Inputs and Outputs

- PosReg: Input for the position value
- MinPos: Minimum limit value
- MaxPos: Maximum limit value

*Note: It is possible to specify a value that defines the sensor's zero position. Position <0 is not permitted.*

*Example: If MinPos = 3000 and MaxPos = 200, Q is activated when the position is greater than 2999 or less than 201.*

# Pluto Manager

## A Programming Tool for your Safety Functions

Pluto Manager is a software tailored for the Pluto Safety PLC. Programming is done in ladder, and together with the function block, creates the structure of your safety functions. The software comes with predefined function blocks approved by TÜV to facilitate the work on designing the safety functions. Pluto Manager gives you a structured overview of Plutos, gateways and peripheral components in large and small projects. It gives you an overview and control of the sensors and actuators, and the reactions between them. Pluto Manager also contains manuals for the software and hardware that are connected and need to be handled through the program.

The interface gives the option to get the status directly from Pluto's two bus options, AS-i and Pluto bus. There are also diagnostic functions and the option to export data.

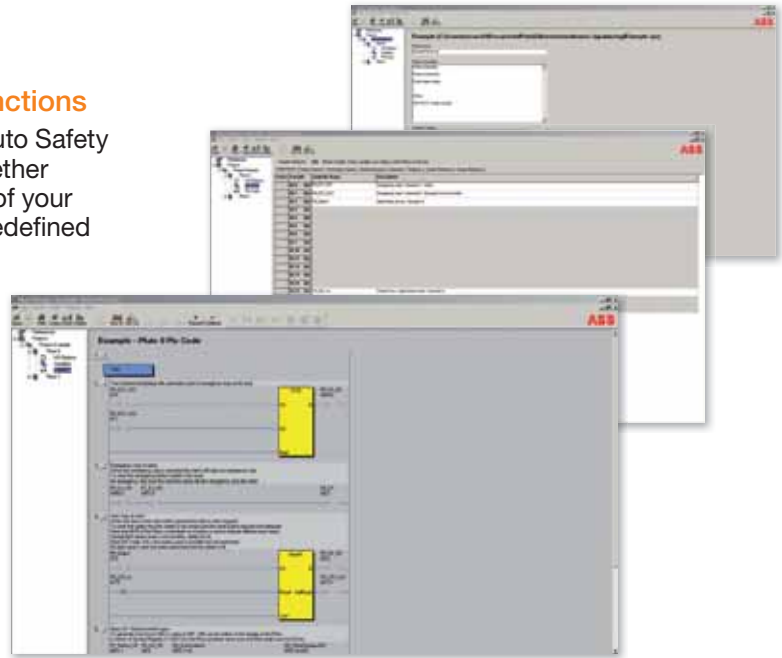

## Systematic Working Method through Project Management

### Step 1 - Configuration of I/O

In every started project, each Pluto is defined individually. Its inputs and outputs are configured as desired and depending on what they connect to. Pluto's IQ ports are also configured here as inputs or outputs, dynamic or static signals.

### Step 2 - Naming of Variables

After configuration the system's variables are determined. Inputs (I), outputs (Q), remanent memories (M), global auxiliary memories for bus communication (GM) and registers (R) are given names that can be used in place of the actual variable designation in the PLC program.

### Step 3 - Ladder Programming

The program is built using the named variables connected to inputs and outputs. The programming language has a full range of instructions, similar to standard PLCs on the market—with timers, arithmetic, sequence programming etc.

The project is then downloaded to Pluto via a programming cable. This program is distributed simultaneously through bus communication to the other Plutos in the project. In this way, you need only access a single Pluto where each Pluto gets the right information specified in your project.

Pluto Manager is included when purchasing the Pluto Safety PLC. The software is Windows based and can be downloaded free from [www.abb.com/lowvoltage](http://www.abb.com/lowvoltage).

## Applications

- Software for the Pluto Safety PLC
- A tool to structure the safety functions

## Features

- Software included with purchase
- Downloaded from [www.abb.com/lowvoltage](http://www.abb.com/lowvoltage)
- Ready to use function blocks for your safety components
- Contains TÜV-approved function blocks
- Provides an overview of the current projects and your Plutos
- Easy programming through ladder language

## Pluto Manager Standards and Special Function Blocks

The safety designer has complete freedom to program the safety functions or to use TÜV-approved pre-defined safety function blocks.

### Blocks in the Standard Library (func05):

1. Two-channel function with input for start
2. Two-channel function with test input
3. Two-channel function with test and reset inputs, and reset indication. See example.
4. Two-channel function with simultaneous requirement.
5. Single channel function with input for start.
6. Single channel function with start and test inputs.
7. Single channel function with reset and test inputs.
8. Two-channel function with max. time limitation (equivalent to JSHT2). Time begins to count down when both inputs are activated.
9. Two-channel function with max. time limitation (equivalent to JSHT2). Time begins to count down when one of the inputs is activated.
10. Single channel pulse function, e.g. for timed reset.
11. Two-channel pulse function, e.g. for timed reset.
12. Two single channel bypass connection functions with max. time limiting.
13. Single channel bypass connection function with max. time limiting.
14. Two-channel bypass connection function with max. time limiting and simultaneous requirement.
15. Two-channel safety function with max. time limited bypass connection.
16. Two-hand control. See example.
17. Counter which counts up to preset value.
18. Counter which counts down from preset value to 0.
19. Off delay.
20. Muting lamp\_Q16.
21. Muting lamp\_Q17.
22. Muting lamp\_W\_Q16. With possibility to set the power level in Watts.
23. Muting lamp\_W\_Q17. With possibility to set the power level in Watts.
24. Light curtain with single cycle operation.
25. Light curtain with single cycle operation and reset selection.
26. Multiplication.
27. Division.

### Other Function Blocks

1. Safety absolute encoder.
2. Electronic cam.
3. External communication.

### Special Function Blocks

1. Program library with program block for eccentric shaft presses.
2. Custom special function blocks can be made available.

### TC1RTI Block 3 Example

#### Two-channel function with test and reset inputs, and reset indication

■ In1 and In2 are safety inputs, to which the safety device outputs are connected.

■ Test is a condition that must be true at the moment of switching on, and can be used for monitoring external components. Test must be true before the Reset input closes, i.e. the function block cannot be initiated by Test.

■ Reset is a supervised reset input and must be activated (positive flank) after the other inputs have activated for the function output to be activated.

■ The IndReset output is activated when the function block is 0 and flashes when the function block is ready for resetting.

■ The TCfault output is activated in the case of a two-channel fault, i.e. if the function block is activated and only one of In1 and In2 opens and closes.

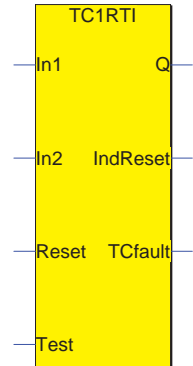

### Description

The function block acts as a conventional two-channel safety relay with dual and supervised inputs (In1, In2).

### Block 16 Example

#### Two-hand control for devices with NO/NC + NO/NC

■ Right\_NO is right handed NO contact

■ Right\_NC is right handed NC contact, etc.

■ The test is a condition that must be met before any of the other inputs are actuated and can be used for monitoring external components.

### Function

In stand-by, Right\_NO must be 0, Right\_NC 1, Left\_NO 0 and Left\_NC 1. In order to start, these four inputs switch the condition within 0.5 seconds and then retain their conditions. After shut-down, all inputs must return to stand-by before any restart can be made.

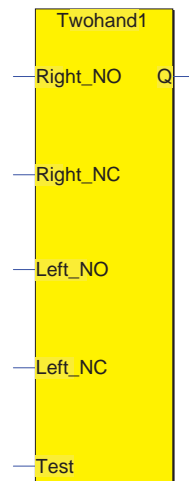

# Connection Example Contents

## HB0001A

Pluto with Smile Emergency  
Stop Unit + Reset via M12-3E and  
Adam via Tina 4A..... 2:41

## HB0002A

Pluto with 5 Eden Units  
for 2 Zones via M12-3E and Tina 4A..... 2:41

## HB0003A

Pluto with 5 Smile Emergency  
Stop Units via Tina 11A and Tina 4A..... 2:42

## HB0004A

Pluto with Different Zones  
for Eden + Reset and 2 Eden Units  
via M12-3E .....2:42



# HB0001A Connection Example

## Pluto with Smile Emergency Stop Unit + Reset via M12-3E and Adam via Tina 4A

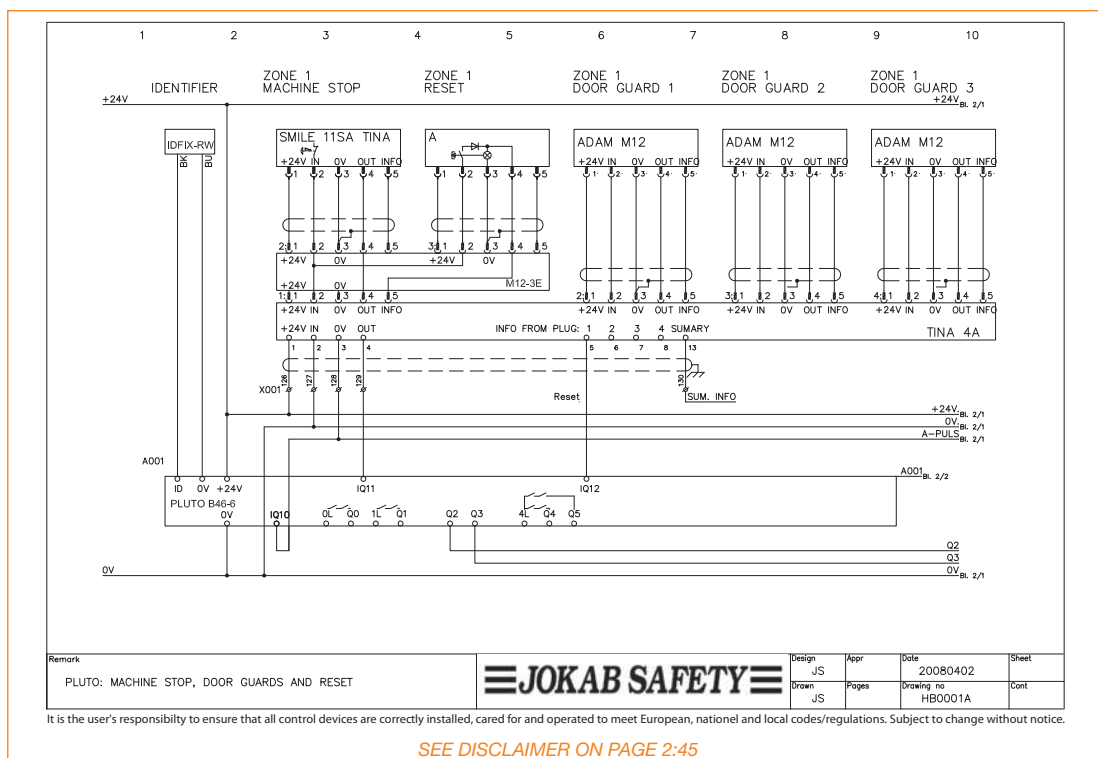

# HB0002A Connection Example

## Pluto with 5 Eden Units for 2 Zones via M12-3E and Tina 4A

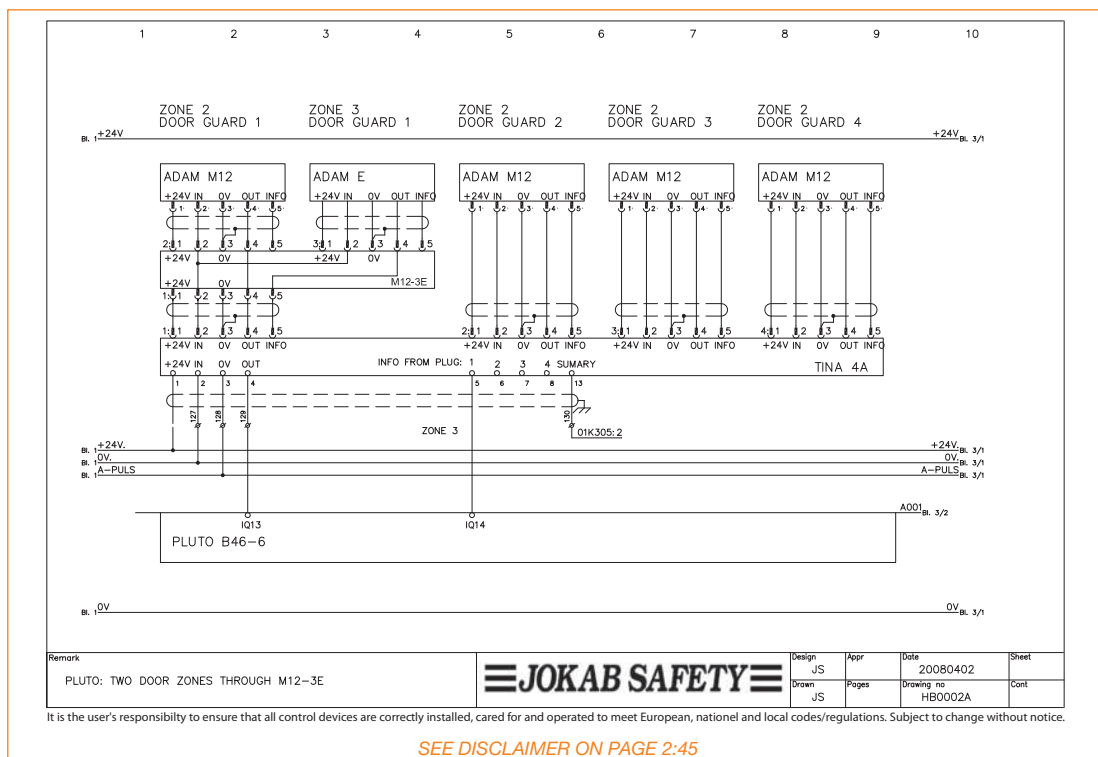

# HB0003A Connection Example

## Pluto with 5 Smile Emergency Stop Units via Tina 11A and Tina 4A

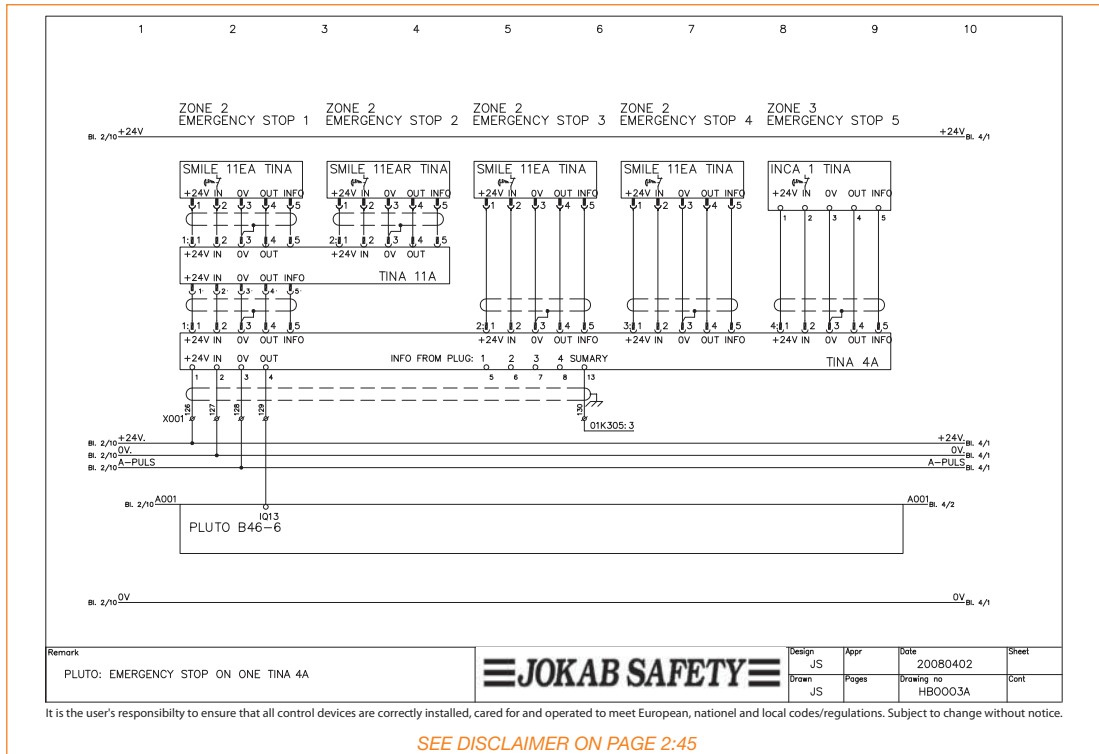





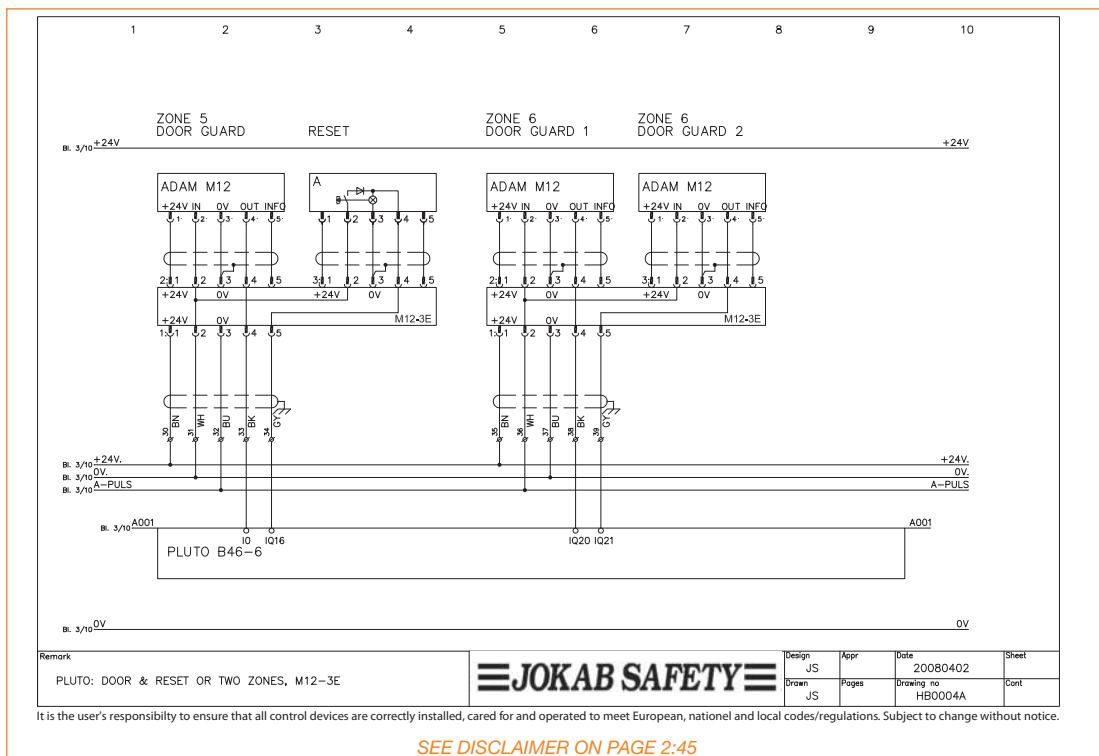



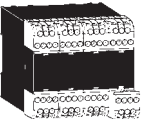

# HB0004A Connection Example

## Pluto with Different Zones for Eden + Reset and 2 Eden Units via M12-3E



## Component List - Pluto Safety PLC



Designation		Ordering Information	Description
Pluto A20		2TLA020070R0300	Safety PLC with 8 failsafe inputs + 8 non-failsafe outputs/failsafe inputs + 2 individual failsafe relay outputs + 2 individually failsafe transistor outputs. For use with Pluto safe bus.
Pluto S20		2TLA020070R0500	Same as A20 except without Pluto safe bus and without current monitoring on Q16 + Q17.
Pluto B16		2TLA020070R0700	Same as B20 except without safety outputs Q0 - Q3.
Pluto B20		2TLA020070R0600	Same as A20 except without current monitoring on Q16 + Q17.
Pluto B46-6		2TLA020070R1700	Safety PLC with 24 failsafe inputs + 16 non-failsafe outputs/failsafe inputs + 4 individual failsafe relay outputs + 2 individually failsafe transistor outputs. For use with Pluto safe bus and/or a Pluto Safety databus.
Pluto S46-6		2TLA020070R1800	Same as B46-6 except without a databus.
GATE-P2 Gateway Pluto Profibus DP		2TLA020071R8000	Gateway for 2-way communication between the Pluto bus and Profibus.
GATE-D2 Gateway Pluto DeviceNet		2TLA020071R8200	Gateway for 2-way communication between the Pluto bus and DeviceNet.
GATE-C2 Gateway Pluto CANopen		2TLA020071R8100	Gateway for 2-way communication between the Pluto bus and CANopen.
GATE-E2 Gateway Pluto Ethernet		2TLA020071R8300	Gateway for 2-way communication between Pluto databus and Profinet, Ethernet/IP, Modbus TCP.

## Component List - Pluto Safety PLC

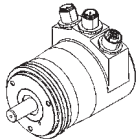
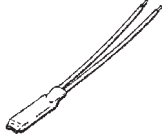
Designation	Ordering Information	Description
IDFIX-R	2TLA0200070R2000	Identifier - assigns Pluto a specific address.
IDFIX-RW	2TLA0200070R2100	Identifier - assigns Pluto an address. This version is programmable.
IDFIX-DATA	2TLA0200070R2300	Identifier - to give Pluto AS-i a specific address.
IDFIX-PROG	2TLA0200070R2400	Identifier - for single Plutos, assigns Pluto a specific address. Allows program storage and retrieval.
R-120	2TLA0200070R2200	Terminating resistance for Pluto databus.
Safe Encoder Model RSA 698	2TLA0200070R3700	Rotational absolute encoder used for safe position determination, and/or speed.
HMI Display	2TLA850015R1100	3.5" TFT-LCD touch screen display, 320x240pixels and 64k colors. RS422/RS485, RS232, Ethernet and USB communication.
HMI Display	2TLA850015R1300	5.7" TFT-LCD touch screen display, 320x240pixels and 64k colors. RS422/RS485, RS232, Ethernet and USB communication.
HMI Display	2TLA850015R1500	3.5" TFT-LCD touch screen display, 320x240pixels and 16 grayscales. RS422/RS485, RS232, Ethernet and USB communication.
HMI Display	2TLA850015R1600	5.7" TFT-LCD touch screen display, 320x240pixels and 16 grayscales. RS422/RS485, RS232, Ethernet and USB communication.
HMI Display	2TLA850015R1700	6.5" TFT-LCD touch screen display, 640x480 pixels. 64k colors. RS422/RS485, RS232, Ethernet and USB communication. Compact Flash Slot.
HMI Software Information Designer	2TLA850015R2300	For Exter and Cimrex terminals For use with Windows XP/Vista.

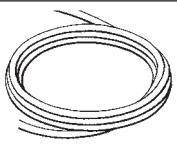
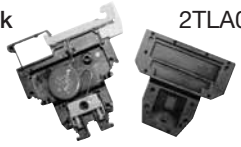

## Component List - Pluto Safety PLC

Designation	Ordering Information	Description
Bus Cable 	2TLA020070R3000	CAN-Bus cable - yellow 2 x 0.50 mm <sup>2</sup> .
	2TLJ020070R3100	CAN-Bus halogen-free cable - yellow 2 x 0.50 mm <sup>2</sup> .
Terminal Block with 12nf Capacitor 	2TLA020070R3200	Modular terminal block with a 12nF radio interference suppression capacitor between clamping connector and DIN rail, separate ground connection, for mounting on Din Rail, terminal width: 6.2 mm, terminal height: 69 mm, Includes pre installed end barrier.
Ceramic Capacitor 	2TLA850015R2100	12nf, X1 440VAC, Y2 250VAC, 20 percent tolerance.
Programming Cable	2TLA020070R5600	RS232 Programming Cable.
Programming Cable	2TLA020070R5800	USB Programming Cable.
Programming Cable	2TLA850015R2200	HMI Programming Cable 3m.

This document and any attachments may include suggested specifications, drawings, schematics and similar materials from ABB Inc. Use of such information and/or documentation by the recipient is subject to and conditioned upon your acceptance of the terms of the General Document Disclaimer which can be found at [www.jokabsafetyna.com](http://www.jokabsafetyna.com). Your acceptance of the terms of such General Document Disclaimer is conclusively presumed unless you notify ABB in writing of your disagreement with the terms of such Disclaimer immediately upon receipt of this document and you return to ABB all specifications, drawings, schematics and similar materials provided to you by ABB.

Notes

# Pluto AS-i Safety

Simplify construction of systems!  
Provides a flexible system!  
Allows easy expansion of the system!

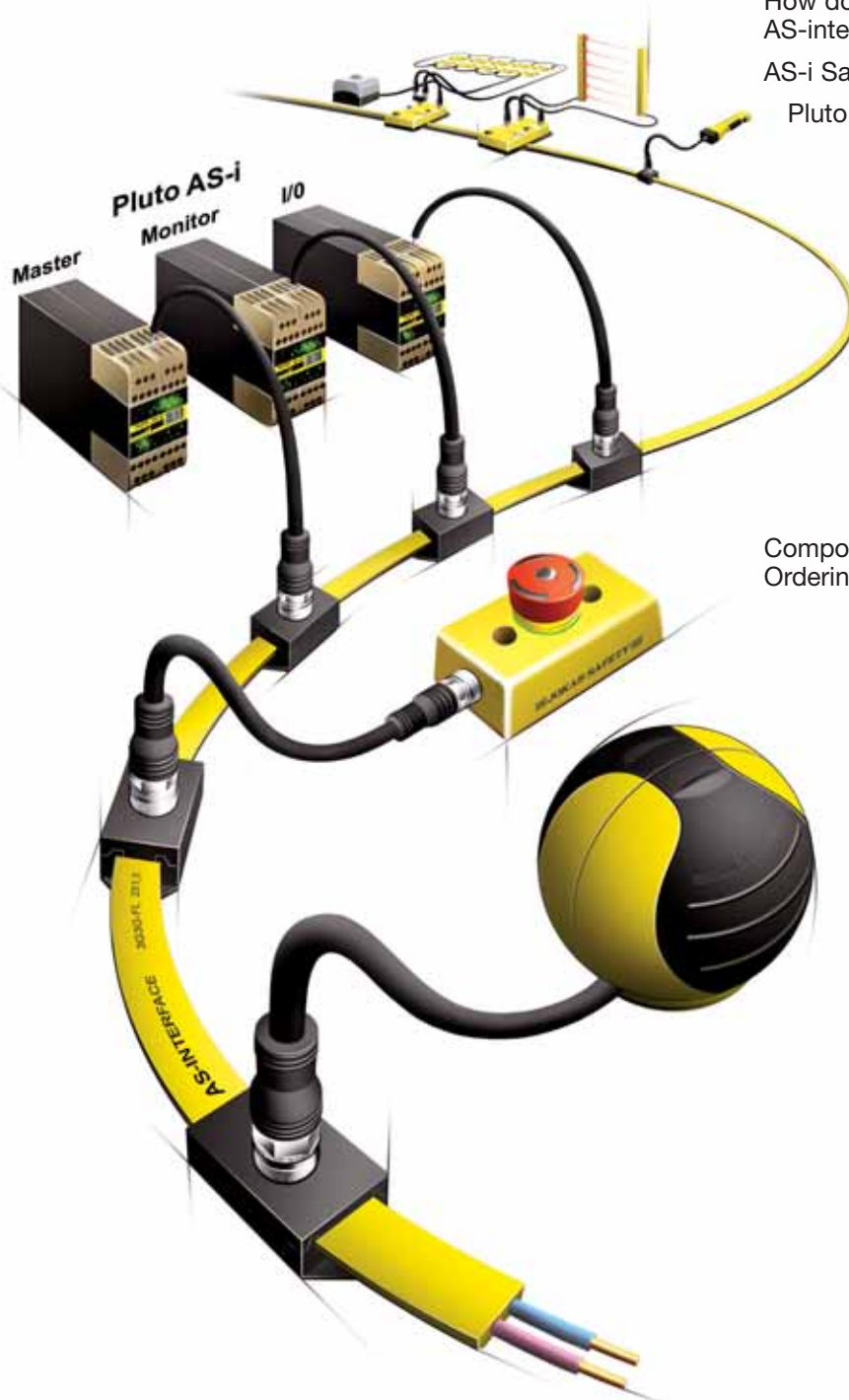

Why should I use the Bus System at Component Level? .....	3:2
How does the Bus System AS-interface work?.....	3:3
AS-i Safety from ABB Jokab Safety .....	3:4
Pluto AS-i Safety PLC.....	3:6
Technical Information .....	3:7
Technical Data .....	3:9
Why should I use the Safety Node URAX?.....	3:11
Safety Node URAX-A1/A1R .....	3:12
Safety Node URAX-B1R.....	3:14
Safety Node URAX-C1/C1R.....	3:16
Safety Node URAX-D1R.....	3:18
Safety Node URAX-E1 .....	3:20
Non-Safe Node FLEX.....	3:22
Component List and Ordering Information .....	3:23

# Why should I use the Bus System at a Component Level?

## ...to provide simplicity in the construction of systems!

The AS-i system provides benefits both when the system is planned and installed. A single network can be divided into monitoring and control of different work zones. The zones can be dependent on each other or not, even though they are controlled and are connected to the same general process.

## ...to save installation time!

Components designed for the AS-i bus system can easily connect to the network wherever this is required. The required function is then selected in the control system.

## ...as it provides a flexible system!

You can use the AS-i cable to move, replace or add new safety products anywhere as needed. Additional monitors such as Pluto AS-i can also be connected in the same way.

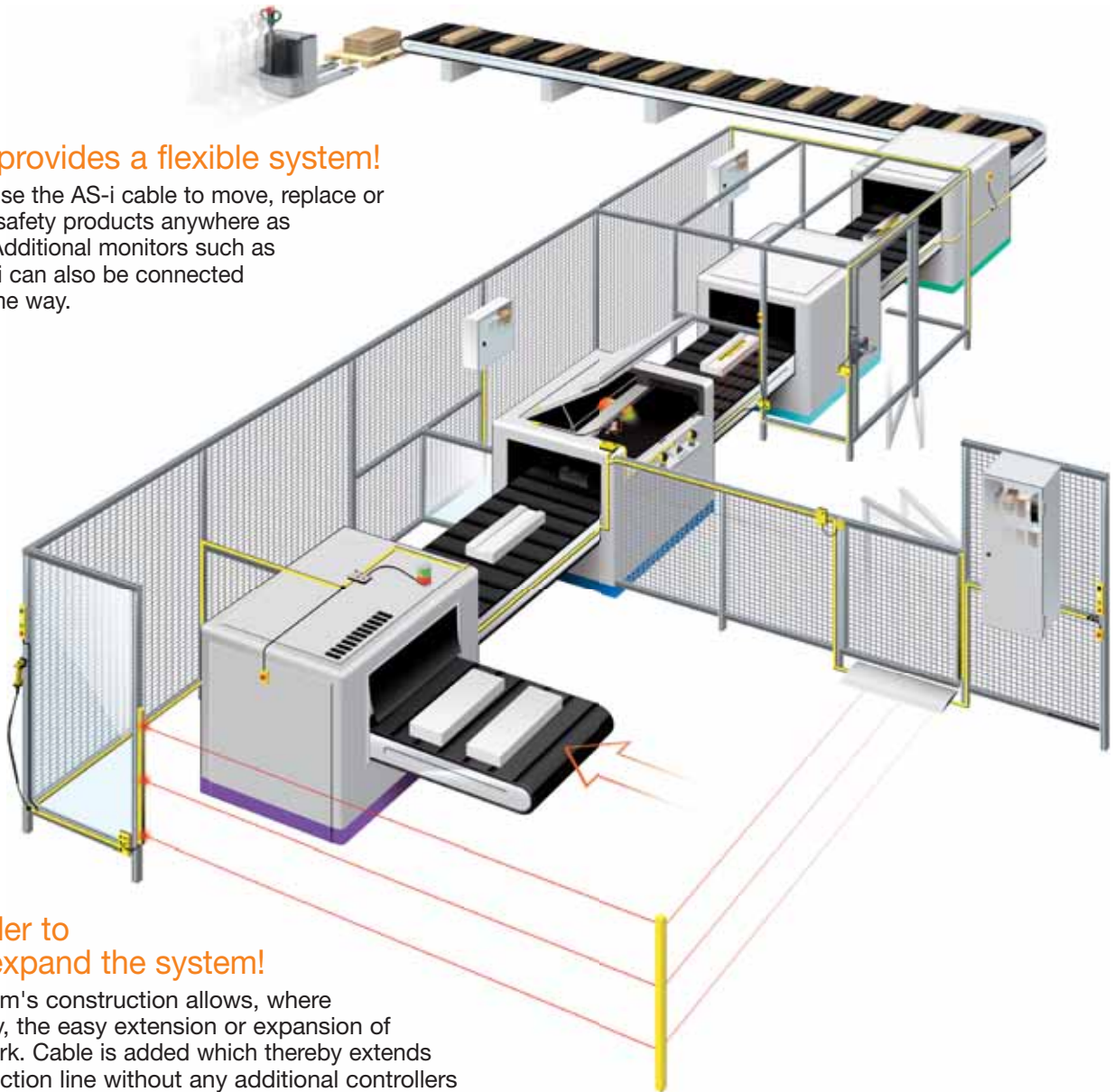

## ...in order to easily expand the system!

The system's construction allows, where necessary, the easy extension or expansion of the network. Cable is added which thereby extends the production line without any additional controllers being installed.



## How Does the Bus System AS-interface work?

The AS-i system is distinguished by its special yellow profile cable. The cable connects all sensors, transducers and actuators on the network to a supervisor system. The component parts of a system can include both non-safe and safe products. This means that both operational and safety related products can be mixed in a network. The bus system drives a Supervisor-Subordinate (node) configuration where each I/O module corresponds to a common supervisor.

Communication takes place through the yellow cable which also provides the nodes with supply voltage. The installation of the cable is usually done along a production line or centrally around the AS-i system's I/O products. After commissioning the system can always be expanded by adding branches or extensions to the cable. In a similar way, more products can be added, moved or replaced. The changes are easily made in the software to the controller. With the AS-i concept, decentralized systems can be designed with all products, non-safe and safe monitored by a device. This advantage means that the system can be handled as zones where one zone can be down, another can be in operation and a third manually operated. Without degrading operation and safety or influencing each other's zones.

### Why is the AS-i Safety so good from a safety perspective?

The simple connection to a cable also applies to safety components. The risk of incorrect wiring is thereby minimized. Each safety node, i.e. safety product, has its own address on the AS-i bus along with a unique safety code.

The additional requirement for an AS-i system to cope with safety products is that there must be extra safe monitoring. The control ("Supervisor") does not need to be safe, but is complemented with a safety Monitor (however, safety PLC Pluto AS-i can act as both Supervisor and/or Monitor).

The advantage of safety within AS-i is that it is easy to introduce changes without significant costs compared to traditional safety systems that require new cable running from the electrical cabinet for each new protection. Moreover, experience shows that most safety systems need to be retrofitted to adapt the protection to suit the changes to production.

### Voltage and Communications

The AS-i network is maintained by a special AS-i power supply unit that generates a regulated DC output voltage between 29.5 and 31.6 V. This supplies voltage to the network nodes at the same time as communications are transmitted in a superimposed manner.

### Nodes

Safety nodes (maximum 31) and A/B-nodes (maximum 62) are connected to the AS-i for both inputs and outputs.



*The AS-interface makes it easy to connect and remove products to and from the AS-i bus.*

### Two-Wire Cable

The AS-i cable is a two-wire cable (2x1.5mm<sup>2</sup>) that is not shielded. Connection is made using piercing technology, where the cable housing is self-restoring if a connection is moved. The cable retains enclosure protection class IP67 in this way.

### Adaptation Devices

For the AS-i cable it is possible to connect the adaptation devices that act as a link between a component and the AS-i system. These adaptation devices are available as both safety nodes and nodes for non-safe products.

### Sensors with Integrated Safety Nodes

Some AS-i adapted components have nodes directly built into the product, for example, there is one safety node in the Smile AS-i Emergency Stop.

# AS-i Safety from ABB Jokab Safety

## The AS-i System

The AS-i cable can be connected to the safety products separately or through the adaptation device Urax. Some components have an integrated AS-i node and are connected via an M12 connection directly to the yellow AS-i cable. Traditional products without an integrated AS-i node need to be connected via the safety node Urax. In both cases, the highest level of safety is maintained.

The AS-i cable is powered by 30V DC power supply and connected to a special AS-i power supply unit. Some components have power requirements that are higher than the AS-i cable is able to supply. Therefore, there is also a black cable (AUX 24V DC) with secondary supply voltage that is able to supply more current.

## Possible Connections for a Complete System

- All our sensors for AS-i via Urax
- All Pluto PLCs, gateways and absolute sensors through Pluto's safety bus to the Pluto AS-i
- Operator panel via the programming port on Pluto
- Expansion relay for multiple outputs

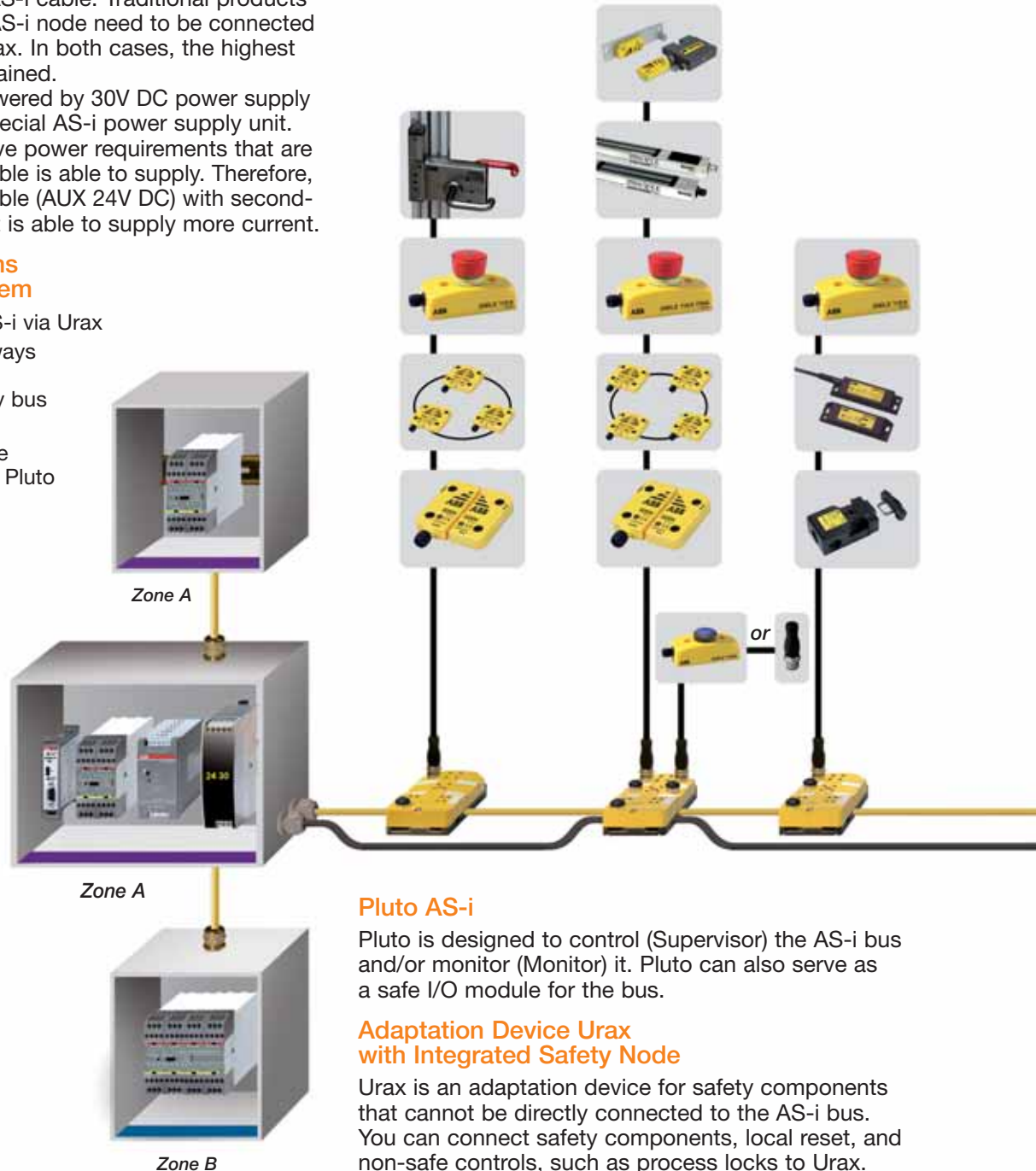

## Safety Level

Pluto, Urax and our other products with integrated safety nodes achieve up to safety level Cat. 4/PL e in compliance with EN ISO 13849-1.

## Pluto AS-i

Pluto is designed to control (Supervisor) the AS-i bus and/or monitor (Monitor) it. Pluto can also serve as a safe I/O module for the bus.

## Adaptation Device Urax with Integrated Safety Node

Urax is an adaptation device for safety components that cannot be directly connected to the AS-i bus. You can connect safety components, local reset, and non-safe controls, such as process locks to Urax. Urax is available in several versions, adapted to suit specific safety products.

## AS-interface An Intelligent Cable Running System

The field bus system AS-interface came to light in the 90s. The system was the result of a collaboration between several component manufacturers for machine control. The idea was a bus system at a component level where the goal was simplicity and flexibility. Since the system was launched, many new and innovative ideas have been added.

### Easy Connections to the AS-i Cable

Adaptation devices are clamped directly to the AS-i cable. Transition from the AS-i cable to M12 units is made via a T connector. Cable branches or extensions of the AS-i cable are made using a splitter box.

### Sensors with Integrated AS-i Safety Nodes

Some of our products can be ordered with integrated AS-i node. These are connected to the yellow cable with a M12 contact directly to the yellow AS-i cable via a screw terminal which is clamped to the cable. More information can be found under each product.

## AS-International Association

In 1991, the AS-International Association for organizational cohesion and marketing was founded. The AS-i association works in both an advisory and auditing capacity to ensure the AS-i standard is maintained.

The goal of the AS-i Association is that the AS-interface is to become a world standard for easy communication for components within the automation industry.

The distinguishing feature of the AS-interface is that data communication is mixed with the power supply. This is done in a simple two-wire cable. In 2001 safety was integrated in the AS-interface via the work group Safety at Work, which also includes ABB Jokab Safety.

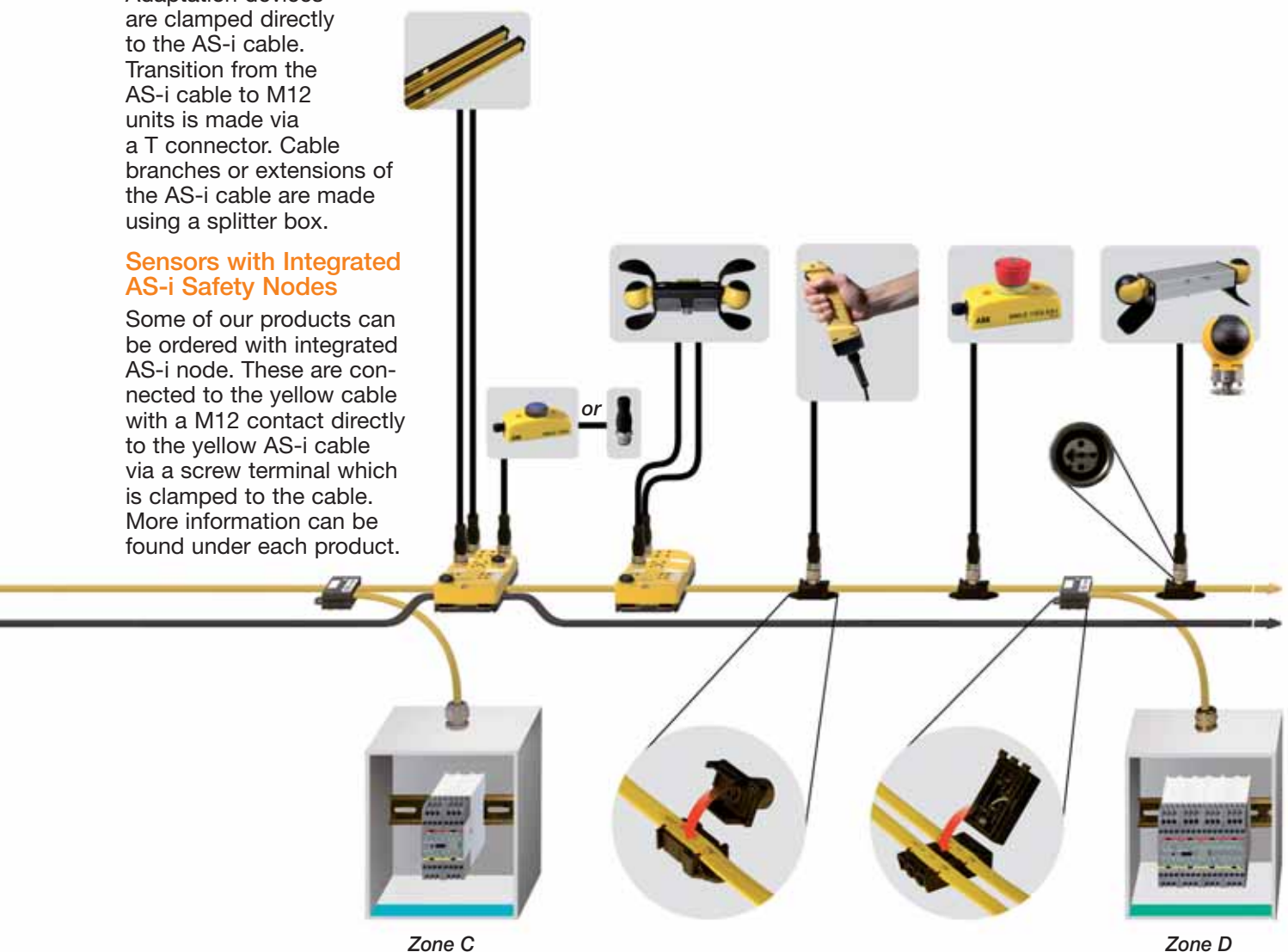

# Pluto AS-i Safety PLC

## A Safety PLC for AS-i Safety

Pluto AS-i is a Safety PLC designed for the AS-i Safety concept where all the safety components are connected to a single cable. Pluto AS-i has the same characteristics as a standard Pluto and works in the same way with the only difference being the AS-i bus. As with a standard Pluto, Pluto AS-i is in an All-Supervisor system with its own safety bus and is designed for dynamic and static safety circuits where inputs and other information are shared across the bus. Pluto AS-i also has a reduced number of failsafe inputs (I), failsafe relay and transistor outputs (Q) and terminals that are user-defined and serve as failsafe inputs or non-failsafe outputs (IQ).

For the AS-i bus, Pluto AS-i acts as a supervisor, monitor, or I/O controller. As a supervisor it controls and distributes all communication while it works as a monitor. In monitor mode, it listens to the bus and controls its safe outputs. As an I/O controller it serves as a subordinate node on the AS-i bus and communicates with another supervisor or monitor.

## Pluto AS-i is Available in Two Models

ABB Jokab Safety's Pluto AS-i is available in two different models. A smaller version, Pluto AS-i, and a larger model with a larger number of I/Os, Pluto B42 AS-i. Both models have a model-dependent number of I/Os. If more I/Os are necessary, you can connect Pluto AS-i to Pluto B16, B20 or B46 via the Pluto Safety bus.

## Pluto AS-i is Programmed using Pluto Manager

Programming Pluto AS-i is made easy using TÜV-reviewed software with ladder language and function blocks for various safety functions. The Pluto Manager software is also free to download from our website.



## Applications

- Control of safety products in dynamic and static circuits as well as in AS-i networks
- Control of electrically controlled actuators such as contactors, valves, motors
- Control of indicators and buttons

## Features

- AS-i interface where up to 31 safety nodes can be connected
- Dispersed constructions of machines
- Great flexibility
- Up to 10 sensors in series connected to one input
- Software Pluto Manager free of charge
- Handles conventional sensors and switches, as well as dynamical sensors
- Custom made safety bus
- Very large systems can be monitored by Pluto AS-i

## Approvals

TÜV Rheinland



## Pluto AS-i Technical Information

### Dynamic Signal

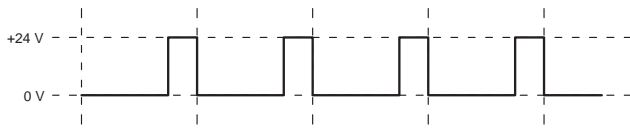

A dynamic signal makes it possible to achieve the highest level of safety with only one conductor. By transmitting a square wave and then evaluating the signal when it comes back to the controller you achieve the redundancy required. The signal is inverted once at each safety sensor (if the protection is OK) which makes it possible to detect short circuits across a sensor. When the signal switches between high (+24 V) and low (0V) it can be evaluated and tested about 200 times per second.

Pluto can generate three unique dynamic signals: A pulse, B pulse or C pulse. Short circuits between two different dynamic signals are detected whenever the signal that is created is different from the expected signal in Pluto. The kind of signal Pluto expects at the input terminal is determined in Pluto Manager (A, B or C pulse and if the signal should be inverted or not).

### Static Signal

Static signals (+24 V) can be connected to all inputs on Pluto. The kind of signal Pluto expects at the input terminal is determined in Pluto Manager. To achieve a two-channel structure according to EN ISO 13849-1 you need two inputs.

### OSSD-Signal

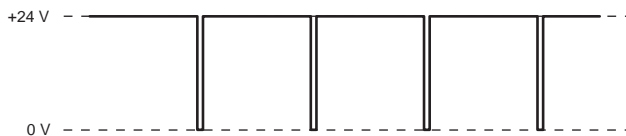

There are safety products with internal monitoring of dual OSSD signals (the device detects its own faults rather than Pluto doing this). From these devices, at least one of the two signals is connected to an I-input in Pluto, i.e. both signals must not be connected to the IQ-terminals. The terminal blocks are then configured in Pluto Manager to expect static inputs (OSSD signals are filtered internally in Pluto).

### IQ – Individual Failsafe Inputs and Non-Failsafe Outputs

The IQ terminals can be used either as individual failsafe input or non-failsafe output (e.g. for indicator light or status signal). The terminal blocks can also be used as both input and output simultaneously, which is useful for example for push buttons (input) with indicator light (output). This function is designed primarily for reset buttons to reduce the number of used terminal blocks on the controller.

### I - Individual Failsafe Inputs

All inputs are individually failsafe as each input is connected separately to both processors in Pluto. In order to maintain the redundancy required for two-channel structure and the highest level of safety, the dynamic signal must be used. When using static signals, two inputs must be used to achieve two-channel structure. The expected signal to the terminals blocks is determined in Pluto Manager (static or dynamic signal).

### Q - Individual Failsafe Outputs

All Q outputs are individually safe and are independently programmable. There are both relay outputs and transistor outputs.

### Transistor Outputs (-24 VDC)

The transistor outputs are just like the relay outputs—that is, individually safe and independently programmable. However, the transistor outputs are different from the relay outputs as the internal connection provides the nominal output voltage -24 VDC, which is primarily intended for controlling electromechanical components such as contactors and valves. As -24 VDC is a unique signal in the majority of electrical cabinets and the fact that the output is monitored by Pluto, short circuits with other potentials can be detected right away.

### Pluto-Bus

The Pluto-bus is a CAN-bus with its own safety protocol. The bus cable can be up to 600 m long at the minimum bus speed, and up to 150 m at 400 kb/s. The bus can be both extended and connected to other types of buses through gateways.

### AS-i Bus

The AS-i bus is also a safe bus where safety is based on an alternating code table. The bus can be up to 500 m in length provided that the bus supervisor is placed in the middle of the loop. Each AS-i branch should not be longer than 100 m. The loop can be extended by using repeaters. However, there should not be more than two repeaters attached in series due to time constraints.

All safety components that are connected to the AS-i loop take a complete address and are interpreted as subordinates. The AS-i bus can handle 31 different addresses where each address can be divided into an A and B subordinate for non safety I/O. A separate power supply unit with about 30V DC is required for the AS-i bus.

## Pluto Manager and IDFIX

For more information, see page 2:8

# Pluto AS-i Safety

A Pluto AS-i can be used in three ways — as Safety Supervisor, Safety Monitor or as Safety I/O

## 1. Pluto as Safety Supervisor\*

The supervisor distributes and controls communication on the AS-i bus and acts simultaneously as Safety Monitor.

## 2. Pluto as Safety Monitor\*

The monitor listens to what is happening on the AS-i bus and controls the safe outputs.

## 3. Pluto as Safety I/O\*

Multiple safe inputs and/or outputs are controlled and communicate with a safe supervisor or monitor across the AS-i bus.

**\*Note:** Whether Pluto is used as a Supervisor, Monitor or I/O it can simultaneously control and monitor the safety of a machine.

## How large can you build the system?

From a technical aspect there are no constraints on the size of the system you can build. A Pluto PLC can, in addition to processing a complete AS-i bus, communicate with another Pluto either through a Pluto safety bus or through the AS-i bus.

Through Pluto's safety bus, each Pluto can be a party to the I/Os of others and a total of 32 Plutos can be linked in this way. If two Plutos are connected to each other via the AS-i bus, each Pluto can be connected to 31 other Plutos.

Using Gateways the system can be expanded further to other bus systems for information exchange.

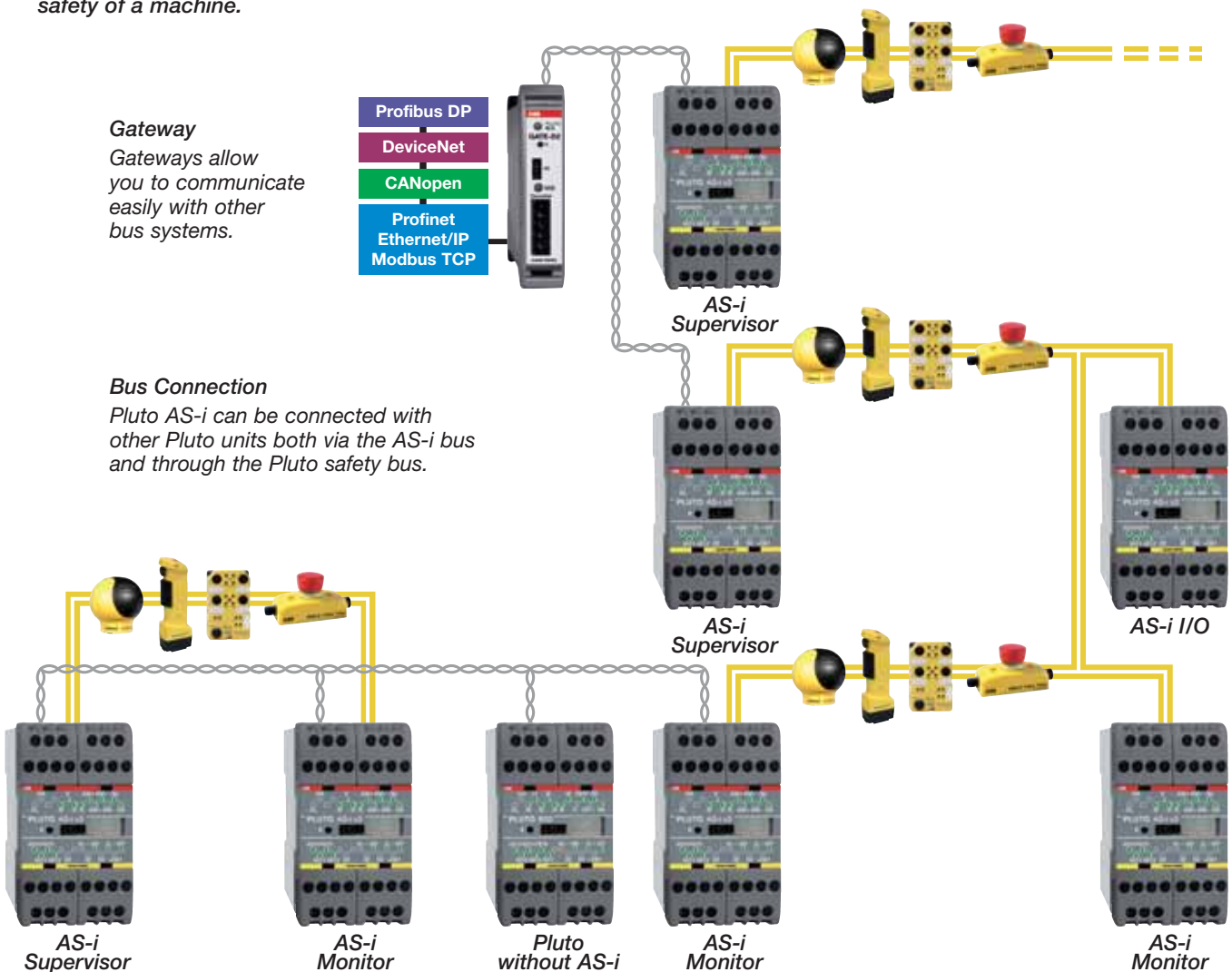

## AS-i Technical Data - General

Manufacturer	ABB AB/Jokab Safety, Sweden	Pluto-bus Max number of Pluto on the bus Bus type Bus speeds	32 CAN 100, 125, 200, 250, 400, 500, 800, 1,000 kb/s Up to 600 m; 150 m at 400kb/s
Color	Grey		
Operating voltage	24VDC ±15 %	Bus cable length	Up to 600 m; 150 m at 400kb/s
Assembly	35 mm DIN busbar		
Electrical insulation	Category II according to IEC 61010-1	AS-i bus Supervisor profile Number of supordinate units Bus operation mode	M2 31/62* Supervisor Safety monitor Safety monitor, subordinate and safe I/O module
Safety level EN 954-1 EN ISO 13849-1 EN 61508 EN 62061	Cat. 4 PL e/cat. 4 SIL 3 SIL 3	Bus cable length	Up to 500 m 100 m between each repeater
PFH <sub>d</sub> Relay output Transistor output	2.00×10 <sup>-9</sup> 1.50×10 <sup>-9</sup>		
Failsafe inputs I & IQ Type	+24 V (for PNP sensors), IQ is also configurable as non-safe outputs	Temperature Ambient temperature Storage and transport	-10°C - +50°C -25°C - +55°C
Current at 24V Max surge	5.1 mA 27V continuous	Reaction times Dyn.A or static input to relay output Dyn.A or static input to transistor output Dyn.B or Dyn.C input to relay output Dyn.B or Dyn.C input to transistor output Setting "NoFilt"	<20.5 ms + prog. execution time <16.5 ms + prog. execution time <23 ms + prog. execution time <19 ms + prog. execution time 5 ms shorter reaction time on I & IQ inputs <33 ms + prog. execution time <29 ms + prog. execution time
Failsafe transistor outputs Q Output voltage Tolerance for output voltage Max current	-24 VDC Supply voltage - 1.5 V at 800 mA 800 mA	Additional reaction times Bus between Pluto units Bus between Pluto units following fault	10 ms 10–40 ms
Failsafe relay outputs Q Max voltage Max current	250 VAC 1.5 A	Enclosure protection class Enclosure Terminal blocks	IP 40, IEC 60 529 IP 20, IEC 60 529
Non-failsafe outputs IQ Type	Transistor +24 V, PNP "open collector" is also configurable as failsafe inputs		
Max current/output	800 mA		
Indicator Input/output LED Display	1 per I/O (green) 7-segments, two characters		

\* Each address can have an A and B node each containing four inputs and four outputs. The number of slaves can thereby be increased to 62.

## Pluto AS-i Type-Specific Technical Data

The connection block is removable without having to disconnect any cables. The units are assembled with a gap of at least 5 mm.

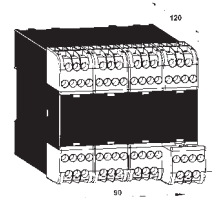
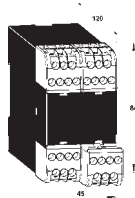

	Pluto AS-i AS-i bus	Pluto B42 AS-i AS-i bus
Ordering information	see page 03:23	see page 03:23
Failsafe inputs	4 ea (I0..I3)	20 ea (I0..I3, I30..I47)
Failsafe inputs or non-failsafe outputs	4 ea (IQ10..IQ13) Maximum total load 2A	16 ea (IQ10..IQ27) Maximum total load 2A
Analogue inputs	4 ea (IQ10..IQ13) 0..27V	3 ea (I1..I3) 0..27V
Failsafe relay outputs	2 ea (Q0..Q1)	4 ea (Q0..Q1 & Q4..Q5)
Failsafe transistor outputs	2 ea (Q2..Q3)	2 ea (Q2..Q3)
Current monitoring	-	-
Pluto-bus	•	•
AS-i bus	•	•
Internal current consumption	100 mA	150 mA
Recommended external fuse	6A	10A
Dimensions (wxhxd)	45 x 84 x 118 mm	90 x 84 x 118 mm

## I/O Pluto AS-i

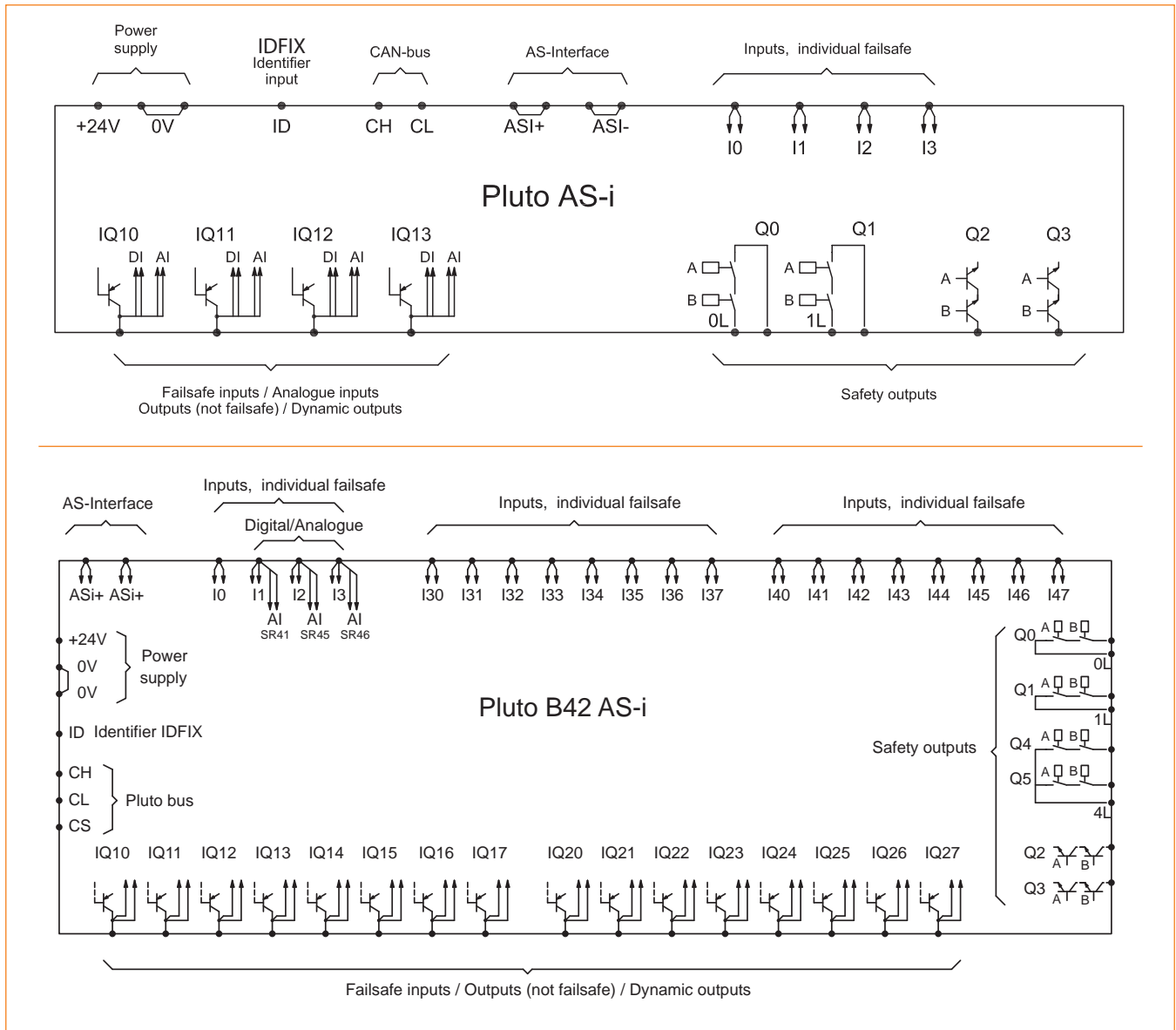

**ID:** Connection for identifier, which has a unique ID number that can be read by the system.

**I..** Safety inputs (24 VDC) that are individually secure. This means that you can achieve the highest level of safety with you use ABB Jokab Safety's dynamic safety components. Otherwise two inputs are required for each safety function.

**IQ..** I/O that can be used as safety inputs or signal outputs, e.g. for indicating or controlling functions that are not safety-related. For IQ.. as safety inputs, refer to I..

**Q0, Q1:** Failsafe relay outputs that are individually failsafe and independently programmable.

**Q2, Q3:** Failsafe transistor outputs (-24 VDC) that are individually failsafe and independently programmable. Designed for electro-mechanical components such as contactors and valves.

**Q4, Q5:** Failsafe relay outputs with common potential that are individually failsafe and independently programmable.



# Why should I use the Safety Node URAX?

- ...to connect safety sensors to AS-i Safety
- ...to connect non-safe products to AS-i Safety
- ...to maintain the highest level of safety PL e in compliance with EN ISO 13849-1

The URAX Safety Node has Safety Inputs for Sensors and Reset Buttons—and Outputs such as Process Locks

URAX safety node is available in several versions, and is designed for a variety of safety components. URAX has the capability to connect multiple sensors in series to the highest level of safety PL e in compliance with EN ISO 13849-1.



## Overview URAX

	URAX A1	URAX A1R	URAX B1R	URAX C1	URAX C1R	URAX D1R	URAX E1	FLEX 4A	FLEX 4B
Dynamic sensor (Eden, Tina)	3	3	10						
Two-channel sensors				•	•				
Sensors with OSSD Signals						•			
Two-hand station							•		
Local reset function		•	•		•	•			
External power source			•			•			•
Non-safe outputs	1	1	3			3	3	4	4

# Safety Node URAX-A1/A1R

## Adaptation Device for Dynamic Sensors for AS-i

URAX-A1/A1R is a safety node for the AS-i bus, where it is possible to connect up to three dynamic sensors, such as Eden, in series in compliance with PL e EN ISO 13849-1.

Switches adapted to dynamic sensors such as Smile Tina can also be connected to the safety circuit.

URAX-A1/A1R also has an output for non-safe control, where it is possible to control non-safety critical equipment such as process locks. URAX-A1R has an additional feature that provides local reset button (R) with LED indicator.

The dynamic safety sensors are controlled by URAX over one hundred times per second which gives a high level of safety.

URAX-A1/A1R has LED indication for the dynamic loop and can be addressed on the bus via the ADDR contact.



### Application

- Adapts dynamic sensors to the AS-i bus

### Features

- Enables dynamic sensors on the AS-i bus
- Multiple sensors in series with maintained safety level
- Possibility of local reset
- Outputs of non-safe control, e.g. process locks

### Approvals

TÜV Nord CE

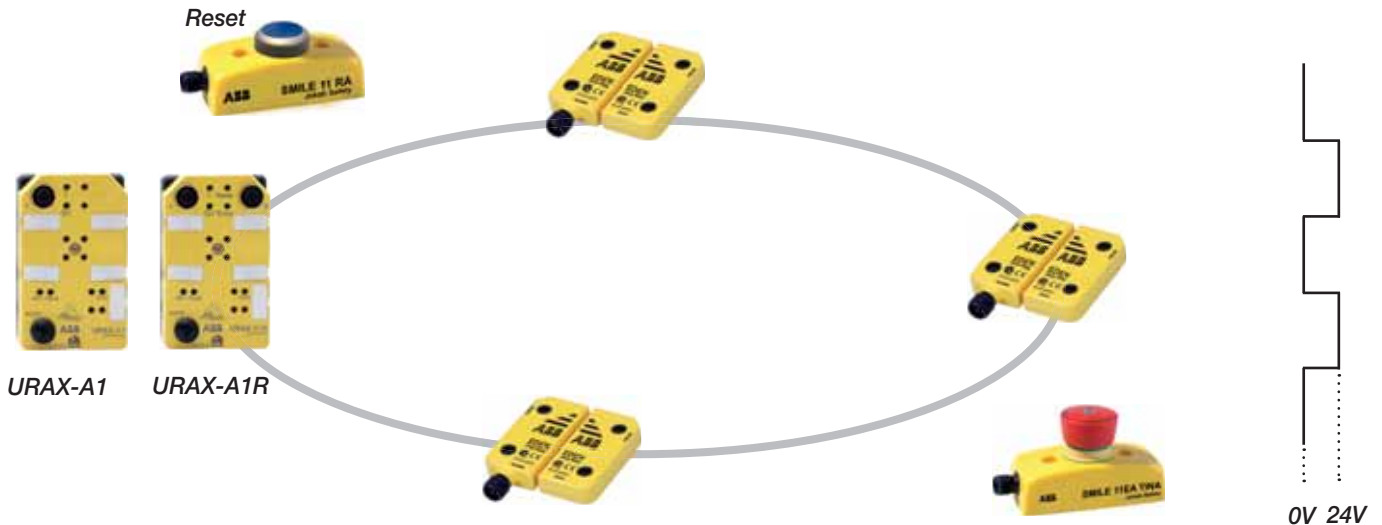

## URAX-A1/A1R Technical Data

Manufacturer	ABB AB/Jokab Safety, Sweden
Ordering information	see page 03:23
Color	Yellow and black
Weight	155 g
AS-i data AS-i profile URAX-A1/A1R Addressing Subordinate address upon delivery	S-7.B.E Jack plug 0
Voltage supply Voltage Insulation Total current consumption Current limit for the outputs in total	AS-i yellow cable, 30 V DC Tolerance 26.5 – 31.6 V DC 0 V is common with AS-i and must not be connected to the protective earth (the AS-i voltage is floating) <260 mA (own consumption, sensor and outputs) 180 mA (sensors, outputs and reset indicator)
Output (non-safe) Output voltage Current	24-28V DC at nominal AS-i voltage, 30V Depending on load (see total current consumption)
Reaction time Reaction time (off)* Reaction time including Eden sensor (normal) Reaction time including Eden sensor (worst case)	12 ms (excluding sensors and other peripheral components) <20 ms <34 ms

Sensor info Number of Eden sensors (max) Cable to sensor, total length	3 <30 m
Temperature (ambient)	-25...+65°C
Enclosure Enclosure protection class	IP67
Safety/Harmonized standards IEC/EN 61508-1..7 EN 62061 EN ISO 13849-1 EN 954-1 Certification	SIL3, PFD <sub>avr</sub> : 1.5x10 <sup>-4</sup> , PFH: 1.7x10 <sup>-9</sup> , Share of SIL3: 15 % SIL3 Performance Level PL e, Category 4 MTTFd: high Category 4

**Note:** The reaction time refers only to the URAX device. In calculating the total reaction time, all the component parts in the safety chain must be taken into account.

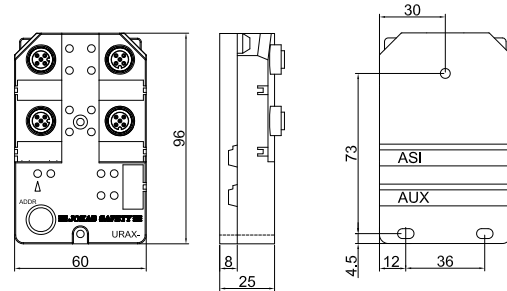

## Connections for URAX-A1 and A1R

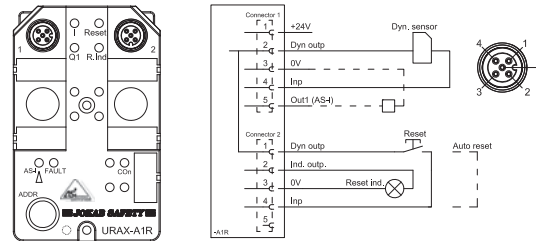
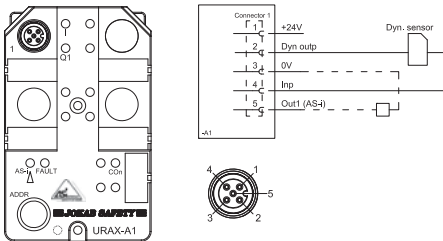

### The Concept of Dynamic Signal

The concept is a safety circuit that is based on a single-channel dynamic signal. The dynamic signal, along with the adapted sensor, makes it possible to build large systems with sensors in series while maintaining the highest level of safety. The safety principle is based on each sensor inverting the signal, making it possible to detect faults such as short circuits and defective sensors.

### Odd or Even Number of Sensors on URAX

The dynamic signal is generated in URAX and goes out to the sensors and then back again. The fact that the number of sensors may vary and that each sensor inverts the signal, make it necessary for URAX-A1/A1R to be configured so that it takes into account whether it is an odd or even number of sensors that are connected to the safety loop. This is done via the AS-i node parameter settings.

### Non-Safe Outputs

URAX-A1/A1R is fitted with a non-safe output. This can be used for diverse control or indicators and is controlled directly from the AS-i supervisor. The output is located on the same contact as the safety sensor, i.e. on contact 1 and controlled on pin 5. For example, you can connect a Dalton or Knox to this contact.

### Reset

URAX-A1R has an input for local reset on contact 2 that can be configured using parameter settings for either automatic or manual reset.

**Auto reset:** If auto reset has been selected, pins 1-4 on contact 2 must be bridged.

**Manual reset:** If manual reset has been selected, the reset input must be switched on and off within 2 seconds in order for URAX to be enabled (generate safety code).

# Safety Node URAX-B1R

## Adaptation Device for Dynamic Sensors for AS-i

URAX-B1R is a safety node for the AS-i bus, where it is possible to connect up to ten dynamic sensors, such as Eden, in series in compliance with PL e EN ISO 13849-1.

Switches designed for dynamic safety circuit, such as Smile Tina, can also be connected.

URAX-B1R also has three outputs for non-safe control. Through these it is possible to control non-safety critical equipment such as the process lock Magne.

URAX-B1R will be supplied with an auxiliary power supply (AUX), which means that more power-consuming equipment can be connected to the node.

An additional feature is that it is possible to connect a local reset button (R) with LED indicator.

The dynamic safety sensors are controlled by URAX over one hundred times per second which gives a high level of safety.

URAX-B1R has LED indication for the dynamic loop and can be addressed on the bus via the ADDR contact.



### Application

- Adapts dynamic sensors with higher current requirements to the AS-i bus

### Features

- Enables dynamic sensors on the AS-i bus
- Up to 10 sensors connected in series while maintaining the highest level of safety
- Possibility of local reset
- Outputs of non-safe control, e.g. process locks

### Approvals

TÜV Nord

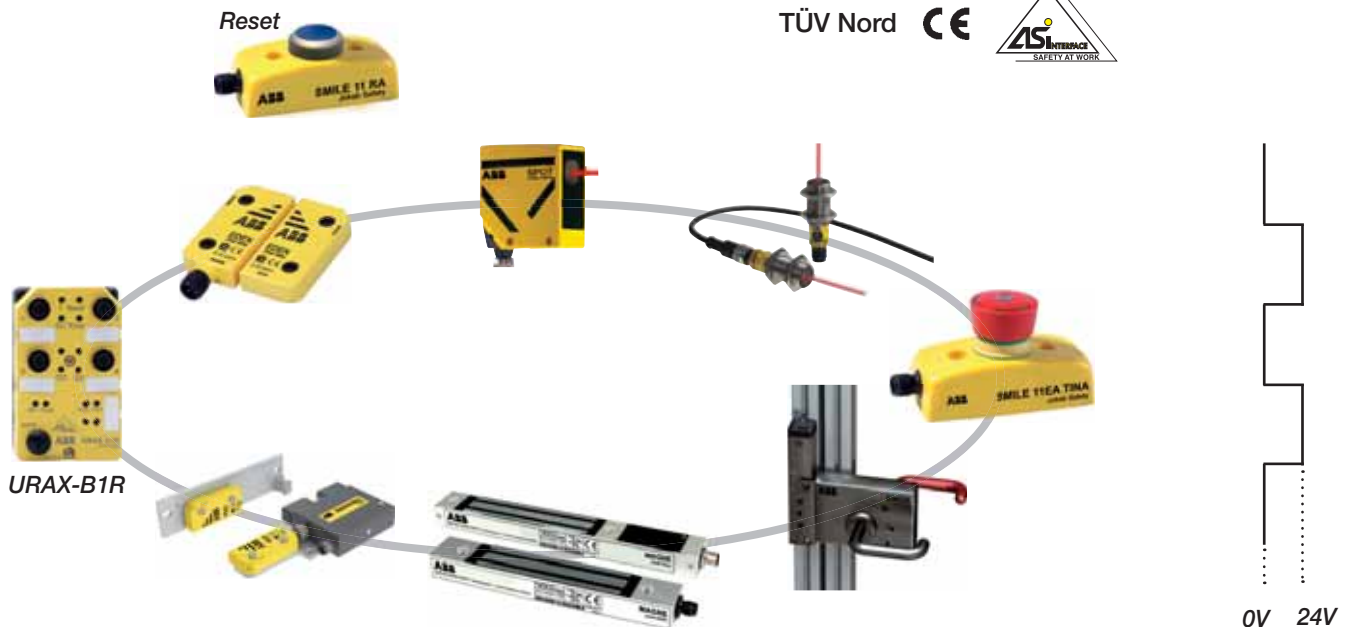

## URAX-B1R Technical Data

<b>Manufacturer</b>	ABB AB/Jokab Safety, Sweden
<b>Ordering information</b>	see page 03:23
<b>Color</b>	Yellow and black
<b>Weight</b>	155 g
<b>AS-i data</b> AS-i profile URAX-B1R Addressing Subordinate address upon delivery	S-7.B.E Jack plug 0
<b>Voltage supply</b> Voltage AS-i (Yellow cable)  Voltage AUX (Black cable) Insulation	30 V DC. Tolerance 26.5 – 31.6 V DC.  24 V DC (±15 %) 0 V is common with AS-i and must not be connected to the protective earth (the AS-i voltage is floating)
Current limit (+24 V) Total current consumption AS-i	700 mA <30 mA
<b>Output (non-safe)</b> Output voltage Current	24V DC (AUX) 700 mA
<b>Reaction time</b> Reaction time (off)*  Reaction time including Eden sensor (normal) Reaction time including Eden sensor (worst case)	12 ms (excluding sensors and other peripheral components)  <20 ms <34 ms

<b>Sensor info</b> Number of Eden sensors (max) Cable to sensor, total length	10 <30 m
<b>Temperature (ambient)</b>	-25...+65°C
<b>Enclosure</b> Enclosure protection class	IP67
<b>Safety/Harmonized standards</b> IEC/EN 61508-1..7  EN 62061 EN ISO 13849-1  EN 954-1 Certification	SIL3, PFD <sub>avr</sub> : 1.5x10 <sup>-4</sup> , PFH: 1.7x10 <sup>-9</sup> , Share of SIL3: 15%  SIL3 Performance Level PL e, Category 4 MTTFd: high Category 4

*Note: The reaction time refers only to the URAX device. In calculating the total reaction time, all the component parts in the safety chain must be taken into account.*

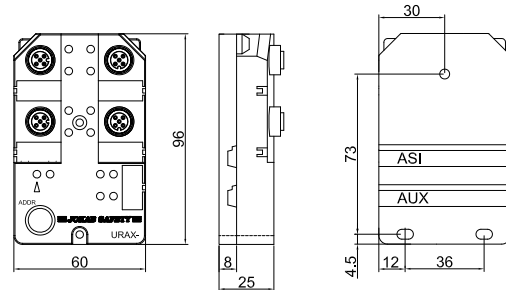

## Connections for URAX-B1R

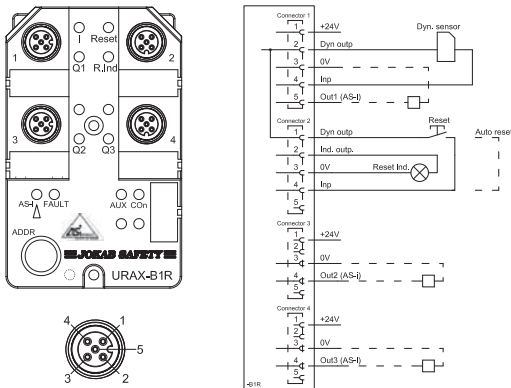

### The Concept of Dynamic Signal

The concept is a safety circuit that is based on a single channel dynamic signal. The dynamic signal, along with the adapted sensor, makes it possible to build large systems with sensors in series while maintaining the highest level of safety. The safety principle is based on each sensor inverting the signal, making it possible to detect faults such as short circuits and defective sensors.

### Odd or even number of sensors on URAX

The dynamic signal is generated in URAX and goes out to the sensors and then back again. The fact that the number of sensors may vary and that each sensor

inverts the signal, make it necessary for URAX-B1R to be configured so that it takes into account whether it is an odd or even number of sensors that are connected to the safety loop. This is done via the AS-i node parameter settings.

### Non-Safe Outputs

URAX-B1R is fitted with three non-safe outputs. These can be used for diverse controls or indicators and are controlled directly from the AS-i supervisor.

Output 1 is located on the same contact as the safety sensor, i.e. contact 1 and controlled on pin 5. For example, you can then connect a Dalton or Knox to this contact. Outputs 2 and 3 have non-safe control on pin 4 of contact 3 and 4 respectively.

### Reset

URAX-B1R has an input for local reset on contact 2 that, with parameter settings, can be configured for either automatic or manual reset.

**Auto reset:** If auto reset has been selected, pins 1-4 on contact 2 must be bridged.

**Manual reset:** If manual reset has been selected, the reset input must be switched on and off within 2 seconds in order for URAX to be enabled (generate safety code).

# Safety Node URAX-C1/C1R

## Adaptation Device for Sensors with Two-Channel Structure on AS-i

URAX-C1/C1R is a safety node for the AS-i bus that enables the connection of switches or emergency stops. Connections can be made so that URAX-C1/C1R, together with the switch, comply with PL e EN ISO 13849-1.

URAX-C1/C1R is configurable depending on the switch you prefer to use. The safety node's two-channel structure works with both NO+NO and NO+NC contacts.

URAX-C1R has an additional feature that allows the connection of a local reset button (R) with LED indicator.

The safety switches' contacts are controlled by URAX each time they are actuated, for example when a door is opened and closed.

URAX-C1/C1R has LED indicators for all channels and can be addressed on the bus via the ADDR contact.



### Application

- Adapts switches/E-stop with two-channel structure to the AS-i bus

### Features

- Suitable for both normally open (NO) and normally closed (NC) contacts
- Possibility of local reset

### Approvals

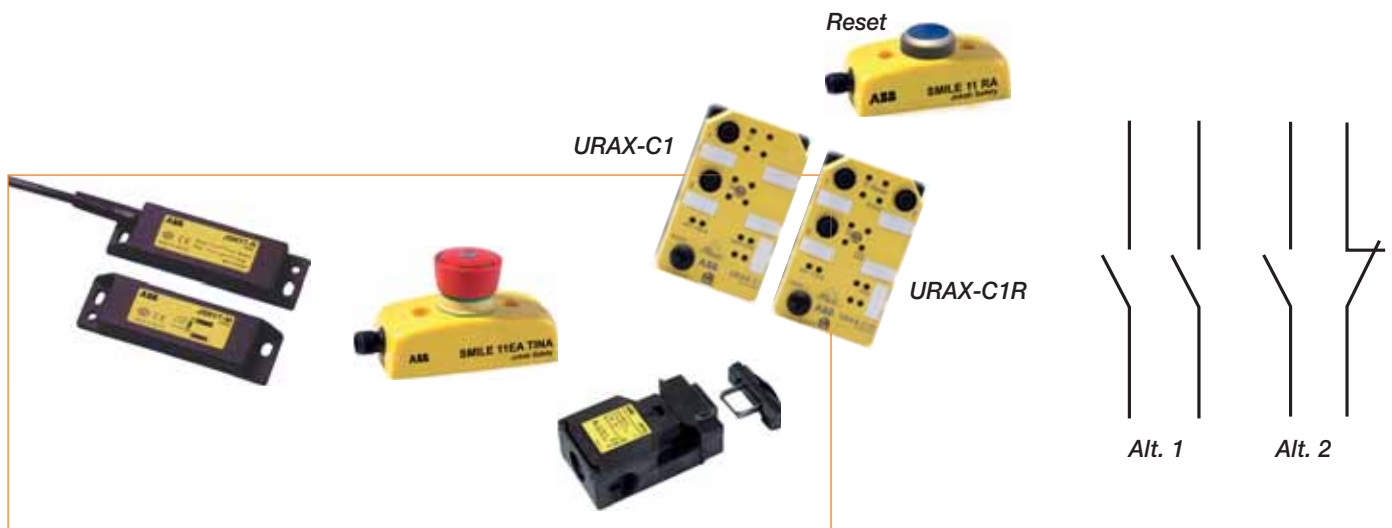

## URAX-C1 and C1R Technical Data

Manufacturer	ABB AB/Jokab Safety, Sweden
ordering information	see page 03:23
Color	Yellow and black
Weight	150 g
AS-i data	
AS-i profile URAX-C1/C1R	S-0.B.0
Addressing	Jack plug
Subordinate address upon delivery	0
Voltage supply	
Voltage	AS-i yellow cable, 30 V DC (26.5 – 31.6)
Total current consumption AS-i	<150 mA
Reaction time	
Reaction time (off)*	12 ms (excluding sensors and other peripheral components)
Temperature (ambient)	-25...+65°C
Enclosure	
Enclosure protection class	IP67

Safety/Harmonized standards IEC/EN 61508-1..7	SIL3, PFD <sub>avr</sub> : 1.5x10 <sup>-4</sup> , PFH: 1.7x10 <sup>-9</sup> , Share of SIL3: 15%
EN 62061	SIL3
EN ISO 13849-1	Performance Level PL <sub>e</sub> , Category 4 MTTFd: high
EN 954-1 Certification	Category 4

*Note: The reaction time refers only to the URAX device. In calculating the total reaction time, all the component parts in the safety chain must be taken into account.*

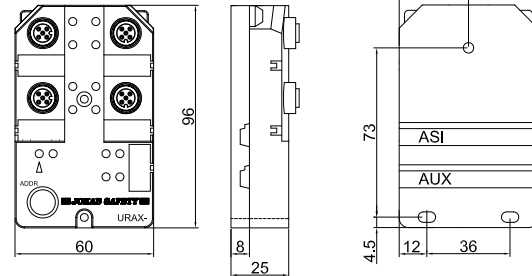

## Connections for URAX-C1 and C1R

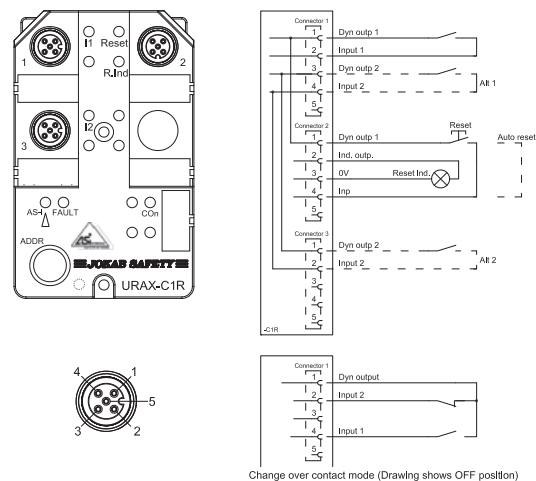
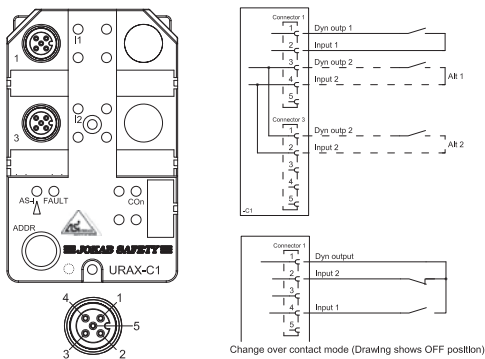

### Two-Channel Input

URAX-C1 is designed for safety components with two-channel switches. The channels are supplied with individual dynamic signals, which enables the detection of short circuits between channels. It is possible to either connect a two-channel component exclusively to contact 1, or to connect two separate single-channel components to contact 1 and contact 3.

### Contact Function, NO+NO/NO+NC

URAX-C1/C1R can work in either of the two operating modes—NO + NO, with two closing contacts, or NO+NC with one closing and one opening contact. This selection is made using parameter settings.

### Filtration of Contact Bounce

URAX-C1R has a function to filter contact bounce—“debounce”—which is active irrespective of the parameter settings. After both channels (I1 and I2) have been enabled, it is accepted for 1 second that they turn off/on. In other words, the channel monitoring is disabled during the first second after being enabled.

### Concurrency Requirements

URAX-C1R also has the capability of monitoring concurrency requirements. Both channels must then change status within 2 seconds. This setting is made via the node's parametrization.

### Reset

URAX-C1R has an input for local reset on contact 2 that can be configured using parameter settings for either automatic or manual reset.

**Auto reset:** If auto reset has been selected, pins 1-4 on contact 2 must be bridged.

**Manual reset:** If manual reset has been selected, the reset input switch must be switched on and off within 2 seconds in order for URAX to be enabled (generate safety code).

# Safety Node URAX-D1R

## Adaptation Device for Sensors with Transistor Outputs (OSSD) for the AS-i Bus

URAX-D1R is a two-channel safety input subordinate for the AS-i bus that enables the connection of different protection with OSSD outputs. Examples of components of this type are light curtains, light grids and scanners. Connections can be made so that the safety node, together with the sensor, comply with PL e EN ISO 13849-1.

The safety node is also fitted with three non-safe outputs.

URAX-D1R has an additional feature that allows the connection of a local reset button (R) with LED indicator.

URAX-D1R has LED indicators for all OSSD outputs and can be addressed on the bus via the ADDR contact.



## Application

- Adapts safety products with transistor outputs (OSSD) to the AS-i bus

## Features

- Handles safety products with transistor outputs (OSSD)
- Monitors test pulses
- Possibility of local reset
- Outputs of non-safe control

## Approvals

TÜV Nord





## URAX-D1R Technical Data

Manufacturer	ABB AB/Jokab Safety, Sweden
Ordering information	see page 03:23
Color	Yellow and black
Weight	150 g
AS-i data	
AS-i profile URAX-C1/C1R	S-0.B.0
Addressing	Jack plug
Subordinate address upon delivery	0
Voltage supply	
Voltage	AS-i yellow cable, 30 V DC (26.5 – 31.6)
Total current consumption AS-i	<150 mA
Output (non-safe)	
Output voltage	24V DC (AUX)
Current	700 mA
Reaction time	
Reaction time (off)*	12 ms (excluding sensors and other peripheral components)
Temperature (ambient)	-25...+65°C
Enclosure	
Enclosure protection class	IP67

Safety/Harmonized standards IEC/EN 61508-1..7	SIL3, PFD <sub>avr</sub> : 1.5x10 <sup>-4</sup> , PFH: 1.7x10 <sup>-9</sup> , Share of SIL3: 15 %
EN 62061	SIL3
EN ISO 13849-1	Performance Level PL <sub>e</sub> , Category 4 MTTFd: high
EN 954-1 Certification	Category 4

*Note: The reaction time refers only to the URAX device. In calculating the total reaction time, all the component parts in the safety chain must be taken into account.*

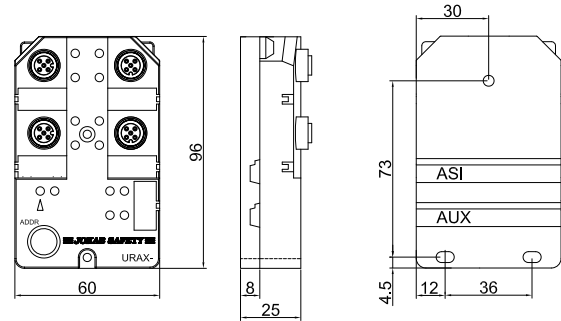

## Connections for URAX-D1R

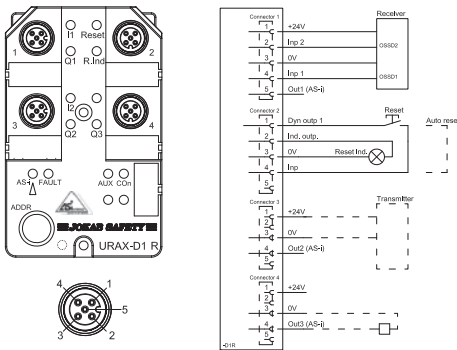

### Monitoring of Short Circuits (Test Pulses)

The safety device that connects to URAX-D1R must be capable of detecting both short circuits between the channels and short circuits to the supply voltage. These types of faults are not detected by URAX! The most common way for the safety device to detect this is by transmitting test pulses on the outputs (OSSD).

### Detection of Test Pulses

You can configure URAX-D1R to detect whether the test pulses are transmitted from the connected device or not (see Table, "Parameter settings and safety codes"). If Test Pulse Detection is selected, URAX will be disabled if these test pulses are missing. This feature is a safeguard against fraud.

### Non-Safe Outputs

URAX-D1R is fitted with 3 non-safe outputs. These can be used for diverse controls or indicators and are controlled directly from the AS-i supervisor.

Output 1 is located on the same contact as the safety sensor, i.e. contact 1 and controlled on pin 5. For example, you can then connect a Dalton or Knox to this contact. Outputs 2 and 3 have non-safe control on pin 4 of contact 3 and 4 respectively.

### Reset

URAX-D1R has an input for local reset on contact 2 that, with parameter settings, can be configured for either automatic or manual reset. (See table, parameter settings and safety codes.)

*Auto reset:* If auto reset has been selected, pins 1-4 on contact 2 must be bridged.

*Manual reset:* If manual reset has been selected, the reset input must be switched on and off within 2 seconds in order for URAX to be enabled (generate safety code).

# Safety Node URAX-E1

## Adaptation Device for Two-Hand Stations for the AS-i Bus

URAX-E1 is a dual channel safety input subordinate to the AS-i bus, which is designed to connect the two-hand station in compliance with EN 574 model IIIC. Connections can be made so that the safety node with two-hand station complies with PL e EN ISO 13849-1.

URAX-E1 has LED indicators for all channels and can be addressed on the bus via the ADDR contact.



### Application

- Adapts two-hand devices to the AS-i bus

### Features

- Handles two-hand devices with two channels
- Simultaneity requirement

### Approvals

TÜV Nord

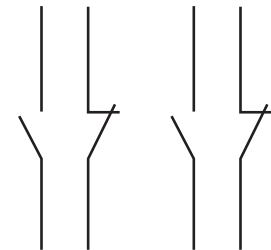

## URAX-E1 Technical Data

Manufacturer	ABB AB/Jokab Safety, Sweden
Ordering information	see page 03:23
Color	Yellow and black
Weight	150 g
AS-i data	
AS-i profile URAX-C1/C1R	S-0.B.0
Addressing	Jack contact
Subordinate address upon delivery	0
Voltage supply	
Voltage	AS-i yellow cable, 30 V DC (26.5 – 31.6)
Total current consumption AS-i	<150 mA
Output (non-safe)	
Output voltage	24V DC (AUX)
Current	700 mA
Reaction time	
Reaction time (off)*	12 ms (excluding sensors and other peripheral components)
Temperature (ambient)	-25...+65°C
Enclosure	
Enclosure protection class	IP67

Safety/Harmonized standards IEC/EN 61508-1..7	SIL3, PFDavr: 1.5x10 <sup>-4</sup> , PFH: 1.7x10 <sup>-9</sup> , Share of SIL3: 15 %
EN 62061	SIL3
EN ISO 13849-1	Performance Level PL <sub>e</sub> , Category 4 MTTFd: high
EN 954-1 Certification	Category 4

*Note: The reaction time refers only to the URAX device. In calculating the total reaction time, all the component parts in the safety chain must be taken into account.*

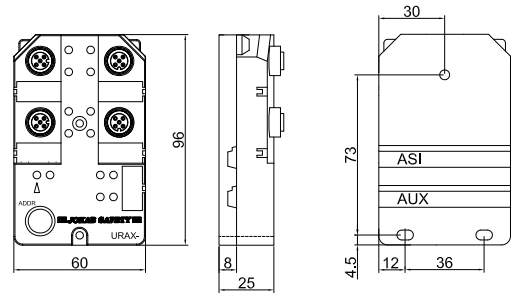

## Connections for URAX-E1

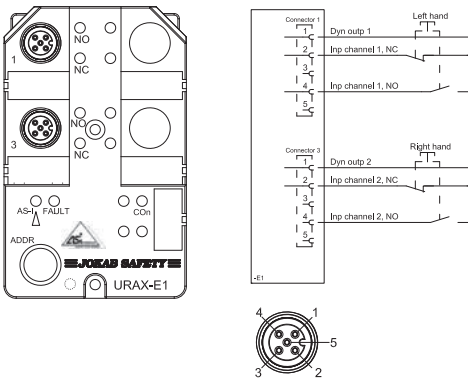

### Inputs for Two-Hand Stations

URAX-E1 has two inputs for each hand, one for closing and one for opening contact. For safe activation—or generating safety code—all four inputs are required to be enabled within 0.5 seconds. All inputs are monitored, and if URAX is disabled—or stops generating safety code—this requires that all four inputs are disabled before a restart is possible.

*Note: "Open" condition for a opening (NC) contact is closed contact, and "Open" condition for a closing (NO) contact is open contact.*

# Non-Safe Node FLEX 4A/4B

## Adaptation Device for Non-Safe Components for the AS-i Bus

Through four inputs and outputs, components such as light towers or keypads are connected and controlled from the supervisor on the AS-i bus. FLEX is available in models 4A and 4B.

The difference is that model 4B is adapted for external power supply—700mA per connection.

FLEX has LED indicators for all inputs and outputs and can be addressed on the bus via the ADDR contact.



### Application

- Adapts non-safe products to the AS-i bus

### Features

- 4 in and outputs to the AS-i bus
- Possibility of external power source
- LED indication

### Approvals







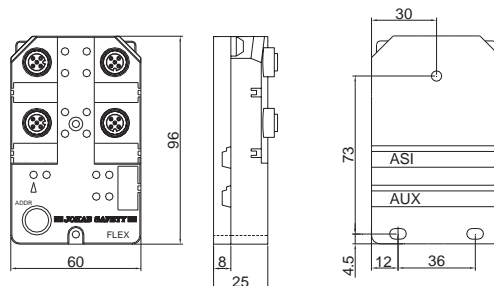

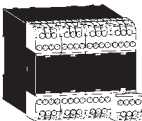

## FLEX Technical Data

Manufacturer	ABB AB/Jokab Safety, Sweden
Ordering information	see page 03:23
Color	Grey and black
Weight	150 g
AS-i data	
AS-i profile	S-7.A.E
Addressing	M12 contact
Subordinate address upon delivery	0
Voltage supply	
Voltage	FLEX-4A: AS-i yellow cable, 30.5 VDC (26.5 to 31.6 VDC) FLEX-4B: AS-i yellow cable, 30.5 VDC (26.5 to 31.6 VDC)
Total current consumption AS-i	FLEX-4A: Total max 185 mA (unit + connected units) FLEX-4B: Max 700 mA per pin, total max 2.8 A FLEX-4A/B (unit): 10–85 mA
Reaction time	
Reaction time (off)*	FLEX-4 separate: 5 ms FLEX-4 with AS-i bus: <10 ms
Temperature (ambient)	–25...+65°C
Enclosure	
Enclosure protection class	IP67



## Component List - AS-i Safety

Designation	Ordering Information	Description
Pluto AS-i 	2TLA020070R1100	Safety PLC with 4 failsafe inputs and 4 non-failsafe outputs/failsafe inputs and 2 individual failsafe relay outputs and 2 individual failsafe transistor outputs. For use with Pluto safe bus and/or AS-i Safe Bus (supervisor or monitor).
Pluto B42 AS-i 	2TLA020070R1400	Safety PLC with 20 failsafe inputs and 16 non-failsafe outputs/failsafe inputs and 4 individual failsafe relay outputs and 2 individual failsafe transistor outputs. For use with PLC to safe bus and/or AS-i Safe Bus (supervisor or monitor).
URAX-A1 	2TLA020072R0000	AS-i connection block for use with up to 3 dynamic sensors such as Eden + 1 non-safe output.
URAX-A1R 	2TLA020072R0100	AS-i connection block for use with up to 3 dynamic sensors such as Eden + 1 non-safe output. Local reset function available.
URAX-B1R 	2TLA020072R0200	AS-i connection block for use with up to 10 dynamic sensors such as Eden + 3 non-safe outputs. Local reset function available. Auxiliary power required.
URAX-C1 	2TLA020072R0300	AS-i connection block for use with 2 channel switches and/or sensors.
URAX-C1R 	2TLA020072R0400	AS-i connection block for use with 2 channel switches or sensors. Local reset function available.
URAX-D1R 	2TLA020072R0500	AS-i connection block for use with sensors with OSSD signals + 3 non-safe outputs. Local reset function available. Auxiliary power required.
URAX-E1 	2TLA020072R0600	AS-i connection block for use with two-hand control stations and 3 non-safe outputs.

## Component List - AS-i Safety

Designation	Ordering Information	Description
Flex-4A	2TLA020072R5100	AS-i connection block for connection of non-safe devices. 4 non-safe inputs/outputs.
Flex-4B	2TLA020072R5000	AS-i connection block for connection of non-safe devices. 4 non-safe inputs/outputs. Auxiliary power required.

This document and any attachments may include suggested specifications, drawings, schematics and similar materials from ABB Inc. Use of such information and/or documentation by the recipient is subject to and conditioned upon your acceptance of the terms of the General Document Disclaimer which can be found at [www.jokabsafety.com](http://www.jokabsafety.com). Your acceptance of the terms of such General Document Disclaimer is conclusively presumed unless you notify ABB in writing of your disagreement with the terms of such Disclaimer immediately upon receipt of this document and you return to ABB all specifications, drawings, schematics and similar materials provided to you by ABB.

## Notes

Notes





# Vital/Tina Safety Systems

Monitor all types of safety devices!  
Eliminate the need for safety relays!  
Simplify connections and cables!



Vital Safety Dynamic Pulse Technology .....	4:2
Available in 3 Variations .....	4:3
Number of Edens that can be used with Vital and Pluto .....	4:4
Number of TinAs that can be used with Vital and Pluto .....	4:5
Why should you use the Vital Safety System? .....	4:6
How does a Vital dynamic circuit work?.....	4:7
Vital Safety Controllers.....	4:8
Vital 1 Technical Data.....	4:11
Vital 2.....	4:14
Vital 2 Technical Data.....	4:17
Vital 3.....	4:18
Vital 3 Technical Data.....	4:21
Why should you use the Tina Adapter Units? .....	4:22
Available in Several Variations .....	4:23
Tina 1A Blanking Plug for Connection Block.....	4:24
Tina 2A/B Adaptation Unit .....	4:25
Tina 3A/Aps Adaptation Unit.....	4:26
Tina 4A Connection Block .....	4:27
Tina 5A Adaptation Unit.....	4:28
Tina 6A Adaptation Unit.....	4:30
Tina 7A Adaptation Unit.....	4:31
Tina 8A Connection Block .....	4:32
Tina 10A/B/C Adaptation Unit.....	4:34
Tina 11A Terminal Block.....	4:36
Tina 12A Terminal Block.....	4:37
Accessories .....	4:38
Example of Safety Component Connections based on 'Y' Branch .....	4:39
Connection Examples .....	4:40
Component List and Ordering Information .....	4:57

# Safety System using Vital Safety Dynamic Pulse Technology

Vital is a safety controller with a dynamic safety circuit that can monitor up to 30 sensors, such as Eden, in accordance with the highest safety level. The safety loop can be expanded by using Tina Duo. Vital has selectable manual or automatic resetting and dual outputs. (The Pluto Safety PLC has many inputs for dynamic safety circuits.)

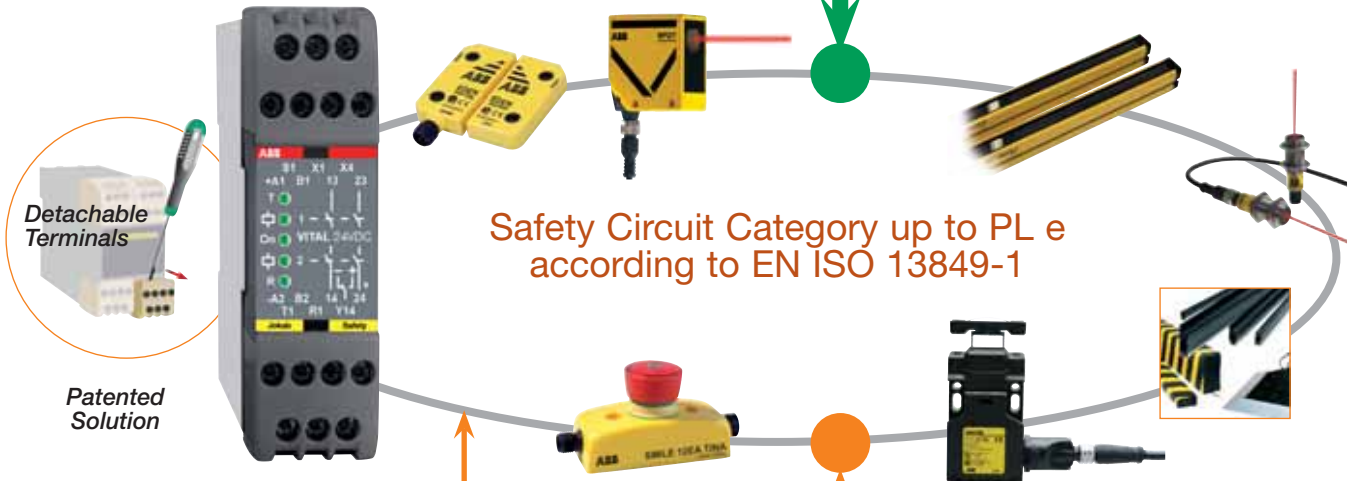

## Dynamic Safety

Dynamic "twinned" safety signal that tests a sensor, for example, 200 times per second.

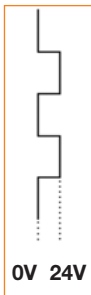

## LED Indication

Each active sensor and Tina unit has LEDs that indicate OK (green), broken safety circuit (red) or flashing if the loop has been broken by another, earlier, sensor.

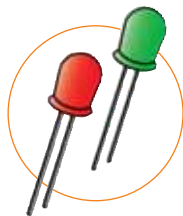



Dynamic Circuit 1

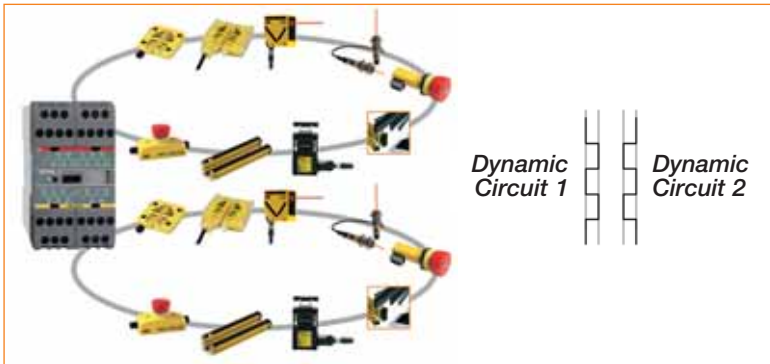

Dynamic Circuit 1      Dynamic Circuit 2

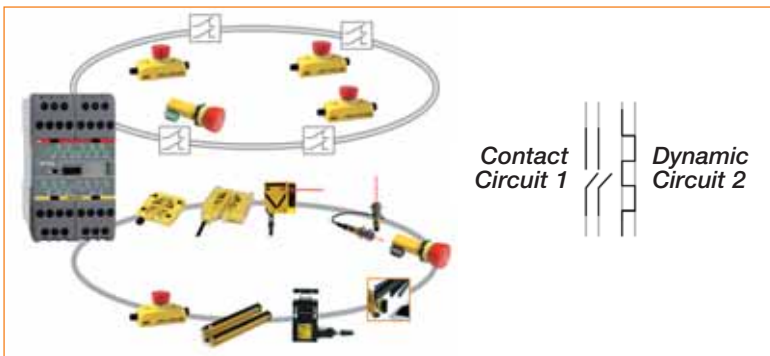

Contact Circuit 1      Dynamic Circuit 2

## Available in 3 Variations

### Vital 1

- Up to 30 sensors can be connected to the same dynamic safety circuit

### Vital 2

- Two safety circuits are monitored by one module
- Simple system with extensive functionality
- Up to 10 sensors can be connected to each dynamic safety circuit
- Output group 2 can be set for time delay
- Three different modes of operation

### Vital 3

- Two safety circuits are monitored by one module
- Devices with two-channel, opening contacts can be connected to one circuit
- Simple system with extensive functionality
- Output group 2 can be set for time delay
- Three different modes of operation

## One Vital Supervises the Entire Robot Cell!

### Two Charging Stations

At each charging station a light curtain checks for anyone putting their hand into a risk area, and an Eden sensor checks whether a robot is inside the same risk area. This means that a stop is only ordered if a robot and a person are in the same area. When the station is clear, the person presses the reset button connected to the light curtain.

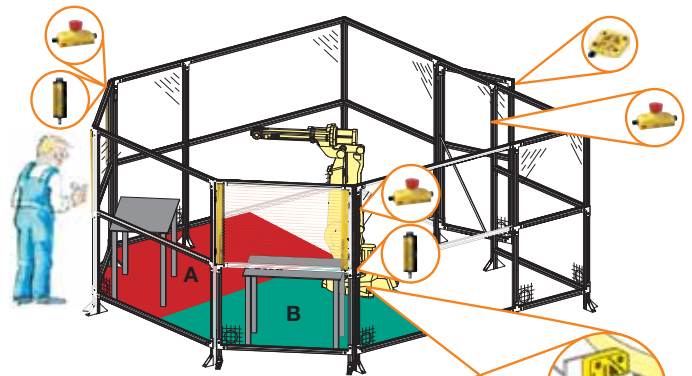

### Fence with Eden Interlocked Door

If the door is opened, the robot stops. To reset the robot system, the door must be closed and a supervisory reset button operated.

### Three Emergency Stops with Tina Units

If any of the emergency stop buttons is pressed, the robot performs an immediate stop.

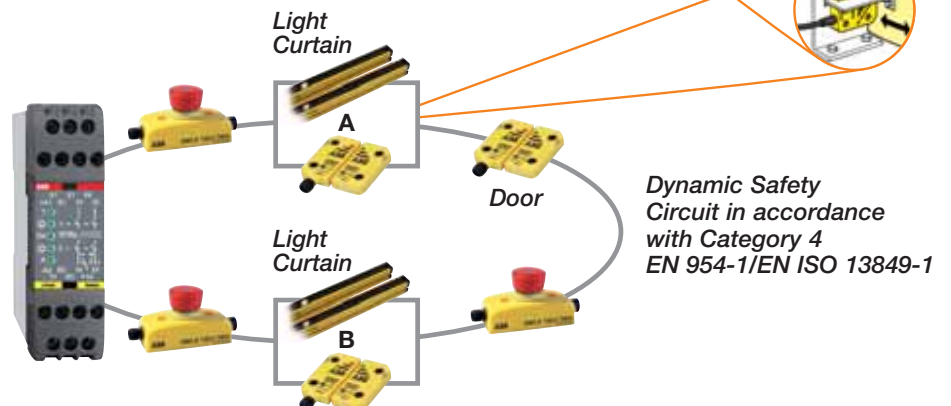

Dynamic Safety Circuit in accordance with Category 4 EN 954-1/EN ISO 13849-1

## Number of Edens That Can Be Used with Vital and Pluto

The tables below show the number of Edens that can be connected to Vital and Pluto with the maximum voltage variation. The values have been established in a laboratory environment. The actual possible number of connected Edens may therefore differ from those given in the table. The values should be regarded as guidelines; ABB Jokab Safety recommends a

maximum of 30 Edens per Vital 1 and a maximum of 10 Edens per Pluto and Vital 2/3 input. The table was prepared according to measurements with connection example A. If connection example B and 0.34 mm<sup>2</sup> cable is used (with feed voltage from two directions), the values for 0.75 mm<sup>2</sup> in the tables are used.

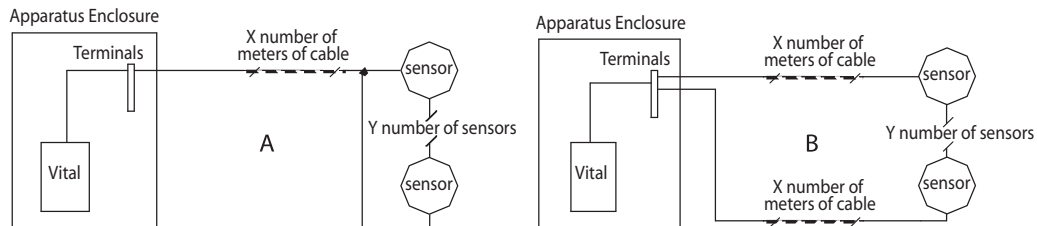

### Number of Edens That Can Be Used with Vital 1

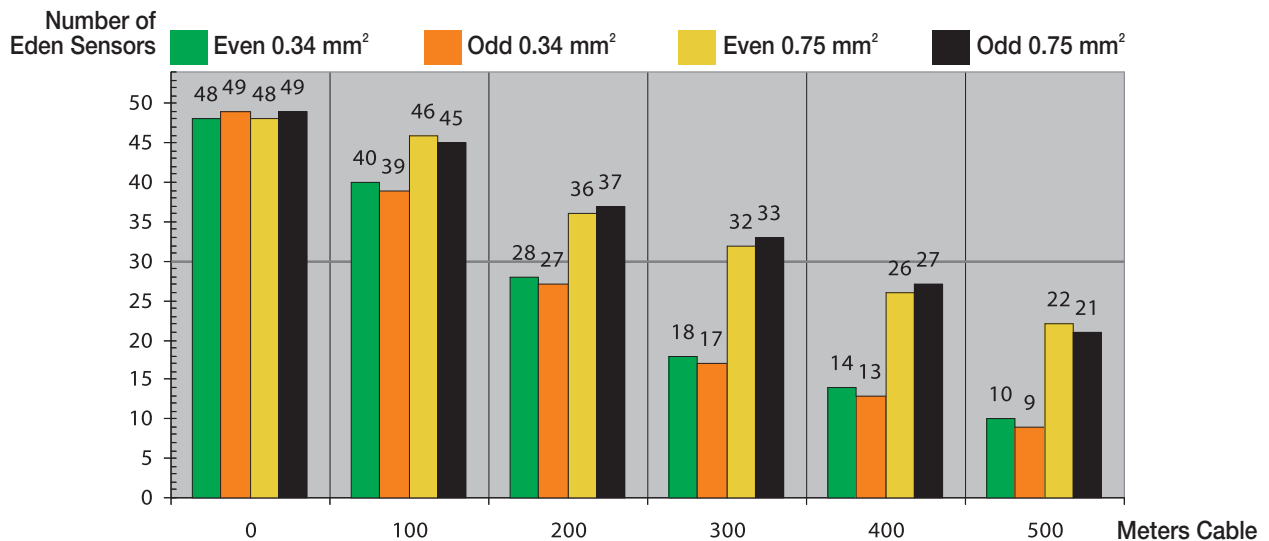

### Number of Edens That Can Be Used with Pluto and Vital 2/3

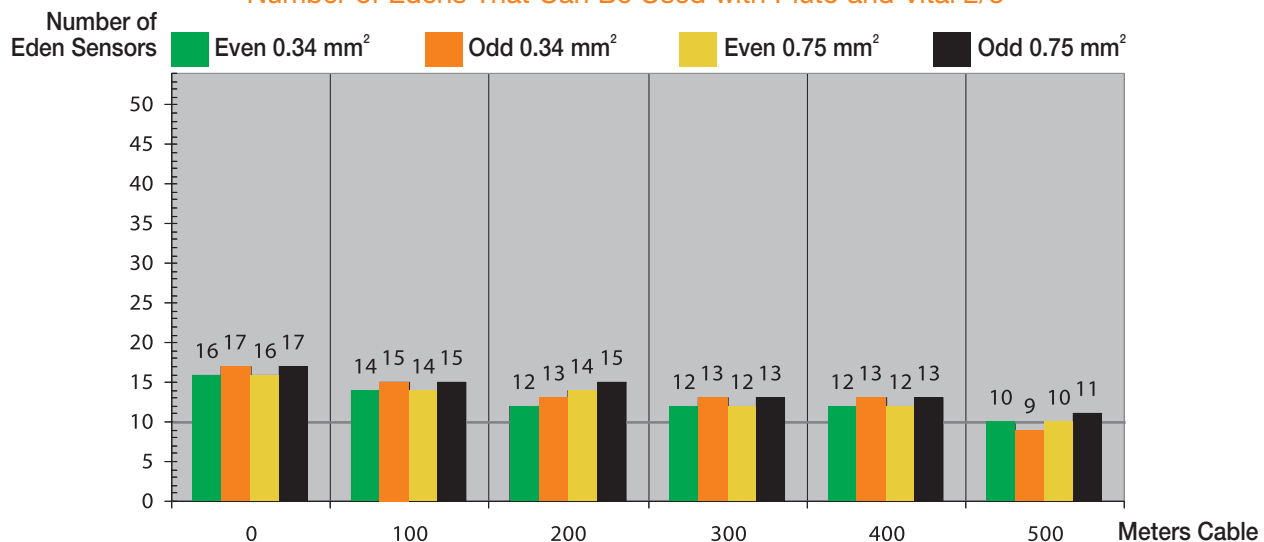

## Number of Tinas That Can Be Used with Vital and Pluto

The following tables show the numbers of Tina-3A, Tina-6A, Tina-7A and SmileTina that can be connected to Vital and Pluto with the max voltage variation. The values have been established in a laboratory environment. The actual possible number of connected units may therefore differ from those given in the table. The values should be regarded as guidelines;

ABB Jokab Safety recommends a maximum of 30 units per Vital 1 and a maximum of 10 units per Pluto and Vital 2/3 input. The table was prepared according to measurements with connection example A. If connection example B and 0.34 mm<sup>2</sup> cable is used, the values for 0.75 mm<sup>2</sup> in the tables are used.

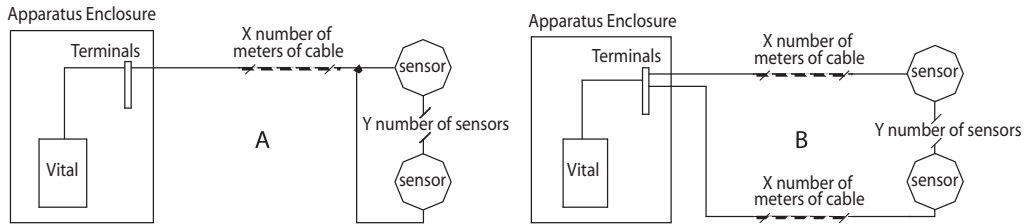

### Number of Tina-3A, 6A, 7A and Smile Tinas That Can Be Used with Vital 1

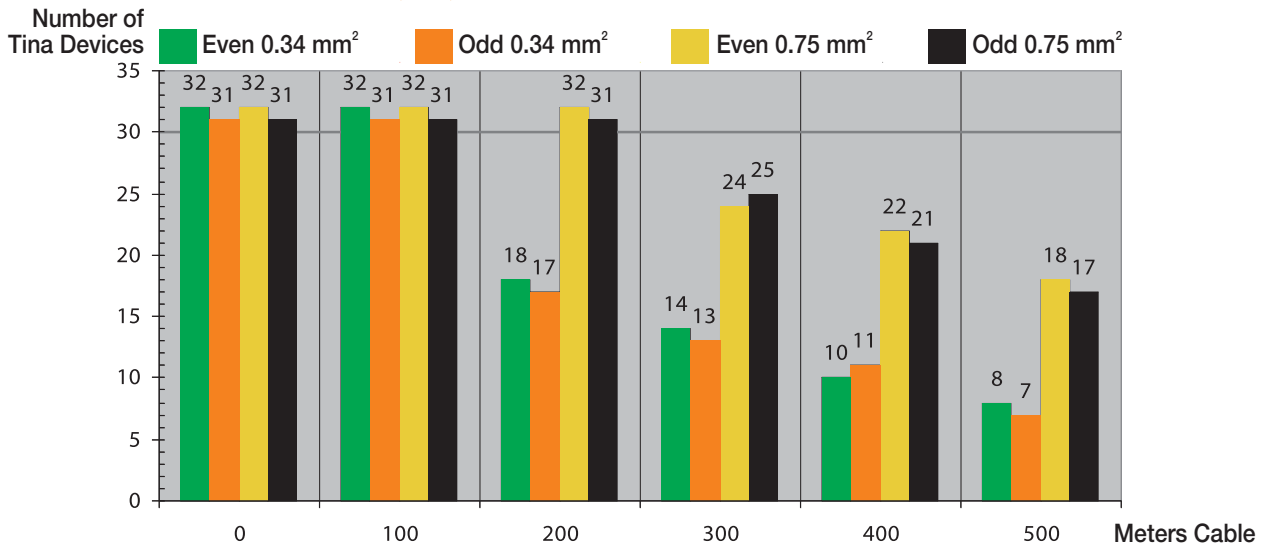

### Number of Tina-3A, 6A, 7A and Smile Tinas That Can Be Used with Pluto and Vital 2/3

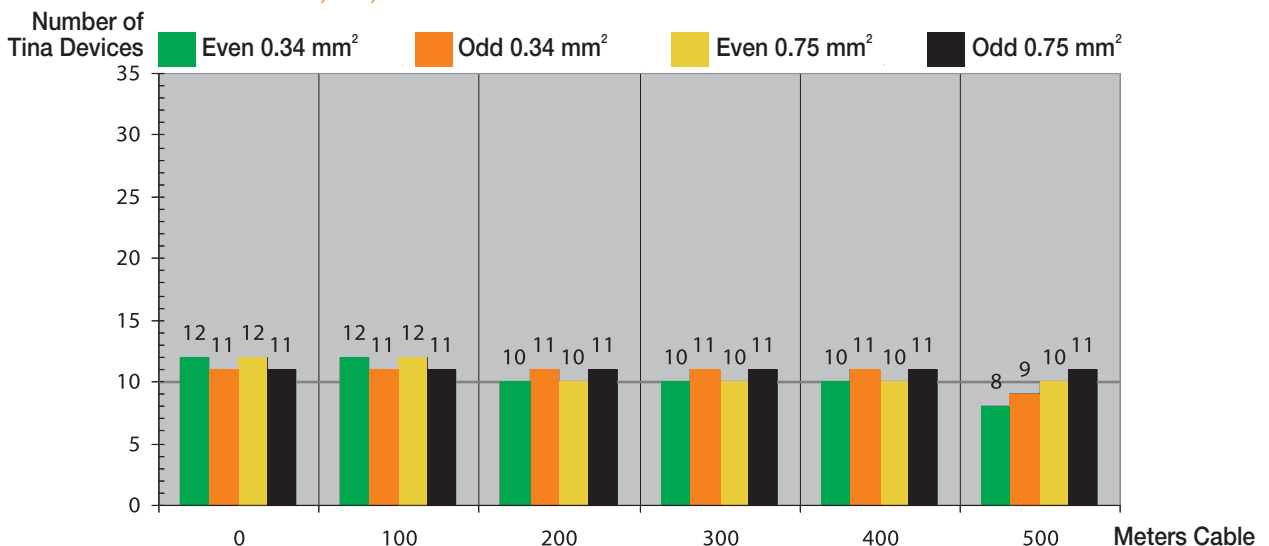

# Why should you use the Vital Safety System?

...to be able to connect several safety components in series — at Category 4 — and supervise them with only one safety controller!

Vital is the heart of a solution which makes it possible to install/connect many different types of safety devices in the same safety circuit and still achieve PL e according to EN ISO 13849-1.

The Vital module is based upon a dynamic single-channel concept as opposed to conventional dual-channel safety relays. Up to 30 dynamic sensors can be connected directly in the safety circuit and be supervised by only one Vital module. The Vital therefore replaces several safety relays. Safety components with output contacts can be connected to the Vital via low cost Tina adapters.

The Vital also has automatically or manually supervised reset selection, dual safety outputs, and an information output for reset indication and status information for PLCs.

...to supervise safety components!

Most safety components on the market can be connected to the Vital module. Dynamic sensors enable safety PL e to be achieved in a single-channel system. For example, ABB Jokab Safety's dynamic non-contact Eden sensor, Spot light beam and emergency stops (via Tina adapters) can be used. Even mechanical switches can be connected to Vital with the aid of ABB Jokab Safety's Tina adapters.

...for easy installation and assembly of a safety system!

Vital is a small electronic safety controller that dynamically supervises a number of safety components. Vital's detachable connector blocks simplify the connection, troubleshooting and exchange of modules. The Vital and other safety components can be connected together using standard cables and with cables having M12 connections.



## Why should you choose Vital?

- PL e, according to EN ISO 13849-1 dynamic safety circuit
- Can accommodate long cable lengths
- Manually supervised or automatic reset
- Two NO safety outputs
- Detachable connector blocks
- LED indication of power supply, dynamic signal and outputs
- Information output with two functions
- Cost-effective cable routing/connections

# How does a Vital dynamic circuit work?

The dynamic signal consists of a square wave that is transmitted through the safety circuit. The signal is inverted at each safety component and is monitored 200 times per second by Vital or Pluto.

The dynamic signal is transmitted as single channel throughout all the protection in the same safety circuit between input terminals T1 and R1. If a protection breaks, the dynamic signal is not transmitted — which is detected by Vital — which breaks its safe outputs. Even short circuits across a protection are detected since the signal is inverted in each sensor (the protection is then OK), while Vital expects a correctly inverted signal at the right time.

In this case, an even number of sensors are connected to the safety loop which means that the dynamic signal will be inverted an even number of times when it is evaluated by Vital. This is determined by the terminal inputs S1 and B1 being connected together. If an odd number of sensors have been connected, connection of S1 is not required. As the signal is evaluated by Vital at each pulse, i.e. more than 200 times per second, faults and short circuits are detected within a few milliseconds.

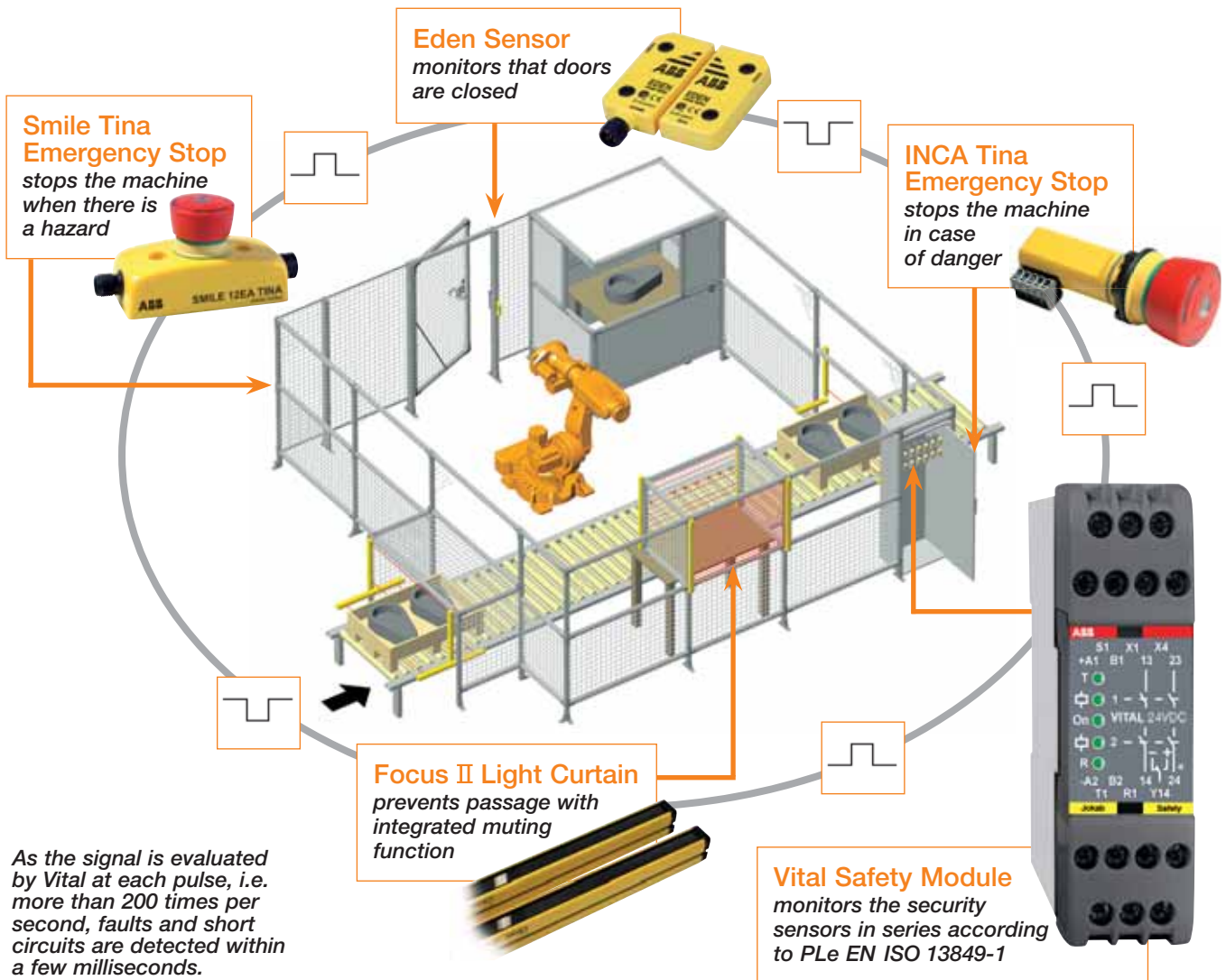

# Vital Safety Controllers

Vital is based on a single channel safety concept where multiple safety sensors can be connected in series and monitored with a single safety controller. A dynamic signal is sent from Vital through all connected sensors, and then returned to Vital which then evaluates the received signal. As each safety sensor inverts the signal, it is possible to detect short circuits or faults in any of the sensors.

Vital 2 and Vital 3 are designed for use with ABB Jokab Safety Eden sensors, Tina components and Spot light grids or similar products. Vital 2 and Vital 3 are both safety controllers with two safe input functions and two output groups. The only difference between the two models being in the input configuration.



## Applications

- Entire safety system based on the dynamic safety system

## Features

- Easy installation
- Flexible
- Cost effective
- Display for troubleshooting (Vital 2 and Vital 3)
- A wide range of safety sensors can be connected into the circuit
- Several safe outputs
- Information output
- Outputs with time delay (Vital 2 and Vital 3)

## Approvals



**TÜV Nord** (Vital 1)

**TÜV Rheinland** (Vital 2 and Vital 3)



## Vital 1 Safety Controller

- Up to 30 sensors can be connected to the same dynamic safety circuit



## Vital 2 Safety Controller

- Two safety circuits are monitored by one module
- Simple system with extensive functionality
- Up to 10 sensors can be connected to each dynamic safety circuit
- Output group 2 can be set for time delay
- Three different modes of operation

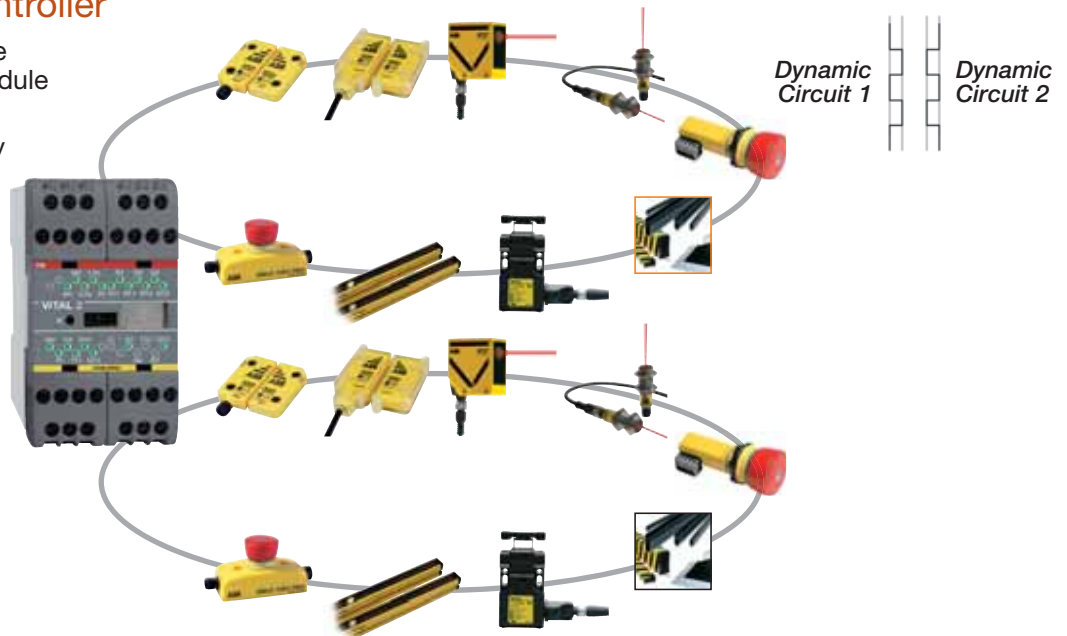

## Vital 3 Safety Controller

- Two safety circuits are monitored by one module
- Devices with two-channel, opening contacts can be connected to one circuit
- Simple system with extensive functionality
- Output group 2 can be set for time delay
- Three different modes of operation

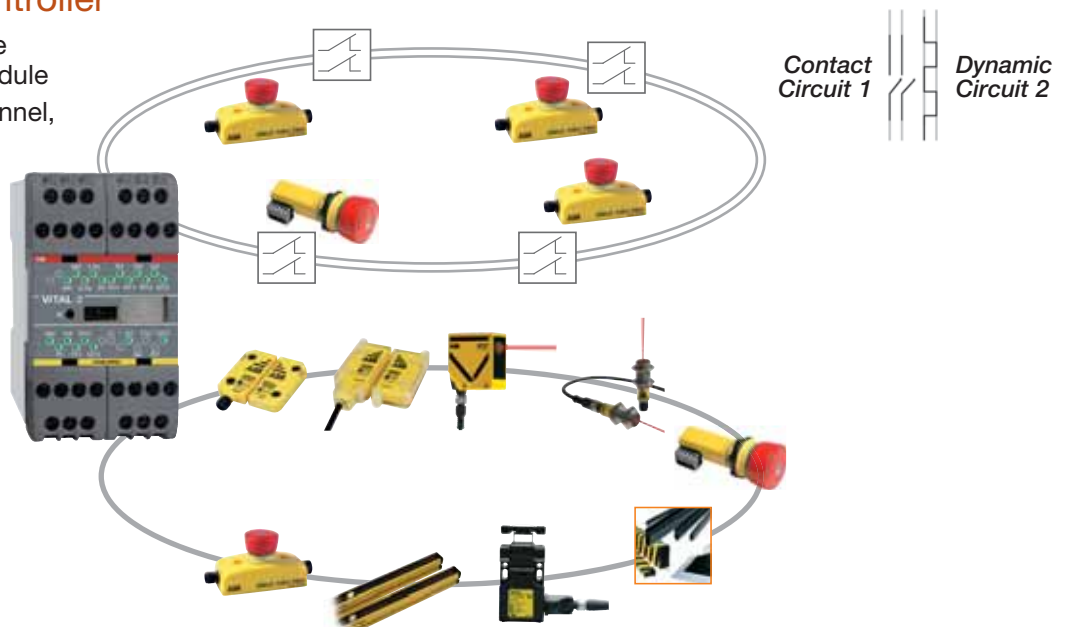

# Vital 1 Reset Connections

## Manual Supervised Reset

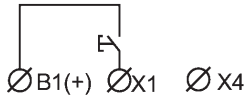

The manual supervised reset contact connected to input X1 must be closed and opened in order to activate the relay output.

## Automatic Reset

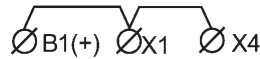

Automatic reset is selected when B1, X1 and X4 are connected. The relay outputs are then activated at the same time as the inputs.

## Testing External Contactor Status

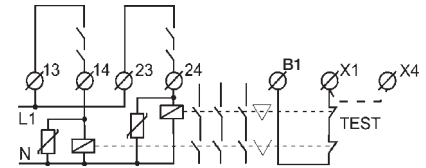

Contactors, relays and valves can be supervised by connecting 'test' contacts between B1 and X1. Both manually supervised and automatic reset can be used.

# Vital 1 Output Connections

## Relay Outputs

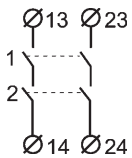

The Vital 1 has two (2 NO) safety outputs. In order to protect the output contacts it is recommended that loads (inductive) are suppressed by fitting correctly chosen VDRs, diodes etc. Diodes are the best arc suppressors, but will increase the switch off time of the load.

## Connection of S1

Even number of units in series (Eden+ Spot+Tina) requires a connection between B1 and S1. S1 is not connected at odd number of units.

See drawing below figure A and other examples in the book.

## Information Outputs

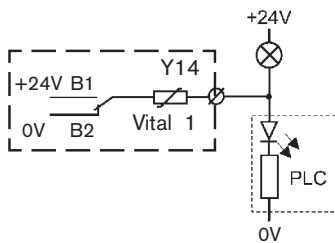

Vital 1 has a switching relay output for information. The function is determined by a DIP switch.

The DIP switch position 1 (original position) is the information output Y14 internally connected to 0V and +24 V as per:

- Y14 is closed to 0V (B2) internally when Vital 1 has not been reset.
- Y14 is closed to +24 V (B1) when Vital 1 has been reset.

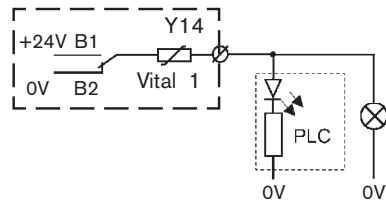

In DIP switch position 2 (the purpose of the function is to start/restart block, RES) the information output Y14 is internally connected to 0V and +24 V as per:

- Y14 is internally closed to 0V (B2) when the dynamic safety loop is open or when the dynamic safety loop is closed and Vital 1 has been reset.
- Y14 is internally closed to +24 V (B1) when the dynamic safety loop is closed but Vital 1 has not been reset (RES).

# Vital 1 Connection of Safety Devices

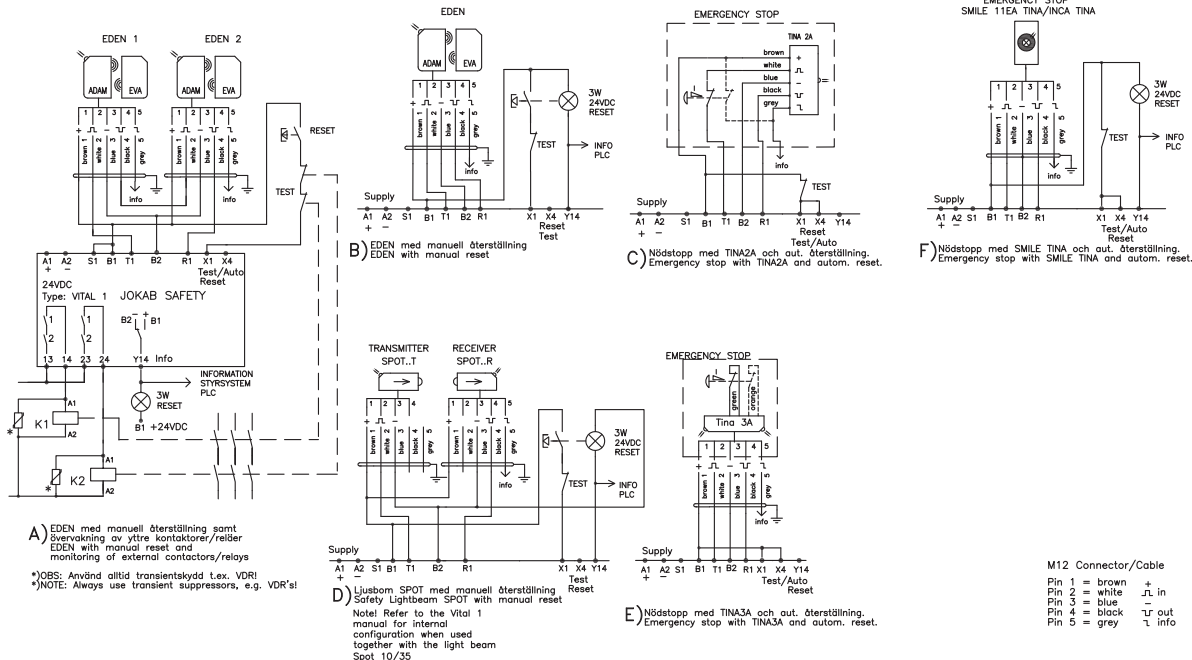

## Vital 1 Technical Data

<b>Manufacturer</b>	ABB AB/Jokab Safety, Sweden
<b>Ordering information</b>	see page 4:57
<b>Level of safety</b> EN ISO 13849-1 EN 62061 IEC/EN 61508-1...7 EN 954-1	PL e, category 4 SIL 3 SIL 3 Category 4
<b>PFH<sub>d</sub></b>	2.74×10 <sup>-8</sup>
<b>Color</b>	Grey
<b>Weight</b>	220 g
<b>Power supply</b> Vital, A1-A2 From Vital to sensors/units, B1-B2	24 VDC ±15% 24 VDC
<b>Fuse</b> An external fuse should be fitted in the supply to A1	3 AT
<b>Max line resistance</b> at nominal voltage to X1	150 Ohm
<b>Power consumption</b> DC supply, nominal voltage (without load) DC supply, nominal voltage (with max load)	3 W 48 W
<b>Dynamic safety circuit</b> T 1 R 1	Output signal Input signal
<b>Reset input X1</b> Supply for reset input Reset current	+24VDC 30 mA max. (inrush current 300 mA during contact closure)
Minimum contact closure time for reset	80 ms
<b>Connection of S1</b> Even numbers of sensors (Eden + Spot T/R + Tina) require a connection between B1 and S1. S1 is not connected for odd numbers of sensors. Odd number, no connection between B1 and S1	
<b>Number of sensors</b> Max. number of Eden/Tina to Vital 1 Total max. cable length to Eden/Tina Max. number of Spot T/R to Vital Total max. cable length to Spot T/R	30 1000 m 6 pairs 600 m
Maximum number of units varies depending on the installation and cable size. For more information, see the examples in this chapter	
<b>Response time</b> At Power on When activating (input-output) When deactivating (input-output) At Power loss	< 65 ms < 40 ms < 38 ms < 45 ms
<b>Relay outputs</b> NO Max switching capacity, resistive load Minimum load Contact material Mechanical life External fuse (EN 60947-5-1)	2 6A/250 VAC/1500 VA/150W 10 mA/10V AgCdO >10 <sup>7</sup> operations 6.3A or 4A slow

<b>Relay information output</b> (changeover contact) Y14 - (0V) + (24V) Max. load on Y14	Indicates Vital is not reset Indicates Vital is reset 200 mA (Internal automatic fuse)
<b>LED indication</b>  On ●  T ● R ● ☐ ● 1 ☐ ● 2	Fixed light: supply voltage OK, Flashing light: under-voltage or overload T: Signal out OK. R: Signal in OK. Indicates that the output relays have been activated
<b>Mounting</b> DIN rail Operating temperature range	35 mm DIN rail -10°C to + 55°C
<b>Connection blocks (detachable)</b> Max screw torque Max connection area: Solid conductors Conductor with socket contact Air and creep distance	1 Nm 1x4 mm <sup>2</sup> /2x1.5 mm <sup>2</sup> /12AWG 1x2.5 mm <sup>2</sup> /2x1 mm <sup>2</sup> 4kV/2 DIN VDE 0110
<b>Protection class</b> Enclosure Connection blocks	IP 40 IEC 60529 IP 20 IEC 60529
<b>Conformity</b>	EN ISO 12100-1, EN ISO 12100-2, EN 954-1, EN ISO 13849-1, EN 62061, EN 60204-1, IEC 60664-1, EN 61000-6-2, EN 61000-6-4 EN 60947-5-1, EN 1088, EN 61496-1, IEC/EN 61508-1...7

**Note:**  
Connector  
blocks are  
detachable  
without cables  
having to be  
disconnected.

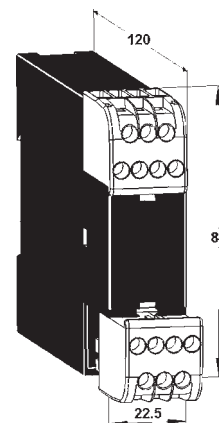

# Connection of Units and Cable Lengths to Vital 1

CONNECTION EXAMPLE VITAL1 SOLUTIONS

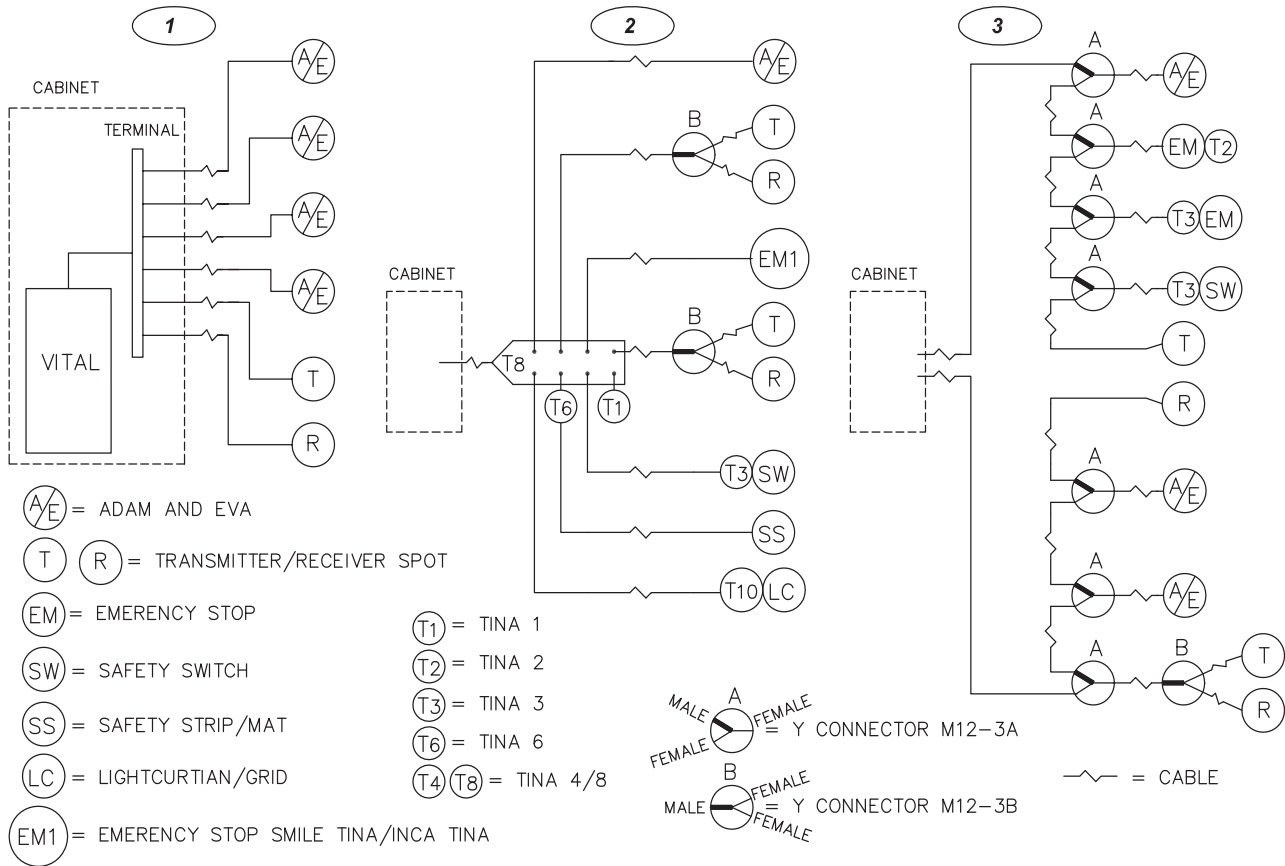

INFORMATION IS AVAILABLE VIA CABLE FROM EACH SENSOR IN EX. **1** AND **2**

HH3400A2

SEE DISCLAIMER ON PAGE 4:64

### Three Connection Alternatives

According to PL e (EN ISO 13849-1), connection of sensors/adaptor units in the Vital safety circuit **must be made per the connection examples.**

#### Example 1

Use separate connection cables from each sensor/adaptor unit to the Vital safety controller. Interconnections to be made via suitable terminals in the control cabinet.

#### Example 2

Use Tina4A/Tina8A connector blocks to simplify the connection of externally mounted sensors/adaptor units. Only Tina4A/Tina8A connector blocks may be used. **Use of any other connector blocks will not meet the safety circuit requirements.**

#### Example 3

Use M12-3A and M12-3B “Y” connectors to connect sensors in series/parallel.

### Cable Lengths and Number of Sensor/Adapter Units for the Three Connection Examples

In order to determine the number of sensor/adaptor units that can be connected to a Vital 1 unit it must be remembered that 1 (one) Spot T/R is equivalent to 5 (five) Eden or Tina units. Units in parallel are equal to one unit. The following examples provide guidance as to possible configurations and cable lengths using suitable cables.

#### Example 1

Up to 1000 meters (0.75 mm<sup>2</sup> or 0.34 mm<sup>2</sup> conductors) in total can be connected to the sensors/units in this example. The connection is equivalent to 9 Eden or Tina units.

A maximum of 30 Eden or Tina units can be connected to the Vital 1 unit on a maximum cable length of 500 meters (0.75 mm<sup>2</sup> conductors) or 300 meters (0.34 mm<sup>2</sup> conductors).

#### Example 2

Up to 600 meters (0.75 mm<sup>2</sup> conductors) to Tina 8A and 10 meter cables type M12-C1012 (0.34 mm<sup>2</sup>) to each sensor/unit connected to the Tina 8A. This connection example is equivalent to 17 Eden or Tina units.

A maximum of 3 Tina 8A units, equivalent to 27 Eden/Tina units (= 3 x 8 connected to Tina 8A + 3 Tina 8A) can be connected to one Vital 1 with a total cable length of 600 meters (0.75 mm<sup>2</sup>). Up to 6 Tina 4A units can be connected to one Vital 1 (equivalent to 30 Eden/Tina units) with a total cable length of 600 meters (0.75 mm<sup>2</sup>) to Tina 4A.

#### Example 3

Either 2 x 500 meter cables (0.75 mm<sup>2</sup>) from the control cabinet and 10 meter cables (0.34 mm<sup>2</sup>) to each sensor/unit or 2 x 10 meter cables (0.75 mm<sup>2</sup>) from the control cabinet and 200 meter cables (0.75 mm<sup>2</sup>) to each sensor/unit. The connection is equivalent to 16 Eden or Tina units.

A Total of 30 Eden/Tina units can be connected using a maximum cable length of 1000 meters (0.75 mm<sup>2</sup>) or 400 meters (0.34 mm<sup>2</sup>). If the power supply is only fed from one direction (from one end of the network) the total cable length is reduced to approx 300 meters (0.75 mm<sup>2</sup>) and 100 meters (0.34 mm<sup>2</sup>).

### Connection Advice for Dynamic Sensors to Pluto and Vital

Sensors can be connected in many different ways. Here is some advice that can make connection better and more stable. The advice is general, but particularly applicable to the use of Tina 4A and Tina 8A units.

- Never have more than the recommended number of sensors in the loop.
- If possible use a switched main power supply that can deliver a stable 24 VDC.
- In the sensor system, use as short cables as possible.
- When connecting a Tina 4A or Tina 8A unit, the supply voltage at the terminal (out at the unit) must not be less than 20 Volts.
- Use screened cable, preferably 0.75 mm<sup>2</sup> or thicker, from the apparatus enclosure and ground it at one end, for example at the apparatus enclosure, not at both ends.
- Do not route the signal wiring close to heavy current cabling or close to equipment that gives off a lot of interference, such as frequency converters for electric motors.
- Never connect “spare” conductors.
- If M12-3B are used for connection of a parallel loop, with supply to the sensors from two directions, the loop must be as short as possible. This is because the conductors that are not being used are also connected, which increases the capacitive load and reduces the stability of the system.

# Vital 2

Vital 2 is a safety controller that combines functionality with the quick and easy installation of safety sensors. With two safe input functions and two different output groups, Vital 2 offers the capability to exclusively control smaller machine safety systems that would otherwise have required a programmable controller or multiple safety relays.

How the two output groups are controlled by the input functions depends on which of the three operating modes is selected (see Selection of operating mode).

## Input Function 1

A dynamic safety circuit where ABB Jokab Safety's safety sensors such as Eden, Tina and Spot can easily be connected in series. Up to 10 Eden or Tina devices can be connected in series per input function.

## Input Function 2

The same function as input function 1.

*Output group 1:* A safe relay output in a duplicated series and a safe transistor output with output voltage of -24 VDC.

*Output group 2:* A safe relay output in a duplicated series and a safe transistor output with output voltage of -24 VDC. In addition, output group 2 contains a non-safe transistor output with output voltage of +24 VDC, intended for information. The output group can have time delay from 0 to 1.5 s.

## Selection of Operating Modes

Vital 2 can be configured to operate in one of three operating modes M1, M2 or M3. The selection of operating modes is done by connecting one of the terminals M1, M2 or M3 to +24 V.

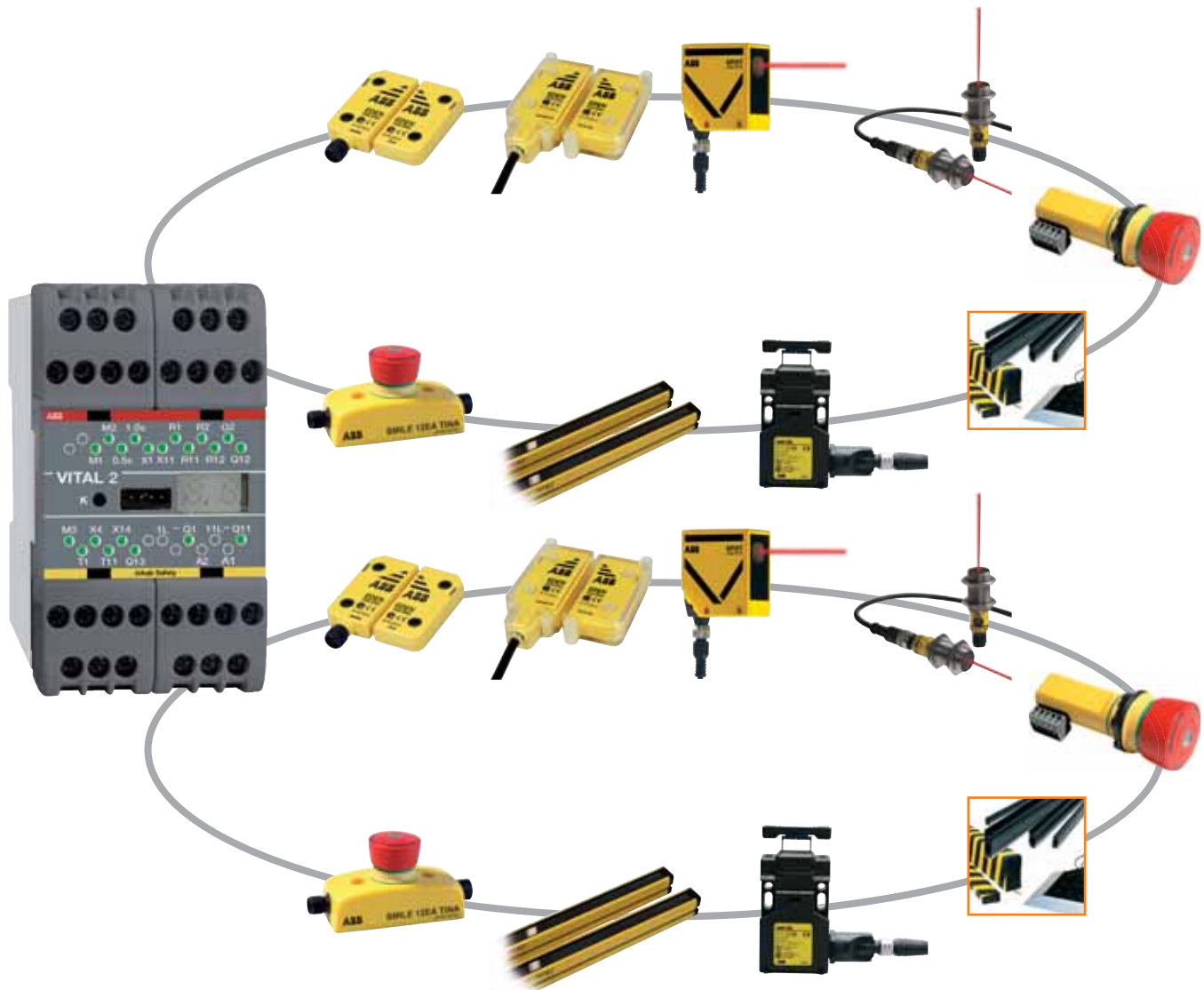

## Operating Mode M1 - Separate Function Vital 1

Input function 1 controls output group 1, and input function 2 controls output group 2.

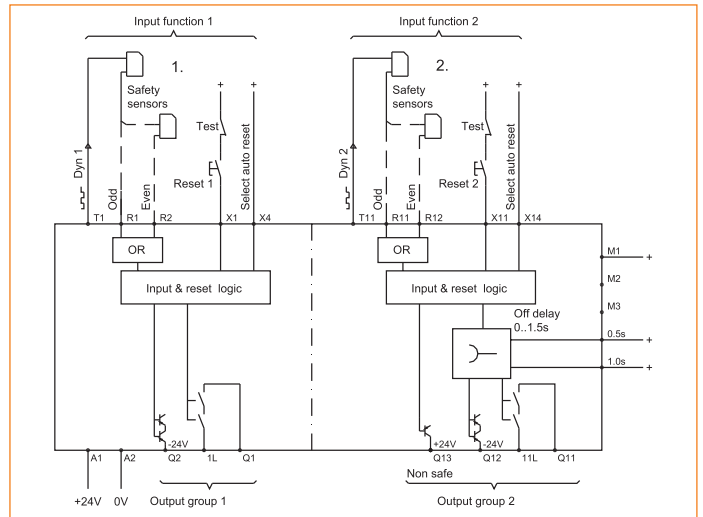

## Operating Mode M2 - Input 1, Master Function Vital 2

Input function 1 stops all outputs, and input function 2 stops output group 2.

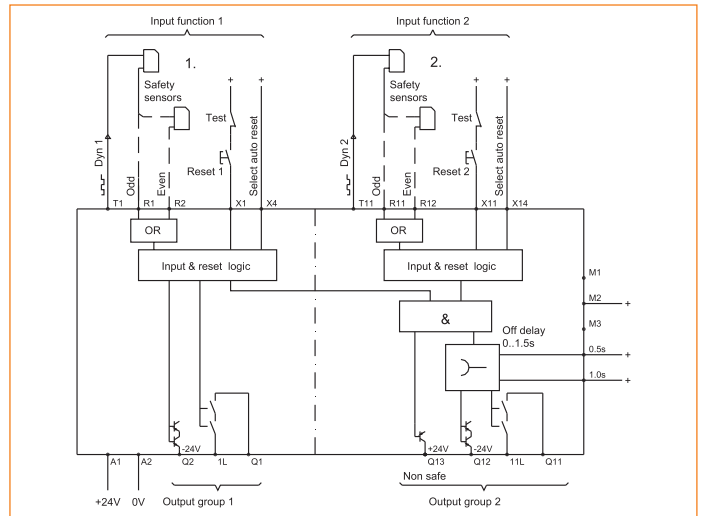

## Operating Mode M3 - Parallel Function Vital 2

Input function 1 and input function 2 operate in parallel and control all outputs. Reset/Auto reset 1 resets both input functions (Reset/Auto Reset 2 is not used).

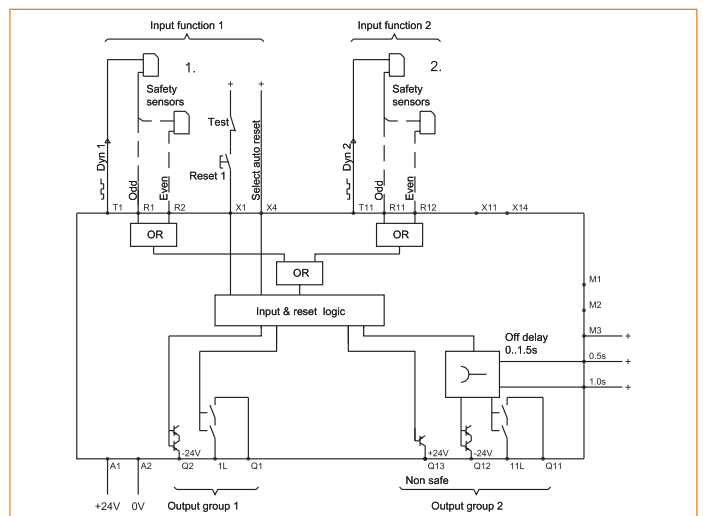

## Connection of Protection/Sensors - Vital 2

Depending on the input function and the number of sensors connected to the safety circuit (odd or even number), the dynamic signal is connected between different terminals;

### Input function 1:

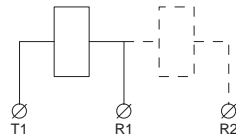

A dynamic signal is transmitted from T1, and depending on the number of sensors in the safety circuit, the signal connects back to R1 (odd number of sensors) or R2 (even number of sensors).

### Input function 2:

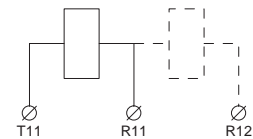

A dynamic signal is transmitted from T11, and depending on the number of sensors in the safety circuit, the signal connects back to R11 (odd number of sensors) or R12 (even number of sensors).

## Connection of Outputs - Vital 2

### Connection of safe transistor output (-24 V)

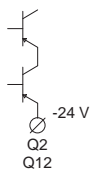

The safe transistor outputs Q2 (output group 1) and Q12 (output group 2) have an output voltage of -24 V.

### Connection of safe relay output

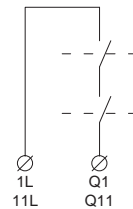

The safe relay outputs that are duplicated in series break between 1L-Q1 (output group 1) and 11L-Q11 (output group 2). The loads that break should be fitted with spark arresters to protect the outputs. The correct selection of VDR circuit, RC circuit or diode is appropriate. Note that the diode extends the disconnection time of the load.

### Connection of information output

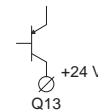

The non-safe transistor output Q13 is high (+24 V) when the outputs from output group 2 are active. The function is therefore dependent on the operating mode selected (see Selection of operating mode).

## Connection of Reset - Vital 2

There are two separate reset functions; Reset 1 and Reset 2. The function of these is dependent on the operating mode selected (see Selection of operating mode). Reset 1 and Reset 2 can be configured for manual or automatic reset independently of each other by means of the input's Auto reset 1 and Auto reset 2.

### Manual monitored reset

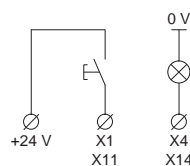

For manual resetting, a push button must be connected between X1 (Reset 1) or X11 (Reset 2) and +24 V. The monitoring contactors for external devices are to be connected in series with the push button. For manual reset, X4 (for Reset 1) and X14 (for Reset 2) serve as output for resetting the indicator lamps.

### Automatic reset

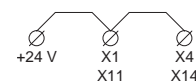

For automatic reset, X1 and X4 (Auto reset 1) or X11 and X14 (Auto reset 2) must be connected to +24 V. Monitoring contactors for external devices must be connected between +24 V and X1 (Auto reset 1) or X11 (Auto reset 2). If monitoring contactors are not used, X1 and X11 must be connected to +24 V.

## Time Delay - Vital 2

Output group 2 can have disconnection delay by connecting inputs 0.5s and 1.0s being connected to +24 V. The system is binary, which means that the time values of the inputs are added together to give the total delay time.



No delay

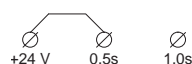

0.5 s delay



1.0 s delay



1.5 s delay



## Vital 2 Technical Data

<b>Manufacturer</b>	ABB AB/Jokab Safety, Sweden	<b>Relay outputs</b>	2 NO 6A/250 VAC Max. load capacity, res. load Max. load capacity, ind. load	2 NO 6A/250 VAC AC-1: 250 V/1.5 A AC-15: 250 V/1.5 A DC-1: 50 V/1.5 A DC-14: 24 V/1.5 A
<b>Ordering information</b>	see page 4:57	<b>Safe transistor outputs</b>	Number of outputs Output voltage (rated) Output voltage (at load)	2 -24V > 22V at 800 mA/24V supply voltage 23,3V at 150 mA/24V supply voltage 800 mA
<b>Level of safety</b> EN ISO 13849-1 EN 62061 IEC/EN 61508-1...7 EN 954-1	PL e, category 4 SIL 3 SIL 3 Category 4	<b>Fuse</b>	Short circuit protection Output - 0V Output - +24V	Yes Normal (not guaranteed)
<b>PFH<sub>d</sub></b> Relay output Transistor output	2.00×10 <sup>-9</sup> 1.50×10 <sup>-9</sup>	<b>Non-safe transistor output (information)</b>	Output voltage (rated) Max. load	+24 VDC 1 A
<b>Color</b>	Grey	<b>Mounting</b>	DIN rail	35 mm DIN rail
<b>Weight</b>	390 g	<b>Operating temperature range</b>		-10°C to + 55°C
<b>Power supply</b>	24 VDC ±15%	<b>Connection blocks (detachable)</b>	Max screw torque Max connection area: Solid conductors Conductor with socket contact Air and creep distance	1 Nm 1x4 mm <sup>2</sup> /2x1.5 mm <sup>2</sup> /12AWG 1x2.5 mm <sup>2</sup> /2x1 mm <sup>2</sup> 4kV/2 DIN VDE 0110
<b>Fuse</b> An external fuse must be connected in series with the supply voltage to A1	6 A	<b>Protection class</b>	Enclosure Connection blocks	IP 40 IEC 60529 IP 20 IEC 60529
<b>Max line resistance</b> at nominal voltage to X1	150 Ohm	<b>Approved standards</b>		EN ISO 13849-1/EN 954-1 EN ISO 13849-2 EN 62061 EN 61496-1 EN 574 EN 692 EN 60204-1 EN 50178 EN 61000-6-2 EN 61000-6-4 EN 61000-4- IEC/EN 61508-1...7
<b>Power consumption</b> Total current consumption	300 mA	<b>Input function 1 (dynamic safety circuit)</b> Dynamic output signal Dynamic input signal		
<b>Input function 1 (dynamic safety circuit)</b> Dynamic output signal Dynamic input signal	T1 R1 (odd number of sensors in a circuit) R2 (even number of sensors in a circuit)	<b>Input function 2 (dynamic safety circuit)</b> Dynamic output signal Dynamic input signal		
<b>Input function 2 (dynamic safety circuit)</b> Dynamic output signal Dynamic input signal	T11 R11 (odd number of sensors in a circuit) R12 (even number of sensors in a circuit)	<b>Reset input X1/X11</b> Voltage at X1/X11 when reset Reset current		
<b>Reset input X1/X11</b> Voltage at X1/X11 when reset Reset current	+24VDC 30 mA (300 mA peak during contact closure)	<b>Minimum contact closure time for reset</b>		80 ms
<b>Number of sensors</b> Max. number of Eden or Tina units per input function Total max. cable length (depending on the number of Eden/Tina units) Max. number of light beams (Spot T/R) per input function Spot 10 Spot 35 Total max. cable length (depending on the number of Spot T/R)	10 500 m 1 3 100 m	<b>Response time</b> Relay output (Q1, Q11) Safe transistor outputs (Q2, Q12) Non-safe transistor output (Q2, Q12)		15 – 24 ms 11 – 20 ms 11 – 20 ms
<b>Maximum number of units varies depending on the installation and cable size. For more information, see the examples in this chapter.</b>				

**Note:**  
Connector blocks are detachable without cables having to be disconnected.

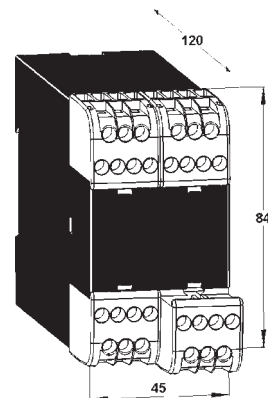

# Vital 3

Vital 3 is a safety controller that combines functionality with the quick and easy installation of safety sensors. With two safe input functions and two different output groups, Vital 3 offers the capability to exclusively control smaller machine safety systems that would otherwise have required a programmable controller or multiple safety relays.

How the two output groups are controlled by the input functions depends on which of the three operating modes is selected (see Selection of operating mode).

## Input Function 1

A two-channel safety circuit designed for opening contacts, e.g. two-channel emergency stop or ABB Jokab Safety's safety switch JSNY5. One channel is fed with the dynamic signal and the other with static +24 VDC.

## Input Function 2

A dynamic safety circuit where ABB Jokab Safety's safety sensors Eden, Tina and Spot can easily be connected in series. Up to 10 Eden or Tina devices can be connected in series per input function.

*Output group 1:* A safe relay output in a duplicated series and a safe transistor output with output voltage of -24 VDC.

*Output group 2:* A safe relay output in a duplicated series and a safe transistor output with output voltage of -24 VDC. In addition, output group 2 contains a non-safe transistor output with output voltage of +24 VDC, intended for information. The output group can have time delay from 0 to 1.5 s.

## Selection of Operating Modes

Vital 2 can be configured to operate in one of three operating modes M1, M2 or M3. The selection of operating modes is done by connecting one of the terminals M1, M2 or M3 to +24 V.

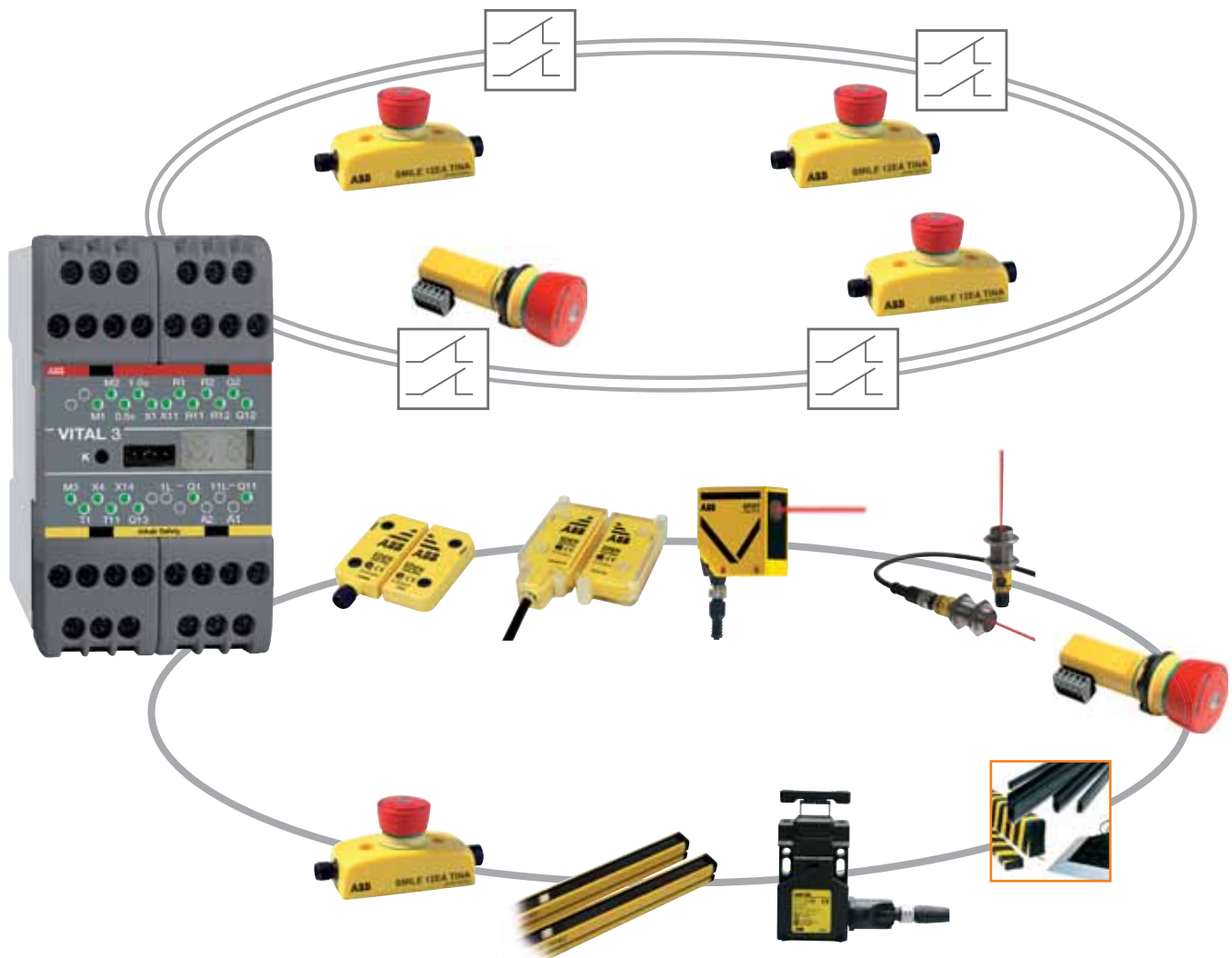

## Operating Mode M1 - Separate Function Vital 3

Input function 1 controls output group 1, and input function 2 controls output group 2.

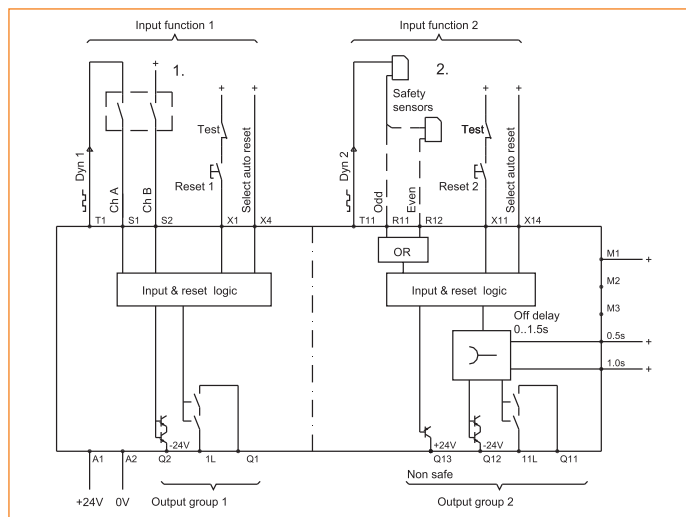

## Operating Mode M2 - Input 1, Master Function Vital 3

Input function 1 stops all outputs, and input function 2 stops output group 2.

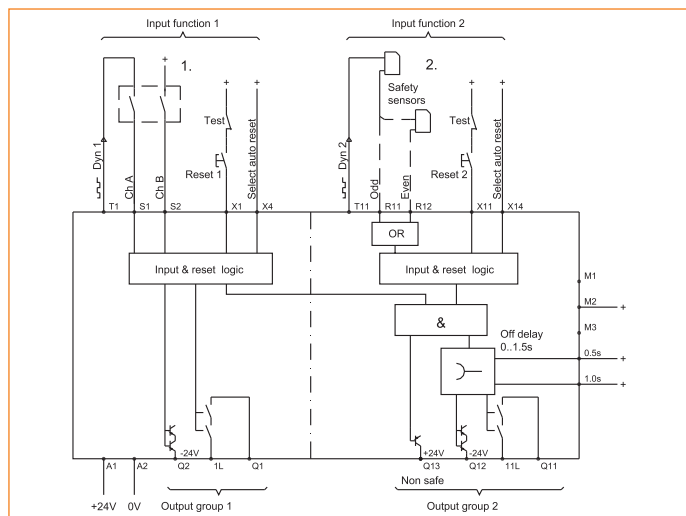

## Operating Mode M3 - Parallel Function Vital 3

Input function 1 and input function 2 operate in parallel and control all outputs. Reset/Auto reset 1 resets both input functions (Reset/Auto Reset 2 is not used).

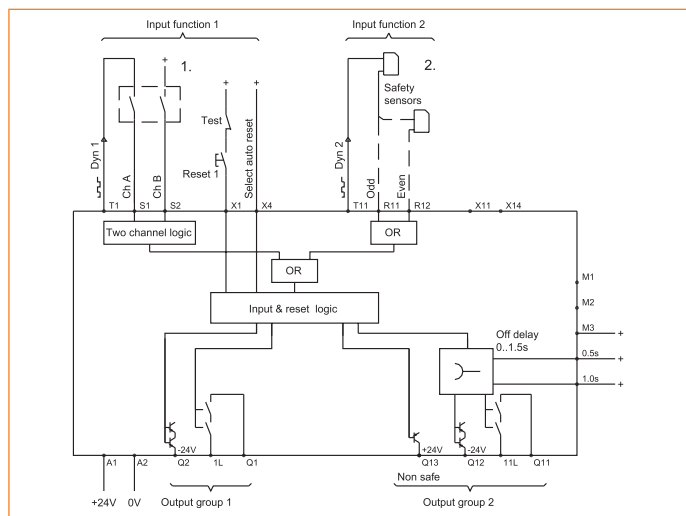

## Connection of Protection/Sensors - Vital 3

Depending on the input function and the number of sensors connected to the safety circuit (odd or even number), the dynamic signal is connected between different terminals;

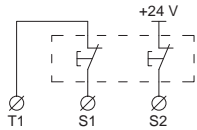

### Input function 1:

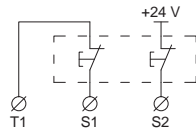

### Input function 2:

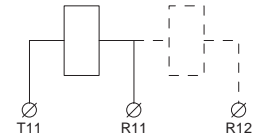

One of the two opening contacts is connected between T1 and S1 (dynamic signal). The second opening contact is connected between +24 V and S2 (static signal).

A dynamic signal is transmitted from T11, and depending on the number of sensors in the safety loop, the signal connects back to R11 (odd number of sensors) or R12 (even number of sensors).

## Connection of Outputs - Vital 3

### Connection of safe transistor output (-24 V)

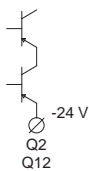

The safe transistor outputs Q2 (output group 1) and Q12 (output group 2) have an output voltage of -24 V.

### Connection of safe relay output

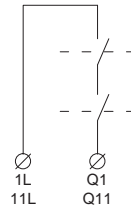

The safe relay outputs that are duplicated in series break between 1L-Q1 (output group 1) and 11L-Q11 (output group 2). The loads that break should be fitted with spark arresters to protect the outputs. The correct selection of VDR circuit, RC circuit or diode is appropriate. Note that the diode extends the disconnection time of the load.

### Connection of information output

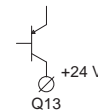

The non-safe transistor output Q13 is high (+24 V) when the outputs from output group 2 are active. The function is therefore dependent on the operating mode selected (see Selection of operating mode).

## Connection of Reset - Vital 3

There are two separate reset functions; Reset 1 and Reset 2. The function of these is dependent on the operating mode selected (see Selection of operating mode). Reset 1 and Reset 2 can be configured for manual or automatic reset independently of each other by means of the input's Auto reset 1 and Auto reset 2.

### Manual monitored reset

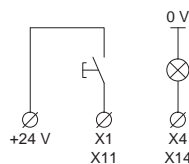

For manual resetting, a push button must be connected between X1 (Reset 1) or X11 (Reset 2) and +24 V. The monitoring contactors for external devices are to be connected in series with the push button. For manual reset, X4 (for Reset 1) and X14 (for Reset 2) serve as output for resetting the indicator lamps.

### Automatic reset

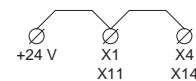

For automatic reset, X1 and X4 (Auto reset 1) or X11 and X14 (Auto reset 2) must be connected to +24 V. Monitoring contactors for external devices must be connected between +24 V and X1 (Auto reset 1) or X11 (Auto reset 2). If monitoring contactors are not used, X1 and X11 must be connected to +24 V.

## Time Delay - Vital 3

Output group 2 can have disconnection delay by connecting inputs 0.5s and 1.0s being connected to +24 V. The system is binary, which means that the time values of the inputs are added together to give the total delay time.



No delay

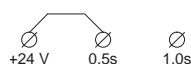

0.5 s delay



1.0 s delay



1.5 s delay

## Vital 3 Technical Data

<b>Manufacturer</b>	ABB AB/Jokab Safety, Sweden	<b>Relay outputs</b>	2 NO 6A/250 VAC AC-1: 250 V/1,5 A AC-15: 250 V/1.5 A DC-1: 50 V/1.5 A DC-14: 24 V/1.5 A
<b>Ordering information</b>	see page 4:57	<b>Safe transistor outputs</b>	2 -24V > 22V at 800 mA/24V supply voltage 23.3V at 150 mA/24V supply voltage 800 mA
<b>Level of safety</b> EN ISO 13849-1 EN 62061 IEC/EN 61508-1...7 EN 954-1	PL e, category 4 SIL 3 SIL 3 Category 4	<b>Max. load</b> <b>Short circuit protection</b>	Yes Normal (not guaranteed)
<b>PFH<sub>d</sub></b> Relay output Transistor output	2.00×10 <sup>-9</sup> 1.50×10 <sup>-9</sup>	<b>Non-safe transistor output (information)</b>	Output voltage (rated) +24 VDC Max. load 1 A
<b>Color</b>	Grey	<b>Mounting</b>	DIN rail 35 mm DIN rail
<b>Weight</b>	390 g	<b>Operating temperature range</b>	-10°C to + 55°C
<b>Power supply</b>	24 VDC ±15%	<b>Connection blocks (detachable)</b>	Max screw torque 1 Nm Max connection area: Solid conductors 1x4 mm <sup>2</sup> /2x1.5 mm <sup>2</sup> /12AWG Conductor with socket contact 1x2.5 mm <sup>2</sup> /2x1 mm <sup>2</sup> Air and creep distance 4kV/2 DIN VDE 0110
<b>Fuse</b> An external fuse must be connected in series with the supply voltage to A1	6 A	<b>Protection class</b>	Enclosure IP 40 IEC 60529 Connection blocks IP 20 IEC 60529
<b>Max line resistance</b> at nominal voltage to X1	150 Ohm	<b>Approved standards</b>	EN ISO 13849-1/EN 954-1 EN ISO 13849-2 EN 62061 EN 61496-1, EN 574, EN 692 EN 60204-1 EN 50178 EN 61000-6-2 EN 61000-6-4 EN 61000-4- IEC/EN 61508-1...7
<b>Power consumption</b> Total current consumption	300 mA	<b>Input function 1 (two channel, normally closed circuit)</b>	Dynamic output signal T1 Dynamic input signal S1 Static input signal (+24 V) S2
<b>Input function 2 (dynamic safety circuit)</b>	Dynamic output signal T11 Dynamic input signal R11 (odd number of sensors in a circuit) R12 (even number of sensors in a circuit)	<b>Reset input X1/X11</b>	Voltage at X1/X11 when reset +24VDC Reset current 30 mA (300 mA peak during contact closure) Minimum contact closure time for reset 80 ms
<b>Number of sensors</b> Max. number of Eden or Tina units per input function 2 Total max. cable length (depending on the number of Eden/Tina units) Max. number of light beams (Spot T/R) per input function 2 Spot 10 Spot 35 Total max. cable length (depending on the number of Spot T/R)	10 500 m 1 3 100 m	Maximum number of units varies depending on the installation and cable size. For more information, see the examples in this chapter.	
<b>Response time</b> Relay output (Q1, Q11) Safe transistor outputs (Q2, Q12) Non-safe transistor output (Q2, Q12)	15 – 24 ms 11 – 20 ms 11 – 20 ms	<b>Note:</b> Connector blocks are detachable without cables having to be disconnected.	

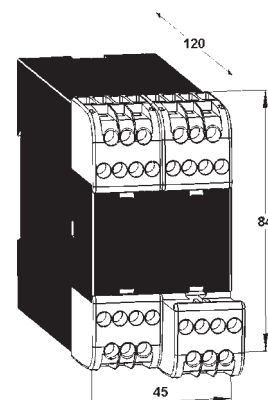

# Why should you use the Tina Adapter Units?

...to adapt safety sensors to a dynamic single-channel circuit according to PL e!

The Tina devices adapt safety sensors with mechanical contacts, such as emergency stops, switches and light grids/curtains with dual outputs to the dynamic safety circuit in Vital and Pluto.

This means Vital/Pluto complies with EN ISO 13849-1 and

SIL 3 in EN 62061 and EN 61508 for the connected safety sensors with the Vital/Pluto controller.

Note that ABB Jokab Safety's dynamic safety sensors, such as Eden and Spot can be connected directly to the Vital/Pluto circuit without intermediate Tina devices.

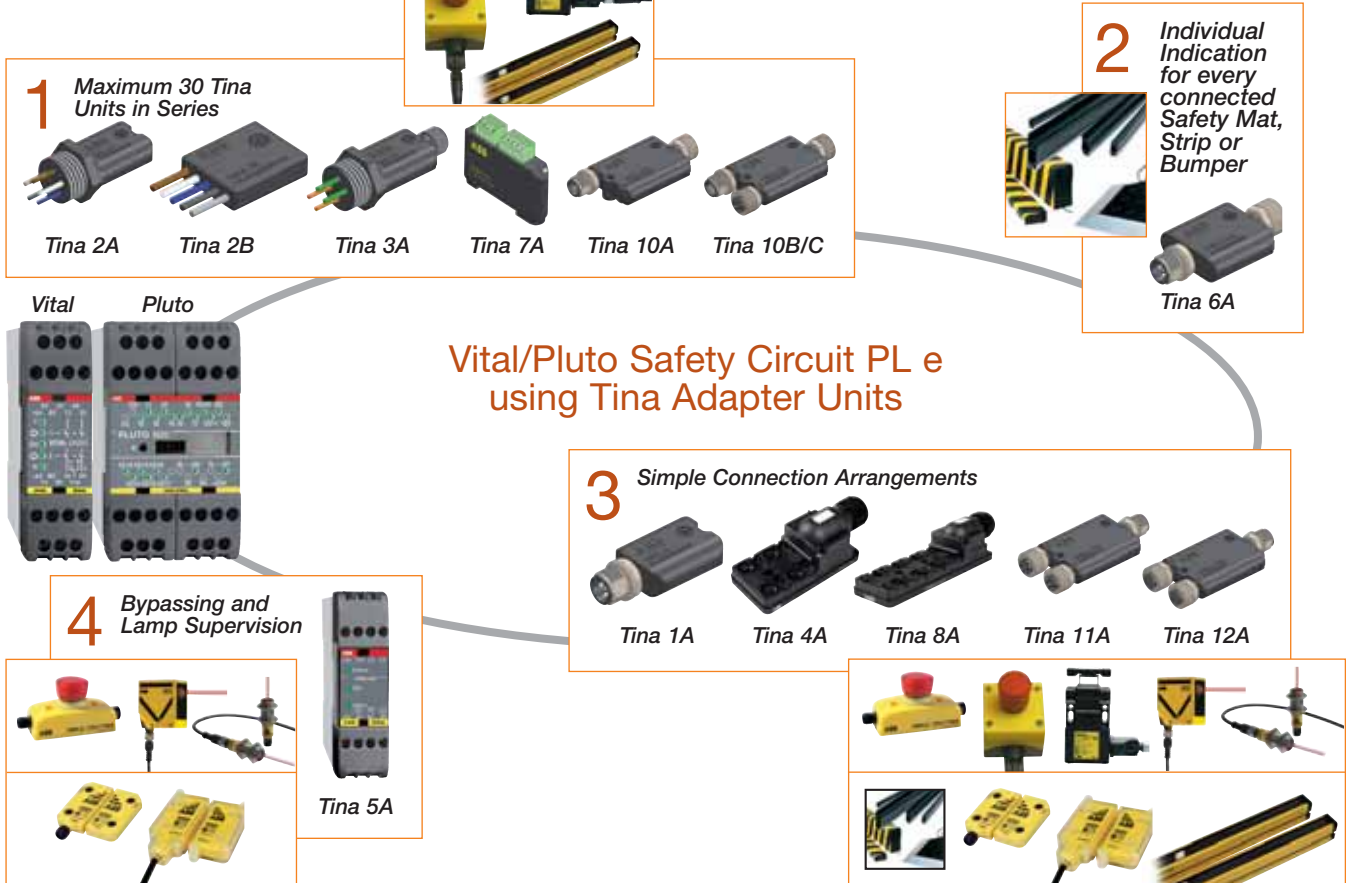

...for bypassing of safety sensor in a dynamic circuit!

The Tina 5A bypass unit is used for bypassing of safety sensor in a dynamic circuit and provides the possibility for supervision of bypass lamp indication. During bypassing of safety devices, e.g. a light grid or an interlocked gate switch/sensor, it must only be possible to allow the bypass function if a lamp indication is given. The lamp indication must therefore be supervised. With this system it is possible to bypass one or more safety sensors at the same time.

...as a connection block for simplified connection to a dynamic circuit!

The Tina 4A/8A connection blocks are available with 4 or 8 M12 connections. They are used to enable several safety sensors having M12 connection cables to be connected together. The blocks are connected with a suitable multi-core cable, that contains status information from each safety cable component, to the control cabinet. This enables simplified wiring. The connection block contains electronic circuits which modify the coded dynamic signal in the safety circuit.

*Note: Several connection blocks can be connected to one Vital/Pluto. Using Tina 4A/8A connection blocks eliminates connection faults and can significantly reduce system cable costs.*

## Available in Several Variations

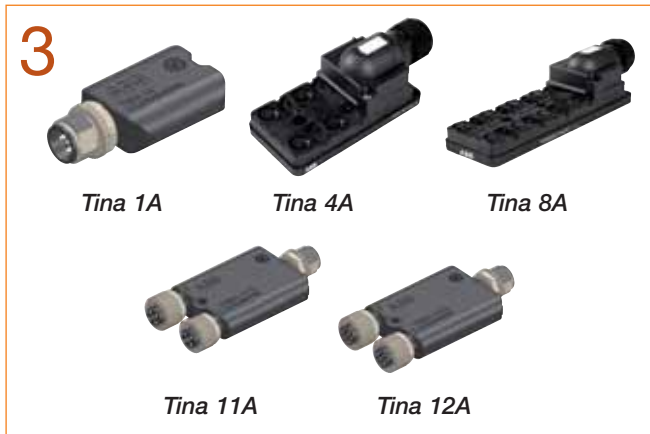
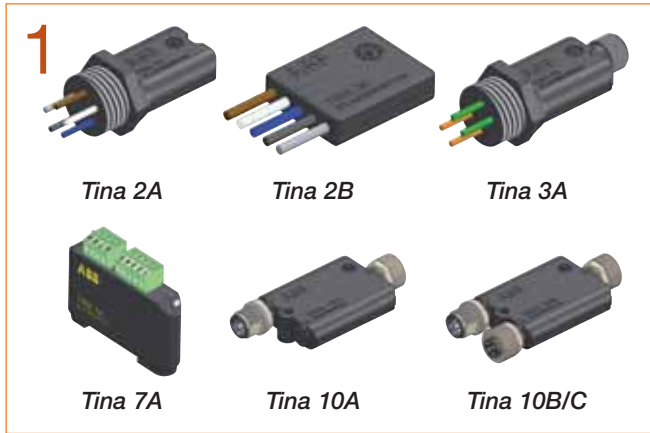

### Why should you choose Tina?

- Safety circuit, PL e, EN ISO 13849-1
- Individual status indication of every connected unit in the safety circuit
- Supervision of lamp indicating bypassing of safety device
- Quick release M12 connector

Tina is available in several versions depending on the type of safety component that is connected to the Vital or Pluto circuit. Also available is a bypassing unit, three connector blocks with 2, 4 or 8 M12 connectors, and a blind plug for un-used connections.

As an accessory there is a Y-connector for series or parallel connection and even for connection of light beams with separate transmitter and receiver. Tina units are also included in emergency stop models Smile Tina and Inca Tina. This is to adapt ABB Jokab Safety's products to dynamic safety circuits.

All Tina-units are designed to decode the dynamic signal in the safety circuit of Vital/Pluto.

**1** *Tina 2A/B*, *Tina 3A* and *Tina 7A* are used to connect safety components with mechanical contacts, such as emergency stops, switches and light curtains or light beams with relay outputs.

*Note: In order to maintain safety category 4 and to reduce the risk of electrical interference, Tina 2 A, 3A and 7A units must be installed within the same physical encapsulation as the safety component that is to be monitored, and this is to be connected to the Tina unit with as short a cable as possible.*

*Tina 10A/B/C* units are used for connection of Focus light beams/curtains to Vital or Pluto. Tina 10B has an extra M12 connector that enables reset, a reset lamp and switching of the Focus supply voltage. The Tina 10C has an additional M12 connector that permits a Focus transmitter to receive power.

**2** *Tina 6A* is used to connect door sensitive edges and safety mats, and provides an indication for each unit. (*Tina 7A* may also be used.) If a *Tina 6A* is connected close to the edge or mat, the risk of electrical interference is reduced.

**3** *Tina 4A*, *Tina 8A*, *Tina 11A* and *Tina 12A* are used as terminal blocks and simplify connection to a Vital or Pluto safety circuit. Each safety component is connected to the terminal block via an M12 connection. A terminal block is connected to the apparatus enclosure by means of a cable that also contains status information from each safety component that is connected to *Tina 4A/Tina 8A* and summed information from *Tina 11A/Tina 12A*. *Tina 1A* must be used as a blanking plug in unused M12 connections.

**4** *Tina 5A* is used to bypass the safety sensors in Vital security loop and for monitoring the indicator light switch off. *Tina 5A* bypass units are used for bypassing of safety sensors in a dynamic circuit and provides the possibility for supervision of bypass lamp indication.

# Tina 1A Blanking Plug for Connection Block

Tina 1A is a device that is designed for use with the connection blocks Tina 4A or Tina 8A where it is used as a blind plug in unused M12 connections. The device is fitted with a LED for status indication of the dynamic safety circuit.



## Application

- Used as a blanking plug in unused M12 connectors at connection blocks

## Features

- Indication of status by LED

## Approvals

TÜV Nord  

## Tina 1A Technical Data

Manufacturer	ABB AB/Jokab Safety, Sweden
Ordering information	see page 4:57
Level of safety IEC/EN 61508-1...7 EN 62061 EN ISO 13849-1 EN 954-1	SIL3 SIL3 PL e, category 4 Category 4
PFH <sub>d</sub>	4.50×10 <sup>-9</sup>
Power supply Operating voltage Total current consumption  Time delay t (in/out) Voltage supply at normal operation (protection OK) and 24 VDC supply voltage	24 VDC + +15%, -25% 17 mA (27 mA with max information output) Information output: Max 10 mA t < 60 μs Dynamic input: between 9 and 13 volt (RMS) Dynamic output: between 9 and 13 volt (RMS) Information output: ~ 23 VDC
Protection class	IP67
Ambient temperature	Storage: -30...+70°C Operation: -10...+55°C
Humidity range	35 to 85 % (with no icing or condensation)
Housing material	Based on polyamide, Macromelt OM646 (V0)
Connector	M12 5-pole male
Size	48 × 23 × 15 mm (L x W x H)
Weight	~20 g

Color	Black
Approved standards	European Machinery Directive 2006/42/EC EN ISO 12100-1:2003 EN ISO 12100-2:2003 EN 60204-1:2007 EN 954-1:1996 EN ISO 13849-1:2008 EN 62061:2005
Certificates	TÜV Nord

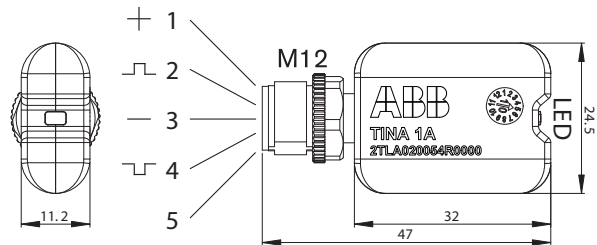

### 5-pin M12 male contact

**+24 VDC**

*Dynamic input signal*

**0 VDC**

*Dynamic output signal*

*Not used*



# Tina 2A/B Adaptation Unit

Tina 2A/B is a device that adapts the safety sensors with mechanical contacts, such as emergency stops, switches and light curtains/light grids, with their own relay outputs to the dynamic safety circuit.

Tina 2A is fitted with M20 contact which simplifies connection to safety sensors prepared for M20 connection. Tina 2B is very small and can often be placed in the safety components' enclosure. Both Tina 2A and Tina 2B are fitted with LEDs for status indication of the dynamic safety circuit.



## Applications

- Adaptation of safety sensors with mechanical contacts to the dynamic safety circuit  
Example: emergency stops, switches, light beams/light curtains with relay outputs

## Features

- Simplifies the system as well as maintaining the safety level
- Indication of status by LED

## Approvals

TÜV Nord  

## Tina 2A Technical Data

<b>Manufacturer</b>	ABB AB/Jokab Safety, Sweden
<b>Ordering information</b>	see page 4:57
<b>Level of safety</b> IEC/EN 61508-1...7 EN 62061 EN ISO 13849-1 EN 954-1	SIL3 SIL3 PL e, category 4 Category 4
<b>PFH<sub>d</sub></b>	4.50×10 <sup>-9</sup>
<b>Power supply</b> Operating voltage Total current consumption	24 VDC + 15 %, -25 % 17 mA (27 mA with max information output) Information output: Max 10 mA
Time delay t (in/out) Voltage supply at normal operation (protection OK) and 24 VDC supply voltage	t < 60 µs Dynamic input: between 9 and 13 volt (RMS) Dynamic output: between 9 and 13 volt (RMS) Information output: ~ 23 VDC
<b>Protection class</b>	IP67
<b>Ambient temperature</b>	Storage: -30...+70°C Operation: -10...+55°C
<b>Humidity range</b>	35 to 85 % (with no icing or condensation)
<b>Housing material</b>	Based on polyamide, Macromelt OM646 (V0)
<b>Connector</b>	5x0.34 mm <sup>2</sup> wires, 0.15 m
<b>Size</b>	Tina 2A: 43 × 24 × 24 mm Tina 2B: 28 × 21 × 7 mm (L x W x H)
<b>Weight</b>	Tina 2A: ~30 g Tina 2B: ~20 g
<b>Color</b>	Black

<b>Approved standards</b>	European Machinery Directive 2006/42/EC EN ISO 12100-1:2003 EN ISO 12100-2:2003 EN 60204-1:2007 EN 954-1:1996 EN ISO 13849-1:2008 EN 62061:2005
<b>Certificates</b>	TÜV Nord

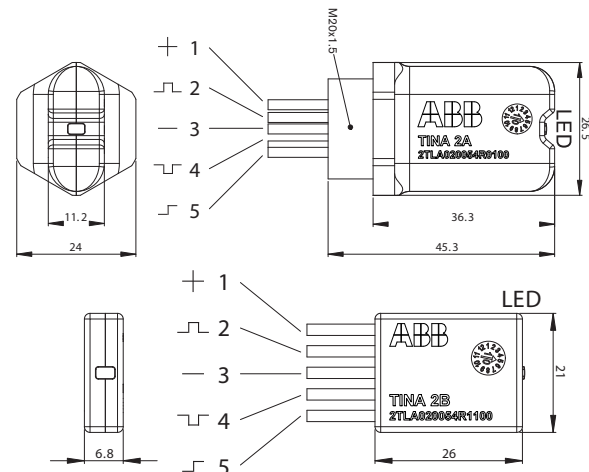

## Cable connection

- Brown: +24 VDC
- White: Dynamic input signal
- Blue: 0 VDC
- Black: Dynamic output signal
- Grey: Information

# Tina 3A/Aps Adaptation Unit

Tina 3A/Aps is a device that adapts the safety sensors with mechanical positive forced disconnecting contacts, such as emergency stops, switches and light curtains/light grids, with their own relay outputs to the dynamic safety loop.

Both Tina 3A and Tina 3Aps are fitted with M20 contacts which simplifies connection to safety sensors prepared for M20 connection. The devices are then easily connected to the dynamic safety loop through a 5-pin M12 contact to the Tina device. Tina 3Aps has an extra conductor for the supply voltage to the safety sensor.



## Applications

- Adaptation of mechanical positive forced disconnecting contacts to the dynamic safety circuit  
Example: emergency stops, switches, light beams/light curtains with relay outputs

## Features

- Simplifies the system as well as maintaining the safety level
- Indication of status by LED

## Approvals

TÜV Nord  

## Tina 3A/3Aps Technical Data

Manufacturer	ABB AB/Jokab Safety, Sweden
Ordering information	see page 4:57
Level of safety IEC/EN 61508-1...7 EN 62061 EN ISO 13849-1 EN 954-1	SIL3 SIL3 PL e, category 4 Category 4
PFH <sub>d</sub>	4.50×10 <sup>-9</sup>
Power supply Operating voltage Total current consumption	24 VDC + +15%, -25% 47 mA (57 mA with max information output) Information output: Max 10 mA
Time delay t (in/out) Current through safety device contacts Short circuit current between contacts Voltage supply at normal operation (protection OK) and 24 VDC supply voltage	t < 70 μs 12 mA 10 mA Dynamic input: between 9 and 13 volt (RMS) Dynamic output: between 9 and 13 volt (RMS) Information output: ~ 23 VDC
Protection class	IP67
Ambient temperature	Storage: -30...+70°C Operation: -10...+55°C
Humidity range	35 to 85 % (with no icing or condensation)
Housing material	Based on polyamide, Macromelt OM646 (V0)
Connectors	M12 5-pole connector Green loop wires (A1 & A2) Orange loop wires (B1 & B2) Brown (+24 VDC), Blue (0 VDC) wires (Tina 3Aps only)

Size	54 × 24 × 24 mm (L x W x H)
Weight	~30 g
Color	Black
Approved standards	European Machinery Directive 2006/42/EC EN ISO 12100-1:2003 EN ISO 12100-2:2003 EN 60204-1:2007 EN 954-1:1996 EN ISO 13849-1:2008 EN 62061:2005
Certificates	TÜV Nord

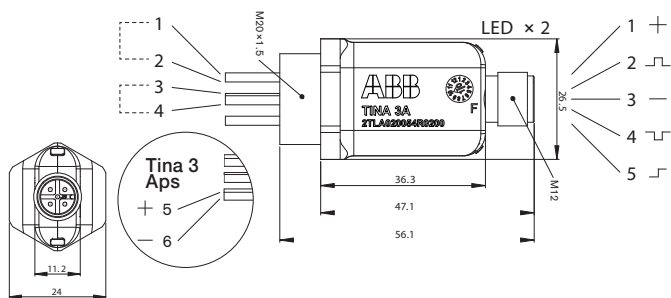

### Cable connection

**Safety circuit A1-A2**  
**Safety circuit A1-A2**  
**Safety circuit B1-B2**  
**Safety circuit B1-B2**  
**Brown: +24 VDC**  
**Blue: 0 VDC**  
**(only Tina 3Aps)**

### 5-pin M12 male contact

**+24 VDC**  
**Dynamic input signal**  
**0 VDC**  
**Dynamic output signal**  
**Not used**

# Tina 4A Connection Block

Tina 4A is a connection block with four 5-pin M12 connections. It is used to connect multiple safety sensors with M12 contacts via a single cable to a Vital controller or Pluto Safety PLC. This simplifies cable running and reduces cable costs. Multiple connection blocks can be connected to a Vital/Pluto. Tina 1A is used for unused M12 connections.



## Applications

- Connection block for up to four safety sensors adapted to the dynamic safety circuit

## Features

- Simplifies cable routing and reduces cable costs
- Allows branching of up to four safety sensors to the dynamic safety circuit

## Approvals

TÜV Nord  

## Tina 4A Technical Data

Manufacturer	ABB AB/Jokab Safety, Sweden
Ordering information	see page 4:57
Level of safety IEC/EN 61508-1...7 EN 62061 EN ISO 13849-1 EN 954-1	SIL3 SIL3 PL e, category 4 Category 4
PFH <sub>d</sub>	4.50×10 <sup>-9</sup>
Power supply Operating voltage Total current consumption  Time delay t (in/out) Voltage supply at normal operation (protection OK) and 24 VDC supply voltage	24 VDC + +15 %, -15 % 10 mA (20 mA with max information summary output) Information output: Max 10 mA t < 60 μs Dynamic input: between 9 and 13 volt (RMS) Dynamic output: between 9 and 13 volt (RMS) Information output: ~ 23 VDC
Protection class	IP67
Ambient temperature	Storage: -30...+70°C Operation: -10...+55°C
Humidity range	35 to 85 % (with no icing or condensation)
Housing material	Based on polyamide, Macromelt OM646 (V0)
Connectors	M12 5-pole female (4x) 9-pin connection block
Size	99 × 50 × 43 mm (L x W x H)
Weight	~100 g
Color	Black

Approved standards	European Machinery Directive 2006/42/EC EN ISO 12100-1:2003 EN ISO 12100-2:2003 EN 60204-1:2007 EN 954-1:1996 EN ISO 13849-1:2008 EN 62061:2005
Certificates	TÜV Nord

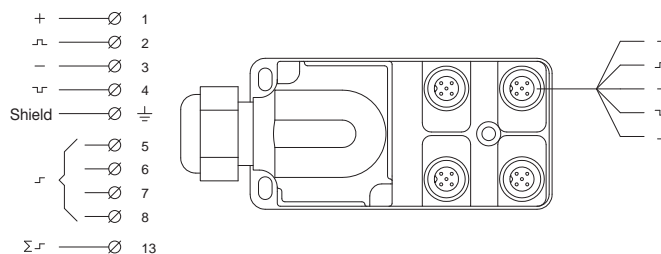

### Connection block

1. +24 VDC
2. *Dynamic input signal*
3. 0 VDC
4. *Dynamic output signal*
- ⊥ Cable shield
6. *Information (contact #1)*
7. *Information (contact #2)*
8. *Information (contact #3)*
13. *Summarized information (contact #1-4)*

### 5-pin M12 female contact (x4)

1. +24 VDC
2. *Dynamic input signal*
3. 0 VDC
4. *Dynamic output signal*
5. *Information*

# Tina 5A Adaptation Unit

## Function

The Tina 5A is designed for bypassing of safety devices connected to the Vital/Pluto safety circuit and for supervision of lamp indication.

During bypassing of safety devices, e.g. a light grid or an interlocked gate, it must only be possible to allow the bypass function if a lamp indication is on. The lamp indication must therefore be supervised. Whether indication is required depends on the specific situation and result of risk analysis.

When the Tina 5A receives a coded dynamic signal to S1 and the bypass indication lamp is on (connected across L1-L2), a bypassing output signal is provided on S2 and S3. A broken or short circuit in the indication lamp leads to an interruption of the bypass output signal on S2 and S3, therefore stopping the bypassing.

The dynamic signal to S1 on Tina 5A must be the input signal from the first of the safety devices intended to bypass. The signal can be connected via output contacts from a safety relay, a safety timer or be initiated via a unit providing the dynamic coded signal, as for example an Eden sensor or a Spot light beam. The dynamic output from S2 or S3 is connected to the output of the safeguards to be bypassed.

## S2 is used if:

- an odd number of dynamic safety units is to be bypassed using an odd number of dynamic safety units, i.e. the sum of Tina + Eden and Spot units, including Tina 5A. (See Connection Example HE3824C.)
- an even number of dynamic safety units is to be bypassed using an even number of dynamic safety units, i.e. the sum of Tina + Eden and Spot units, including Tina 5A. (See Connection Example HE3824F.)

## S3 is used if:

- an odd number of dynamic safety units is to be bypassed using an even number of dynamic safety units, i.e. the sum of Tina + Eden and Spot units, including Tina 5A. See (See Connection Example HE3824D.)
- an even number of dynamic safety units is to be bypassed using an odd number of dynamic safety units, i.e. the sum of Tina + Eden and Spot units, including Tina 5A. (See Connection Example HE3824E.)

The total number of dynamic safety units is calculated by adding the number of Eden, Spot and Tina units connected in the Vital circuit. See the Connection Examples HE3824C, D, E, F or G on pages 5:45 - 5:47.



## Application

- Bypassing of safety devices connected to the dynamic safety circuit and for supervision of lamp indication

## Features

- One or more safety devices can be bypassed
- Supervised lamp indication
- Indication of status by LED

## Approvals

TÜV Nord  

## Bypassing of Eden and Tina Units

If one or more Eden or Tina units are bypassed by a Tina 5A, a diode, such as a 1N4007, must be inserted with forward current out from pin 4 of the last bypassed unit. If one or more Eden or Tina units are bypassed by one or more Eden or Tina units direct to each other, a diode, such as a 1N4007, must be inserted by the last unit in both loops with forward current out from pin 4. Refer to example HD3801A. In the case of bypassing of a Tina 10A, B or C, or of more than one unit towards each other, it is recommended that a Tina 5A or M12-3M is used. See the Connection Examples HE3824C, D, E, F or G.

## Vital 5A Technical Data

<b>Manufacturer</b>	ABB AB/Jokab Safety, Sweden
<b>Ordering information</b>	see page 4:58
<b>Level of safety</b> IEC/EN 61508-1...7 EN 62061 EN ISO 13849-1 EN 954-1	SIL3 SIL3 PL e, category 4 Category 4
<b>PFH<sub>d</sub></b>	4.50×10 <sup>-9</sup>
<b>Power supply</b> Operating voltage Current consumption, A1-A2  Bypass connection  Time delay t (in/out) Voltage supply at normal operation (protection OK) and 24 VDC supply voltage	24 VDC + +10%, -10% No bypass: 10 mA Bypass using a 5 W indication lamp: 240 mA  Tina 5A can bypass max. 30 Eden/Tina-units or 6 Spot T/R t < 260 μs  Dynamic input: between 9 and 13 volt (RMS) Dynamic output: between 9 and 13 volt (RMS) Information output: ~ 23 VDC
<b>Protection class</b>	Enclosure: IP40 Connection block: IP20
<b>Ambient temperature</b>	-10...+55°C
<b>Humidity range</b>	35 to 85 % (with no icing or condensation)
<b>Housing material</b>	Based on polyamide, Macromelt OM646 (V0)
<b>Connectors</b>	Connection blocks with a total of 8 terminals (2 x 4)
<b>Mounting</b>	35 mm DIN rail
<b>Size</b>	120 × 84 × 22.5 mm (L x W x H)
<b>Weight</b>	~135 g
<b>Color</b>	Grey

<b>Approved standards</b>	European Machinery Directive 2006/42/EC EN ISO 12100-1:2003 EN ISO 12100-2:2003 EN 60204-1:2007 EN 954-1:1996 EN ISO 13849-1:2008 EN 62061:2005 EN 61496-1:2004 + A1:2008
<b>Certificates</b>	TÜV Nord

### Connections

- +A1:** +24 VDC
- Y14:** *Information of bypass*
- L1-L2:** *Bypass lamp (or 820 ohm/2W resistor)*
- A2:** 0 VDC
- S1:** *Dynamic signal in*
- S2:** *Dynamic signal out, transcoded*
- S4:** *Dynamic signal out, transcoded twice*

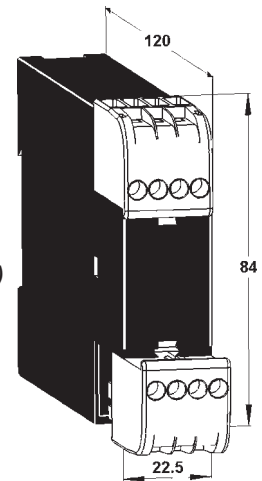

# Tina 6A Adaptation Unit

Tina 6A monitors short circuits. It is used to adapt the safety sensors with safety contact strips and safety mats with relay outputs to the dynamic safety circuit. The device is fitted with a LED for status indication of the dynamic safety circuit.



## Application

- Short circuit monitoring and adaptation of safety sensors to the dynamic safety circuit  
For example: contact edges, bumpers and safety mats

## Features

- Simplifies the system as well as maintaining the safety level
- Indication of status by LED

## Approvals

TÜV Nord  

## Tina 6A Technical Data

Manufacturer	ABB AB/Jokab Safety, Sweden
Ordering Information	see page 4:58
Level of safety IEC/EN 61508-1...7 EN 62061 EN ISO 13849-1 EN 954-1	SIL3 SIL3 PL e, category 4 Category 4
PFH <sub>d</sub>	4.50×10 <sup>-9</sup>
Power supply Operating voltage Total current consumption	24 VDC + +15%, -25% 47 mA (57 mA with max information output) Information output: Max 10 mA
Current through safety device contacts	12 mA
Short circuit current between contacts	10 mA
Time delay t (in/out)	t < 70 μs
Voltage supply at normal operation (protection OK) and 24 VDC supply voltage	Dynamic input: between 9 and 13 volt (RMS) Dynamic output: between 9 and 13 volt (RMS) Information output: ~ 23 VDC
Protection class	IP67
Ambient temperature	Storage: -30...+70°C Operation: -10...+55°C
Humidity range	35 to 85 % (with no icing or condensation)
Housing material	Based on polyamide, Macromelt OM646 (V0)
Connectors	M12 5-pole male M12 5-pole female

Size	63 × 31 × 15 (L × W × H)
Weight	~30 g
Color	Black
Approved standards	European Machinery Directive 2006/42/EC EN ISO 12100-1:2003 EN ISO 12100-2:2003 EN 60204-1:2007 EN 954-1:1996 EN ISO 13849-1:2008 EN 62061:2005
Certificates	TÜV Nord

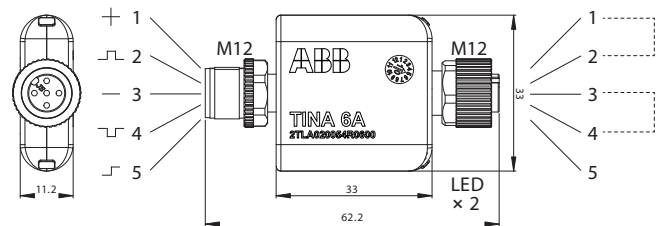

5-pin M12 male contact  
+24 VDC  
Dynamic input signal  
0 VDC  
Dynamic output signal  
Information

5-pin M12 female contact  
Safety circuit A1-A2  
Safety circuit A1-A2  
Safety circuit B1-B2  
Safety circuit B1-B2  
Not used

# Tina 7A Adaptation Unit

Tina 7A is a device that adapts the safety sensors with mechanical contacts, such as emergency stops, switches and light curtains/light grids, with their own relay outputs to the dynamic safety circuit.

The device is designed for installation in an equipment cabinet where it can be mounted directly on a 35 mm DIN rail, and the conductors are then connected directly to the screw terminals.

## Application

- Adaptation of safety controls with mechanical contacts to the dynamic safety circuit inside the same enclosure.



## Features

- Simplifies the system as well as maintaining the safety level
- Indication of status by LED
- Adapted for easy installation on 35 mm DIN rail cabinets

## Approvals

TÜV Nord  

## Tina 7A Technical Data

Manufacturer	ABB AB/Jokab Safety, Sweden
Ordering information	see page 4:58
Level of safety IEC/EN 61508-1...7 EN 62061 EN ISO 13849-1 EN 954-1	SIL3 SIL3 PL e, category 4 Category 4
PFH <sub>d</sub>	4.50×10 <sup>-9</sup>
Power supply Operating voltage Total current consumption	24 VDC + +15%, -25% 47 mA (57 mA with max information output) Information output: Max 10 mA
Current through safety device contacts	12 mA
Short circuit current between contacts	10 mA
Time delay t (in/out)	t < 70 μs
Voltage supply at normal operation (protection OK) and 24 VDC supply voltage	Dynamic input: between 9 and 13 volt (RMS) Dynamic output: between 9 and 13 volt (RMS) Information output: ~ 23 VDC
Protection class	IP20
Ambient temperature	Storage: -30...+70°C Operation: -10...+55°C
Humidity range	35 to 85 % (with no icing or condensation)
Housing material	Based on polyamide, Macromelt OM646 (V0)
Connectors	5-pin connection block (power supply, dynamic in/out, info) 4-pin connection block (safety loop A1-A2, B1-B2) Max length on leads connected to terminals 6, 7, 8 and 9 is 200mm

Mounting	DIN rail
Size	61 × 46 × 14 (L × W × H)
Weight	~35 g
Color	Black
Approved standards	European Machinery Directive 2006/42/EC EN ISO 12100-1:2003 EN ISO 12100-2:2003 EN 60204-1:2007 EN 954-1:1996 EN ISO 13849-1:2008 EN 62061:2005
Certificates	TÜV Nord

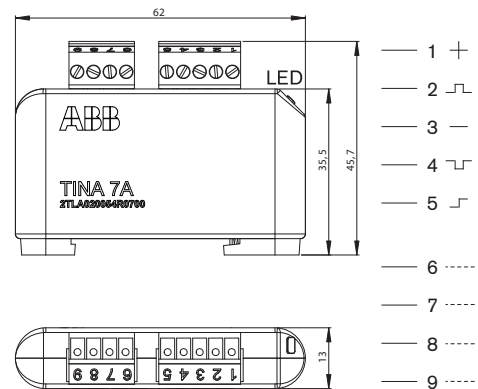

## Connection block

+24 VDC  
Dynamic input signal  
0 VDC  
Dynamic output signal  
Information

Safety circuit A1-A2  
Safety circuit A1-A2  
Safety circuit B1-B2  
Safety circuit B1-B2

# Tina 8A Connection Block

Tina 8A is a connection block with eight 5-pin M12 connections. It is used to connect multiple safety sensors with M12 contacts via a single cable to a Vital controller or Pluto PLC. This simplifies cable running and reduces cable costs. Multiple connection blocks can be connected to a Vital/Pluto. Tina 1A is used for unused M12 connections.



## Application

- Short circuit monitoring and adaptation of connection block for up to eight safety sensors adapted to the dynamic safety circuit

## Features

- Simplifies cable routing and reduces cable costs
- Allows branching of up to four safety sensors to the dynamic safety circuit

## Approvals

TÜV Nord  

## Tina 8A Technical Data

Manufacturer	ABB AB/Jokab Safety, Sweden
Ordering information	see page 4:58
Level of safety IEC/EN 61508-1...7 EN 62061 EN ISO 13849-1 EN 954-1	SIL3 SIL3 PL e, category 4 Category 4
PFH <sub>d</sub>	4.50×10 <sup>-9</sup>
Power supply Operating voltage Total current consumption	24 VDC + +15%, -15% 15 mA (25 mA with max information summary output) Information output: Max 10 mA
Time delay t (in/out) Voltage supply at normal operation (protection OK) and 24 VDC supply voltage	t < 60 μs Dynamic input: between 9 and 13 volt (RMS) Dynamic output: between 9 and 13 volt (RMS) Information output: ~ 23 VDC
Protection class	IP67
Ambient temperature	Storage: -30...+70°C Operation: -10...+55°C
Humidity range	35 to 85 % (with no icing or condensation)
Housing material	Based on polyamide, Macromelt OM646 (V0)
Connectors	M12 5-pole female (8x) 13-pin connection block
Size	149 × 50 × 43 (L × W × H)
Weight	~140 g
Color	Black

Approved standards	European Machinery Directive 2006/42/EC EN ISO 12100-1:2003 EN ISO 12100-2:2003 EN 60204-1:2007 EN 954-1:1996 EN ISO 13849-1:2008 EN 62061:2005
Certificates	TÜV Nord

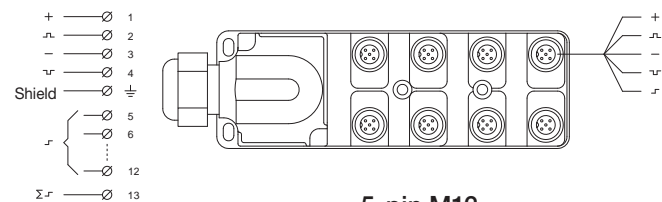

### Connection block

1. +24 VDC
2. Dynamic input signal
3. 0 VDC
4. Dynamic output signal
- ⊥ Cable shield
5. Information (contact #1)
6. Information (contact #2)
7. Information (contact #3)
8. Information (contact #4)
9. Information (contact #5)
10. Information (contact #6)
11. Information (contact #7)
12. Information (contact #8)
13. Summarized information (contact #1-8)

### 5-pin M12 female contact (x8)

- +24 VDC
- Dynamic input signal
- 0 VDC
- Dynamic output signal
- Information



## Connection Examples of Safety Sensors to Tina 8A

### Connection 1

One Eden is connected directly to the Tina 8A. The Eden status is shown by an LED on the Adam sensor. A status information signal is also connected to Tina 8A.

### Connection 2

One Focus safety light grid/curtain is connected to the Tina 8A via a Tina 10A. The output from the Tina 10A is via a M12 connector. The connection between Tina 10A and Tina 8A is achieved using a cable with M12 connectors on each end.

The Tina 10A has two LEDs which show the status of the light grid. The same status information signal is connected to the Tina 8A. Tina10A and the Focus transmitter are connected to Tina 8A via an M12-3B.

### Connection 3

A Spot 10 light beam is connected directly to Tina 8A. A 'Y' connector M12-3B for M12 plugs is connected to the transmitter and the receiver. The status information shown on the Spot LED is also connected to Tina 8A.

### Connection 4

A safety mat is connected via a Tina 6 A to the Tina 8A. (A safety strip or safety bumper is connected in the same manner.) Two LEDs in Tina 6A shows the status of the mat. The same status information signal is connected to Tina 8A.

### Connection 5

One Smile is connected to the Tina 8A. The information shown by an LED on the Smile is also connected to the terminal block on the Tina 8A.

### Connection 6

A safety interlock switch is connected via a Tina 3A mounted directly on the switch. The output from the Tina 3A is via a M12 connector. The connection between the Tina 3A and the Tina 8A is therefore simply made with a cable with M12 connectors on each end. On the Tina 3A there is a LED which shows the status of the switch. The same information signal is connected to the Tina 8A.

### Connection 7

A Spot 35, transmitter and receiver are connected directly to to the Tina 8A via a M12-3B 'Y' connector. The status information shown by the LED on the Spot is also connected to the Tina 8A.

### Connection 8

Tina 1A is a plug which has to be connected to Tina 8A inputs when no sensor is required, in order to complete the safety connection circuit.

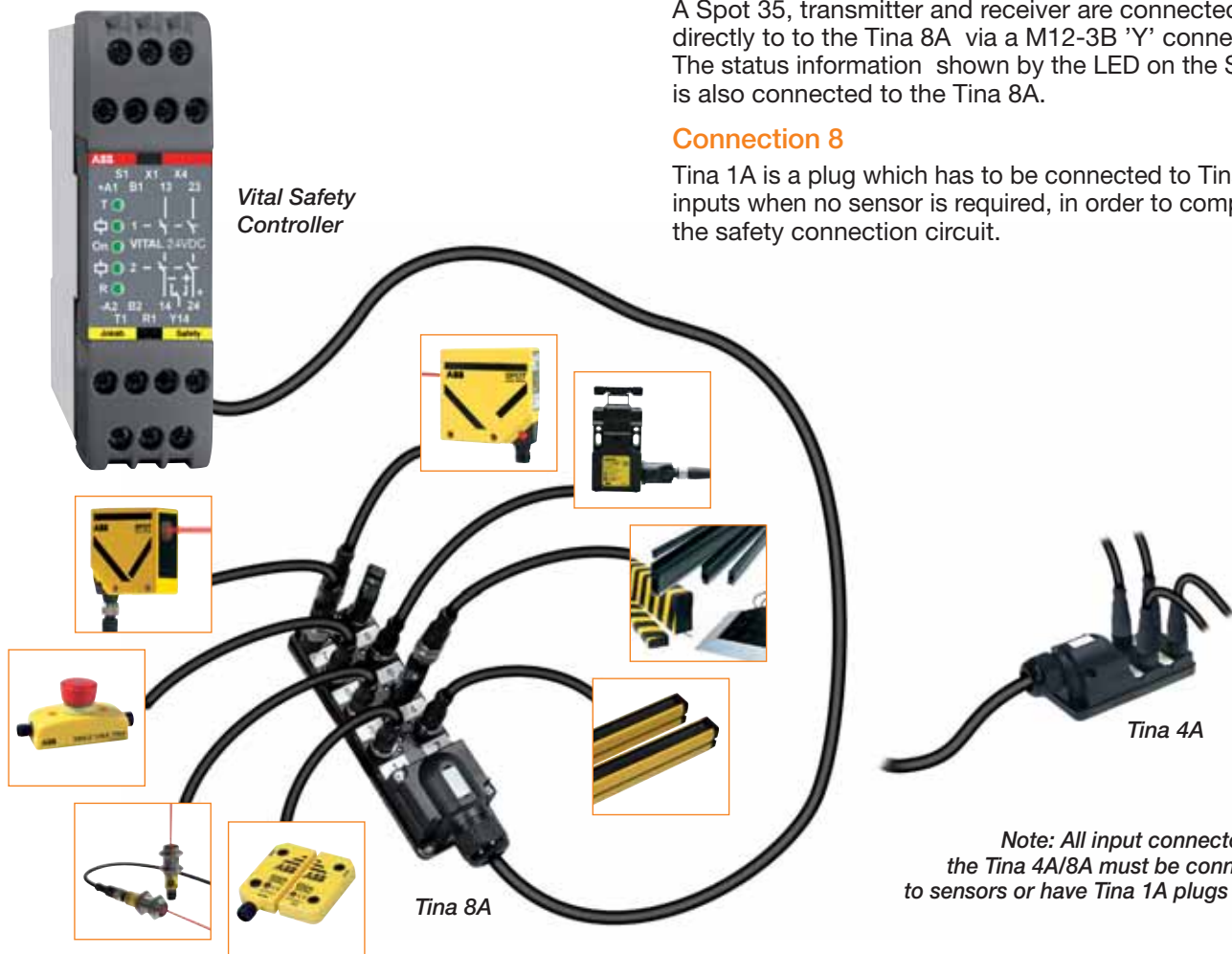

*Note: All input connectors on the Tina 4A/8A must be connected to sensors or have Tina 1A plugs fitted.*

# Tina 10A/B/C Adaptation Unit



Tina 10 A/B/C are three connection units with M12 connections, that make it easy to connect a light curtain or light beam Focus with OSSD outputs to the dynamic safety circuits of Vital and Pluto. This also enables complete external interconnections, with M12 cabling, which reduces the cabling to and connections in the apparatus enclosure. Tina 10 A/B/C has LEDs for function indication, with green, red or flashing green/red indications.

**Tina 10A** has two M12 connections that are connected to: 1) Vital/Pluto and 2) a light curtain/light beam Focus receiver. See the Connection Example HR7000L-01 on page 6:36.

**Tina 10B** has three M12 connections that are connected to: 1) Vital/Pluto and 2) a light curtain/light beam Focus receiver, and 4: An external reset button and muting lamp, such as unit FMI-1C. See the Connection Examples HR7000L-01 on page 6:36.

**Tina 10C** has three M12 connections that are connected to: 1) Vital/Pluto and 2) a light curtain/light beam Focus receiver, and 4: a light curtain/light beam Focus Transmitter. See the Connection Examples HH3302D on page 4:49, HR7000L-01 on page 6:36.

## Application

- Adaptation of safety sensors with OSSD outputs to the dynamic safety circuit. For example: Focus light curtain/light beam

## Features

- Simplifies the system as well as maintaining the safety level
- Indication of status by LED

## Approvals

TÜV Nord  

## Tina 10A, 10B and 10C Connections

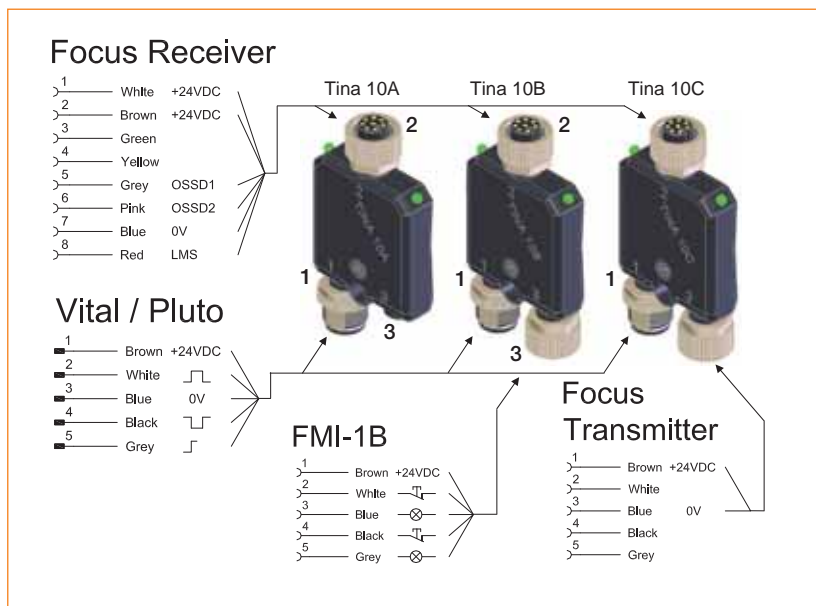

## Tina 10A, 10B and 10C Technical Data

<b>Manufacturer</b>	ABB AB/Jokab Safety, Sweden
<b>Ordering information</b>	see page 4:58
<b>Level of safety</b> IEC/EN 61508-1...7 EN 62061 EN ISO 13849-1 EN 954-1	SIL3 SIL3 PL e, category 4 Category 4
<b>PFH<sub>d</sub></b>	4.50×10 <sup>-9</sup>
<b>Power supply</b> Operating voltage Total current consumption  Time delay t (in/out) Voltage supply at normal operation (protection OK) and 24 VDC supply voltage	24 VDC + +20%, -20% 60 mA (70 mA with max. info signal out) Info signal out: Max. 10 mA  t < 120 μs Dynamic input signal: 9 to 13 V (RMS) Dynamic output signal: 9 to 13 V (RMS) Info signal out: ~23 VDC
<b>Protection class</b>	IP67
<b>Ambient temperature</b>	Storage: -10...+55° C Operation: -10...+55° C
<b>Humidity range</b>	35 to 85 % (without icing or condensation)
<b>Housing material</b>	Based on polyamide, Macromelt OM646 (V0)
<b>Size</b>	74 × 36 × 11 mm (L × W × H)
<b>Weight</b>	~40 g
<b>Color</b>	Black
<b>Number of units connected to Vital 1</b> Max. number of Tina 10A: Max. number of Tina 10B/C:	6 4 when Focus is supplied by Vital and a reset lamp is used 6 when Focus is supplied separately or no reset lamp is used
<b>Number of units connected to Pluto, Vital 2 or 3, per input</b> Max. number of Tina 10A/B/C:	2
<b>Connectors</b> Tina 10A  Tina 10B  Tina 10C	1: for Vital or Pluto 2: for Focus receiver  1: for Vital or Pluto 2: for Focus receiver 3: for Reset unit  1: for Vital or Pluto 2: for Focus receiver 3: for Focus transmitter

<b>Approved standards</b>	European Machinery Directive 2006/42/EC EN ISO 12100-1:2003 EN ISO 12100-2:2003 EN 60204-1:2007 EN 954-1:1996 EN ISO 13849-1:2008 EN 62061:2005 EN 61496-1:2004 + A1:2008
<b>Certificates</b>	TÜV Nord CE

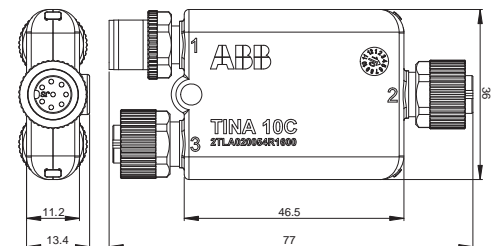
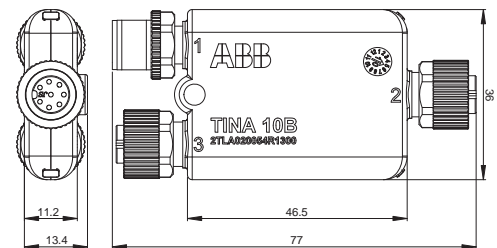
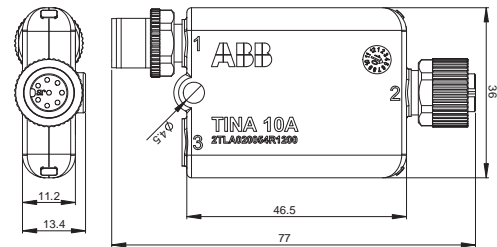

# Tina 11A Terminal Block



Tina 11A is a connection block with two 5-pin M12 connections. It is used to connect two safety sensors with M12 contacts via a single cable to a Vital controller or Pluto Safety PLC. This simplifies cable running and reduces cable costs. Multiple connection blocks can be connected to a Vital/Pluto.

## Application

- Terminal block for connection of two safety sensors with 5-pin M12 connectors and adaptation to the dynamic safety circuit

## Features

- Simplifies cable routing and reduces cable costs
- Allows connection of two safety sensors to the dynamic safety circuit

## Approvals

TÜV Nord  

## Tina 11A Technical Data

Manufacturer	ABB AB/Jokab Safety, Sweden
Ordering information	see page 4:58
Level of safety IEC/EN 61508-1...7 EN 62061 EN ISO 13849-1 EN 954-1	SIL3 SIL3 PL e, category 4 Category 4
PFH <sub>d</sub>	4.50×10 <sup>-9</sup>
Power supply Operating voltage Total current consumption  Time delay t (in/out) Voltage supply at normal operation (protection OK) and 24 VDC supply voltage	24 VDC + +15%, -15% 17 mA (27 mA with max information output) Information output: Max 10 mA t < 60 μs Dynamic input: between 9 and 13 volt (RMS) Dynamic output: between 9 and 13 volt (RMS) Information output: ~ 23 VDC
Protection class	IP67
Ambient temperature	Storage: -30...+70°C Operation: -10...+55°C
Humidity range	35 to 85 % (with no icing or condensation)
Housing material	Based on polyamide, Macromelt OM646 (V0)
Connectors	Out: M12 5-pole male (nr 2) In: M12 5-pole female (nr 1.3)
Size	74 × 36 × 11 mm (L × W × H)
Weight	~40 g
Color	Black

Approved standards	European Machinery Directive 2006/42/EC EN ISO 12100-1:2003 EN ISO 12100-2:2003 EN 60204-1:2007 EN 954-1:1996 EN ISO 13849-1:2008 EN 62061:2005
Certificates	TÜV Nord

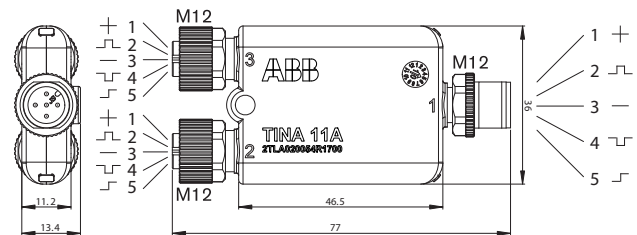

**5-pin M12 female connector (contact #2-3)**  
+24 VDC  
Dynamic input signal  
0 VDC  
Dynamic output signal  
Information

**5-pin M12 male connector (contact #1)**  
+24 VDC  
Dynamic input signal  
0 VDC  
Dynamic output signal  
Summarized information (contact #2-3)

# Tina 12A Terminal Block

Tina 12A is a connection block with two 8-pin M12 connections. It is used to connect two process locks (Dalton or Magne 2A/B) with integrated Eden sensors via a single cable to a Vital controller or Pluto Safety PLC. This simplifies cable running and reduces cable costs. Multiple connection blocks can be connected to a Vital/Pluto.

Tina 12A has three 8-pin M12 contacts that connect to: 1) Pluto/Vital, information for sensors and locks and lock signals, 2) Dalton with Eden No 1 and 3) Dalton with Eden No 2.



## Application

- Terminal block for connection of two safety sensors with 8-pin M12 connectors and adaptation to the dynamic safety circuit  
For example: Dalton, Magne and Knox

## Features

- Simplifies cable routing and reduces cable costs
- Allows connection of two safety sensors to the dynamic safety circuit

## Approvals



## Tina 12A Technical Data

Manufacturer	ABB AB/Jokab Safety, Sweden
Ordering information	see page 4:58
Level of safety IEC/EN 61508-1...7 EN 62061 EN ISO 13849-1 EN 954-1	SIL3 SIL3 PL e, category 4 Category 4
PFH <sub>d</sub>	4.50×10 <sup>-9</sup>
Power supply Operating voltage Total current consumption	24 VDC + +15%, -15% 60 mA (70 mA with max information output) Information output: Max 10 mA
Time delay t (in/out) Voltage supply at normal operation (protection OK) and 24 VDC supply voltage	t < 60 μs Dynamic input: between 9 and 13 volt (RMS) Dynamic output: between 9 and 13 volt (RMS) Information output: ~ 23 VDC
Protection class	IP67
Ambient temperature	Storage: -30...+70°C Operation: -10...+55°C
Humidity range	35 to 85 % (with no icing or condensation)
Housing material	Based on polyamide, Macromelt OM646 (V0)
Connectors	To Vital/Pluto: M12 8-pole male (nr 2) From safety device: M12 8-pole female (nr 1.3)

Size	74 × 36 × 11 mm (L × W × H)
Weight	~40 g
Color	Black
Approved standards	European Machinery Directive 2006/42/EC EN ISO 12100-1:2003 EN ISO 12100-2:2003 EN 60204-1:2007 EN 954-1:1996 EN ISO 13849-1:2008 EN 62061:2005
Certificates	TÜV Nord

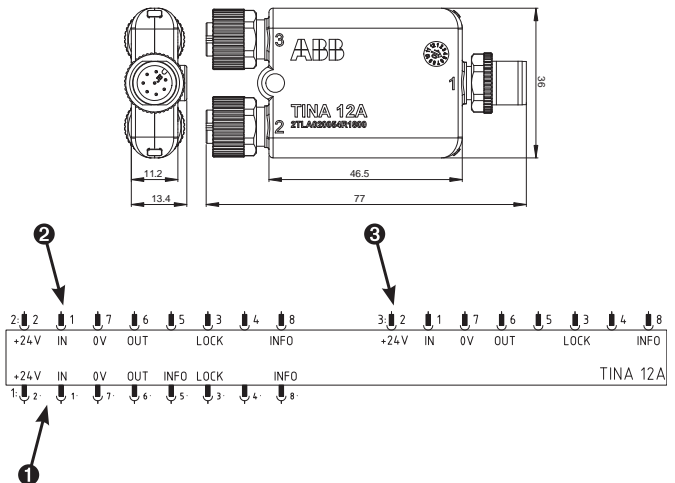

## Accessories

'Y' branch with M12 connection and M12-connection device with screw connectors

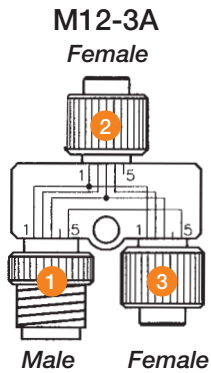

See the  
Connection Examples  
HA3306C, D – pages 5:42, 5:43  
HH3300A, D – page 5:48

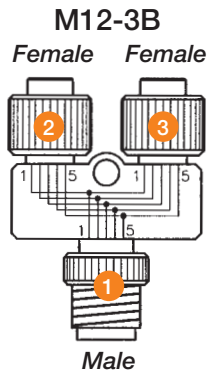

See the  
Connection Examples  
HA3306C, D – pages 5:42, 5:43  
HH3300D – page 5:48  
HH3302D – page 5:49

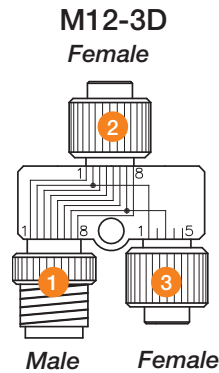

See the  
Connection Examples  
HR7000L – page 5:36  
HR7000O – page 5:37

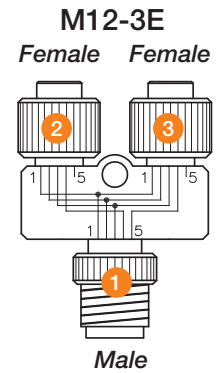

See the  
Connection Examples  
HB0001A, 2A, 4A and 6A  
pages 5:51, 5:52, 5:53

Note: See product list for applications

M12-C01

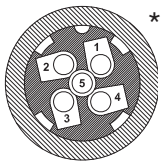

Female

M12-C02

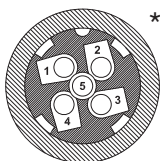

Male

M12-C03

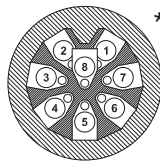

Female

M12-C04

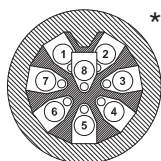

Male

\* Seen from the cable connection side

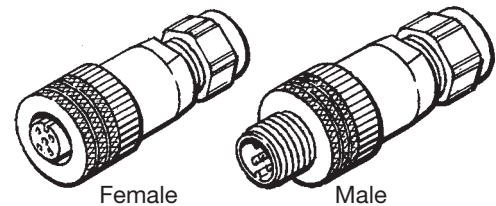

Female

Male

## Cabling

Many of ABB Jokab Safety's products are connected using standard M12 connectors. This facilitates installation, saving a lot of time, and also dramatically reducing the risk of incorrect connection.

We have therefore developed cables with 5 conductors (5 x 0.34 mm + screening) or 8 conductors (8 x 0.34 mm + screening) which offer the advantages that we believe a good cable should have. These are available in any length and in various standard lengths, with molded straight or angled male or female connectors. Particularly suitable cables for the Tina 4A and Tina 8A units are C9 and C13. They have thicker, 0.75 mm<sup>2</sup> conductors for the feed line and 0.5 mm<sup>2</sup> for the other conductors + screening. Refer to the component list for the variants that are available.



### Advantages

- Area 0.34 mm<sup>2</sup>
- Always screened cable
- The screen is always connected to negative in male connectors
- The guide pin in the small connector is indicated by a recessed arrow that is easy to recognize
- Convenient cable in PVC
- The cable is also available in any length

## Example of Safety Component Connections based on 'Y' Branch

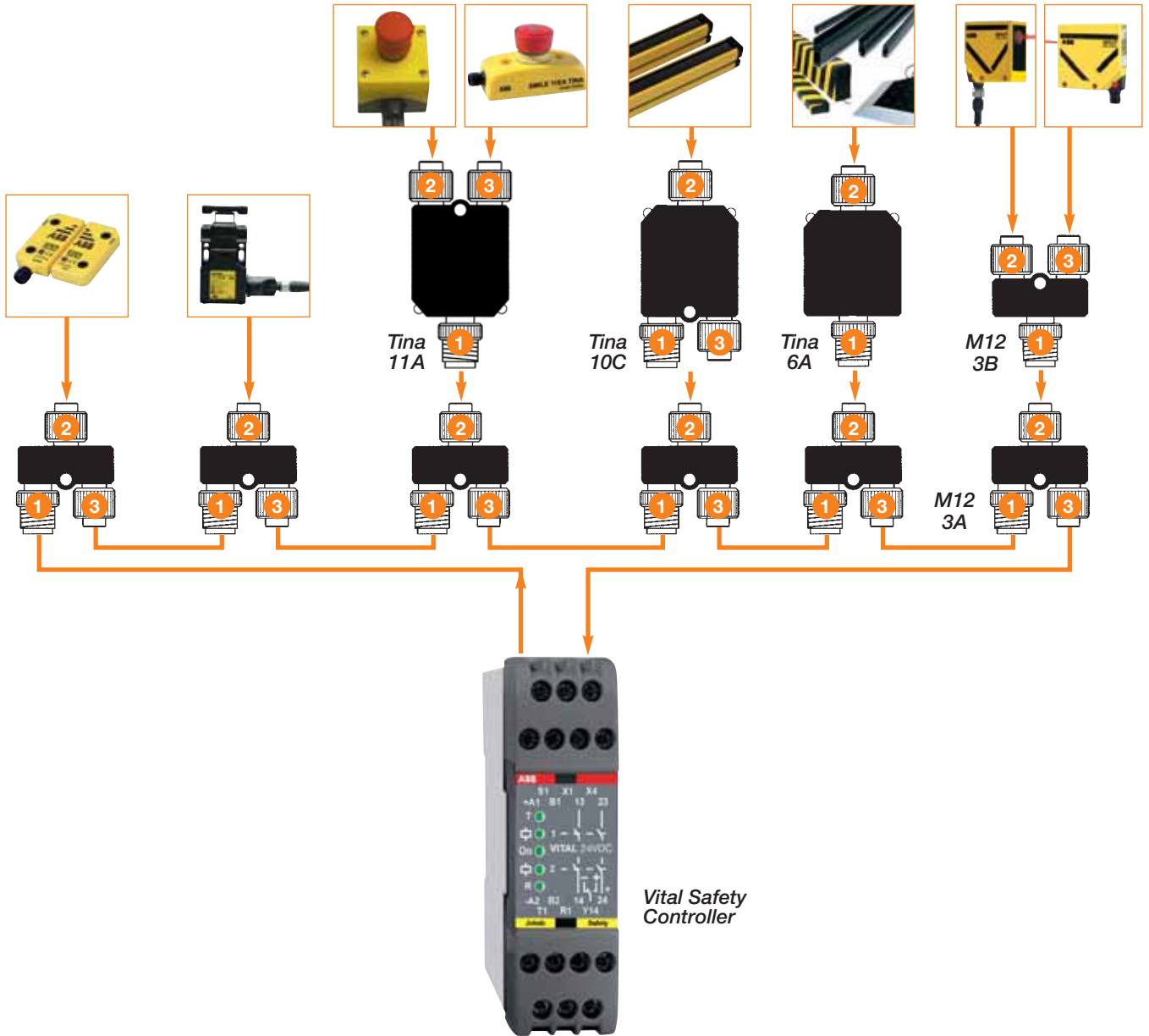

# Connection Examples Contents

<b>HA3300A-01</b> Connection Example Vital 1.....	4:41	<b>HH3300A</b> Vital 1 with Different Types of Safety Devices and M12-3A.....	4:50
<b>HA3301A</b> Vital 1 with Several Eden.....	4:41	<b>HH3300D</b> Vital 1 with Tina 4A and Different Types of Safety Devices.....	4:50
<b>HA3302A</b> Vital 1 and Tina 4A with 4 Eden.....	4:42	<b>HH3302D</b> Vital 1 with Tina 8A and Different Types of Safety Devices.....	4:51
<b>HA3302B</b> Vital 1 and 2 Tina 4A and 4 Eden and Emergency Stop.....	4:42	<b>HH3301E</b> Connection Example Vital 1.....	4:51
<b>HA3303A</b> Vital 1 with Emergency Stop/Tina 2A.....	4:43	<b>HH3400A2</b> Vital 1 Solutions.....	4:52
<b>HA3304A</b> Vital 1 with Emergency Stop/Tina 3A.....	4:43	<b>HB0005A</b> Vital with Eden and Inca Emergency Stop, with Separate Reset.....	4:52
<b>HA3305A</b> Vital 1 with Eden and Focus Light Grid/Tina 10C.....	4:44	<b>HB0006A</b> Vital with 4 Eden Units + Reset via M12-3E and Tina 4A.....	4:53
<b>HA3306C</b> Vital 1 with 2 Spot Light Beams.....	4:44	<b>HB0007A</b> Vital with Two Dalton Units via Tina 12A.....	4:53
<b>HA3306D</b> Vital 1 with 3 Spot Light Beams.....	4:45	<b>HB0001A</b> Pluto with Smile Emergency Stop Unit + Reset via M12-3E and Adam via Tina 4A.....	4:54
<b>HA3307A</b> Vital 1 with Eden, Light Grid/Tina 3A and Emergency Stop/Tina 7A.....	4:45	<b>HB0002A</b> Pluto with Five Eden Units, for Two Zones via M12-3E and Tina 4A.....	4:54
<b>HD3800A-01</b> Vital 1 with Spot Safety Light Beam.....	4:46	<b>HB0003A</b> Pluto with Smile and Inca Emergency Stop Units, via Tina 11A and Tina 4A.....	4:55
<b>HD3801A-01</b> Vital 1, Series and Parallel.....	4:46	<b>HB0004A</b> Pluto with Different Zones for Eden + Reset and Two Eden units + via M12-3E.....	4:55
<b>HE3811B-01</b> Safety Light Beam Spot with Time-Limited Reset.....	4:47	<b>HH3301D</b> Connection Example – Vital 1 and Tina 8A with Different Safety Device Types.....	4:56
<b>HE3824C-01</b> Light Beam with Time-Limited Bypass 0.2–40 s.....	4:47		
<b>HE3824D-01</b> Eden and Bypassed Light Beam with Eden.....	4:48		
<b>HE3824E-01</b> Light Beams with Time-Limited Bypass 0.2–40 s.....	4:48		
<b>HE3824F-01</b> Eden and 2 Bypass Light Beams with Eden.....	4:49		
<b>HE3824G-01</b> Eden and 2 Separately Bypassed Light Beams.....	4:49		



# HA3300A-01 Connection Example

## Vital 1

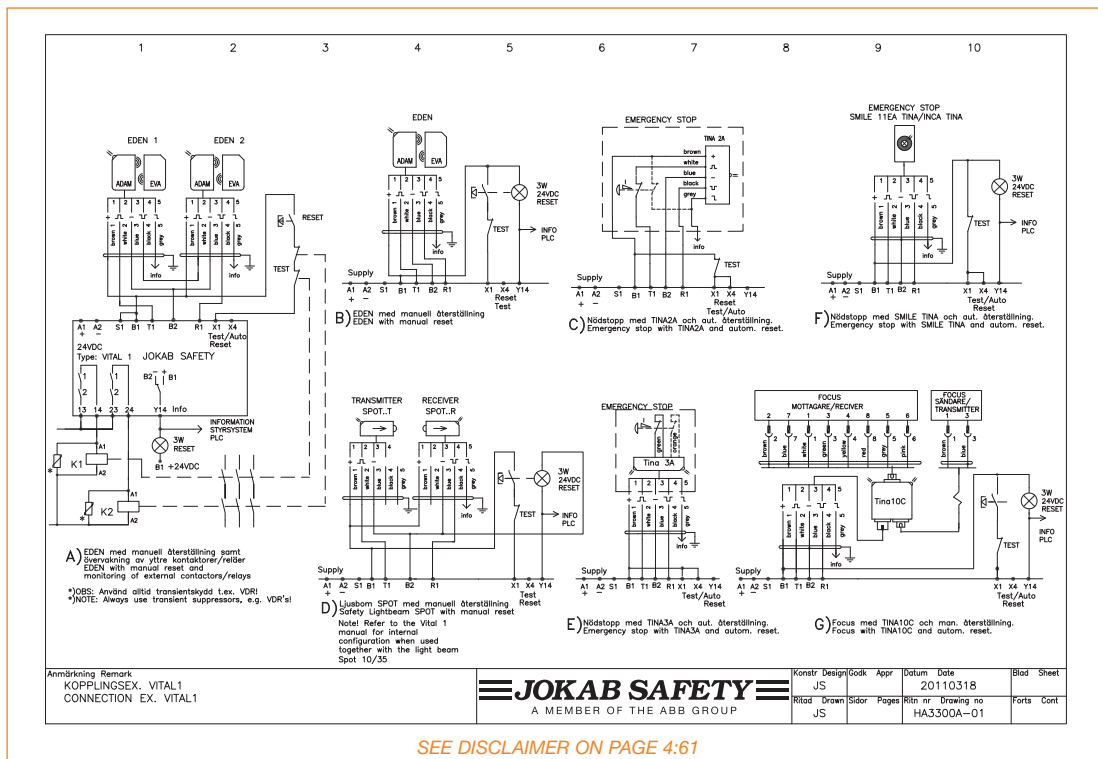

# HA3301A Vital 1 Connection Example

## Vital 1 with Several Eden

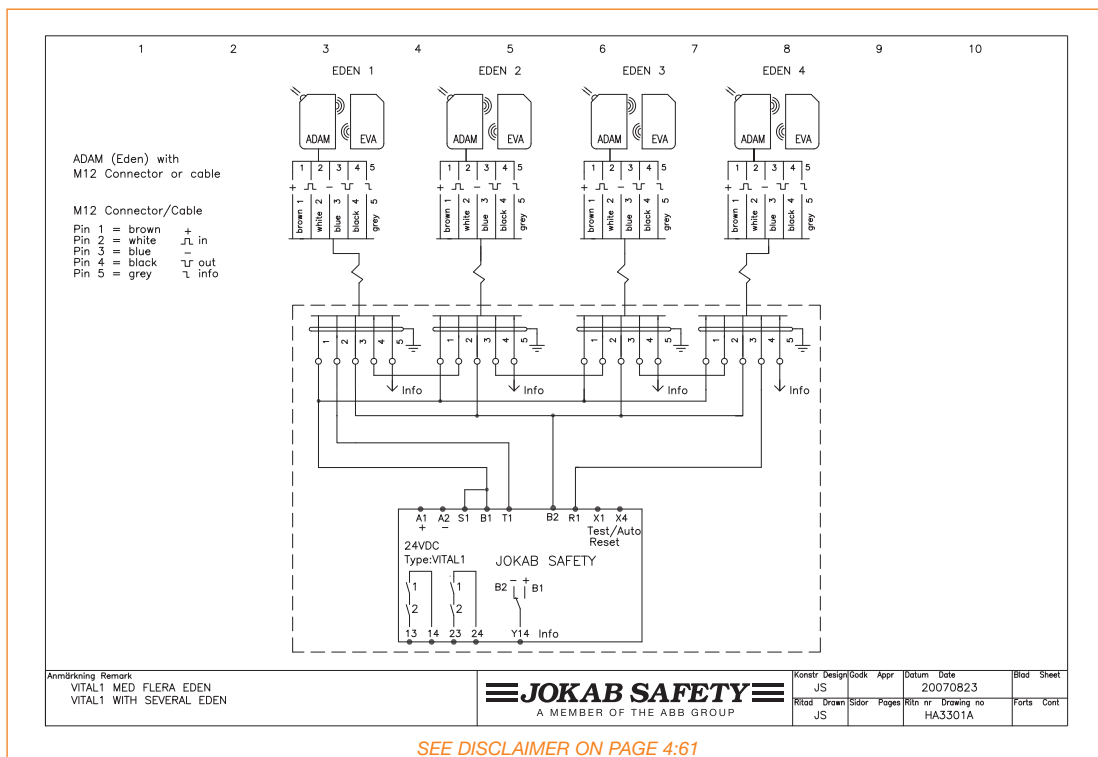

# HA3302A Connection Example

## Vital 1 and Tina 4A with 4 Eden

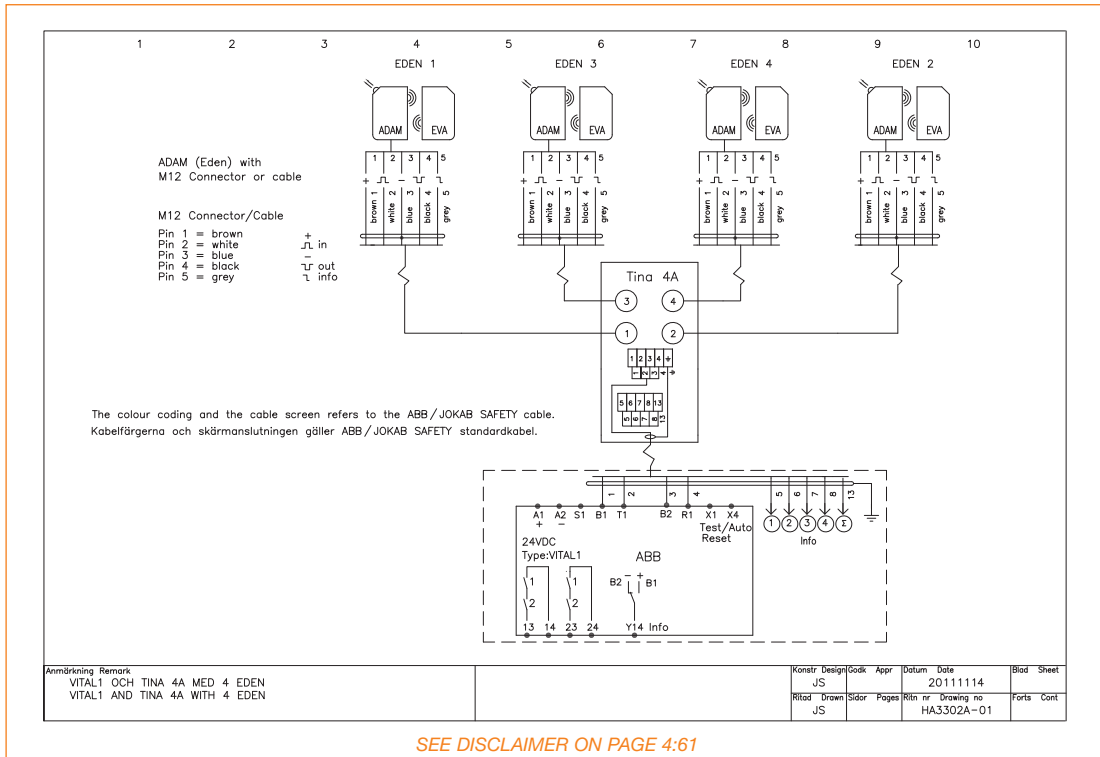

# HA3302B Connection Example

## Vital 1 and 2 Tina 4A and 4 Eden and Emergency Stop

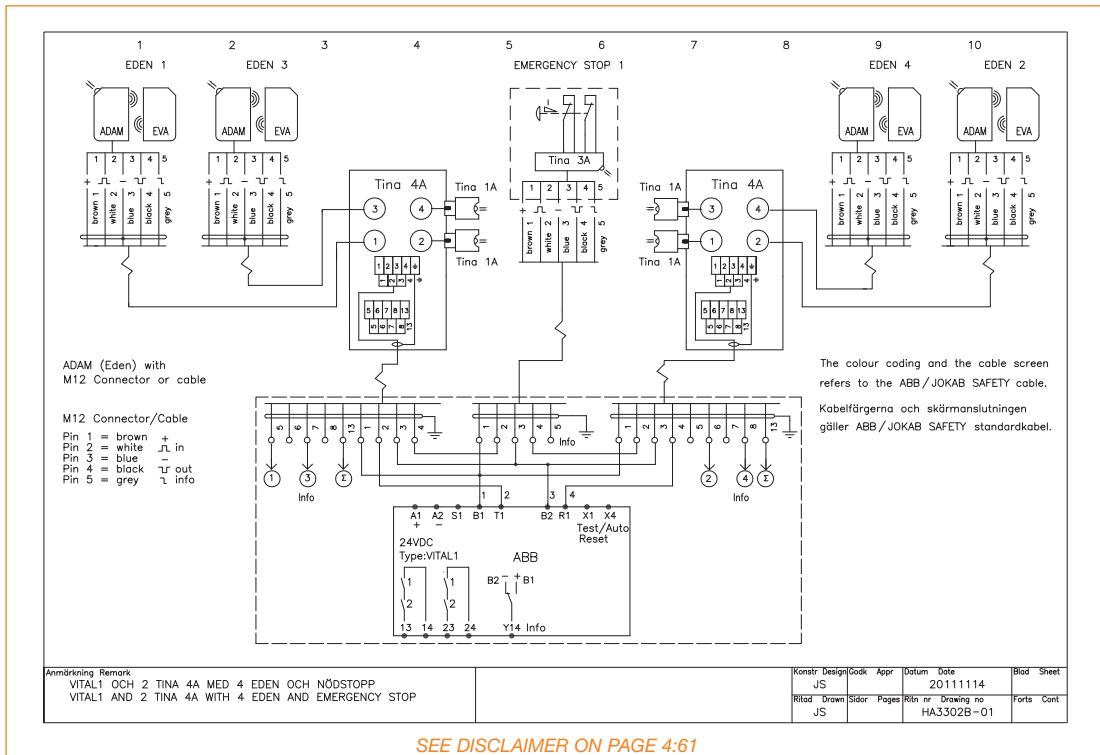

# HA3303A Connection Example

## Vital 1 with Emergency Stop/Tina 2A

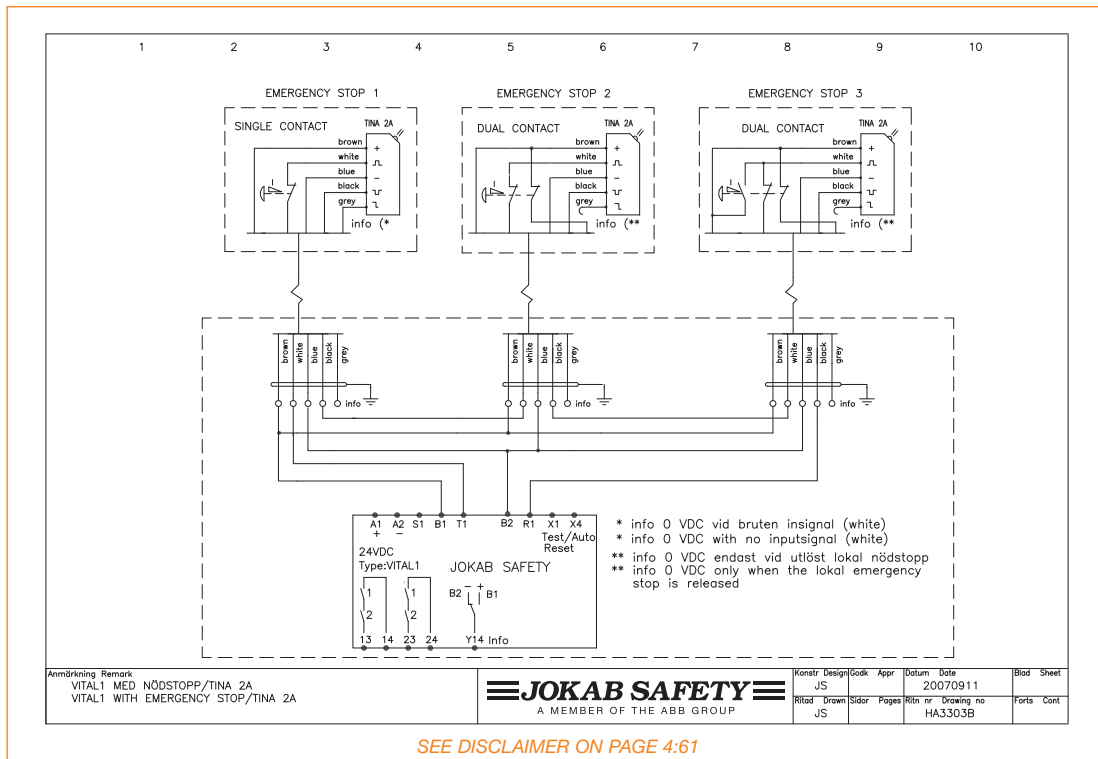

# HA3304A Connection Example

## Vital 1 with Emergency Stop/Tina 3A

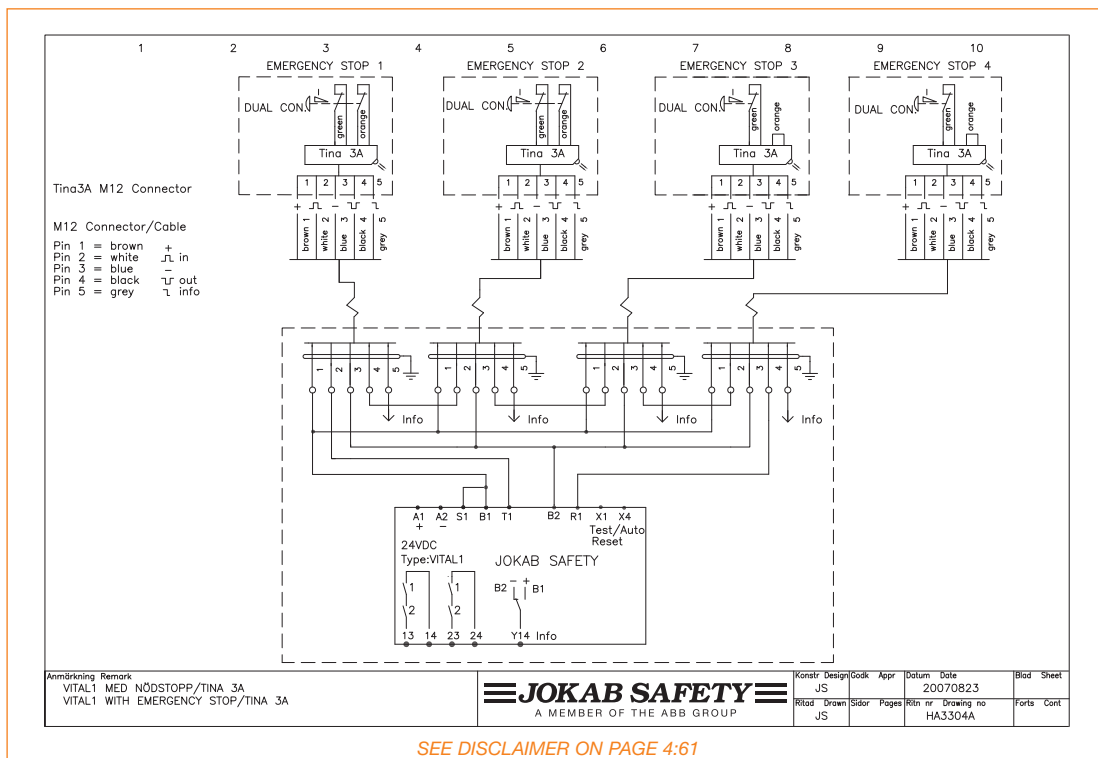

# HA3305A Connection Example

## Vital 1 with Eden and Focus Light Grid/Tina 10C

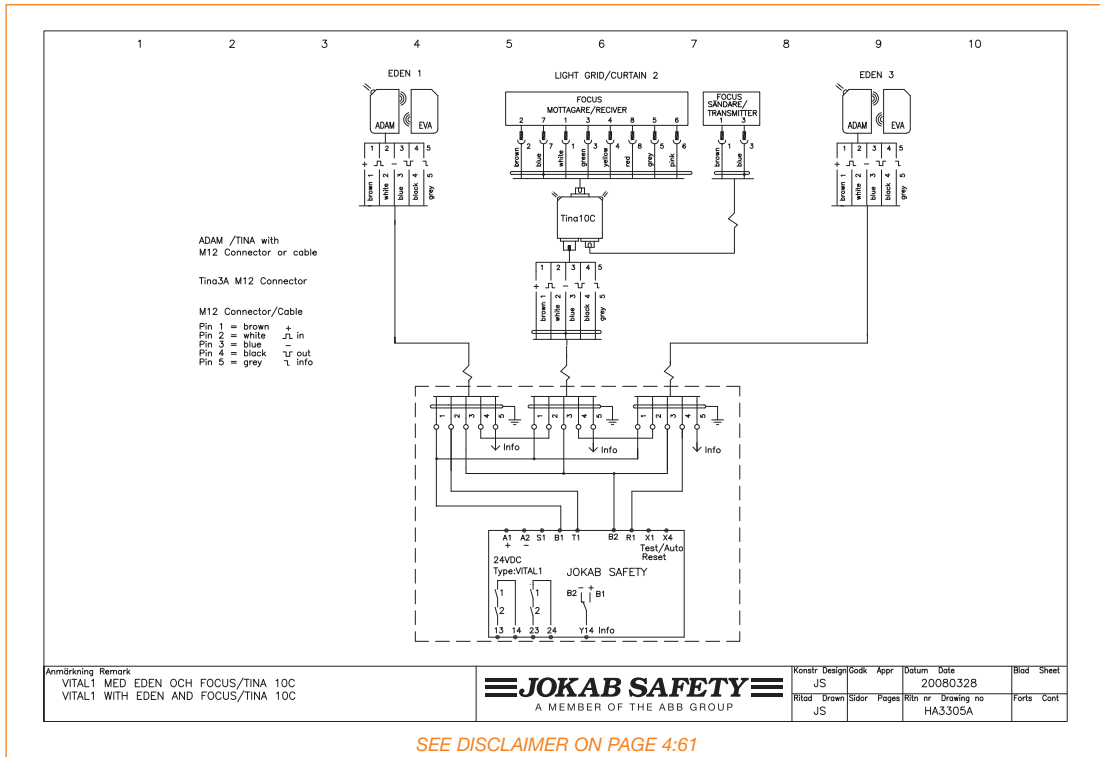

# HA3306C Connection Example

## Vital 1 with 2 Spot Light Beams

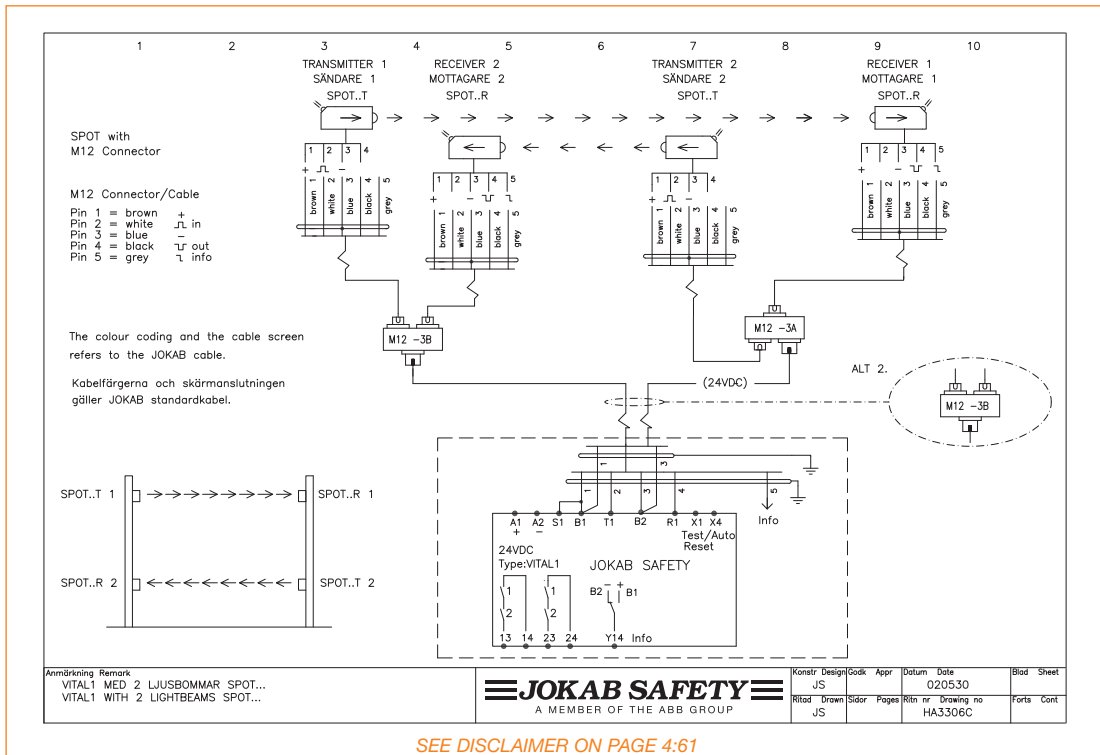

# HA3306D Connection Example

## Vital 1 with 3 Spot Light Beams

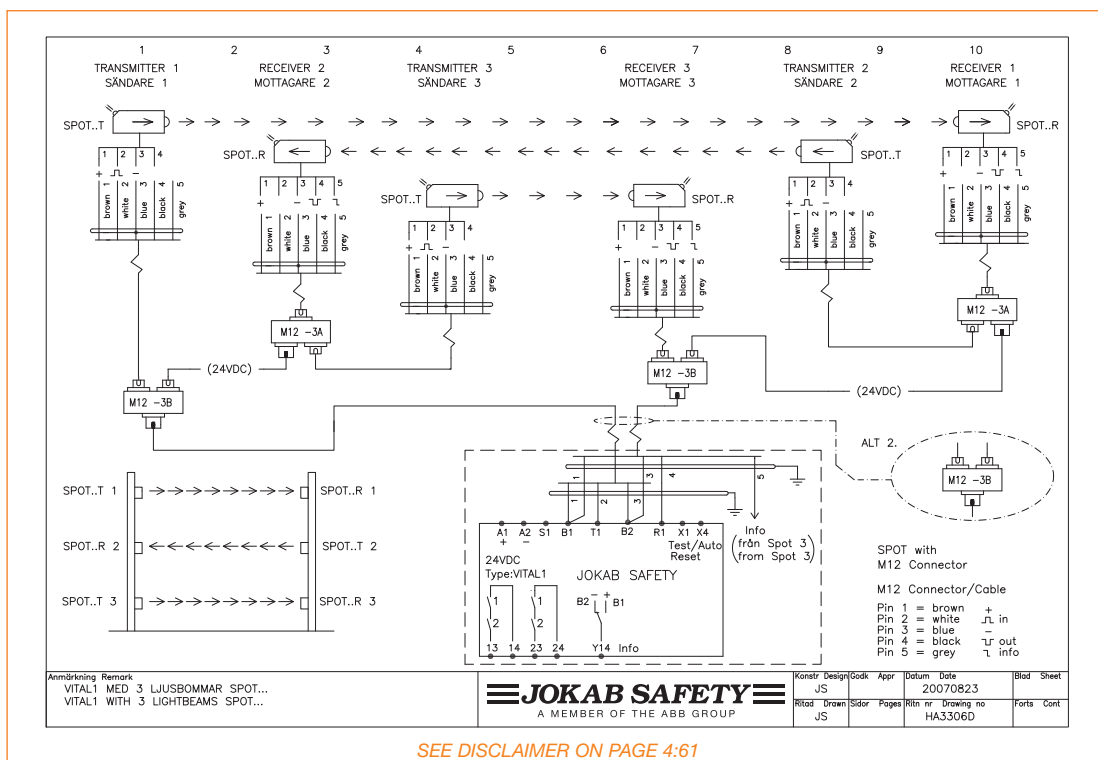

# HA3307A Connection Example

## Vital 1 with Eden, Light Grid/Tina 3A and Emergency Stop/Tina 7A

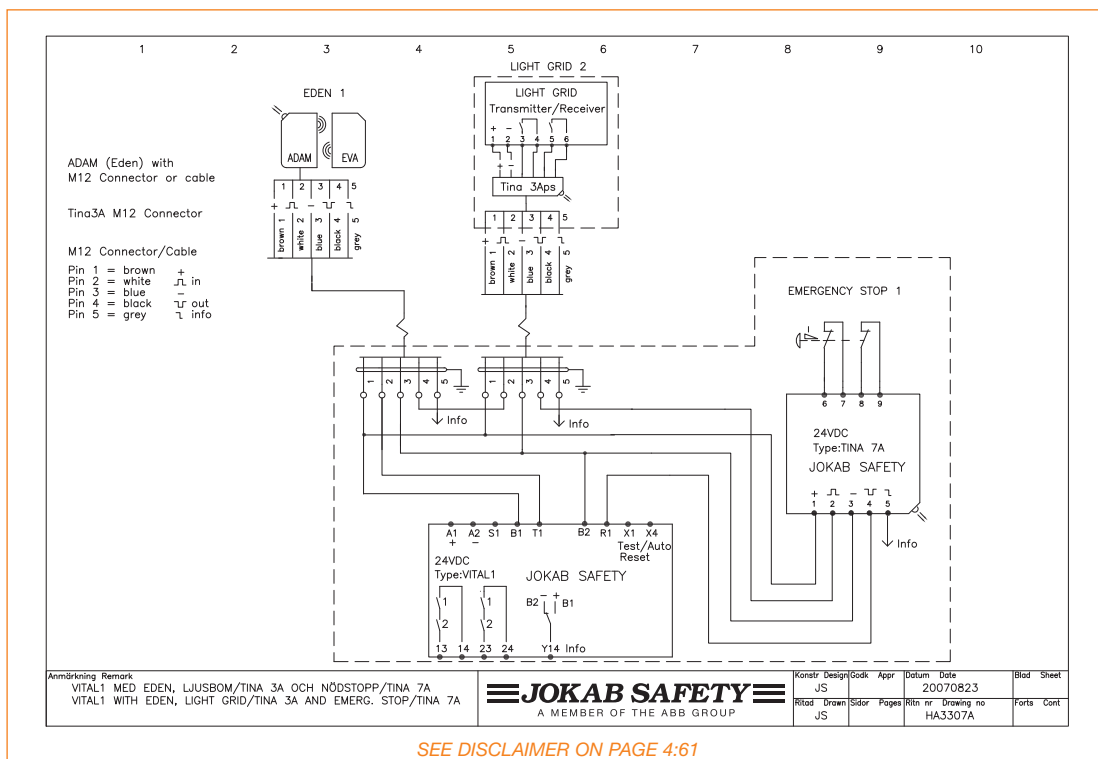

# HD3800A-01 Connection Example

## Vital 1 with Spot Safety Light Beam

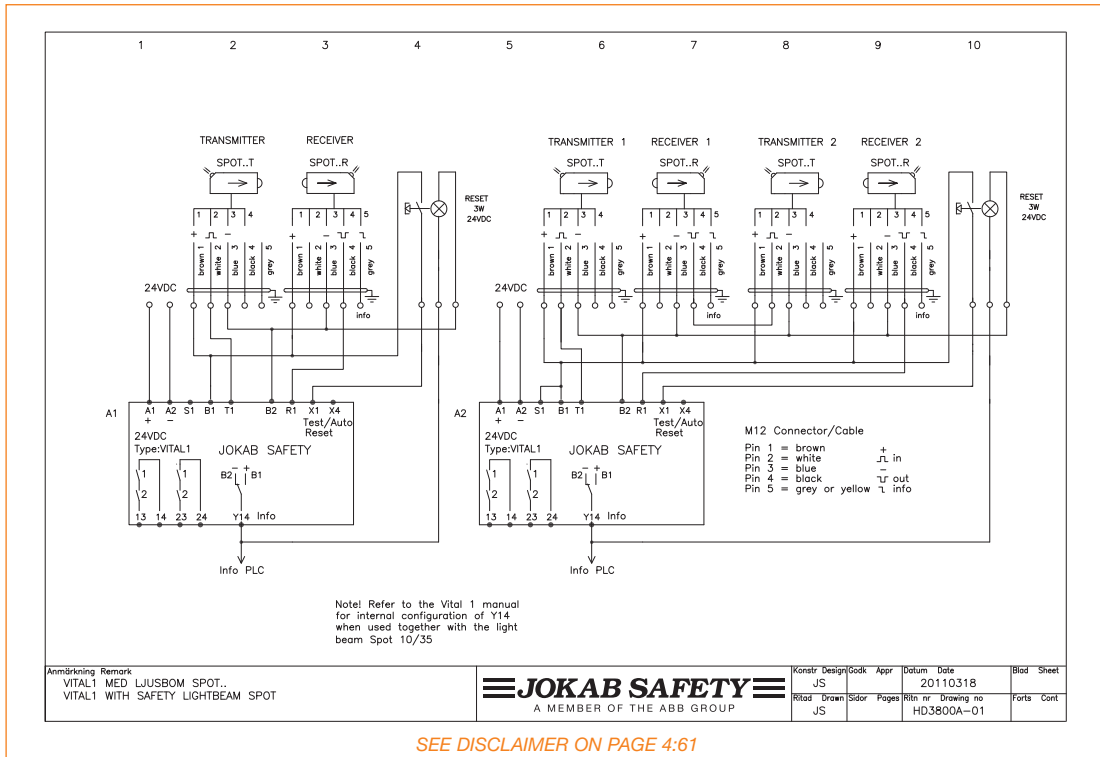

# HD3801A-01 Connection Example

## Vital 1, Series and Parallel

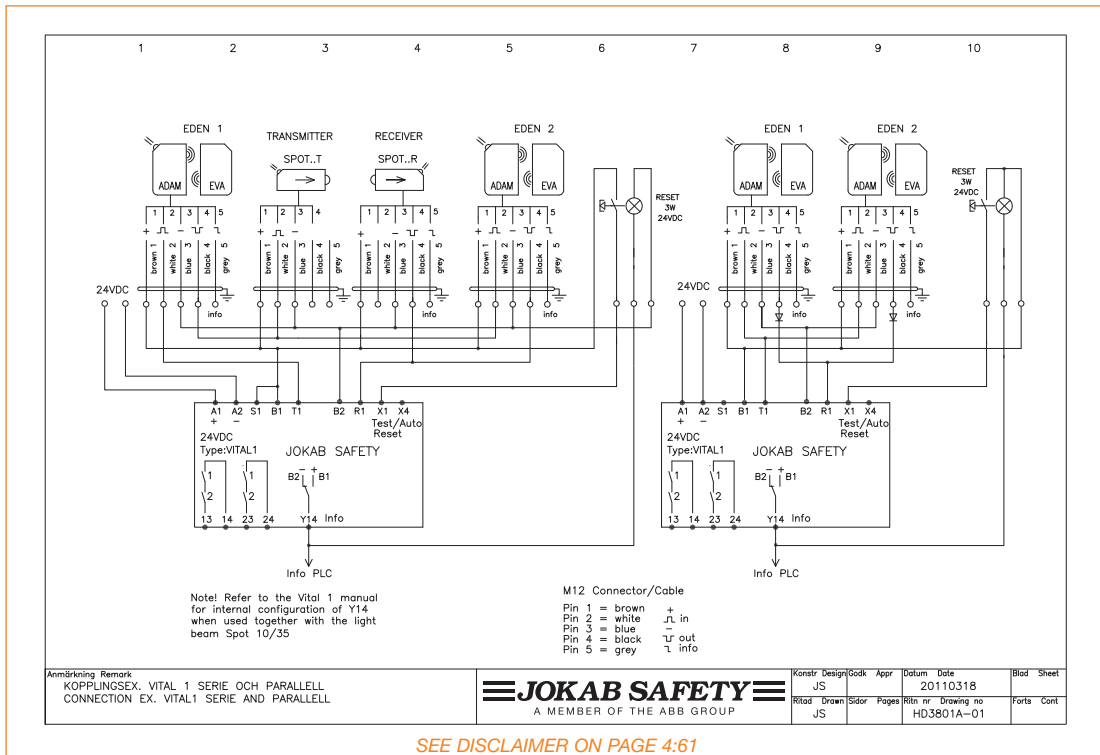

# HE3811B-01 Connection Example

## Safety Spot Light Beam with Time-Limited Reset

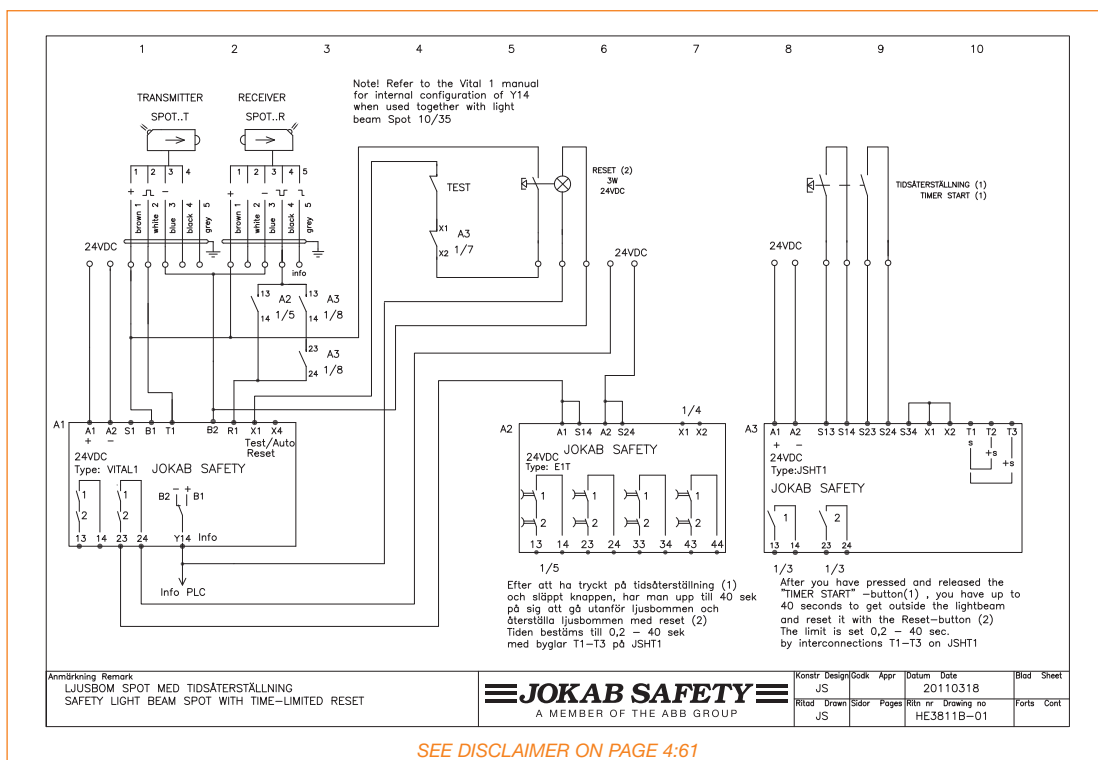

# HE3824C-01 Connection Example

## Light Beam with Time-Limited Bypass 0.2–40 s

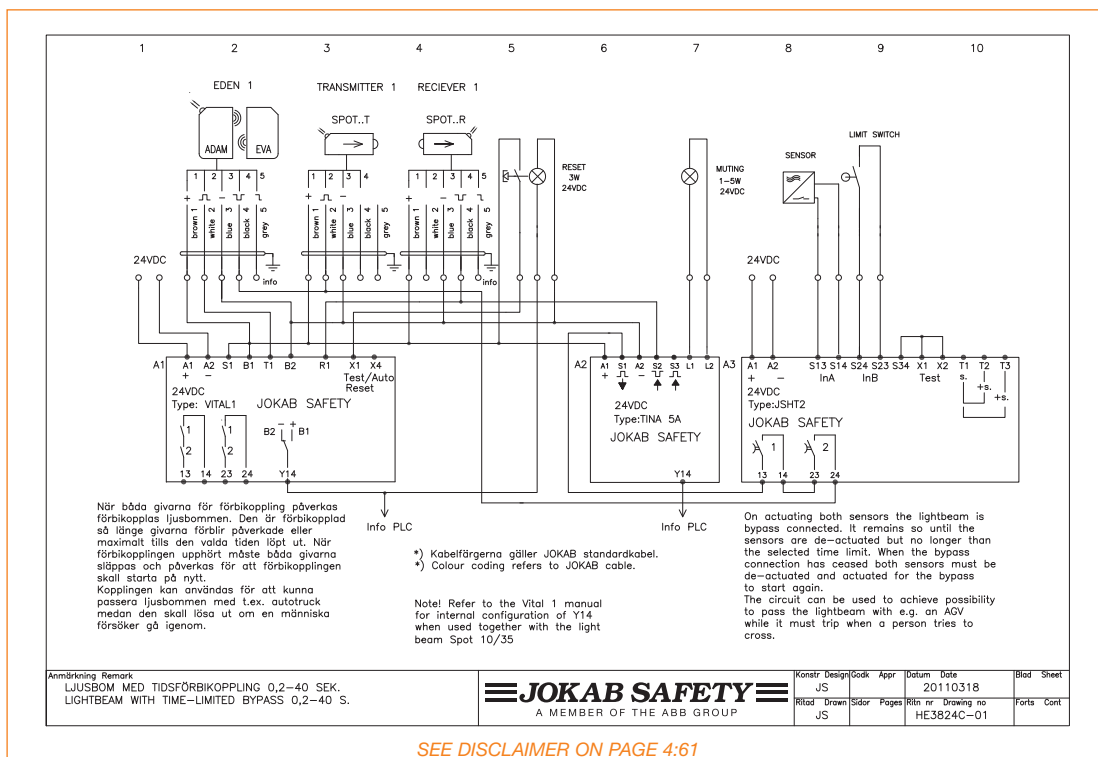

# HE3824D-01 Connection Example

## Eden and Bypassed Light Beam with Eden

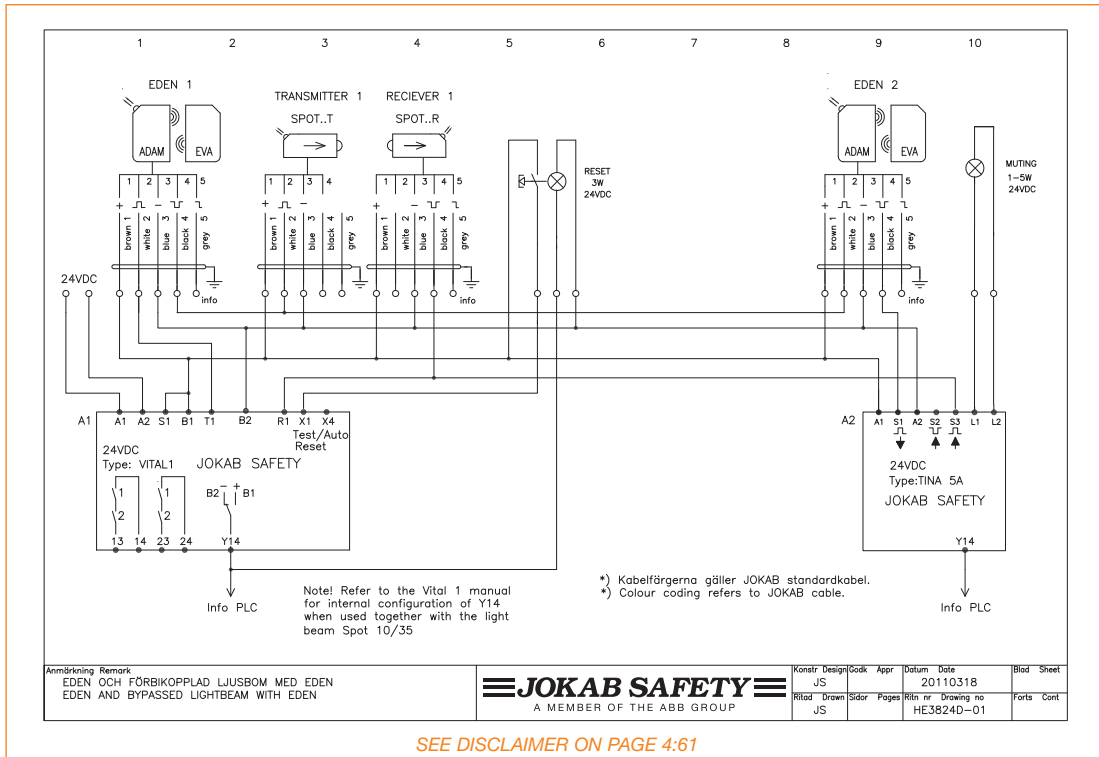

# HE3824E-01 Connection Example

## Light Beams with Time-Limited Bypass 0.2-40 s

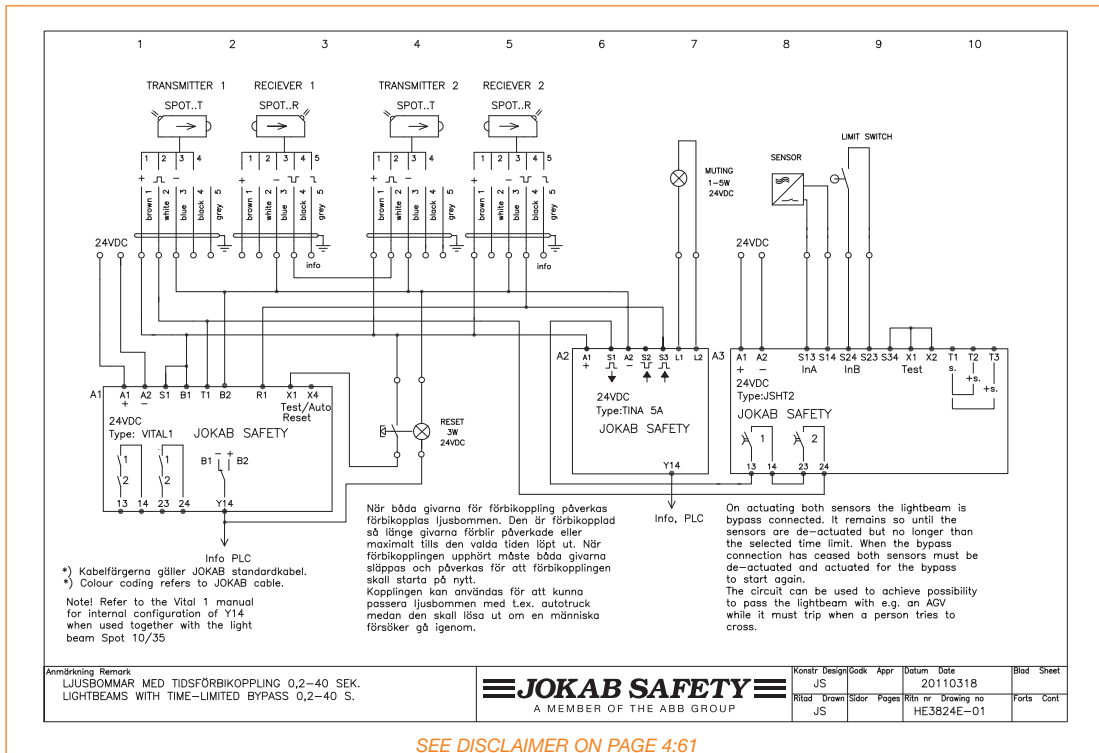



# HE3824F-01 Connection Example

## Eden and 2 Bypass Light Beams with Eden

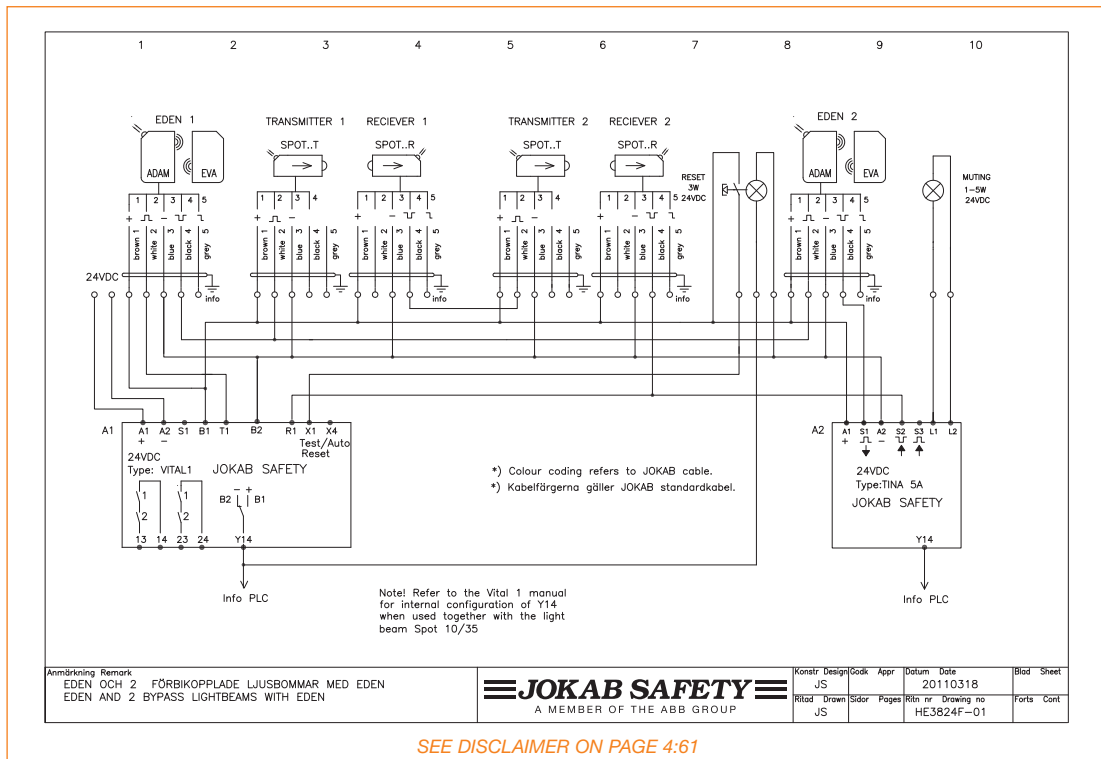

# HE3824G-01 Connection Example

## Eden and 2 Separately Bypassed Light Beams

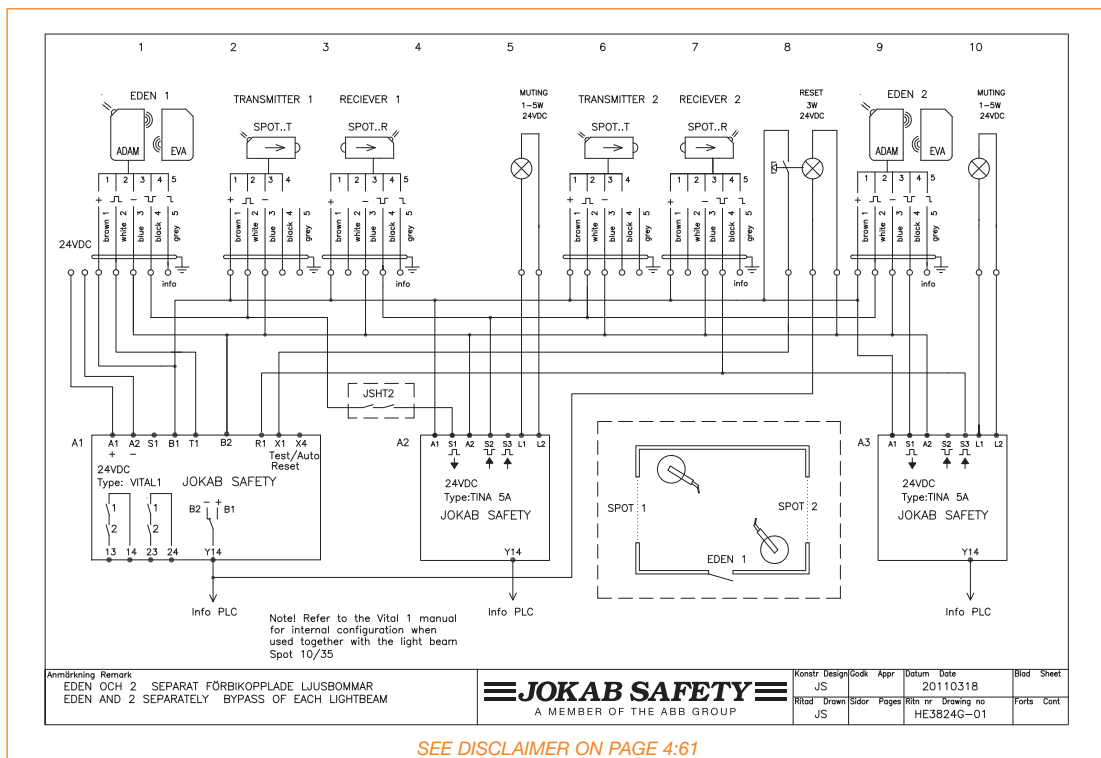

# HH3300A Connection Example

## Vital 1 with Different Types of Safety Devices and M12-3A

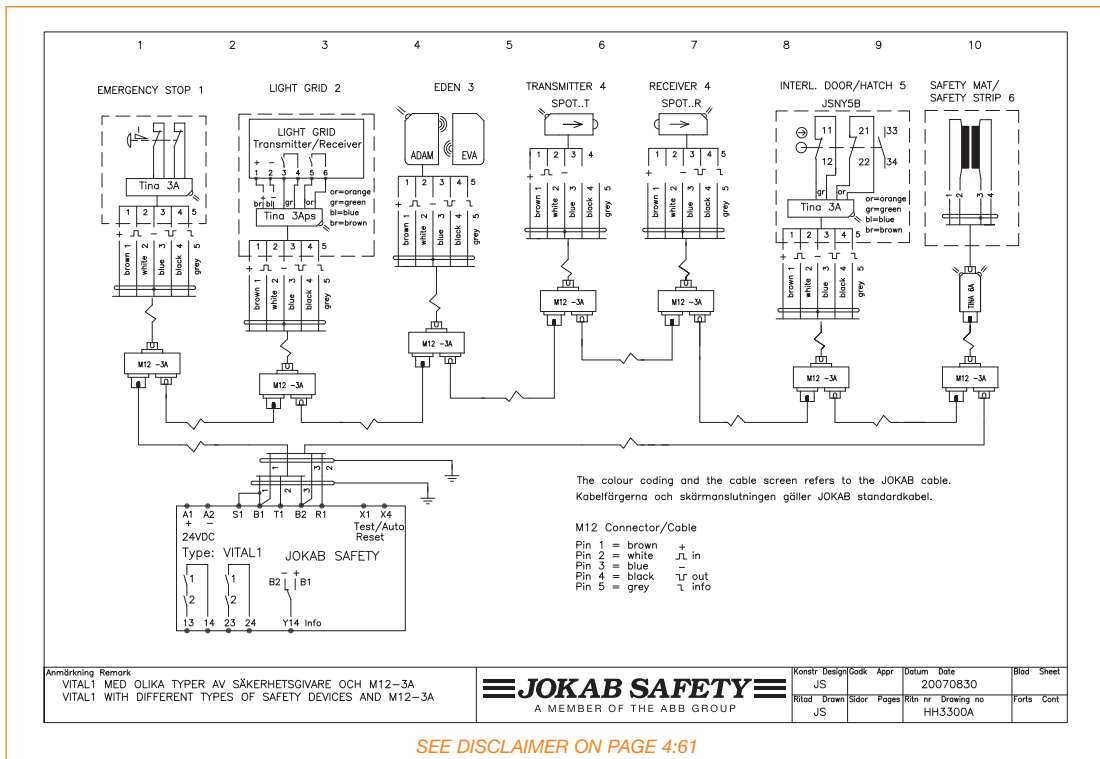

# HH3300D Connection Example

## Vital 1 with Tina 4A and Different Types of Safety Devices

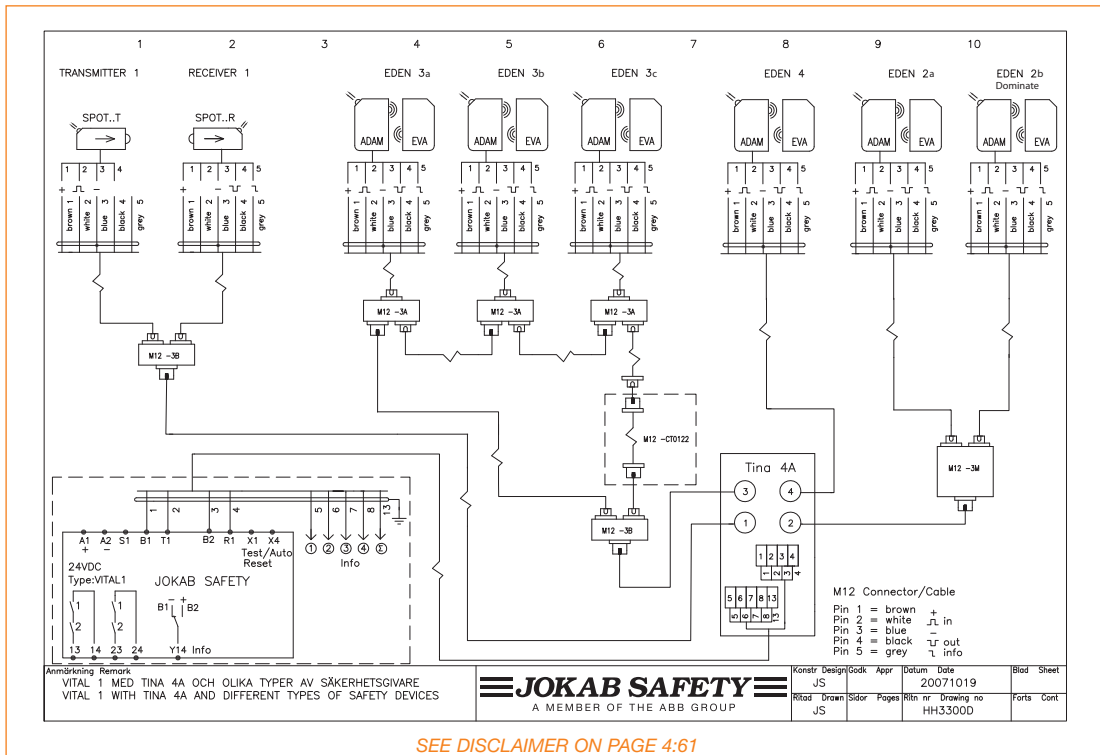

# HH3302D Connection Example

## Vital 1 with Tina 8A and Different Types of Safety Devices

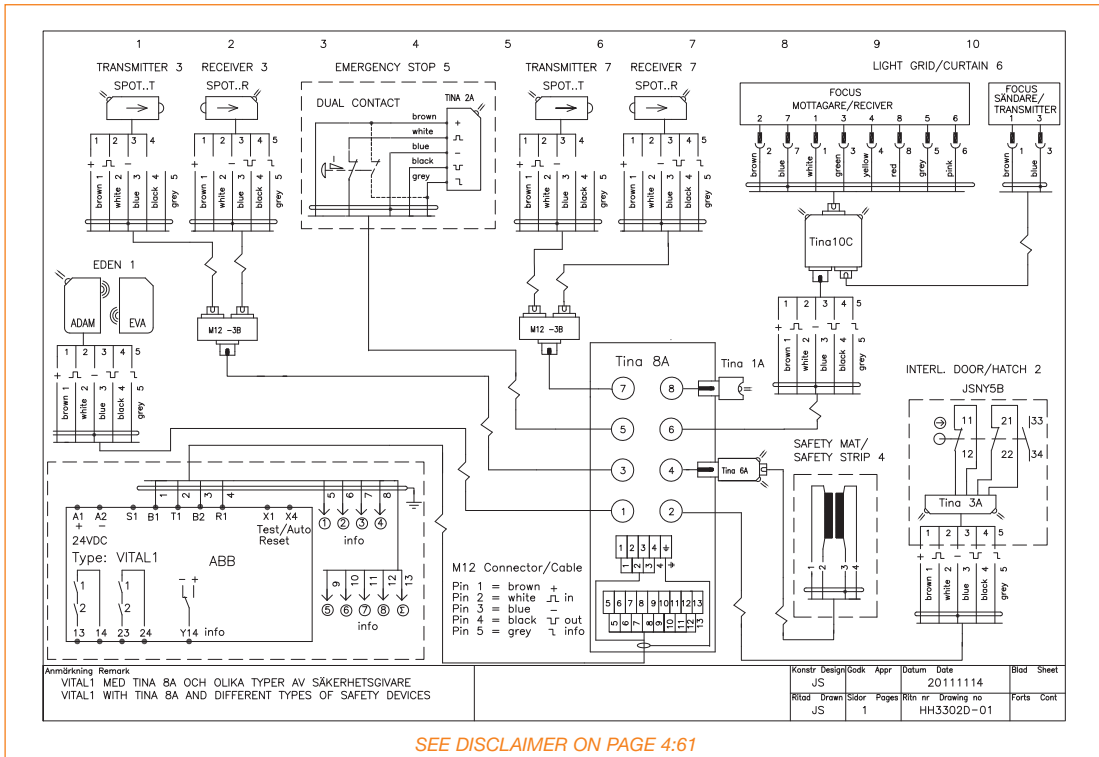

# HH3301E Connection Example

## Vital 1

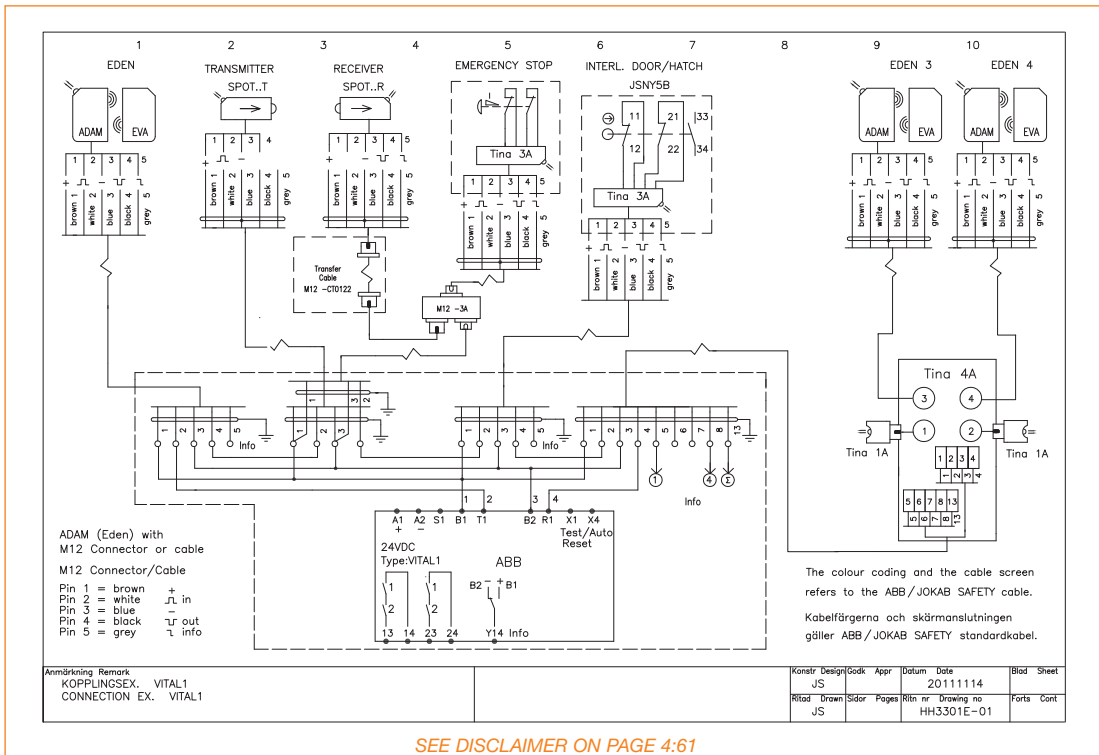

# HH3400A2 Connection Example

## Vital 1 Solutions

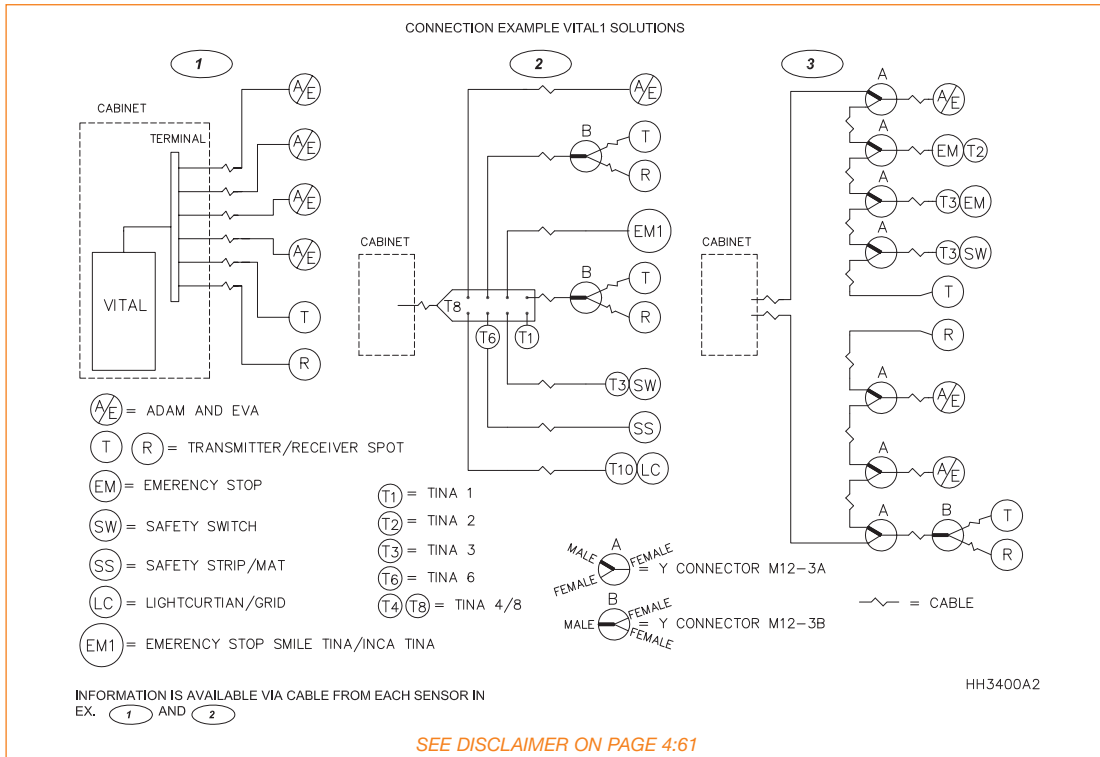

# HB0005A Connection Example

## Vital with Eden and Inca Emergency Stop, with Separate Reset

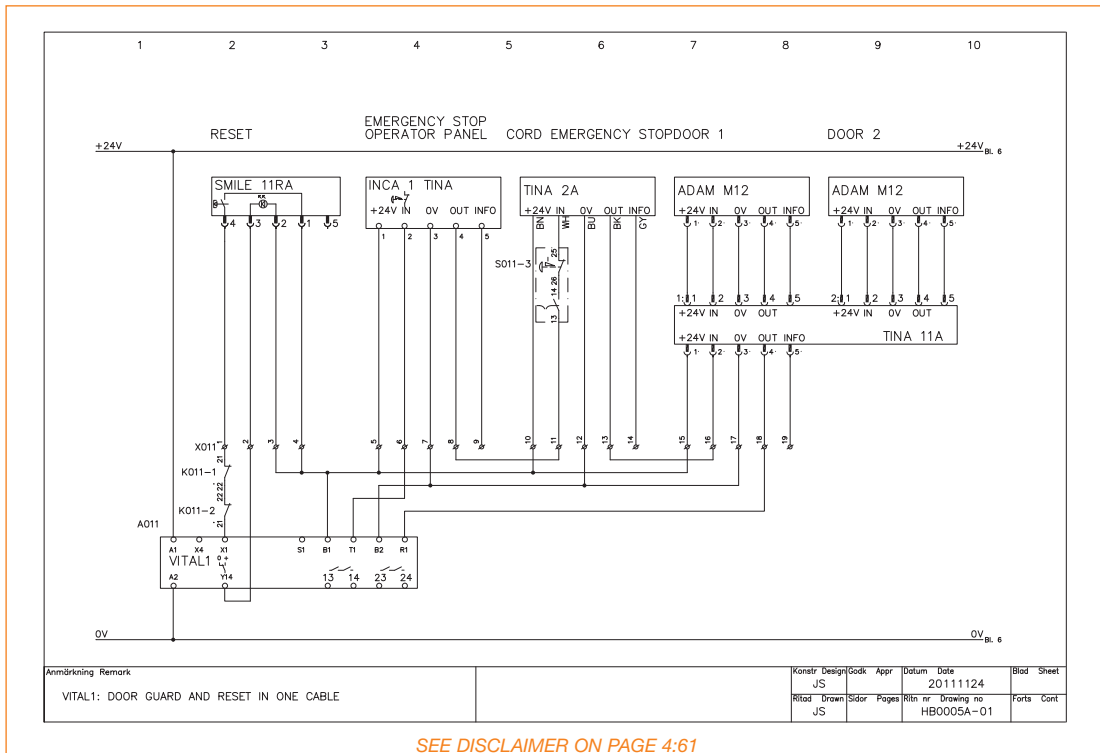

# HB0006A Connection Example

## Vital with 4 Eden Units + Reset via M12-3E and Tina 4A

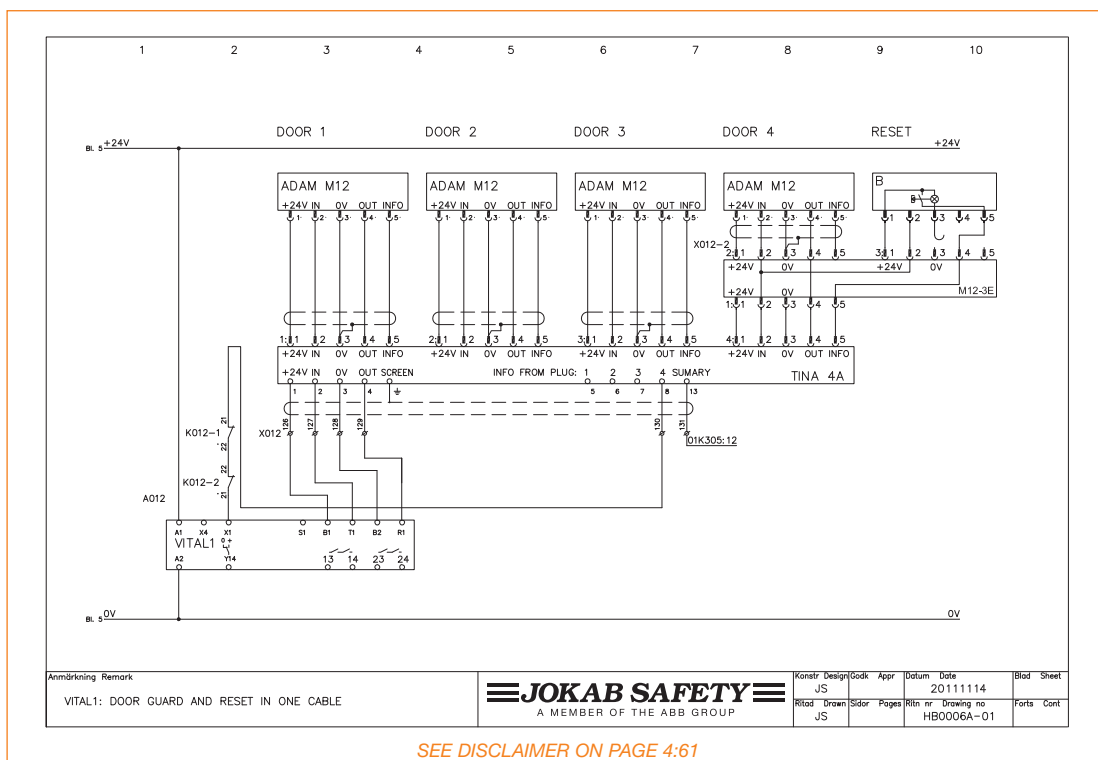

# HB0007A Connection Example

## Vital with Two Dalton Units via Tina 12A

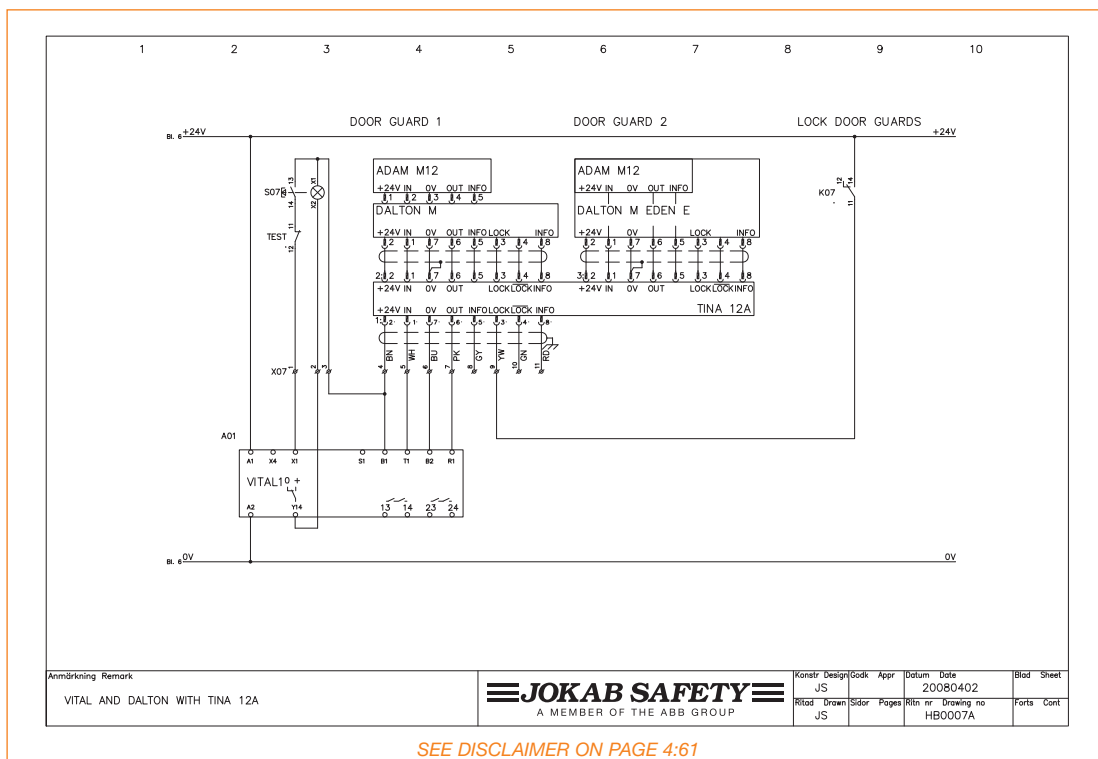

# HB0001A Connection Example

## Pluto with Smile Emergency Stop Unit + Reset via M12-3E and Adam via Tina 4A

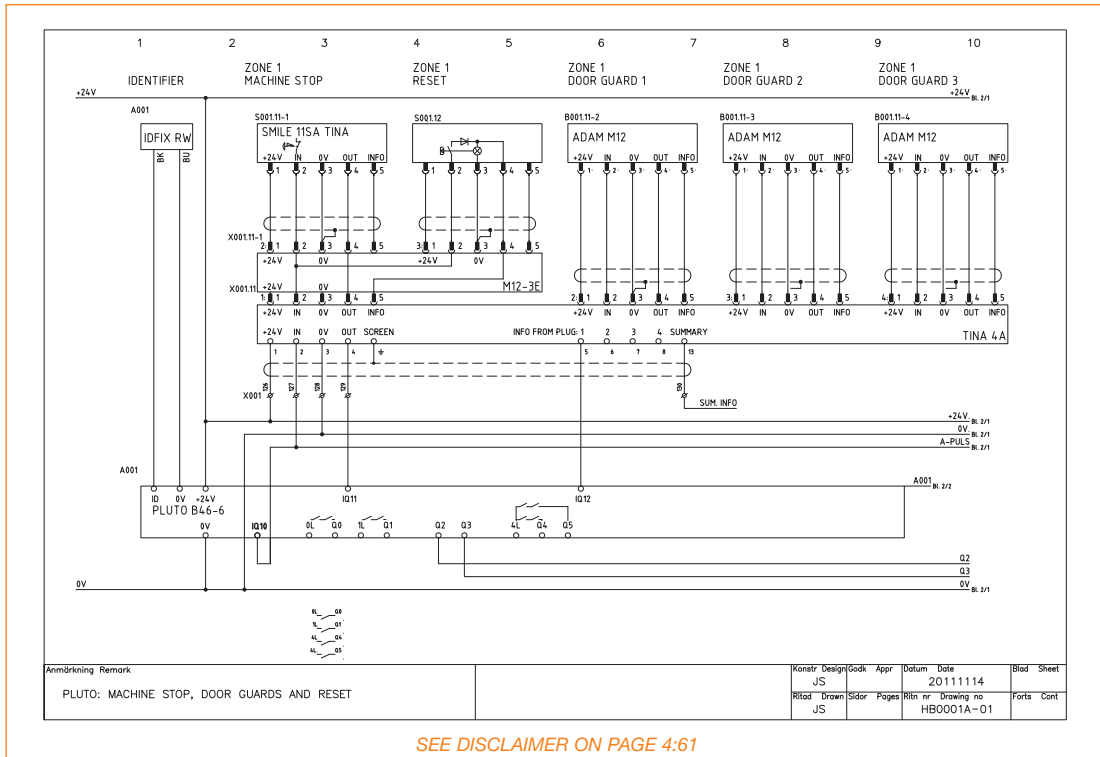

# HB0002A Connection Example

## Pluto with Five Eden Units, for Two Zones via M12-3E and Tina 4A

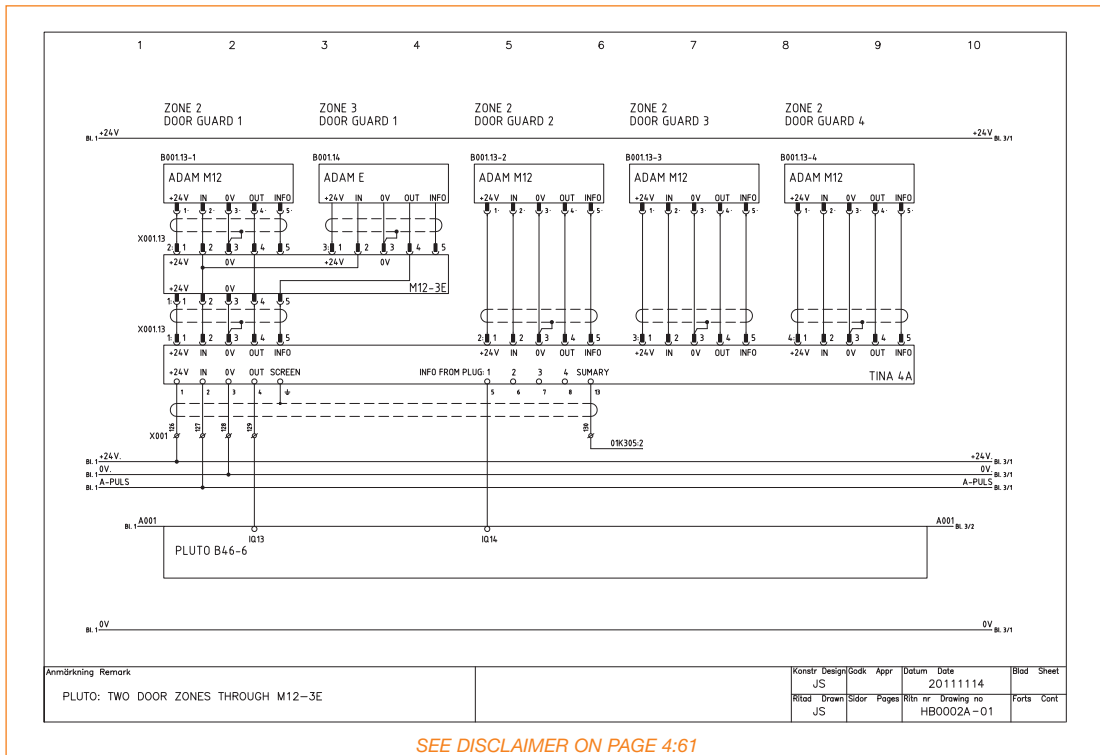

# HB0003A Connection Example

## Pluto with Smile and Inca Emergency Stop Units, via Tina 11A and Tina 4A

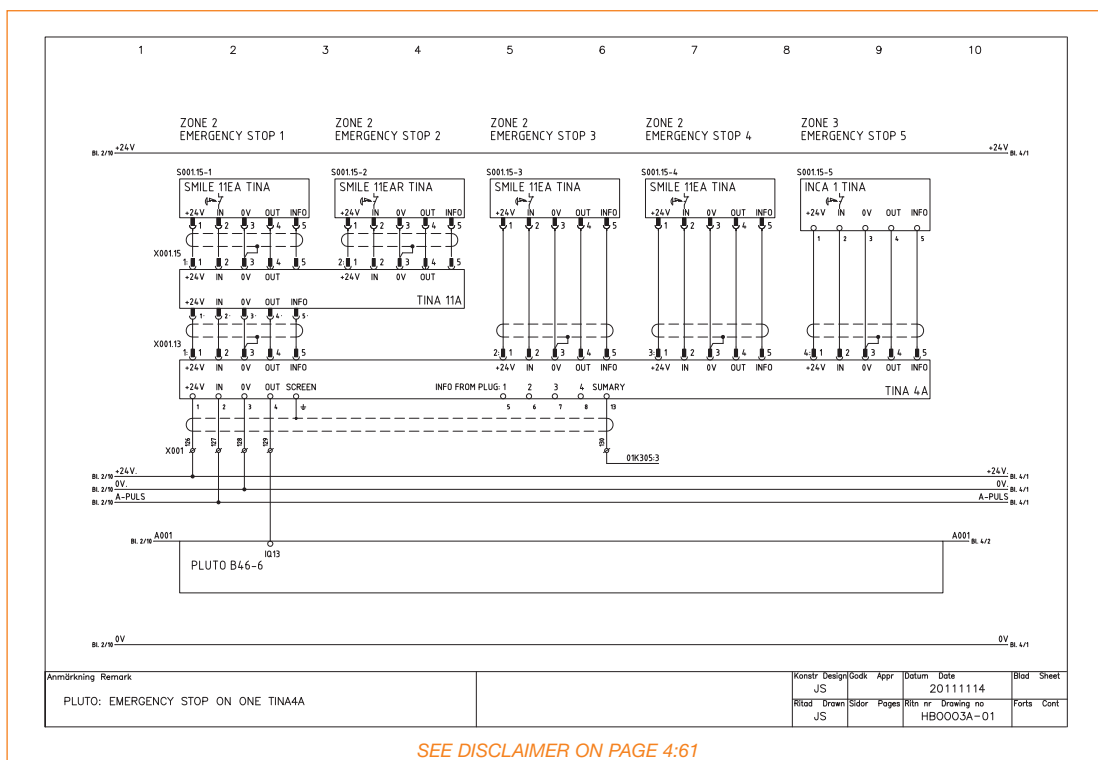

# HB0004A Connection Example

## Pluto with Different Zones for Eden + Reset and Two Eden units + via M12-3E

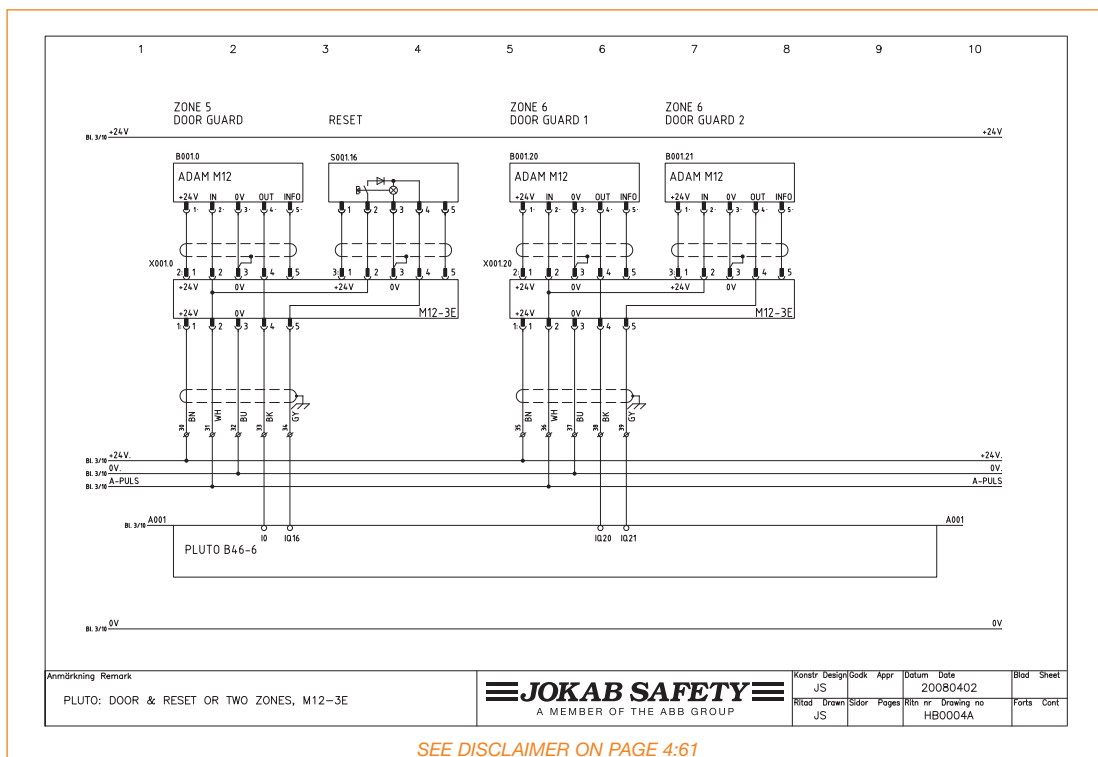

# HH3301D Connection Example

## Vital 1 and Tina 8A with Different Safety Device Types

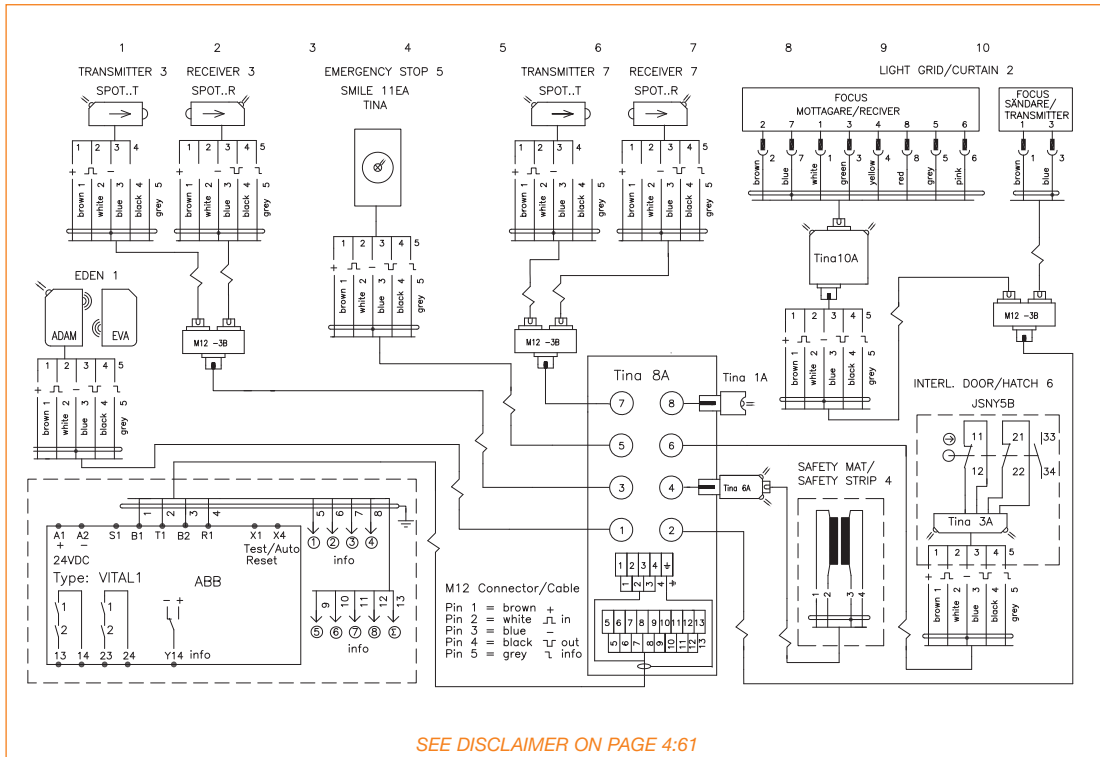



## Component List - Vital/Tina

Designation	Ordering Information	Description
Vital 1	2TLJ020052R1000	Safety controller with 2 safety outputs, uses unique dynamic signal technology, automatic or manual supervised reset, test input for monitoring of external positive guided relays/contactors, 5 LED indicators, 1 dual purpose information output, quick release terminal blocks, 22.5mm wide, 24VDC supply. Meets safety category 4, dynamic self test.
Vital 2	2TLJ020070R4300	Safety controller with 2 independant input circuits, up to 10 devices per circuit. 2 output groups. Group 2 can be set for time delay. LED indication and three different modes of operation. 24VDC supply. Meets safety category 4.
Vital 3	2TLJ020070R4400	Safety controller with 2 independant input circuits. Circuit 1 is for 2 channel devices, circuit 2 is for up to 10 dynamic devices. 2 output groups. Group 2 can be set for time delay. LED indication and three different modes of operation. 24VDC supply. Meets safety category 4.
Tina 1A	2TLJ020054R0000	Tina M12 dynamic port plug for Tina 4A/8A connection blocks. Must be used to fill empty ports not used on connection blocks. Multi-function status indicator LED.
Tina 2A	2TLJ020054R0100	Dynamic adapter for connecting potential free dry contact safety devices to the Vital 1 controller or Pluto Safety PLC. M20 thread connection for direct connection to the safety device or safety device enclosure, multi-function status indicator LED, integrated information output 24VDC - 10mA. Comes with plastic locking nut.
Tina 2B	2TLJ020054R1100	Dynamic adapter for connecting potential free dry contact safety devices to the Vital 1 controller or Pluto Safety PLC. Multi-function status indicator LED, integrated information output 24VDC - 10mA. For mounting inside of an enclosure.
Tina 3A	2TLJ020054R0200	Dynamic adapter with 5 pole M12 male quick disconnect for connecting potential free dry contact safety devices to the Vital 1 controller or Pluto Safety PLC. M20 thread connection for direct connection to the safety device or safety device enclosure, multi-function status indicator LEDs, integrated information output 24VDC - 10mA. Comes with plastic locking nut.
Tina 3Aps	2TLJ020054R1400	Dynamic adapter with 5 pole M12 male quick disconnect for connecting potential free dry contact safety devices to the Vital 1 controller or Pluto Safety PLC. M20 thread connection for direct connection to the safety device or safety device enclosure, multi-function status indicator LEDs, integrated information output 24VDC - 10mA, 24VDC and 0VDC power leads for powering up devices. Comes with plastic locking nut.
Tina 4A	2TLJ020054R0300	Dynamic 4 port connection block for connecting up to 4 safety devices with dynamic signal. Ports are 5 pole M12 female quick disconnects. Cable gland cover with internal terminal block for wiring 24VDC supply, dynamic signal input/output from Vital 1 controller or Pluto Safety PLC information outputs for each port, and summation output.

## Component List - Vital/Tina

Designation	Ordering Information	Description
Tina 5A	2TLJ020054R0400	Dynamic bypass connection module for bypassing safety devices with dynamic signal connected to Vital 1 controller. Can bypass one or multiple devices at once. 24VDC supply, LED indicators, information output Y14 rated at 24VDC - 10mA, quick disconnect terminal blocks, 22.5mm wide and monitoring of bypassing light (24VDC - 1 to 5W maximum).
Tina 6A	2TLJ020054R0600	Dynamic adapter with in-line 5 pole M12 male & female quick disconnects for connecting safety mats or strips with M12 connector to the Vital 1 controller or Pluto Safety PLC. Multi-function status indicator LEDs, integrated information output 24VDC - 10mA.
Tina 7A	2TLJ020054R0700	Dynamic adapter, din rail mount with quick disconnect for connecting potential free dry contact safety devices to the Vital 1 controller or Pluto Safety PLC. Multi-function status indicator LEDs, integrated information output 24VDC - 10mA.
Tina 8A	2TLJ020054R0500	Dynamic connection block with 8 ports for connecting up to 8 safety devices with dynamic signals. Ports are 5 pole M12 female quick disconnects. Cable gland cover with internal terminal block for wiring 24VDC supply, dynamic signal input/output from Vital 1 controller and information outputs for each port.
Tina 10A	2TLJ020054R1200	Dynamic adapter with 5 pole M12 male quick disconnect for connecting transistor output safety devices to the Vital 1 controller or Pluto Safety PLC. 8 pole M12 female quick disconnect for direct connection to the safety device or safety device enclosure, multi-function status indicator LEDs, integrated information output 24VDC - 10mA.
Tina 10B	2TLJ020054R1300	Dynamic adapter with 5 pole M12 male quick disconnect for connecting transistor output safety devices to the Vital 1 controller or Pluto Safety PLC. 5 pole M12 female quick disconnect for connecting a local reset and power off push button. 8 pole M12 female quick disconnect for direct connection to the safety device or safety device enclosure, multi-function status indicator LEDs, integrated information output 24VDC - 10mA.
Tina 10C	2TLJ020054R1600	Dynamic adapter with 5 pole M12 male quick disconnect for connecting transistor output safety devices to the Vital 1 controller or Pluto Safety PLC. 5 pole M12 female quick disconnect for connecting and powering the transmitter. 8 pole M12 female quick disconnect for direct connection to the safety device or safety device enclosure, multi-function status indicator LEDs, integrated information output 24VDC - 10mA.
Tina 11A	2TLJ020054R1700	Dynamic 2 port connection block for connecting up to 2 safety devices with dynamic signals. Ports are 5 pole M12 female quick disconnects. 5 pole M12 male quick disconnect for connecting the safety devices to the Vital 1 controller. Multi-function status indicator LEDs, integrated information output 24VDC - 10mA.
Tina 12A	2TLJ020054R1800	Dynamic 2 port connection block for connecting up to 2 safety devices with dynamic signals and locking inputs. Ports are 8 pole M12 female quick disconnects. 8 pole M12 male quick disconnect for connecting the safety devices to the Vital 1 controller. Multi-function status indicator LEDs, integrated information output 24VDC - 10mA.

## Component List - Vital/Tina

Designation	Ordering Information	Description
M12-3A	2TLA020055R0000	M12 Y connector for series connection for Vital/Pluto safety devices such as Eden Sensors, Smile E-Stops, Inca E-Stops, Spot Single Beams, and Tina Dynamic Adapters. 5 pole M12 female quick disconnect connector for connection of the safety device. 5 pole M12 male quick disconnect for connecting 24VDC, 0VDC and the dynamic transmit signal to the field devices. 5 pole M12 female quick disconnect connector for either the continuation of the circuit or the return of the dynamic receive signal to the Vital 1/Pluto controller.
M12-3B	2TLA020055R0100	M12 Y connector for the parallel connection of 2 Vital/Pluto safety devices such as Eden Sensors, Spot Signal Beams and Tina Dynamic Adapters. Two 5 pole M12 female quick disconnect connectors for connection of the safety devices. 5 pole M12 male quick disconnect for connection to the Vital 1/Pluto controller.
M12-3D	2TLA020055R0300	M12 Y connector parallel Connection. 1 M12 8 pole female connector for connection of the Focus Receiver, 1 M12 5 Pole female connector for connection of the Focus Transmitter and 1 M12 8 pole male connector for panel connection.
M12-3E	2TLA020055R0200	M12 Y connector for the connection of 2 different safety or non-safety circuits in one cable. 5 pole M12 female quick disconnect connector for connection of the first circuit. 5 pole M12 female quick disconnect connector for connection of the second circuit. 5 pole M12 male quick disconnect for connection to IQs on the Pluto controller.
M12-C61	2TLA020056R0000	Cable single ended 6 meter black PVC jacket with straight 5 pole M12 female molded connector, 22AWG conductors, overall braid shield.
M12-C101	2TLA020056R1000	Cable single ended 10 meter black PVC jacket with straight 5 pole M12 female molded connector, 22AWG conductors, overall braid shield.
M12-C201	2TLA020056R1400	Cable single ended 20 meter black PVC jacket with straight 5 pole M12 female molded connector, 22AWG conductors, overall braid shield.
M12-C61V	2TLA020056R0100	Cable single ended 6 meter black PVC jacket with angled 5 pole M12 female molded connector, 22AWG conductors, overall braid shield.
M12-C101V	2TLA020056R1100	Cable single ended 10 meter black PVC jacket with angled 5 pole M12 female molded connector, 22AWG conductors, overall braid shield.
M12-C62	2TLA020056R0200	Cable single ended 6 meter black PVC jacket with straight 5 pole M12 male molded connector, 22AWG conductors, overall braid shield.*
M12-C102	2TLA020056R1200	Cable single ended 10 meter black PVC jacket with straight 5 pole M12 male molded connector, 22AWG conductors, overall braid shield.*





\*Screen connected to pin 7 (0VDC) on male connector.

## Component List - Vital/Tina

Designation	Ordering Information	Description
M12-C112	2TLA020056R2000	Extension cable 1 meter, black PVC jacket with straight 5 pole M12 male/female connectors, 22AWG conductors, overall braid shield.*
M12-C312	2TLA020056R2100	Extension cable 3 meters, black PVC jacket with straight 5 pole M12 male/female connectors, 22AWG conductors, overall braid shield.*
M12-C612	2TLA020056R2200	Extension cable 6 meters, black PVC jacket with straight 5 pole M12 male/female connectors, 22AWG conductors, overall braid shield.*
M12-C1012	2TLA020056R2300	Extension cable 10 meters, black PVC jacket with straight 5 pole M12 male/female connectors, 22AWG conductors, overall braid shield.*
M12-C2012	2TLA020056R2400	Extension cable 20 meters, black PVC jacket with straight 5 pole M12 male/female connectors, 22AWG conductors, overall braid shield.*
M12-C63	2TLA020056R3000	Cable single ended 6 meters black PVC jacket with straight 8 pole M12 female molded connector, 22AWG conductors, overall braid shield.
M12-C103	2TLA020056R4000	Cable single ended 10 meters black PVC jacket with straight 8 pole M12 female molded connector, 22AWG conductors, overall braid shield.
M12-C203	2TLA020056R4100	Cable single ended 20 meters black PVC jacket with straight 8 pole M12 female molded connector, 22AWG conductors, overall braid shield.
M12-C134	2TLA020056R5000	Extension cable 1 meter, black PVC jacket with straight 8 pole M12 male/female connectors, 22AWG conductors, overall braid shield.*
M12-C334	2TLA020056R5100	Extension cable 3 meter, black PVC jacket with straight 8 pole M12 male/female connectors, 22AWG conductors, overall braid shield.*
M12-CT0122	2TLA020060R0000	Transfer cable 10cm, black PVC jacket with 2 straight 5 pole M12 male connectors, 22AWG conductors, overall braid shield. Pin 2 transfers to pin 4 for connection to M12-3A Y connector.
M12-CT0214	2TLA020060R0100	Extension cable 20cm, black PVC jacket with straight 5 pole M12 female, 8 pole M12 male connectors, 22AWG conductors, overall braid shield.
M12-CT0232	2TLA020060R0200	Extension cable 20cm, black PVC jacket with straight 5 pole M12 male, 8 pole M12 female connectors, 22AWG conductors, overall braid shield.
M12-CT0134F	2TLA020060R0300	Extension cable 1m, black PVC jacket with straight 8 pole M12 male/female connectors, 22AWG conductors, overall braid shield. Transfer pins.
C5	2TLA020057R0000	Cable 5 conductors, 22AWG, black PVC jacket cable with overall braid shield. Per meter. OD - 5.5mm +/- .15mm.
C8	2TLA020057R1000	Cable 8 conductors, 22AWG, black PVC jacket cable with overall braid shield. Per meter. OD - 6.3mm +/- .15mm.
C9	2TLA020057R1500	Cable 7 conductors at 20AWG and 2 conductors at 18AWG, aluminum shield, drain. Per meter. OD - 8mm. For use with Tina 4A.
C13	2TLA020057R2000	Cable 11 conductors at 20AWG and 2 conductors at 18AWG, aluminum shield, drain. Per meter. OD - 9mm. For use with Tina 8A.

\*Screen connected to pin 7 (0VDC) on male connector.

## Component List - Vital/Tina

Designation		Ordering Information	Description
M12-C01		2TLA020055R1000	5 pole M12 female field retro-fittable connector with screw terminals for connecting wires. Cable diameter range 2.5 - 6.5 mm.
M12-C02		2TLA020055R1100	5 pole M12 male field retro-fittable connector with screw terminals for connecting wires. Cable diameter range 2.5 - 6.5 mm.
M12-C03		2TLA020055R1600	8 pole M12 female field retro-fittable connector with screw terminals for connecting wires. Cable diameter range 2.5 - 6.5 mm.
M12-C04		2TLA020055R1700	8 pole M12 male field retro-fittable connector with screw terminals for connecting wires. Cable diameter range 2.5 - 6.5 mm.

This document and any attachments may include suggested specifications, drawings, schematics and similar materials from ABB Inc. Use of such information and/or documentation by the recipient is subject to and conditioned upon your acceptance of the terms of the General Document Disclaimer which can be found at [www.jokabsafety.com](http://www.jokabsafety.com). Your acceptance of the terms of such General Document Disclaimer is conclusively presumed unless you notify ABB in writing of your disagreement with the terms of such Disclaimer immediately upon receipt of this document and you return to ABB all specifications, drawings, schematics and similar materials provided to you by ABB.

# Notes



# Safety Relays

Meet existing safety standards!  
 Supervise safety devices!  
 Safe stops and reliable restarts!

*Our universal safety relays offer various input options for use with many different safety devices and risk levels*



Why should I use Safety Relays?..... 5:2

The Smallest and Most Flexible Safety Relays on the Market ..... 5:3

Creating a Control Reliable Safety System ..... 5:4

Choice of Safety Category ..... 5:6

Safety Relays Summary ..... 5:6

Safety Relays - RT Series

- RT6..... 5:8
- RT7..... 5:12
- RT9..... 5:16
- JSBRT11 ..... 5:20

Safety Relays - JSB Series

- JSBR4 ..... 5:22
- JSBT4..... 5:24
- BT50/BT50T ..... 5:26
- BT51/BT51T ..... 5:28
- JSBT5(T)..... 5:30

Safety Timers

- JSHT1 A/B ..... 5:32
- JSHT2 A/B/C ..... 5:34

Expansion Relays

- E1T ..... 5:36
- JSR1T..... 5:38
- JSR2A ..... 5:40
- JSR3T..... 5:42

Connection Examples ..... 5:44

Component List and Ordering Information ..... 5:62

# Why should I use Safety Relays?

## ...to meet existing safety standards!

*“A fault in the hardware or the software of the control system must not lead to hazardous situations.”* This is the requirement in the EU’s Machinery Directive 2006/42/EG under the heading 1.2.1 “Safety and reliability of control systems”. The directive implies that no person should be put at risk if for example, a relay sticks or if a transistor or two electrical conductors short-circuit.

A safety relay will fulfill these requirements. A safety relay has, for example, inputs that are checked for short-circuits and dual redundant circuits that are checked at each operation. This can be compared to the dual brake circuits in a car. If one of the circuits is faulty the other will stop the car. In a safety relay there is an additional function which only allows a machine to start if both circuits are ok.

The safety standard describes various safety categories depending on the level of risk and application. One single universal relay with selectable safety categories solves this.

## ...for safe stops and reliable restarts!



### Dual stop signals when the gate is opened...

Entering or putting a hand or limb into a hazardous area, must cause all machines that can cause a personal injury to stop safely. Many serious accidents occur when machinery is believed to have stopped but is in fact only pausing in its program sequence. The safety relay monitors the gate interlock switch, the cables and gives dual stop signals.



### Supervised reset when there can be a person within the risk area...

Make sure that nobody is within the restricted area when activating the reset button. A supervised reset button must be pressed and released before a reset can occur. Many serious accidents have been caused by an unintentional and unsupervised reset.



### Timed reset when you cannot see the entire risk area...

Sometimes a double reset function is necessary to make sure that no one is left behind in the risk area. First, after ensuring no other person is inside the hazardous area, the pre-reset button must be activated, followed by the reset button outside the risk area within an acceptable time period e.g. 10 seconds. A safety timer and a safety relay can provide this function.



### Automatic reset for small hatches...

Where body entry is not possible through a hatch, the safety circuit can be automatically reset.

The safety relays are reset immediately when the hatch interlock switch contacts are closed.

## ...to supervise safety devices!



Light Beams



Light Curtains



3-Position Devices



2-Hand Devices



Safety Interlock Switches



Emergency Stop Buttons



Safety Strips and Bumpers



Safety Guard Mats



# The Smallest and Most Flexible Safety Relays on the Market!

We have the most flexible safety relays on the market. Our first universal relay was developed nearly 20 years ago. Today the flexibility is even greater and the size has been reduced by 85%.

A universal relay is a safety relay with various input options for various safety devices and risk levels. Internally, the safety relay is of the highest safety level (category 4 according to EN 954-1/EN ISO 13849-1). A machine supplier can therefore, with one single safety relay, select the input configuration that best suits his customer's safety requirements. In addition, our safety relays have detachable connector blocks for ease of replacement and testing.

As our universal relay incorporates all input options, it is compatible with all our previous safety relays as well as with other manufacturers products.

Is a universal relay expensive? No, our latest patented construction is extremely simple and the number of major components is less compared to our previous universal relays. This means that our safety relays are even more reliable and economical than before.

We also have gained a great deal of experience from creating safety solutions for our own systems. It would be our pleasure to share these experiences with you! Please do not hesitate to contact us if you should require any other safety solutions.

*Inputs for various safety devices*

*Input for manual or automatic resetting*

**RT7: The most flexible Safety Relay on the market!**

*Detachable connector blocks*

*Outputs for program stop, gate opened or closed and reset indication*

*Safety outputs for immediate and delayed stops at optional times*

**Some of the advantages with JOKAB SAFETY's Safety Relays...**

- Universal relays
- Excellent reliability
- Approved in Europe, USA, Canada
- Supervised reset
- Time reset
- Small and compact
- Detachable connector blocks
- Low power consumption
- Permits the use of long runs of cables
- Functions set by external hardwired links
- LED indication and outputs for indication
- Powerful switching capacity

## Creating a Control Reliable Safety System

Where required by the appropriate ANSI standard (example clause 4.5.4 of RIA 15.06.1999), the importance of using safety relays to achieve control reliable circuits can be explained. Control Reliable Systems

must be designed “such that a single component failure within the system does not prevent the stopping action from taking place but will prevent successive system cycle until that failure has been corrected.”

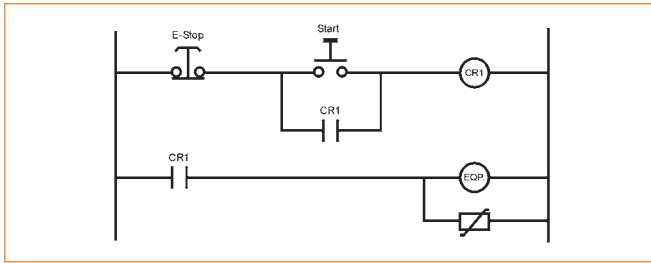

### Ladder Diagram of a Common Emergency Stop Circuit

In this typical emergency stop circuit the weakest link is relay CR1. The contacts of CR1 can weld closed or, since this relay is spring applied, it can fail mechanically. If this failure occurred, energy to the load would continue resulting in an UNSAFE CONDITION that would cause machine damage and/or personnel injury. ANSI standards and OSHA regulations demand prevention of such a condition.

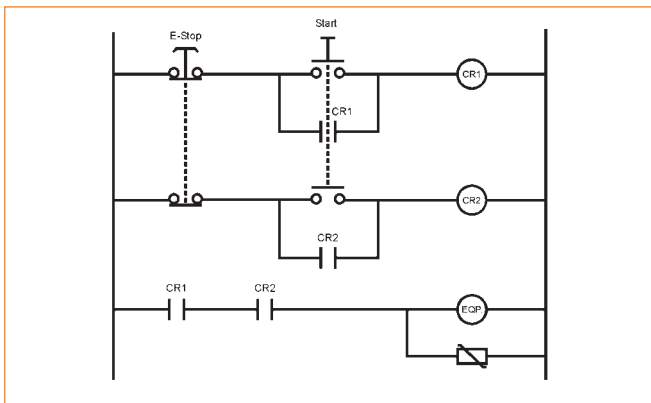

### Ladder Diagram using two Force-Guided Relays to Achieve Redundancy

According to the definition of control reliability we need to guard against failure of CR1. It is one source for a single component failure. Redundancy is not sufficient. If one of the two relays fail you are back to square one — with redundancy lost, the second relay could fail on a subsequent machine cycle.

We must monitor the condition of the redundant relays. Force or positive guided relays provide the best solution to accomplish monitoring.

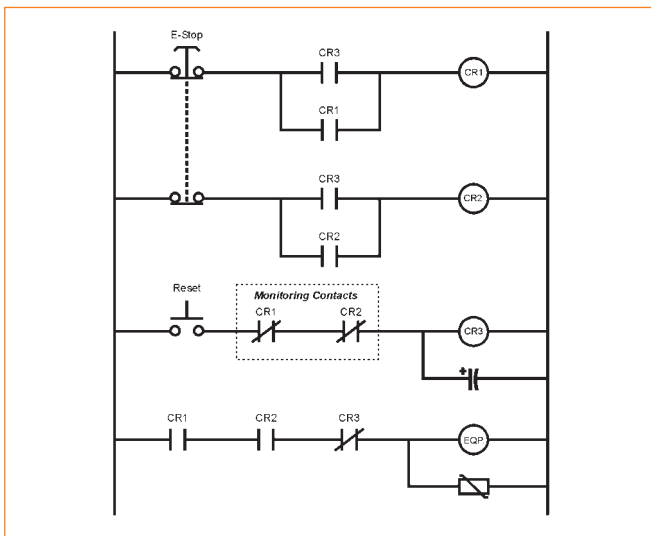

### Ladder Diagram of a Circuit using three Force-Guided Relays

This circuit is approaching control reliable. Using positive guided relays offers redundancy and cross-monitoring, but does not monitor for short circuits or reset problems.

*Note: Safety Category only refers to the safety relay configuration, input devices, output devices and wiring must be considered for a safety category of the system.*

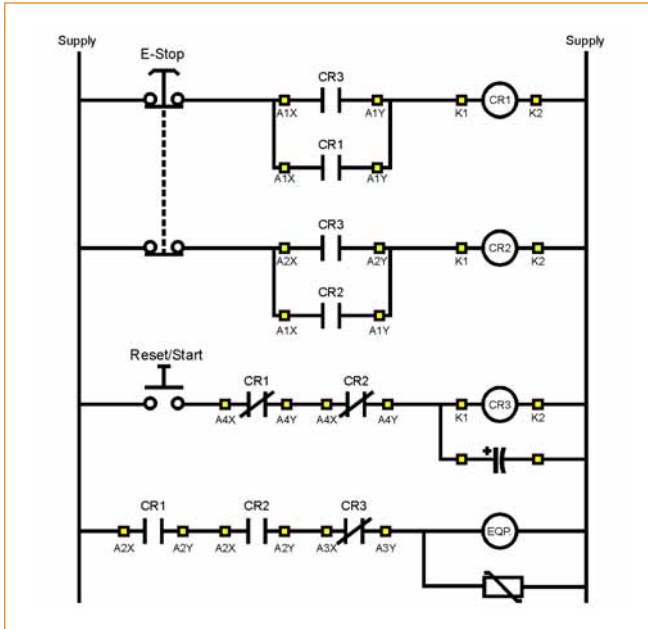

## Ladder Diagram using three Force-Guided Relays

### Advantages

- Has redundancy and cross-monitoring

### Disadvantages (in comparison to the Jokab Safety Relay)

- No safety approvals
- 38 wiring points
- High chance of wiring errors
- Installation is labor intensive
- More costly
- Larger in overall size (panel space)
- Easy to tamper with and bypass connections
- No short circuit protection on the inputs
- Reset is not monitored
- Difficult to troubleshoot
- The more contacts needed, the more complicated the circuit.

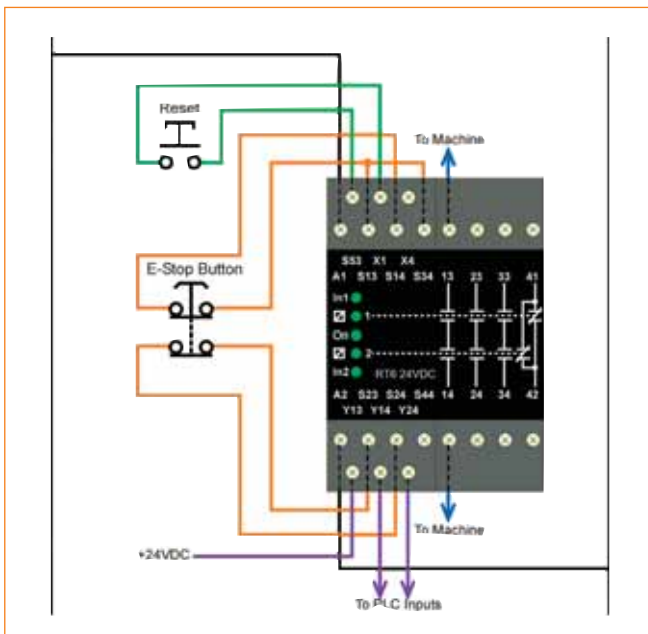

## Wiring Diagram using a RT6 Jokab Safety Relay connected in Input Configuration Mode 4 to Achieve Control Reliability Electrically

### Advantages (in comparison to the 3 Force-Guided Relays Circuit)

- Control reliable electrically
- Has redundancy and cross-monitoring
- 4 input configuration modes which are hardwire selectable (selectable category of safety)
- 2 reset configuration modes which are hardwire selectable
- Manual supervised reset mode monitors the button and wiring against failure
- Input configuration modes 3 and 4 monitor all input devices and wiring against failure
- Monitors external positive or force-guided contactors/relays
- Universal (multi-purpose)
- Retrofits easily into existing systems
- 5 LED indicators: Power On, Input 1, Input 2, Output K1 and Output K2
- 3 NO safety outputs, 1 NC monitoring output
- 2 transistor outputs for input status and output status
- Available in a variety of source voltages
- Terminal strips are removable for easy change
- 17 wiring points
- Cost effective
- Compact in size (45 mm in width)
- Several safety approvals

*Note: Safety Category only refers to the safety relay configuration, input devices, output devices and wiring must be considered for a safety category of the system.*

# Safety Relays Summary

## Which Safety Relay should you choose?

First of all, we recommend the selection of one of our latest universal relays in the RT-series. These are both practical and cost effective. To facilitate the choice of safety relay or combinations of safety relays, please see:

- the table below dividing the safety relays into application fields
- the table on the opposite page showing possible input and output options

- the relevant data sheet giving comprehensive information about each specific safety relay
- the circuit diagram for various applications are located in "Connection Examples" beginning on page 5:44

*Note: All earlier type of relays that can now be replaced by those in this manual are still kept as stock items and can be supplied upon request.*

## Application Fields

	Safety Relays								Safety Timers		Expansion Relays			
	RT6	RT7	RT9	JSBRT11	JSBR4	JSBT4	JSBT5T/BT50T/BT51T	JSBT5/BT50/BT51	JSH11A/B	JSH2A/B/C	E1T	JSR1T	JSR2A	JSR3T
Interlocking Switch/Gate/Hatch	•	•	•	•	•	•	•	•						
Light Curtains	•	•	•	•										
Light Beams	•	•	•	•										
Safety Mats	•	•	•		•	•								
Contact Strips	•	•	•		•	•								
Two-Hand Control Device					•									
Emergency Stop	•	•	•	•	•	•	•	•						
Hold to Run/Enabling Device	•	•	•	•	•	•				•				
Foot Control Device	•	•	•	•	•	•				•				
Area Supervision	•	•	•	•	•	•								
Time Resetting									•					
Time Bypassing									•	•				
Inching										•				
Output Expansion	•	•	•	•		•	•	•			•	•	•	
Delayed Output		•					•				•	•		•

## Input Alternatives

Single-Channel,  
1 NO from +24V  
Safety Category 1



The input must be closed before the outputs can be activated. A stop signal is given when the input is opened.

Two-channel,  
2 NO from +24V  
Safety Category 3

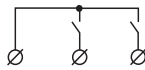

Both the inputs must be closed before the outputs can be activated. A stop signal is given if one or both of the inputs are opened. Both the inputs must be opened and reclosed before the outputs can be reactivated. A short-circuit between the inputs is not monitored by the safety relay. Category 4 can only be achieved if a safety device with short circuit monitored outputs is connected.

Two-Channel,  
1 NO & 1 NC  
from +24 V  
Safety Category 4

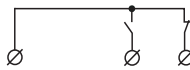

One input must be closed and one must be opened before the outputs can be activated. A stop signal is given if one or both of the inputs change position or if the inputs short-circuit. Both inputs must be put into their initial position before the outputs can be reactivated.

Two-Channel,  
1 NO from 0 V &  
1 NO from +24 V  
Safety Category 4

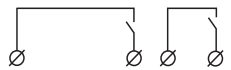

Both the inputs must be closed before the outputs can be activated. A stop signal is given if one or both of the inputs are opened. Both the inputs must be opened and reclosed before the outputs can be reactivated. Stop signal is given if there is a short-circuit between the inputs.

## Technical Data

- \* indicates the possibility of selecting delayed outputs
- indicates one relay contact per output (other relays having two contacts per output)
- ‡ delayed
- category 4 depending on connection (when used as expansion relay with Pluto Safety PLC, then category 4)
- † fixed 0.5 s delay

	Safety Relays											Safety Timers		Expansion Relays			
	RT6	RT7	RT9	JSBRT11	JSBR4	JSBT4	JSBT5T	BT50T	BT51T	BT50	BT51	JSHT1A/B	JSHT2A/B/C	E1T	JSR1T	JSR2A	JSR3T
<b>Safety Category</b>	1-4	1-4	1-4	1-4	4	4	1-4 <sup>○</sup>	1-4 <sup>○</sup>	1-4 <sup>○</sup>	1-4 <sup>○</sup>	1-4 <sup>○</sup>	1-4	1-4	1-4	1-4	1-4	1-4
<b>Safety Input</b>																	
Single-Channel, 1 NO from +24 V	●	●	●	●			●	●	●	●	●	●	●	●	●	●	●
Two-Channel, 2 NO from +24 V	●	●	●	●													
Two-Channel, 1 NO & 1 NC from +24 V	●	●	●	●													
Two-Channel, 1 NO from 0 V & 1 NO from + 24 V	●	●	●	●	●	●						●	●	●	●	●	●
Contact Strips/Safety Mats	●	●	●		●	●											
<b>Reset &amp; Test Input</b>																	
Monitored Manual	●	●	●	●	●												
Automatic/Unmonitored Manual	●	●	●	●		●	●	●	●	●	●	●	●				
Testing of Contactors, Relays, Valves, etc.	●	●	●	●	●	●	●	●	●	●	●	●	●				
<b>Output</b>																	
NO	3	2	2	7	3	3					3	4			4*	4*	4
NO Delayed		2					3†	3	4						4*	4*	2□
NO Impulse Outputs													2□	2□			
NC	1	1		2	1	1					1				1*	1	
NC Delayed							1†	1							1*		
Information Output	2	3	1					1	1								
<b>Switching Capacity (Resistive Load)</b>																	
6A/250VAC/1500VA/150W	4	3	2	9	4	4	4	4‡	4‡	4	4			4	5		
4A/250VAC/1000VA/100W												2□	2□				2□
6A/250VAC/1380VA/138W		2‡															
10A/250VAC/1840VA/192W																5	
<b>Width (mm)</b>	45	45	22.5	100	45	45	22.5	22.5	22.5	22.5	22.5	45	45	22.5	45	45	22.5
<b>Supply Voltage</b>																	
12VDC							●										
24VDC	●	●	●	●	●	●	●	●	●	●	●	●	●	●	●	●	●
24VAC	●	●		●	●	●	●					●	●			●	●
48VAC	●	●		●	●	●						●	●			●	
115VAC	●	●		●	●	●						●	●			●	
230VAC	●	●		●	●	●						●	●			●	

Contact strips/  
Safety Mats  
Category 3,  
up to PL d

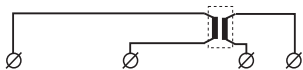

For an unpressurized mat/strip, both the relay inputs must be closed for the outputs to be activated. In the case of an activated mat/strip and short-circuit input channels, the relay will be de-energized. Current limitation prevents the safety relay from being overloaded when the channels short-circuit.

Monitored  
Manual Reset



A monitored reset means that the safety relay will not be reset if the reset button gets jammed when pressed in or if the input short-circuits. In order for the resetting to be complete, the input must be closed and opened before the outputs can close.

Automatic/  
Unmonitored  
Manual  
Reset



Automatic reset means that the outputs are closed immediately when both the input conditions are satisfied and the test input is closed.

Testing of  
Contactors,  
Relays  
and Valves

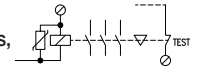

Can be carried out with both automatic and manual reset.

**Note:** If serial contacts are connected to the input, the Safety Category is made lower for two-channel connections. Safety Category only refers to the safety relay configuration. Input devices, output devices and wiring must be considered for a safety category of the system.

# RT6 Safety Relay

## Would you like a single safety relay for all your safety applications?

Then choose the RT6 universal relay to supervise both your safety devices and the internal safety of your machinery. In addition you can select the safety level required for each installation. All this is possible because the RT6 has the most versatile input option arrangement available on the market. Many other relays can therefore be replaced by the RT6.

The relay also comes with other options such as manual or automatic reset. Manual supervised reset can be used for gates and other safety devices that can be passed through. Automatic reset can be used for small hatches, if deemed acceptable from a risk assessment.

The RT6 also has information outputs that follow the inputs and outputs of the relay. These outputs will for example indicate if a gate is open or closed and if the safety relay needs to be reset.

The RT6 is designed with a minimum amount of components thus keeping both production costs and component acquisitions to a minimum.

Choose the RT6 to simplify your safety circuits and reduce your costs.

### Connection Examples

For examples of how our safety relays can solve various safety problems, see “Connection Examples” beginning on page 5:44.



### Applications

- Emergency Stops
- Light Curtains
- Three Position Devices
- Interlocked Gates/Hatches
- Magnetic Switches
- Light Beams
- Safety Mats
- Contact Strips
- Foot-Operated Switches

### Features

- Five input options
- Single or dual channel input
- Manual supervised or automatic reset
- Test input for supervision of external contactors
- Width 45 mm
- LED indication of supply, inputs, outputs, short-circuit and low voltage level
- 3 NO/1 NC relay outputs
- Two voltage free transistor information outputs
- 24 VDC
- 24, 48, 115 or 230 VAC
- Quick release connector blocks

### Approvals



# RT6 Technical Information

## Inputs

The RT6 can be configured to operate in either of the following input options:

1. Single channel, 1 NO contact from +24 V DC, safety category 1.
2. Dual channel, 2 NO contacts from +24 V DC, safety category 3.
3. Dual channel 1 NO, 1 NC contact from +24 V DC, safety category 4.
4. Dual channel, 1 NO contact from 0V and 1 NO contact from +24 V DC, safety category 4.
5. Safety mats/contact strips 1 'contact' from 0V and 1 'contact' from +24 V DC, safety category 1.

*Note: Safety category only refers to the safety relay configuration, input devices, output devices and wiring must be considered for a safety category of the system.*

When the input/inputs are activated and the test/supervised reset is complete, relays 1 and 2 are energized. These are de-energized when the input/inputs are de-activated in accordance with the input option chosen or in case of a power failure. Relays 1 and 2 must both be de-energized before the RT6 can be reset.

## Transistor Output Status Information

The RT6 has two voltage free transistor outputs that can be connected to a PLC, computer or other monitoring device. These outputs give the input and output status of the relay.

## Reset and Testing

The RT6 has two reset options; manual and automatic. The manual supervised reset is used when the RT6 is monitoring safety devices that can be passed through, i.e. to ensure that the outputs of the safety relay do not close just because a gate is closed. The automatic reset should only be used if deemed an acceptable risk.

In addition, the RT6 can also test (supervise), if for example, contactors and valves etc. are de-energized/de-activated before a restart is allowed.

## Indication of Low Voltage

The 'On' LED will flash if the relay supply voltage falls below an acceptable level. This indication will also be given if a monitored safety mat/contact strip is actuated. See connection option 5.

## Safety Level

The RT6 has internal dual and supervised safety functions. Power failure, internal faulty component or external interference will not present a risk to options with the highest safety level. A manual reset requires that the reset input is closed and opened before the safety relay outputs are activated. A short-circuit or a faulty reset button is consequently supervised.

When the RT6 is configured for dual channel input, both the inputs are supervised for correct sequence operation before the unit can be reset.

The input options 3 and 4 have the highest safety levels as all short-circuits and power failures are supervised. This in combination with double internal current limitation makes the relay ideal for supervision of safety mats and contact strips.

## Regulations and Standards

The RT6 is designed and approved in accordance with appropriate directives and standards. Examples of such are: 98/37/EC, EN ISO 12100-1/-2, EN 60204-1 and EN 954-1/EN ISO 13849-1.

## Connection Examples

For examples of how our safety relays can solve various safety problems, see "Connection Examples" beginning on page 5:44.

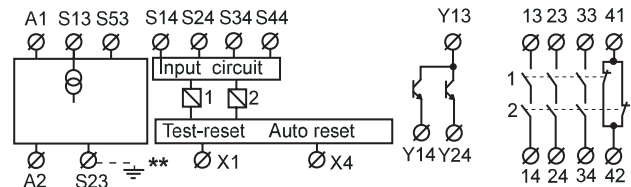

**\*\*Only for AC supply**

## Connection of Supply DC Supply

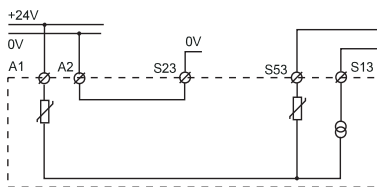

The RT6 DC option should be supplied with +24 V on A1 and 0 V on A2.

## AC Supply

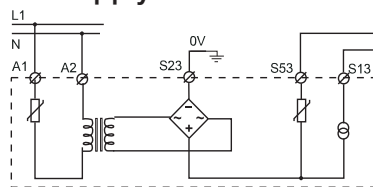

The RT6 AC option should be supplied with the appropriate supply voltage via connections A1 and A2.

The S23/PE must be connected to protective earth.

## DC Supply of AC Units

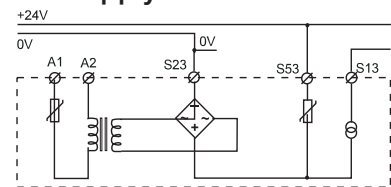

All AC-units can also be supplied by +24 VDC to S53 (0VDC to S23).

*Note: With both DC and AC modules, if cable shielding is used this must be connected to an earth rail or an equivalent earth point.*

## RT6 Connection of Safety Devices

### 1. Single Channel, 1 NO from +24V

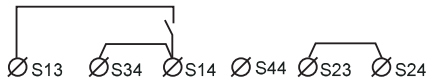

The input (contact to S14) must be closed before the outputs can be activated. When the input contact is opened the relay safety output contacts open.

### 2. Dual Channel, 2 NO from +24V

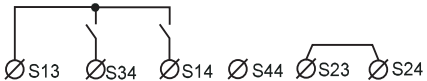

Both input contacts (S14 and S34) must be closed before the relay outputs can be activated. The safety relay contacts will open if one or both of the input contacts are opened. Both the input contacts must be opened and reclosed before the relay can be reset. A short-circuit between inputs S14 and S34 can only be supervised if the device connected to the inputs has short-circuit supervised outputs, e.g. Jokab Focus light curtains.

### 3. Dual Channel, 1 NO, 1 NC from +24V

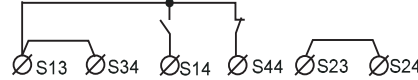

One input contact must be closed (S14) and one opened (S44) before the relay outputs can be activated. The safety relay contacts will open if one or both of the inputs change status or in case of a short-circuit between S14 and S44. Both inputs must return to their initial positions before the relay outputs can be reactivated.

### 4. Dual Channel, 1 NO from +24V, 1 NO to 0V



Relay functions as option 2, but a short-circuit, in this case between inputs S14 and S24, is supervised (safety outputs are opened).

### 5. Safety Mat or Contact Strip

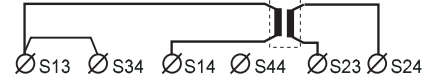

Both 'contact' inputs from an inactivated safety mat/contact strip must be made in order to allow the RT6 relay outputs to be activated. When the safety mat/contact strip is activated or a short-circuit is detected across S14-S23, the relay will de-energize (safety outputs open) and the 'ON' LED will flash. As output S13 has an internal current limit of 80 mA, the RT6 will not be overloaded when the mat/contact strip is activated or a short circuit is detected.

## RT6 Reset Connections

### Manual Supervised Reset

The manual supervised reset contact connected to input X1 must be closed and opened in order to activate the relay outputs.

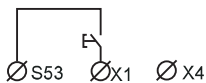

### Automatic Reset

Automatic reset is selected when S53, X1 and X4 are linked. The relay outputs are then activated at the same time as the inputs.

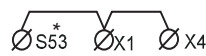

*\*connected to S13 for safety mat/contact strip*

### Testing External Contactor Status

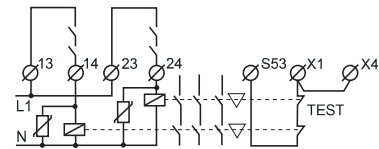

Contactors, relays and valves can be supervised by connecting 'test' contacts between S53 and X1. Both manual supervised and automatic reset can be used.

## RT6 Output Connections

### Relay Outputs

The RT6 has three (3 NO) safety outputs and 1 NC information output.

In order to protect the RT6 output contacts it is recommended that loads (inductive) are suppressed by fitting correctly chosen VDRs, diodes, etc. Diodes are the best arc suppressors, but will increase the switch off time of the load.

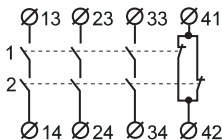

### Transistor Outputs

The RT6 has two (2) voltage free transistor information outputs.

The transistor outputs are supplied with voltage to Y13, either from S53 (+24V) or an external 5-30 VDC. Y14 and Y24 follow the relay inputs and outputs as follows:

- Y14 becomes conductive when the relay input conditions are fulfilled.
- Y24 becomes conductive when both the output relays are activated.

**\*\*\*Note: These outputs are only for information purposes and must not be connected to the safety circuits of the machinery.**

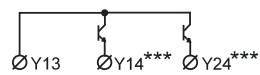



## RT6 Technical Data

<b>Manufacturer</b>	ABB AB/Jokab Safety, Sweden
<b>Ordering information</b>	see page 5:62
<b>Color</b>	Grey
<b>Weight</b>	335 g (24 VDC) 485 g (24-230 VAC)
<b>Supply Voltage (A1-A2)</b>	24 VDC +15/-20%, 24/48/115/230 VAC, +15/-10%, 50-60 Hz
<b>Power consumption</b> DC supply, nominal voltage AC supply, nominal voltage	2.3 W 5.2 VA
<b>Connection S13</b> Short-circuit protected voltage output, 70 mA ± 10% current limitation (Is used for the inputs S14, S34 and S44)	
<b>Connection S53</b> Short-circuit protected voltage output, internal automatic fuse 270 mA (Is used for the reset and autoreset inputs X1 and X4)	
<b>Connection S23</b> 0V connection for input S24	
<b>Safety inputs</b> S14 (+) input S24 (0V) input S34 (+) input S44 (+) input	20 mA 20 mA 20 mA 30 mA
<b>Reset input X1</b> Supply for reset input Reset current	+ 24VDC 300 mA current pulse at contact, then 30 mA
Minimum contact closure time for reset	100 ms
<b>Maximum external connection cable resistance at nominal voltage for</b> S14, S24, S34 S44, X1	300 Ohm 150 Ohm
<b>Response time</b> At Power on DC/AC When activating (input-output) When deactivating (input-output) At Power Loss	<90ms/<220ms <20 ms <20 ms <150 ms
<b>Relay outputs</b> NO NC Maximum switching capacity Resistive load AC Inductive load AC Resistive load DC Inductive load DC Maximum total switching capacity Resistive load Minimum load Contact material Fuses Output (External) Conditional short-circuit current (1 kA) Mechanical life	3 1 6A/250 VAC/1500 VA AC15 240VAC 2A 6A/24 VDC/150 W DC13 24VDC 1A 12A distributed on all contacts 10mA/10 V (if load on contact has not exceeded 100 mA) Ag+Au flash 5A gL/gG 6A gG >10 <sup>7</sup> operations

<b>Transistor outputs</b> External supply to Y13 Y14 Y24 Maximum load of Y14, Y24 Maximum voltage drop at maximum load	Short-circuit proof +5 to +30 VDC Indicates that the input conditions have been fulfilled Indicates that the output relays are activated 15 mA /output 2.4 V
<b>LED indication</b>  On ●  In1 ● In2 ●  ☑ ● 1 ☑ ● 2	Supply voltage OK, the LED is on Flashing light in case of under-voltage or overload Indicates that the input conditions are fulfilled Indicates that the output relays are activated
<b>Mounting</b> Rail	35 mm DIN rail
<b>Connection blocks (detachable)</b> Maximum screw torque Maximum connection area Solid conductors Conductor with socket contact	1 Nm 1x4mm <sup>2</sup> /2x1.5mm <sup>2</sup> /12AWG 1x2.5mm <sup>2</sup> /2x1mm <sup>2</sup>
<b>Protection class</b> Enclosure Connection blocks	IP 40 IEC 60529 IP 20 IEC 60529
<b>Operating temperature range</b>	-10°C to + 55°C (with no icing or condensation)
<b>Operating humidity range</b>	35% to 85%
<b>Impulse withstand voltage</b>	2.5kV
<b>Pollution degree</b>	2
<b>Performance (max.)</b> The relays must be cycled at least once a year	Category 4/PL e (EN ISO 13849-1:2008) SIL 3 (EN 62061:2005) PFH <sub>d</sub> 9.55E-09
<b>Conformity</b>	2006/42/EC, 2006/95/EC 2004/108/EC EN 954-1:1996 EN 62061:2005 EN ISO 13849-1:2008

**Note:**  
Connector blocks are detachable without cables having to be disconnected.

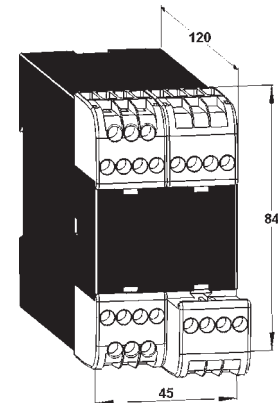

# RT7 Safety Relay

## Universal Relay with Delayed 'Stop' Outputs

The RT7 is a universal relay that can be used to supervise both safety devices and the internal safety of your machinery. In addition, you can select the safety level that is required for each installation. All this is possible because the RT7 has the most versatile input options arrangement available on the market. The RT7 can therefore replace many other relays.

The RT7 has four (4 NO) dual safety outputs of which two may be delayed for up to three seconds in order to achieve a safe and 'soft' stop. A 'soft' stop allows machinery to brake and stop gently before power is removed. A 'soft' stop has many benefits: The machinery life will be prolonged, processed products will not be damaged, and restarts from the stopped position are made possible and easier.

Another option with the RT7 is manual or automatic resetting. A manual supervised reset is used for gates and other safety devices that can be passed through, while an automatic reset is used for small safety hatches if deemed appropriate from a risk point of view.

In addition, the RT7 has information outputs that follow the inputs and outputs of the relay. These outputs indicate if for example a gate is opened or closed, if there is a delay or if the relay needs to be reset.

Choose the RT7 to simplify your safety circuits and reduce your costs.

### Connection Examples

For examples of how our safety relays can solve various safety problems, see "Connection Examples" beginning on page 5:44.



### Applications

- Emergency Stops
- Light Curtains
- Three Position Devices
- Interlocked Gates/Hatches
- Magnetic Switches
- Light Beams
- Safety Mats
- Contact Strips
- Foot-Operated Switches

### Features

- Five input options
- Single or dual channel input
- Manual supervised or automatic reset
- Test input for supervision of external contactors
- Width 45 mm
- LED indication of supply, inputs, outputs, short-circuit and low voltage level
- 4 NO/1 NC relay outputs, 2 NO outputs can be delayed for soft stops
- Delay times: RT7A 0; 0.5; 1.0; 1.5 s  
RT7B 0; 1.0; 2.0; 3.0 s
- Three voltage free transistor information outputs
- 24 VDC
- 24, 48, 115 or 230 VAC
- Quick release connector blocks

### Approvals



# RT7 A/B Technical Information

## Inputs

The RT7 can be configured to operate in either of the following input options:

1. Single channel, 1 NO contact from +24 VDC, safety category 1.
2. Dual channel, 2 NO contacts from +24 VDC, safety category 3.
3. Dual channel 1 NO, 1 NC contact from +24 VDC, safety category 4.
4. Dual channel, 1 NO contact from 0V and 1 NO contact from +24 VDC, safety category 4.
5. Safety mats/contact strips 1 'contact' from 0V and 1 'contact' from +24 VDC, safety category 1.

*Note: Safety category only refers to the safety relay configuration, input devices, output devices and wiring must be considered for a safety category of the system.*

When the input/inputs are activated and the test/supervised reset is complete, relays 1,2,3 and 4 are activated. Relays 1 and 2 are immediately de-energized when the inputs are deactivated in accordance with the input option selected. Relays 3 and 4 are either de-energized immediately or after the selected time delay. All the relays (1,2,3 and 4) must be de-energized before the RT7 can be reset.

## Transistor Output Status Information

The RT7 has three voltage free transistor outputs that can be connected to a PLC, computer or other monitoring device. These outputs give the input and output status of the relay.

## Reset and Testing

The RT7 has two reset options; manual and automatic. The manual supervised reset is used when the RT7 is monitoring safety devices that can be passed through, i.e. to ensure that the outputs of the safety relay do not close just because the gate is closed. The automatic reset should only be used if deemed an acceptable risk.

In addition, the RT7 can also test (supervise), if for example, contactors and valves etc. are de-energized/de-activated before a restart is allowed.

## Indication of Low Voltage

The 'On' LED will flash if the relay supply voltage falls below an acceptable level. This indication will also be given if a monitored safety mat/contact strip is actuated. See connection option 5.

## Safety Level

The RT7 has internal dual and supervised safety functions. Power failure, internal faulty component or external interference will not present a risk to options with the highest safety level. A manual reset requires that the reset input is closed and opened before the safety relay outputs are activated. A short-circuit or a faulty reset button is consequently supervised.

When the RT7 is configured for dual channel input, both the inputs are supervised for correct sequence operation before the unit can be reset.

The input options 3 and 4 have the highest safety levels as all short-circuits and power failures are supervised. This in combination with double internal current limitation makes the relay ideal for supervision of safety mats and contact strips.

## Regulations and Standards

The RT7 is designed and approved in accordance with appropriate directives and standards. Examples of such are: 98/37/EC, EN ISO 12100-1/-2, EN 60204-1 and EN 954-1/EN ISO 13849-1.

## Connection Examples

For examples of how our safety relays can solve various safety problems, see "Connection Examples" beginning on page 5:44.

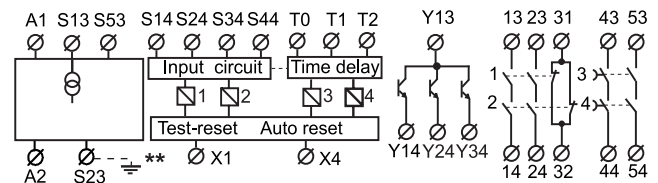

**\*\*Only for AC supply**

## Connection of Supply

### DC Supply

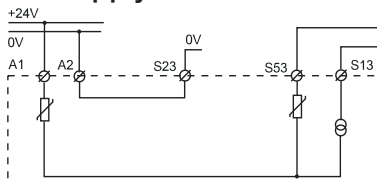

The RT7 DC option should be supplied with +24 V on A1 and 0 V on A2.

### AC Supply

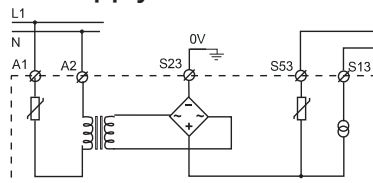

The RT7 AC option should be supplied with the appropriate supply voltage via connections A1 and A2. The S23/⊥ must be connected to protective earth.

### DC Supply of AC Units

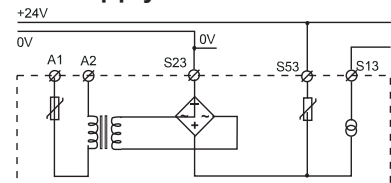

All AC-units can also be supplied by +24 VDC to S53 (0VDC to S23).

*Note: With both DC and AC modules, if cable shielding is used this must be connected to an earth rail or an equivalent earth point.*

## RT7 A/B Connection of Safety Devices

### 1. Single Channel, 1 NO from +24V

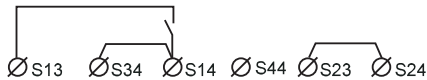

The input (contact to S14) must be closed before the outputs can be activated. When the input contact is opened the relay safety output contacts open.

### 2. Dual Channel, 2 NO from +24V

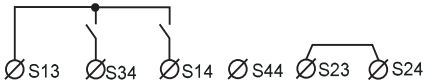

Both input contacts (S14 and S34) must be closed before the relay outputs can be activated. The safety relay contacts will open if one or both of the input contacts are opened. Both the input contacts must be opened and reclosed before the relay can be reset. A short-circuit between inputs S14 and S34 can only be supervised if the device connected to the inputs has short-circuit supervised outputs, e.g. Jokab Focus light curtains.

### 3. Dual Channel, 1 NO, 1 NC from +24V

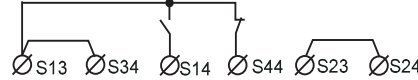

One input contact must be closed (S14) and one opened (S44) before the relay outputs can be activated. The safety relay contacts will open if one or both of the inputs change status or in case of a short-circuit between S14 and S44. Both inputs must return to their initial positions before the relay outputs can be reactivated.

### 4. Dual Channel, 1 NO from +24V, 1 NO to 0V



Relay functions as option 2, but a short-circuit, in this case between inputs S14 and S24, is supervised (safety outputs are opened).

### 5. Safety Mat or Contact Strip

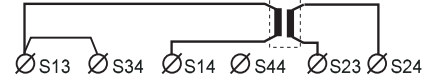

Both 'contact' inputs from an inactivated safety mat/contact strip must be made in order to allow the RT7 relay outputs to be activated. When the safety mat/contact strip is activated or a short-circuit is detected across S14-S23, the relay will de-energize (safety outputs open) and the 'ON' LED will flash. As output S13 has an internal current limit of 60 mA, the RT7 will not be overloaded when the mat/contact strip is activated or a short circuit is detected.

## RT7 A/B Reset Connections

### Manual Supervised Reset

The manual supervised reset contact connected to input X1 must be closed and opened in order to activate the relay outputs.

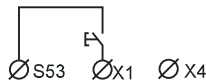

### Automatic Reset

Automatic reset is selected when S53, X1 and X4 are linked. The relay outputs are then activated at the same time as the inputs.



*\*connected to S13 for safety mat/contact strip*

### Testing External Contactor Status

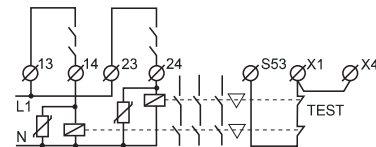

Contactors, relays and valves can be supervised by connecting 'test' contacts between S53 and X1. Both manual supervised and automatic reset can be used.

## RT7 A/B Output Connections

### Relay Outputs

The RT7 has four (4 NO) safety outputs, of which two can be delayed, and 1 NC information output.

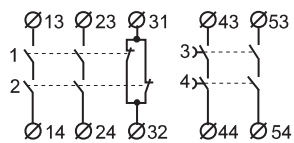

In order to protect the RT7 output contacts it is recommended that loads (inductive) are suppressed by fitting correctly chosen VDRs, diodes, etc. Diodes are the best arc suppressors, but will increase the switch off time of the load.

### Transistor Outputs

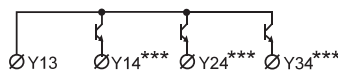

The RT7 has three (3) voltage free transistor information outputs.

The transistor outputs are supplied with voltage to Y13, either from S53 (+24V) or an external 5-30 VDC. Y14, Y24 and Y34 follow the relay inputs and outputs as follows:

- Y14 becomes conductive when the relay input conditions are fulfilled.
- Y24 becomes conductive when both the output relays are activated.
- Y34 becomes conductive when both the delay output relays are activated.

**\*\*\*Note: These outputs are only for information purposes and must not be connected to the safety circuits of the machinery.**

### Time Delay Outputs

RT7A	RT7B	T0	T1	T2	RT7A	RT7B	T0	T1	T2
0.0s	0.0s	Ø	Ø	Ø	1.0s	2.0s	Ø	Ø	Ø
0.5s	1.0s	Ø	Ø	Ø	1.5s	3.0s	Ø	Ø	Ø

Time delays are selected by linking the appropriate T0, T1 and T2 connections.

When a stop signal is detected a program stop command is first given to the PLC/servo which brakes the dangerous machine operations in a 'soft' and controlled way.

The delayed relay safety outputs will then turn off the power to the motors, i.e. when the machinery has already stopped. It takes usually around 0.5 to 3 seconds for a dangerous action to be stopped softly.

# RT7 A/B Technical Data

<b>Manufacturer</b>	ABB AB/Jokab Safety, Sweden		<b>Conditional short-circuit current</b> (1 kA), each output	6A gG
<b>Ordering information</b>	See page 5:62		<b>Mechanical life</b>	>10 <sup>7</sup> operations
<b>Color</b>	Grey		<b>Transistor outputs</b>	+5 to +30 VDC
<b>Weight</b>	405 g (24 VDC) 550 g (24-230 VAC)		External supply to Y13 Y14	Indicates that the input conditions are fulfilled
<b>Supply Voltage (A1-A2)</b>	24 VDC +15/-20%, 24/48/115/230 VAC, ±15%, 50-60 Hz		Y24	Indicates that the output relays 1/2 are activated
<b>Power consumption</b>	DC supply, nominal voltage AC supply, nominal voltage		Y34	Indicates that the delay output relays 3/4 are activated
	4.6 W 8.8 VA		Maximum load of Y14, Y24, Y34 Maximum voltage drop at maximum load	15 mA /output 2.4 V
<b>Connection S13</b>	Short-circuit protected voltage output, 70 mA ±10% current limitation (Is used for the inputs S14, S34 and S44)			
<b>Connection S53</b>	Short-circuit protected voltage output, internal automatic fuse, max 270 mA (Is used for the reset and autoreset inputs X1 and X4)			
<b>Connection S23</b>	0V connection for input S24			
<b>Safety inputs</b>			<b>LED indication</b>	
S14 (+) input		20 mA	On ●	Supply voltage OK, the LED is on. Flashing light in case of under-voltage or overload
S24 (0V) input		20 mA	In1 ● In2 ●	Indicates that the input conditions are fulfilled
S34 (+) input		20 mA	☑ ● 1 ☑ ● 2	Indicates that the output relays 1/2 are activated
S44 (+) input		t ●	Indicates that the delay output relays 3/4 are activated	
<b>Reset input X1</b>	Supply for reset input Reset current		<b>Mounting</b>	
	+ 24VDC 600 mA current pulse at contact closure, then 30 mA		Rail	35 mm DIN rail
Minimum contact closure time for reset	100 ms		<b>Connection blocks (detachable)</b>	
<b>Maximum external connection cable resistance at nominal voltage for</b>			Maximum screw torque	1 Nm
S14, S24, S34	300 Ohm		Maximum connection area	
S44, X1	150 Ohm		Solid conductors	1x4mm <sup>2</sup> /2x1.5mm <sup>2</sup> /12AWG
<b>Response time</b>			Conductor with socket contact	1x2.5mm <sup>2</sup> /2x1mm <sup>2</sup>
At Power on DC/AC	<90/<140 ms		<b>Protection class</b>	
When activating (input-output)	<20 ms		Enclosure	IP 40 IEC 60529
When deactivating (input-output)	<20 ms		Connection blocks	IP 20 IEC 60529
At Power Loss	<80 ms		<b>Operating temperature range</b>	
<b>Delay time options</b>			24VDC	-10° C to + 55° C (with no icing or condensation)
RT7A	0; 0.5; 1.0; 1.5 secs		24-230VAC	-10° C to + 45° C (with no icing or condensation)
RT7B	0; 1.0; 2.0; 3.0 secs		<b>Operating humidity range</b>	35% to 85%
<b>Relay outputs</b>			<b>Impulse withstand voltage</b>	2.5kV
NO direct (relays 1/2)	2		<b>Pollution degree</b>	2
NO direct or delayed (relays 3/4)	2		<b>Performance (max.)</b>	
NC (relays 1/2)	1		The relays must be cycled at least once a year	Category 4/PL e (EN ISO 13849-1:2008) SIL 3 (EN 62061:2005) PFH <sub>d</sub> 9.55E-09
Maximum switching capacity			<b>Conformity</b>	
Relays 1/2 Resistive load AC	6A/250 VAC/1500 VA		2006/42/EC, 2006/95/EC 2004/108/EC EN 954-1:1996, EN 62061:2005 EN ISO 13849-1:2008	
Inductive load AC	AC15 240VAC 2A			
Resistive load DC	6A/24 VDC/150 W			
Inductive load DC	DC13 24VDC 1A			
Relays 1/2 total	Max 9A distributed on all contacts			
Relays 3/4 Resistive load AC	6A/230 VAC/1380 VA			
Inductive load AC	AC15 230VAC 4A			
Resistive load DC	6A/24VDC/144W			
Inductive load DC	DC13 24VDC 2A			
Relays 3/4 total	Max 6A distributed on all contacts			
Contact material	AgSnO <sub>2</sub> + Au flash			
Fuses output 1/2 (external)	5A gL/gG			
Fuses output 3/4 (external)	3A gL/gG			

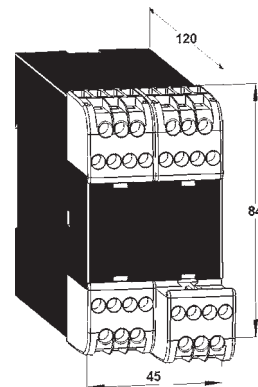

**Note:**  
Connector blocks are detachable without cables having to be disconnected.

# RT9 Safety Relay

## Would you like a small safety relay for all your safety applications?

If so, then choose the compact RT9 universal relay to supervise both your safety devices and the internal safety of your machinery. In addition, you can select the safety level that is required for each installation. All this is possible due to the RT9 offering the most versatile input option arrangement available on the market. The RT9 can therefore replace many other relays.

Other RT9 options include selection of either manual supervised or automatic resetting. The manual supervised reset can be used for gates and other safety devices that can be passed through. Automatic reset can be used for small safety hatches, if deemed acceptable from risk assessment.

In addition, the RT9 has a dual function information output that will indicate, e.g. if a gate is open or if the relay needs resetting.

The RT9 uses the latest component technology and modern assembly techniques to ensure a highly cost effective solution.

Choose the RT9 to simplify your safety circuits and reduce your costs.

### Connection Examples

For examples of how our safety relays can solve various safety problems, see “Connection Examples” beginning on page 5:44.



### Applications

- Emergency Stops
- Light Curtains
- Three Position Devices
- Interlocked Gates/Hatches
- Magnetic Switches
- Light Beams
- Safety Mats
- Contact Strips
- Foot-Operated Switches

### Features

- Five input options
- Single or dual channel input
- Manual supervised or automatic reset
- Test input for supervision of external contactors
- Width 22.5 mm
- LED indication of supply, inputs, outputs, short-circuit and low voltage level
- 2 NO relay outputs
- 1 changeover relay with a dual information output
- 24 VDC
- Detachable connection blocks

### Approvals

TÜV Nord  

# RT9 Technical Information

## Inputs

The RT9 can be configured to operate in either of the following input options:

1. Single channel, 1 NO contact from +24 VDC, safety category 1.
2. Dual channel, 2 NO contacts from +24 VDC, safety category 3.
3. Dual channel, 1 NO, 1 NC contact from +24 VDC, safety category 4.
4. Dual channel, 1 NO contact from 0V and 1 NO contact from +24 VDC, safety category 4.
5. Safety mats/contact strips 1 'contact' from 0V and 1 'contact' from +24 VDC, safety category 1.

*Note: Safety category only refers to the safety relay configuration, input devices, output devices and wiring must be considered for a safety category of the system.*

When the input/inputs are activated and the test/supervised reset is complete, relays 1 and 2 are energized. These are de-energized when the input/ inputs are de-activated in accordance with the input option chosen or in case of a power failure. Relays 1 and 2 must both be de-energized before the RT9 can be reset.

## Transistor Output Status Information

The RT9 has a changeover contact relay output that can be connected to a PLC, control lamp, computer or similar. The output gives information about the status of the relay.

## Reset and Testing

The RT9 has two reset options; manual and automatic. The manual supervised reset is used when the RT9 is monitoring safety devices that can be passed through, i.e. to ensure that the outputs of the safety relay do not close just because a gate is closed. The automatic reset should only be used if deemed an acceptable risk.

Due to special internal circuits the RT9 can be automatically reset regardless of the operational voltage rise time, this being an important factor when large loads are started up on the same power supplies at the same time.

In addition, the RT9 can also test (supervise), if for example, contactors and valves, etc. are de-energized/ de-activated before a restart is made.

## Connection of Supply DC Supply

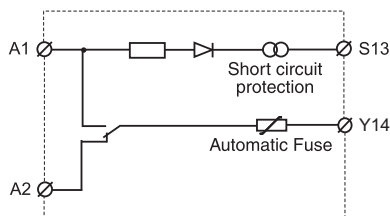

The RT9 should be supplied with +24 V on A1 and 0 V on A2.

*Note: If cable shielding is used this must be connected to an earth rail or an equivalent earth point.*

## Indication of Low Voltage

The 'On' LED will flash if the relay supply voltage falls below an acceptable level. This indication will also be given if a monitored safety mat/contact strip is actuated.

## Safety Level

The RT9 has internal dual and supervised safety functions. Power failure, internal faulty component or external interference will not present a risk to options with the highest safety level. A manual reset requires that the reset input is closed and opened before the safety relay outputs are activated. A short-circuit or a faulty reset button is consequently supervised.

When the RT9 is configured for dual channel input, both the inputs are supervised for correct operation before the unit can be reset.

The input options 3 and 4 have the highest safety levels as all short-circuits and power failures are supervised. This in combination with double internal current limitation makes the relay ideal for supervision of safety mats and contact strips.

## Regulations and Standards

The RT9 is designed and approved in accordance with appropriate directives and standards. Examples of such are: 98/37/EC, EN ISO 12100-1/-2, EN 60204-1 and EN 954-1/EN ISO 13849-1.

## Connection Examples

For examples of how our safety relays can solve various safety problems, see "Connection Examples" beginning on page 5:44.

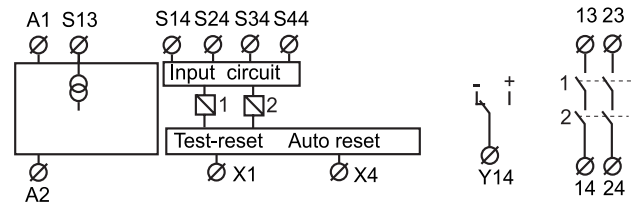

## RT9 Connection of Safety Devices

### 1. Single Channel, 1 NO from +24V

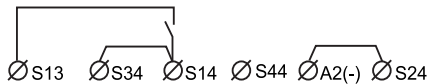

The input (contact to S14) must be closed before the outputs can be activated. When the input contact is opened the relay safety output contacts open.

### 2. Dual Channel, 2 NO from +24V

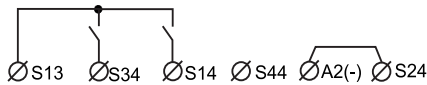

Both input contacts (S14 and S34) must be closed before the relay outputs can be activated. The safety relay contacts will open if one or both of the input contacts are opened. Both the input contacts must be opened and reclosed before the relay can be reset. A short-circuit between inputs S14 and S34 can only be supervised if the device connected to the inputs has short-circuit supervised outputs, e.g. Jokab Focus light curtains.

### 3. Dual Channel, 1 NO, 1 NC from +24V

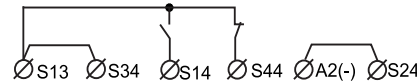

One input contact must be closed (S14) and one opened (S44) before the relay outputs can be activated. The safety relay contacts will open if one or both of the inputs change status or in case of a short-circuit between S14 and S44. Both inputs must return to their initial positions before the relay outputs can be reactivated.

### 4. Dual Channel, 1 NO from +24V, 1 NO to 0V



Relay functions as option 2, but a short-circuit, in this case between inputs S14 and S24, is supervised (safety outputs are opened).

### 5. Safety Mat or Contact Strip

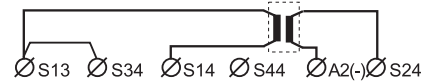

Both 'contact' inputs from an inactivated safety mat/contact strip must be made in order to allow the RT9 relay outputs to be activated. When the safety mat/contact strip is activated or a short-circuit is detected across S14-S23, the relay will de-energize (safety outputs open) and the 'ON' LED will flash. As output S13 has an internal current limit of 85 mA, the RT9 will not be overloaded when the mat/contact strip is activated or a short circuit is detected.

## RT9 Reset Connections

### Manual Supervised Reset

The manual supervised reset contact connected to input X1 must be closed and opened in order to activate the relay outputs.

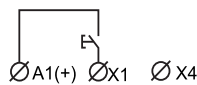

The manual supervised reset contact connected to input X1 must be closed and opened in order to activate the relay outputs.

### Automatic Reset

Automatic reset is selected when A1(+), X1 and X4 are linked. The relay outputs are then activated at the same time as the inputs.

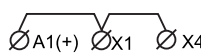

### Testing External Contactor Status

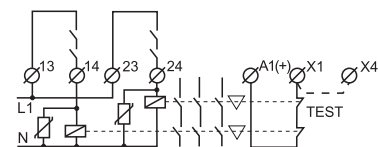

Contactors, relays and valves can be supervised by connecting 'test' contacts between A1(+) and X1. Both manual supervised and automatic reset can be used.

## RT9 Output Connections

### Relay Outputs

The RT9 has two (2 NO) safety outputs.

In order to protect the RT9 output contacts it is recommended that loads (inductive) are suppressed by fitting correctly chosen VDRs, diodes, etc. Diodes are the best arc suppressors, but will increase the switch off time of the load.

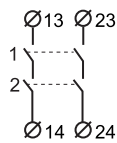

### Transistor Outputs

The RT9 has a changeover contact information output.

The relay output Y14 is connected internally to 0V and 24V in the following way:

- Y14 is internally closed to 0V when the RT9 is not reset.
- Y14 is internally closed to +24V when the RT9 is reset.

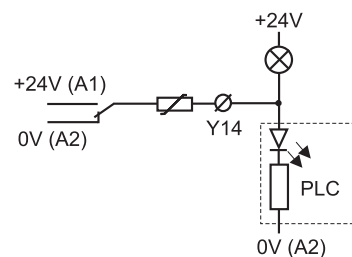



## RT9 Technical Data

Manufacturer	ABB AB/Jokab Safety, Sweden
Ordering information	see page 5:63
Color	Grey
Weight	210 g
Supply Voltage (A1-A2)	24 VDC $\pm$ 20%
Power consumption Nominal voltage	2 W
Connection S13	Short-circuit protected voltage output 70 mA $\pm$ 10% current limitation (Is used for the inputs S14, S34 and S44)
Input currents (at nominal supply voltage)	
S14 (+) input	30 mA
S24 (0V) input	20 mA
S34 (+) input	20 mA
S44 (+) input	25 mA
Reset input X1 Supply for reset input Reset current	+ 24VDC 300 mA current pulse at contact closure, then 30 mA
Minimum contact closure time for reset	80 ms
Minimum contact closure time (at low limit voltage -20%)	100 ms
Maximum external connection cable resistance at a nominal voltage for S14, S24, S34 S44, X1	300 Ohm 150 Ohm
Response time	
At Power on	<100 ms
When activating (input-output)	<20 ms
When deactivating (input-output)	<20 ms
At Power Loss	<80 ms
Relay outputs	
NO	2
Maximum switching capacity	6A/250 VAC/1500 VA
Resistive load AC	AC15 240VAC 2A
Inductive load AC	6A/24 VDC/150 W
Resistive load DC	DC13 24VDC 1A
Inductive load DC	8A distributed on all contacts
Max. total switching capacity	
Minimum load	10 mA/10V (if load on contact has not exceeded 100 mA)
Contact material	Ag+Au flash
Fuses output (external)	5A gL/gG
Conditional short-circuit current (1 kA)	6A gG
Mechanical life	10 <sup>7</sup> operations
Relay information output Y14 (changeover contacts)	
-(0V)	Indicates that RT9 is not reset.
+(24V)	Indicates that RT9 is reset.
Maximum load of Y14	250 mA
Short-circuit protection for information output	Internal automatic fuse

LED indication	
On ●	Supply voltage OK, the LED is on Flashing light in case of under-voltage, overload or current limiting
In1 ● In2 ●	Indicates that the input conditions are fulfilled
☑ ● 1 ☑ ● 2	Indicates that the output relays have been activated
Mounting Rail	35 mm DIN rail
Connection blocks (detachable) Maximum screw torque Maximum connection area Solid conductors Conductor with socket contact	1 Nm 1x4mm <sup>2</sup> /2x1.5mm <sup>2</sup> /12AWG 1x2.5mm <sup>2</sup> /2x1mm <sup>2</sup>
Protection class Enclosure Connection blocks	IP 40 IEC 60529 IP 20 IEC 60529
Operating temperature range	-10°C to + 55°C (with no icing or condensation)
Operating humidity range	35% to 85%
Impulse withstand voltage	2.5kV
Pollution degree	2
Performance (max.) The relays must be cycled at least once a year	Category 4/PL e (EN ISO 13849-1:2008) SIL 3 (EN 62061:2005) PFH <sub>d</sub> 9.55E-09
Conformity	2006/42/EC, 2006/95/EC 2004/108/EC EN 954-1:1996, EN 62061:2005 EN ISO 13849-1:2008

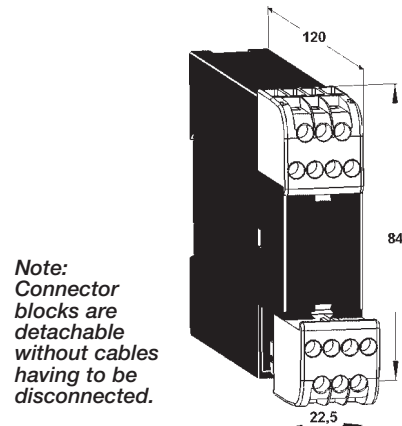

# JSBRT11 Safety Relay

## Flexible Safety Relay with Various Outputs

The JSBRT11 has been designed to provide the safety system circuit designer with the ability to select from both a range of input connection configurations and either automatic or supervised reset.

The unit can be hardware configured to operate in either of the following input configurations:

- Mode 1: Single Channel (1 NO contact from +24 VDC), safety category 1
- Mode 2: Dual Channel (2 NO contacts from +24 VDC), safety category 3
- Mode 3: Dual Channel (1NO, 1 NC contacts from +24 VDC), safety category 4
- Mode 5: Dual Channel (1 NO) contact from 0 V and 1 NO contact from +24 VDC), safety category 4

In addition, the unit can also be used to test that contactors and valves have fallen/returned to their 'reset' state before a new 'start' signal is given.

### Safety Level

The JSBRT11 has dual and monitored internal safety functions. Power failure, internal component failures or external interference (with the exception of short circuiting of input contact when used in a single channel input mode) do not result in a dangerous function.

When wired for supervised reset, should a short circuit appear across the reset input the relay will not automatically reset when the input/inputs are made. Only when the supervised reset input is made and broken will the relay reset.

The JSBRT11 provides detection of contact failure in the inputs when wired in dual channel mode. Both inputs have to be opened and closed in order to enable the reactivation of the relay. The highest safety level of the JSBRT11 is in configuration mode 3 or 4 because all short circuits are supervised, i.e. a short circuit between the inputs leads to a safe state as the outputs drop out.

### Connection Examples

For examples of how our safety relays can solve various safety problems, see "Connection Examples" beginning on page 5:44.

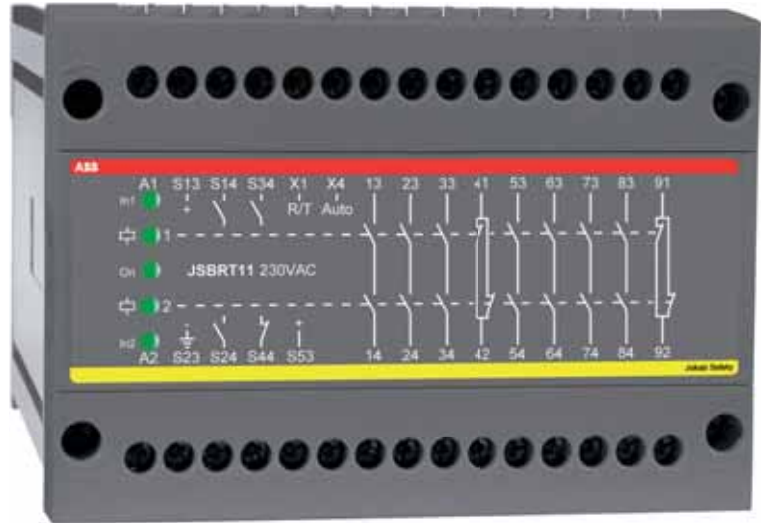

### Applications

- Emergency Stops
- Light Curtains
- Three Position Devices
- Interlocked Gates/Hatches
- Magnetic Switches
- Light Beams
- Foot-Operated Switches

### Features

- Selectable inputs and safety category
- Manual supervised or automatic reset
- Width 100 mm
- LED indication of supply, inputs and outputs
- 7 NO + 2 NC relay outputs
- Supply 24 VDC 24, 48, 115 or 230 VAC
- Quick release connector blocks

### Regulations and Standards

The JSBRT11 is designed and approved in accordance with appropriate directives and standards. See Technical Data.

### Approvals

TÜV Nord  

# JSBRT11 Technical Data

Manufacturer	ABB AB/Jokab Safety, Sweden	Response time at activation (input-output)	<30 ms
Ordering information	see page 5:63	Terminals (max. screw torque 1 Nm)	
Color	Grey	Single strand	1x4 mm <sup>2</sup> /2x1.5 mm <sup>2</sup>
Power supply A1 - A2	24 VDC ± 15% 24, 48, 115, 230 VAC ± 15%, 50-60 Hz	Conductor with socket contact	1x2.5 mm <sup>2</sup> /2x1mm <sup>2</sup>
Power consumption	3.2 W/7.9 VA	Mounting	35 mm DIN-rail
Relay outputs	7 NO and 2 NC	Protection class	
Maximum switching capacity		Enclosure	IP 40 IEC 60259
Resistive load AC	6A/250 VAC/1500 VA	Terminals	IP 20 IEC 60259
Inductive load AC	AC15 240VAC 2A	Impulse withstand voltage	2.5kV
Resistive load DC	6A/24 VDC/150 W	Pollution degree	2
Inductive load DC	DC13 24VDC 1A	Operating temperature range	-10°C to +55°C (with no icing or condensation)
Max. total switching capacity	21A distributed on all contacts	Operating humidity range	35% to 85%
Minimum load	10mA/10 V (if load on contact has not exceeded 100 mA)	Function indication	Electrical Supply, Input 1 and 2, Output relays 1 and 2
Contact material	AgSnO <sub>2</sub> + Au flash	Weight	610 g (24 VDC) 790 g (24-230 VAC)
Fuses output (external)	6A gL/gG	Performance (max.)	Category 4/PL e
Conditional short-circuit current (1 kA)	6A gG	Functional test	(EN ISO 13849-1:2008)
Maximum input wire res. at nom. voltage	200 Ohm (S14,S24,S34,X1,X4); 100 Ohm (S44)	The relays must be cycled at least once a year	SIL 3 (EN 62061:2005) PFH <sub>d</sub> 1.69E-08
Response time at deactivation (input-output)	<20 ms	Conformity	2006/42/EC, 2006/95/EC 2004/108/EC EN 954-1:1996, EN 62061:2005 EN ISO 13849-1:2008

## JSBRT11 Technical Description

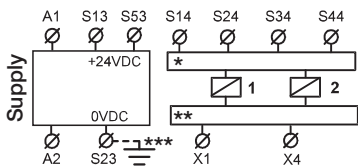

The supply voltage is connected across A1 and A2. The input connection configuration and type of reset required is set by connecting the unit as shown in the diagrams below. When the input/inputs and the test/supervised reset are made K1 and K2 energize. K1 and K2 will de-energize if the power is disconnected or a stop signal is given in accordance to the configuration mode wired. Both K1 and K2 have to be deactivated before the outputs of the JSBRT11 can be closed again.

### Configuration Mode 1

When the single input opens both K1 and K2 relays are deactivated.

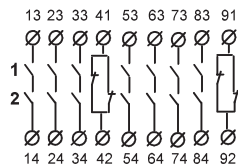

### Configuration Mode 2

Both inputs have to be closed in order to enable the unit to be activated. A stop signal is given if both or one input is opened. Both inputs have to be opened and reclosed in order to enable the reactivation of the unit. If the possibility of short circuits between the inputs cannot be excluded, configuration mode 3 or 4 should be used in order to reach the high safety level.

### Configuration Mode 3

One input has to be closed and the other input has to be opened in order to enable the unit to be activated. A stop signal is given if both or one input change state. Both inputs have to change state in order to give a dual stop function and to allow a new start after stop.

### Configuration Mode 4

Operation as mode 2 but short circuits between the inputs leads to a safe state, i.e. the relays inside the JSBRT11 will drop out.

### Supervised reset connection

The input to X1 (see diagram below) has to be closed and opened in order to activate the unit, after input/inputs are made according to the configuration mode selected. This mode is selected when X1 - X4 is open circuit.

### Automatic reset connection

The input has to be closed in order to activate the unit after input/inputs are made according to the configuration mode selected. This mode is selected when a connection between X1 and X4 is made.

### Test

Test contacts of contactors can be connected between S53 and X1 for supervision.

## JSBRT11 Electrical Connections

### Single Channel,\* (Mode 1)

1 NO from +24V



### Dual Channel,\* (Mode 2)

2 NO from +24V

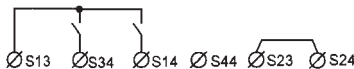

### Dual Channel,\* (Mode 3)

1 NO, 1 NC from +24V

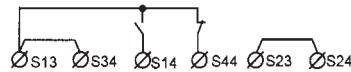

### Dual Channel,\* (Mode 4)

1 NO from +24V, 1 NO to 0V

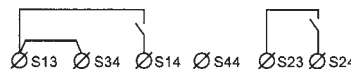

### Supervised Manual Reset

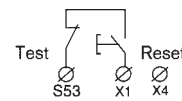

### Automatic Reset

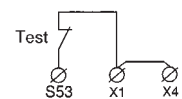

\*Note: With the input conditions shown, the JSBRT11 is in its de-energized state, i.e. output contacts are open. It is recommended that all switched loads are adequately suppressed and/or fused in order to provide additional protection for the safety contacts.

# JSBR4 Safety Relay

## Universal Relay for Two-Handed Devices

The JSBR4 has two inputs, which both have to be closed to keep the safety output contacts closed. A short circuit across the inputs will cause the output contacts to open. The inputs can however be subjected to a continuous short circuit without damaging the safety relay.

In order to make the safety outputs close the reset input must be closed and opened. In this way an unintentional reset is prevented in the case of a short circuit in the reset button cable or if the button gets jammed in the actuated position. The reset input can also be used for test/supervision to ensure that contactors or valves have returned to their initial off "stop" position before a new start can be allowed by the safety relay.

When the JSBR4 is used as a Two Hand relay both buttons have to be pressed within 0.5 seconds of each other in order to close the outputs.

When the JSBR4 is used for Safety Mats and Safety Strips the "stop" condition is given following detection of a short circuit between input channels A and B. Neither the safety mat, safety strip nor the relay will be damaged by a continuous short circuit. This also gives the advantage that if there is a failure between the inputs in the installation, the safety relay will not be damaged.

### Safety Level

The JSBR4 has a twin supervised safety function. Neither component failure, short circuit or external disturbances (power loss, etc.) will prevent the safe function of the relay. This is valid both for the inputs A and B as well as for the reset input. The JSBR4 operates at the highest safety level for safety relays (PL e according to EN ISO 13849-1).

### Connection Examples

For examples of how our safety relays can solve various safety problems, see "Connection Examples" beginning on page 5:44.



### Applications

- Two-Handed Devices of Type IIIc
- Emergency Stops
- Three Position Devices
- Interlocked Gates/Hatches
- Safety Mats
- Contact Strips
- Foot-Operated Switches

### Features

- Dual input channels synchronism 0.5s
- Supervised reset
- Test input
- Width 45 mm
- LED indication of supply, inputs and outputs
- 3 NO/1 NC relay outputs
- 24 VDC
- 24, 48, 115 or 230 VAC
- Quick release connector blocks

### Regulations and Standards

The JSBR4 is designed and approved in accordance with appropriate directives and standards. See Technical Data.

The JSBR4 complies with the highest safety level for connection of a two-hand control device of type IIIc in accordance with EN574.

### Approvals



# JSBR4 Technical Data

Manufacturer	ABB AB/Jokab Safety, Sweden
Ordering information	see page 5:63
Color	Grey
Power supply	24 VDC ± 15% 24/48/115/230 VAC ± 15%, 50 - 60 Hz
Power consumption	1.3 W/3.3 VA
Relay outputs	3 NO + 1 NC
Maximum switching capacity	Resistive load AC 6A/250 VAC/1500 VA Inductive load AC AC15 240VAC 2A Resistive load DC 6A/24 VDC/150 W Inductive load DC DC13 24VDC 1A
Maximum res. load total switching capacity	12A distributed on all contacts
Minimum load	10mA/10 V (if load on contact has not exceeded 100 mA)
Contact material	Ag + Au flash
Fuses output (external)	5A gL/gG
Conditional short-circuit current (1 kA)	6A gG
Maximum input wire res. at nom. voltage	300 Ohm (S13 - S14 and S23 - S24)
Response time at deactivation	< 20 ms (145 ms at power loss)
Terminals (max. screw torque 1 Nm)	
Single strand	1 x 2.5 mm <sup>2</sup> /2 x 1 mm <sup>2</sup>
Conductor with socket contact	1 x 4 mm <sup>2</sup> /2 x 1.5 mm <sup>2</sup>
Mounting	35 mm DIN-rail

Protection class	IP 40/20 IEC 60529
Enclosure/Terminals	
Operating temperature range	-10°C to +55°C (with no icing or condensation)
Impulse withstand voltage	2.5kV
Pollution degree	2
Operating humidity range	35% to 85%
LED indication	Electrical Supply, Inputs, Outputs
Weight	350 g (24 VDC), 460 g (24-230 VAC)
Values	Safety Category 4 according to EN 954-1, PL e, SIL 3, PFH <sub>d</sub> 1.35E-08
With proof test interval 1 year	
Conformity	2006/42/EC, 2006/95/EC, 2004/108/EC, EN 954-1:1996, EN 62061:2005, EN ISO 13849-1:2008

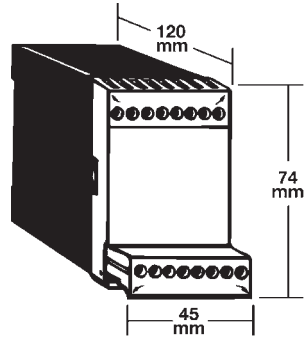

**Note:** Connector blocks are detachable without cables having to be disconnected.

## JSBR4 Technical Description

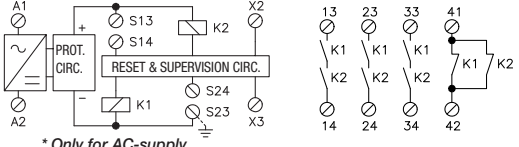

The electrical supply is connected across A1 and A2. After Voltage reduction and Rectification (AC-versions) or reverse polarization protection (DC-version) there is an overload protection-circuit. When the inputs S13-S14 and S23-S24 have closed and the reset is made, the relays K1 and K2 are activated.

A dual stop signal is given when K1 and K2 drop, due to short circuiting between the inputs, opening of the inputs or power failure. If one input is opened the other input must also be opened for K1 and K2 to be activated again.

The monitoring circuit checks K1 and K2 and that the reset circuit to X2 is both closed and opened before K1 and K2 are energized. Both the stop and reset function therefore comply with the requirement that a component fault, short circuit or external interference do not result in a dangerous function. The safety outputs consist of contacts from

K1 and K2 connected internally in series across terminals 13 - 14, 23 - 24 and 33 - 34. These contacts are used to cut the power to components which stop or prevent hazardous movements/functions. It is recommended that all switched loads are adequately suppressed and/or fused in order to provide additional protection for the safety contacts.

**Note:** Output 41-42 is intended for the indication purposes only, e.g. gate opened. No load between S14 and S24 allowed.

## JSBR4 Electrical Connections

Emergency stop with manual resetting.

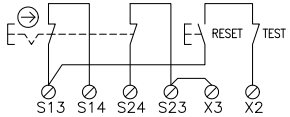

Interlocked gate with manual reset.

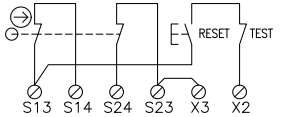

Contact mat or strip with manual reset.

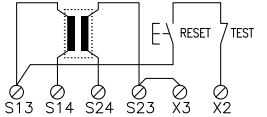

Two-hand device with buttons in separate or same enclosure. Buttons to be pressed in within 0.5 s of each other. Foot-pedal switches can be connected in the same configuration.

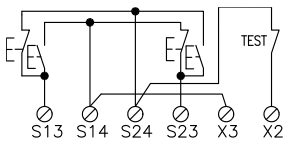

Enabling device JSHD4. Stop condition is given in both top and bottom PB positions.

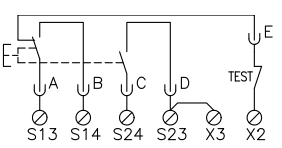

Control and supervision of external contactors, relay, valve or Jokab Safety's expansion relays.

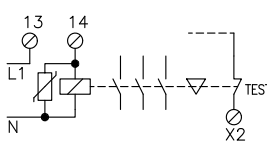

# JSBT4 Safety Relay

## Safety Relay with Synchronized Dual Input Channels (within 0.5s)

The JSBT4 has two inputs, both of which have to be closed in order to keep the safety output contacts closed. A short circuit between inputs A and B will cause the output contacts to open. The inputs can be continuously short circuit without damaging the safety relay.

For the outputs to close, the test input must be closed. The test input is intended to monitor that contactors or valves have dropped/returned before a new start is permitted.

This test input must not be confused with the reset function required for gates that a person can walk through and where there is a high safety requirement (see JSBR4).

If the JSBT4 is used for safety Mats and Safety Strips, the "stop" condition is given following detection of a short circuit. Neither the Safety Mat, Safety Strip nor the relay will be damaged by a continuous short circuit. This also provides the advantage that if there is a failure between inputs A and B in the installation, the safety relay will not be damaged.

### Safety Level

The JSBT4 has a twin supervised safety function. Neither component failure, short circuit or external disturbances (power loss, etc.) will prevent the safe function of the relay. (Category 3 or 4 depending on use.)

The true two channel safety function has the advantage that the cabling installation demands for safety can be reduced due to the fact that a short circuit between the inputs will directly open the relays safety outputs.

### Connection Examples

For examples of how our safety relays can solve various safety problems, see "Connection Examples" beginning on page 5:44.



### Applications

- Emergency Stops
- Three Position Devices
- Interlocked Gates/Hatches
- Safety Mats
- Contact Strips
- Foot-Operated Switches

### Features

- Dual channel input synchronism 0.5 s
- Test input
- Width 45 mm
- LED indication of power on, inputs and outputs
- 3 NO/1 NC relay outputs
- 24 VDC
- 24, 48, 115 or 230 VAC
- Quick release connector blocks

### Regulations and Standards

The JSBT4 is designed and approved in accordance with appropriate directives and standards. See Technical Data.

### Approvals

TÜV Nord  

# JSBT4 Technical Data

Manufacturer	ABB AB/Jokab Safety, Sweden
Ordering information	see page 5:64
Color	Grey
Power supply	24 VDC ± 15% 24/48/115/230VAC ± 15%, 50 - 60 Hz
Power consumption	1.6 W/3.8 VA
Relay outputs	3 NO + 1 NC
Maximum switching capacity	Resistive load AC 6A/250 VAC/1500 VA Inductive load AC AC15 240VAC 2A Resistive load DC 6A/24 VDC/150 W Inductive load DC DC13 24VDC 1A
Maximum res. load total switching capacity	12A distributed on all contacts
Minimum load	10mA/10 V (if load on contact has not exceeded 100 mA)
Contact material	Ag + Au flash
Fuses output (external)	5A gL/gG
Conditional short-circuit current (1 kA)	6A gG
Maximum input wire res. at nom. voltage	300 Ohm (S13 - S14 and S23 - S24)
Response time at deactivation	< 20 ms, 145 ms with switched supply/power loss

Terminals (max. screw torque 1 Nm)	
Single strand	1 x 4 mm <sup>2</sup> /2 x 1.5 mm <sup>2</sup>
Conductor with socket contact	1 x 2.5 mm <sup>2</sup> /2 x 1 mm <sup>2</sup>
Mounting	35 mm DIN-rail
Protection class	
Enclosure/Terminals	IP 40/20 IEC 60529
Operating temperature range	-10°C to +55°C (with no icing or condensation)
Impulse withstand voltage	2.5kV
Pollution degree	2
Operating humidity range	35% to 85%
LED indication	Electrical Supply, Inputs, Outputs
Weight	350 g (24VDC), 460 g (24-230VAC)
Values	
With proof test interval 1 year	Safety Category 4 according to EN 954-1, PL e, SIL 3, PFH <sub>d</sub> 1.51E-08
Conformity	2006/42/EC 2006/95/EC 2004/108/EC EN 954-1:1996, EN 62061:2005 EN ISO 13849-1:2008

## JSBT4 Technical Description

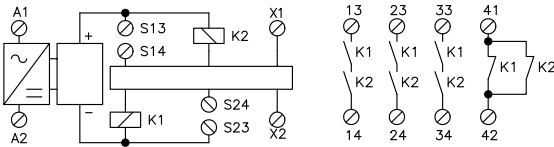

The electrical supply is connected across A1 and A2. After Voltage reduction and Rectification (AC-versions) or reverse polarization protection (DC-version) there is an overload protection-circuit.

When the inputs S13-S14 and S23- S24 are closed within 0.5 seconds the relays K1 and K2 are energized . A dual stop signal is given, K1 and K2 de-energize, when there is a short circuit between an

opening of the inputs and at power loss. If one input is opened the other one also has to be opened in order to activate K1 and K2 again. The test circuit, X1- X2, has to be closed in order to activate the outputs, thereafter the test circuit can be opened or closed continuously. If the test circuit is closed after the inputs there is no requirement to close them within 0.5 seconds.

The internal supervision circuit monitors the two Inputs and relays K1, K2. The stop function then fulfills the requirement that one failure (short circuit, component, external disturbance) shall not prevent the safe function of the JSBT4.

The safety outputs consist of contacts from K1 and K2 connected internally in series across terminals 13-14, 23-24 and 33-34. These contacts are used to cut the power to components which stop or prevent hazardous movements/functions. It is recommended that all switched loads are adequately suppressed and/or fused in order to provide additional protection for the safety contacts.

The NC output 41-42 should only be used for monitoring purpose e.g. Indication lamp or PLC input, etc. The output contacts are closed until the module is reset.

*Note: Output 41-42 is intended for the indication purposes only, e.g. gate opened. No load between S14 and S24 allowed.*

## JSBT4 Electrical Connections

Emergency stop with automatic resetting.

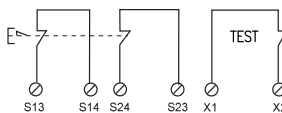

Interlocked hatch with automatic resetting.

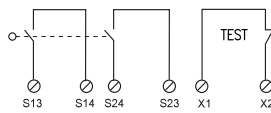

Contact mat or strip with automatic reset.

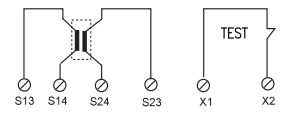

Monitoring to ensure that the Start button cannot stick in pressed position. Short circuiting over the closing contact is not monitored. The RT-series and JSBR4 have built-in short circuiting monitored resetting.

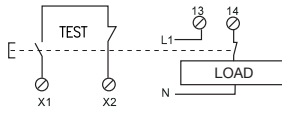

Enabling device JSHD4. Stop condition is given in both top and bottom PB positions.

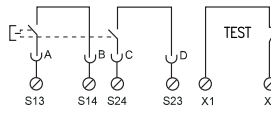

Control and supervision of external contactors, relay, valve or Jokab Safety's expansion relays.

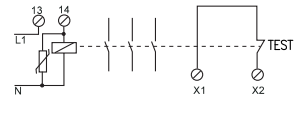

# BT50(T) Safety Relay/ Expansion Relay

## Single Channel Safety Relay

The BT50 is designed to connect safety devices, such as emergency stops, directly in the voltage supply circuit to the relay. Despite a maximum built-in width of only 22.5 mm, the relay is very powerful.

With 3 NO safety outputs, 1 NC output (for monitoring purposes), a test input and complete internal supervision, the BT50 is quite unique. In addition, delayed outputs (BT50T) can be ordered.

In order for the safety outputs to close, the supply voltage, by means of an emergency stop button, must be connected to A1 and A2 and the test input closed. After actuation of the relay the test input can be opened again.

The test input is intended to supervise that contactors or valves have dropped/returned before a new start can be permitted. The test input can also be used for starting and the start button can be supervised (see Connection Example on next page).

## More Outputs

By connecting BT50 to a safety relay/PLC it is easy to increase the number of safe outputs. This means that an unlimited number of dangerous machine operations and functions can be stopped from one safety relay/PLC.

## Safety Level

The BT50 has a twin and supervised internal safety function. Power failure, internal component faults or external interference cannot result in dangerous functions.

Input via A1 only is not protected from short circuiting and therefore installation is critical for the safety level to be achieved. To achieve a higher safety level, a screened cable can be used and/or connection made to both A1 and A2 (see Technical Description on next page).

## Connection Examples

For examples of how our safety relays can solve various safety problems, see “Connection Examples” beginning on page 5:44.



## Applications

- Emergency Stops
- Interlocked Hatches
- Expansion of Safety Outputs

## Features

- Width 22.5 mm
- LED indication
- 3 NO/1 NC relay outputs
- Test/reset input
- 24 VDC
- Single or dual channel
- BT50 - Additional power terminals
- Quick release connector blocks
- BT50T - 1 changeover relay with a double information output (Y14)
- BT50T - Delay times selectable from 0 to 1.5 s

## Regulations and Standards

The BT50 is designed and approved in accordance with appropriate directives and standards. See Technical Data.

## Approvals

TÜV Nord  



# BT50(T) Technical Data

Manufacturer	ABB AB/Jokab Safety, Sweden
Ordering information	see page 5:64
Color	Grey
Operational voltage	24 VDC + 15%/-25%
Power consumption	1.4 W/1.8 W
Relay outputs	3 NO + 1 NC
Maximum switching capacity	
Resistive load AC	6A/250 VAC/1500 VA
Inductive load AC	AC15 240VAC 2A
Resistive load DC	6A/24 VDC/150 W
Inductive load DC	DC13 24VDC 1A
Maximum res. load total switching capacity	12A distributed on all contacts
Minimum load	10mA/10 V(if load on contact has not exceeded 100 mA)
Contact material	Ag + Au flash
Fuses output (external)	5A gL/gG
Conditional short-circuit current (1 kA)	6A gG
Maximum input wire res. at nom. voltage	200 Ohms
Response time at deactivation (input - output)	Version B <20 ms or delayed max 1500 ms (old version of BT50 <60 ms)

Terminals (max. screw torque 1 Nm)	
Single strand	2x1.5 mm <sup>2</sup>
Conductor with socket contact	2x1mm <sup>2</sup>
Mounting	35 mm DIN-rail
Protection class	
Enclosure/Terminals	IP 40/20 IEC 60529
Impulse withstand voltage	2.5kV
Pollution degree	2
Operating temperature range	-10°C to +55°C (with no icing or condensation)
Operating humidity range	35% to 85%
LED indication	Electrical Supply, Relay and X4
Weight	200 g
Performance (max.)	
Functional test	Category 4/PL e (EN ISO 13849-1:2008)
The relays must be cycled at least once a year	SIL 3 (EN 62061:2005) PFH <sub>d</sub> 1.22E-08
Conformity	2006/42/EC, 2006/95/EC 2004/108/EC EN 954-1:1996, EN 62061:2005 EN ISO 13849-1:2008

## BT50(T) Technical Description

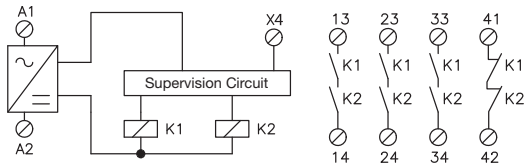

K1 and K2 have dropped before they can be reactivated. The stop function complies with the requirement that a component fault or external interference cannot lead to a dangerous function.

When supply voltage is connected to A1 and A2, relays K1 and K2 are activated. K1 and K2 drop if the supply voltage is disconnected. Both relays K1 and K2 must drop for them to be activated again. The test circuit, A1 - X4 can either be open or constantly closed.

The safety outputs consist of contacts from K1 and K2 connected internally in series across terminals 13-14, 23-24, and 33-34. These contacts are used to cut the power to components which stop or prevent hazardous movements/functions. It is recommended that all switched loads are adequately suppressed and/or fused in order to provide

additional protection for the safety contacts. The NC output 41-42 should only be used for monitoring purposes e.g. indication lamp for emergency stop pressed.

### JSB50T Information Output

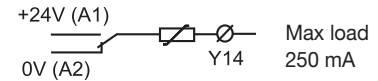

### JSBT50T Delay Times

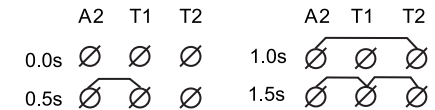

## BT50(T) Electrical Connections

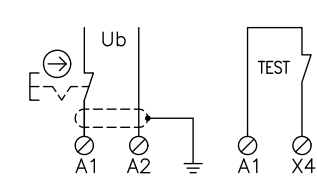

Emergency stop with reset when emergency button returns.

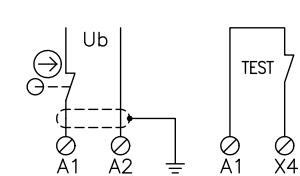

Hatch with automatic reset.

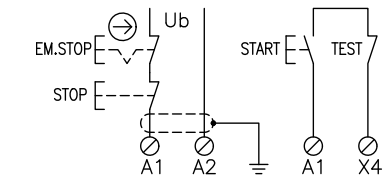

JSBT50 as emergency stop and control relay with Start and Stop function.

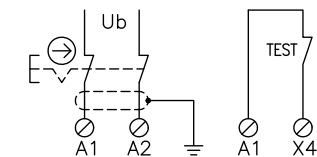

Emergency stop with dual connection direct to the supply voltage.

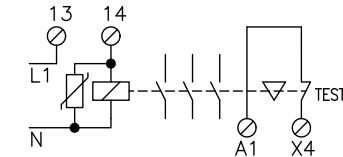

Controlled monitoring of external contactor, relay, valve or Jokab Safety's expansion relays.

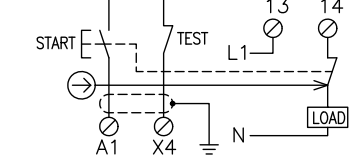

Monitoring to ensure that the On button is not stuck in pressed position. A short circuit over the closing contact is not monitored.

**\*Note: BT50 has additional power terminals A1 and A2.**

# BT51(T) Safety Relay/ Expansion Relay

## Single Channel Safety Relay

The BT51 is designed to connect safety devices, such as emergency stops, directly in the voltage supply circuit to the relay. Despite a maximum built-in width of only 22.5 mm, the relay is very powerful.

With 4 NO safety outputs, test input and complete internal supervising, the BT51 is quite unique. In addition you can order delayed outputs (BT51T).

In order for the safety outputs to close, the supply voltage, by means of an emergency stop button, must be connected to A1 and A2 and the test input closed. After actuation of the relay the test input can be opened again.

The test input is intended to supervise that contactors or valves have dropped/returned before a new start can be permitted. The test input can also be used for starting and the start button can be supervised (see Connection Example on next page).

## More Outputs

By connecting BT51 to a safety relay/PLC it is easy to increase the number of safe outputs. This means that an unlimited number of dangerous machine operations and functions can be stopped from one safety relay/PLC.

## Safety Level

The BT51 has a twin and supervised internal safety function. Power failure, internal component faults or external interference cannot result in dangerous functions.

Input via A1 only is not protected from short circuiting and therefore installation is critical for the safety level to be achieved. To achieve a higher safety level, a screened cable can be used and/or connection made to both A1 and A2 (see Technical Description on next page).

## Connection Examples

For examples of how our safety relays can solve various safety problems, see "Connection Examples" beginning on page 5:44.



## Applications

- Emergency Stops
- Interlocked Hatches
- Expansion of Safety Outputs

## Features

- Width 22.5 mm
- LED indication
- 4 NO relay outputs
- Test/reset input
- 24 VDC
- Single or dual channel
- BT51 - Additional power terminals
- Quick release connector blocks
- BT51T - 1 changeover relay with a double information output (Y14)
- BT51T - Delay times selectable from 0 to 1.5 s

## Regulations and Standards

The BT51 is designed and approved in accordance with appropriate directives and standards. See Technical Data.

## Approvals

TÜV Nord  

# BT51(T) Technical Data

Manufacturer	ABB AB/Jokab Safety, Sweden
Ordering information	see page 5:64
Color	Grey
Operational voltage	24 VDC + 15%/-25%
Power consumption	1.4 W/1.8 W
Relay outputs	4 NO
Maximum switching capacity	
Resistive load AC	6A/250 VAC/1500 VA
Inductive load AC	AC15 240VAC 2A
Resistive load DC	6A/24 VDC/150 W
Inductive load DC	DC13 24VDC 1A
Maximum res. load total switching capacity	12 A distributed on all contacts
Minimum load	10mA/10 V (if load on contact has not exceeded 100 mA)
Contact material	Ag + Au flash
Fuses output (external)	5A gL/gG
Conditional short-circuit current (1 kA)	6A gG
Maximum input wire res. at nom. voltage	200 Ohms
Response time at deactivation	<20 ms or delayed max 1500 ms (BT51T)

Terminals (max. screw torque 1 Nm)	
Single strand	2x1.5 mm <sup>2</sup>
Conductor with socket contact	2x1mm <sup>2</sup>
Mounting	35 mm DIN-rail
Protection class	
Enclosure/Terminals	IP 40/20 IEC 60529
Impulse withstand voltage	2.5kV
Pollution degree	2
Operating temperature range	-10°C to +55°C (with no icing or condensation)
Operating humidity range	35% to 85%
LED indication	Electrical Supply, Relay and X4
Weight	200 g
Performance (max.)	
Functional test	Category 4/PL e (EN ISO 13849-1:2008)
The relays must be cycled at least once a year	SIL 3 (EN 62061:2005) PFH <sub>d</sub> 1.63E-08
Conformity	2006/42/EC, 2006/95/EC 2004/108/EC EN 954-1:1996, EN 62061:2005 EN ISO 13849-1:2008

## BT51(T) Technical Description

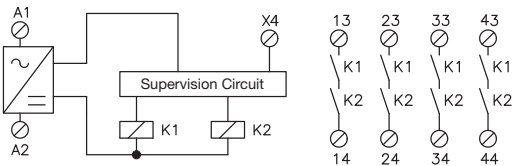

When supply voltage is connected to A1 and A2, relays K1 and K2 are activated. K1 and K2 drop if the supply voltage is disconnected. Both relays K1 and K2 must drop for them to be activated again. The test circuit, A1 - X4 can either be open or constantly closed.

The supervising circuit ensures that both K1 and K2 have dropped before they can be reactivated. The stop function complies with the requirement that a component fault or external interference cannot lead to a dangerous function.

The safety outputs consist of contacts from K1 and K2 connected internally in series across terminals 13-14, 23-24, 33-34 and 43-44. These contacts are used to cut the power to components which stop or prevent hazardous movements/functions. It is recommended that all

switched loads are adequately suppressed and/or fused in order to provide additional protection for the safety contacts.

### JSB51T Information Output

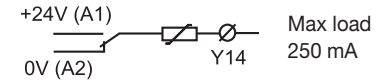

### JSBT51T Delay Times

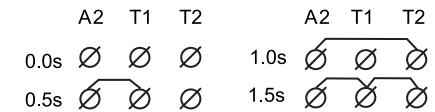

## BT51(T) Electrical Connections

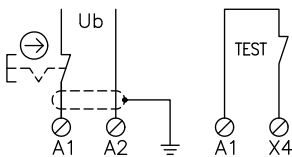

Emergency stop with reset when emergency button returns.

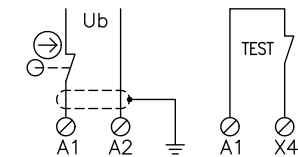

Hatch with automatic reset.

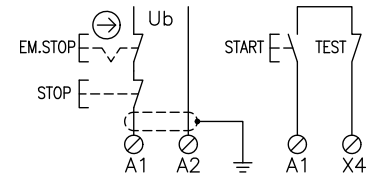

JSBT51 as emergency stop and control relay with Start and Stop function.

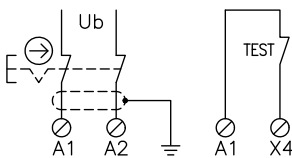

Emergency stop with dual connection direct to the supply voltage.

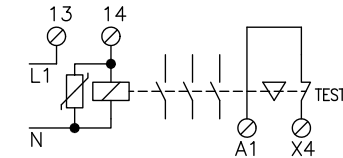

Controlled monitoring of external contactor, relay, valve or Jokab Safety's expansion relays.

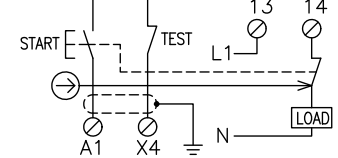

Monitoring to ensure that the On button is not stuck in pressed position. A short circuit over the closing contact is not monitored.

*\*Note: BT51 has additional power terminals A1 and A2.*

# JSBT5(T) Safety Relay

## Single Channel Safety Relay

The JSBT5 is designed to connect safety devices, such as emergency stops, directly in the voltage supply circuit to the relay. Despite a maximum built-in width of 22.5 mm the relay is very powerful.

With 3 NO safety outputs, 1 NC, test input and complete internal supervising, the JSBT5 is quite unique. In addition you can order delayed outputs (JSBT5T).

In order for the safety outputs to close, the supply voltage, e.g. by means of an emergency stop button, must be connected to A1 and A2 and the test input closed. After actuation of the relay the test input can be opened again.

The test input is intended to supervise that contactors or valves have dropped/returned before a new start can be permitted. The test input can also be used for starting and the start button can be supervised (see connection example on next page).

## Safety Level

The JSBT5 has a twin and supervised internal safety function. Power failure, internal component faults or external interference cannot result in dangerous functions.

Input via A1 only is not protected from short circuiting, and therefore installation is critical for the safety level to be achieved. To achieve a higher safety level a screened cable can be used and/or connection made to both A1 and A2.

## Connection Examples

For examples of how our safety relays can solve various safety problems, see “Connection Examples” beginning on page 5:44.



## Applications

- Emergency Stops
- Interlocked Hatches

## Features

- Width 22.5 mm
- LED indication
- 3 NO/1NC relay outputs
- Test/start input
- Supply 12VDC, 24 VDC/AC
- Single or dual channel
- (T) = delayed outputs 0.5 seconds

## Regulations and Standards

The JSBT5(T) is designed and approved in accordance with appropriate directives and standards. See Technical Data.

## Approvals

TÜV Nord  

# JSBT5(T) Technical Data

Manufacturer	ABB AB/Jokab Safety, Sweden
Ordering information	see page 5:64
Color	Grey
Operational voltage JSBT5 JSBT5T	24 VDC/AC + 15%–25%, 50–60 Hz 12 VDC, 24 VDC/AC + 15%–25%, 50 - 60 Hz
Power consumption	1 W/1.9 VA
Relay outputs	3 NO + 1 NC
Max. switching capacity Resistive load AC Inductive load AC Resistive load DC Inductive load DC	6A/250 VAC/1500 VA AC15 240VAC 2A 6A/24 VDC/150 W DC13 24VDC 1A
Maximum res. load total switching capacity	9A distributed on all contacts
Minimum load	10mA/10 V (if load on contact has not exceeded 100 mA)
Contact material	AgCuNi
Fuses output (external)	5A gL/gG
Conditional short-circuit current (1 kA)	6A gG
Maximum input wire res. at nom. voltage	200 Ohm

Response time at deactivation	<60 ms or delayed max 500 ms (JSBT5T)
Terminals (max. screw torque 1 Nm) Single strand Conductor with socket contact:	2x1.5 mm <sup>2</sup> 2x1mm <sup>2</sup>
Mounting	35 mm DIN-rail
Protection class Enclosure/Terminals	IP 40/20 IEC 60529
Impulse withstand voltage	2.5kV
Pollution degree	2
Operating temperature range	-10°C to +55°C (with no icing or condensation)
Operating humidity range	35% to 85%
Function indication	Electrical Supply
Weight	200 g
Performance (max.) Functional test The relays must be cycled at least once a year	Category 4/PL e (EN ISO 13849-1:2008) SIL 3 (EN 62061:2005) PFH <sub>d</sub> 1.22E-08
Conformity	2006/42/EC, 2006/95/EC 2004/108/EC EN 954-1:1996, EN 62061:2005 EN ISO 13849-1:2008

## JSBT5(T) Technical Description

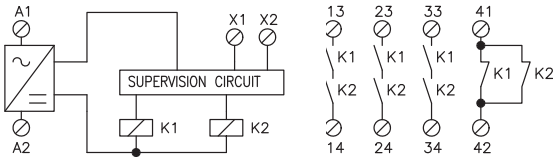

When supply voltage is connected to A1 and A2, relays K1 and K2 are activated. K1 and K2 drop if the supply voltage is disconnected. Both relays K1 and K2 must drop for them to be activated again. Another requirement is that the test

circuit, X1 - X2, must be closed for the outputs to be activated. Thereafter X1 - X2 can either be open or constantly closed.

The supervising circuit ensures that both K1 and K2 have dropped before they can be reactivated. The stop function complies with the requirement that a component fault or external interference cannot lead to a dangerous function.

The safety outputs consist of contacts from K1 and K2 connected internally in

series across terminals 13 - 14, 23 - 24, and 33 - 34. These contacts are used to cut the power to components which stop or prevent hazardous movements/functions. It is recommended that all switched loads are adequately suppressed and/or fused in order to provide additional protection for the safety contacts.

The NC output 41 - 42 should only be used for monitoring purposes e.g. indication lamp for emergency stop pressed.

## JSBT5(T) Electrical Connections

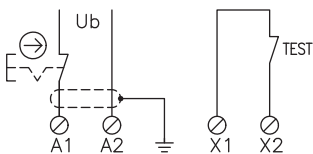

Emergency stop with reset when emergency button returns.

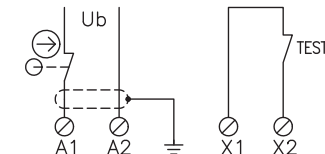

Hatch with automatic reset.

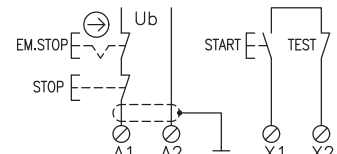

JSBT5(T) as emergency stop and control relay with Start and Stop function.

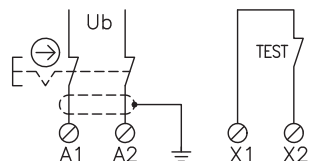

Emergency stop with dual connection direct to the supply voltage.

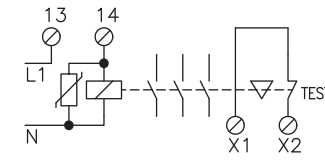

Controlled monitoring of external contactor, relay, valve or Jokab Safety's expansion relays.

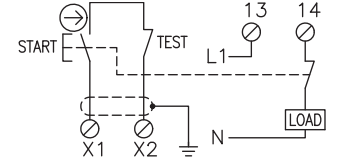

Monitoring to ensure that the On button is not stuck in pressed position. A short circuit over the closing contact is not monitored. The JSBR4 has been built in short circuit monitored resetting.

\*Note: BT51 has additional power terminals A1 and A2.

# JSHT1 A/B Safety Timer closes 2 independent relay outputs during a guaranteed maximum time when the inputs are opened

## Time Reset

Time reset can prevent unintentional reset of safety system when someone is still in the dangerous area of the machine. During a guaranteed maximum time, one or several PB's for reset must be activated. The reset buttons should be sited in such a way that operatives have a clear overview of the whole area which is guarded. Time reset is made by the combination of a safety relay and the timer relay JSHT1A/B.

## Time Bypassing

The JSHT1 can also be used for time bypass of light beams, for example, a forklift into a dangerous area.

## Operation

When the inputs open the output contacts close. The output contacts open when the inputs close or when the time period has expired. The time period is hardwire selectable on terminals T1, T2 and T3. The time given is the maximum time. One or two channel operation is also hardwire selectable.

## Connection Examples

For examples of how our safety relays can solve various safety problems, see "Connection Examples" beginning on page 5:44.



## Applications

- Time Reset
- Time Bypassing

## Features

- Hardwire time selection 5 - 40 s
- Selectable single or dual channel input
- Test input
- Width 45 mm
- LED indication for supply, inputs and outputs
- 1+1 NO relay outputs
- 24 VDC
- 24/48/115/230 VAC
- Quick release connector blocks

## Regulations and Standards

The JSHT1 A/B is designed and approved in accordance with appropriate directives and standards. See Technical Data.

## Approvals

TÜV Nord  

## JSHT1 A/B Technical Data

Manufacturer	ABB AB/Jokab Safety, Sweden
Ordering information	see page 5:64
Color	Grey
Power supply	24 VDC ± 15 %, 24/48/115/230 VAC ± 15 %, 50 - 60 Hz (AC versions JSHT1A only)
Power consumption	1.8 W/3.7 VA
Max input wire res. at nom voltage/channel	100/200 Ohm (1 Channel/ 2 Channel)
Response time at activation	<30ms
Response time at deactivation	< 15 ms
Selectable time (± 15 % at nom. V.)	JSHT1A: 5-10-15-20 sec JSHT1B: 5-15-30-40 sec
Relay outputs	2 x 1 NO
Maximum switching capacity	4A/250 VAC/1000 VA Resistive load AC Inductive load AC Resistive load DC Inductive load DC
Max. total switching capacity	8A distributed on all contacts
Minimum load	10mA/10 V (if load on contact has not exceeded 100 mA)
Contact material	AgCuNi
Fuses output (external)	3A gL/gG or 4A fast
Conditional short-circuit current (1 kA)	6A gG

Max input wire res. at nom. voltage	100 Ohm
Terminals (max. screw torque 1 Nm)	1 x 4 mm <sup>2</sup> , 2 x 1.5 mm <sup>2</sup>
Single strand Conductor with socket contact	1 x 2.5 mm <sup>2</sup> , 2 x 1 mm <sup>2</sup>
Mounting	35 mm DIN-rail
Protection class	IP20/IP40 IEC 60529
Enclosure/Terminals	
Impulse withstand voltage	2.5kV
Pollution degree	2
Operating temperature range	-10°C to +55°C (with no icing or condensation)
Operating humidity range	35% to 85%
LED indication	Electrical Supply, Inputs, Outputs
Weight	24 VDC: 330 g 24/48/115/230 VAC: 430 g
Performance (max.)	Category 4 / PL e
Functional test	(EN ISO 13849-1:2008)
The relays must be cycled at least once a year.	SIL 3 (EN 62061:2005) PFH <sub>d</sub> 4.42E-09
Conformity	2006/42/EC, 2006/95/EC 2004/108/EC EN 954-1:1996, EN 62061:2005 EN ISO 13849-1:2008

## JSHT1 A/B Technical Description

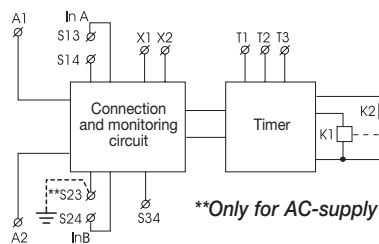

and the outputs close. K1 and K2 are activated for the hardwired selected time (set by connections on the terminals T1, T2 and T3). If there is a short circuit between the inputs or the inputs are closed again before the set time period has expired the outputs will open. In order to close the outputs again, both the inputs have to be closed and both internal relays K1 and K2 deactivated (controlled by the supervising circuit) and the inputs again opened.

By external hardware connections the JSHT1 can be made single or dual channel input. See figure below.

The electrical supply is connected across A1 and A2. The internal supervising circuit is activated directly when the supply is on. The inputs A and B must both be closed and then opened.

Thereafter K1 and K2 are activated

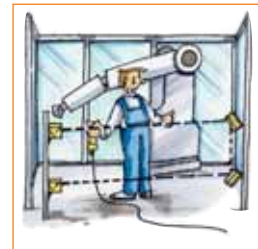

*Light beam being bypassed for a maximum pre-set time e.g. 5 sec. by the JSHT1 during entrance and exit with the JSHT4 Three Position Enabling device.*



*Time reset procedure. First push PB1, then exit dangerous area and close the door, then push PB2 (PB1 and PB2 must be pressed within the predetermined time period selected). After this procedure the machine can be safely restarted.*

## JSHT1 A/B Electrical Connections

Connection for single channel input.

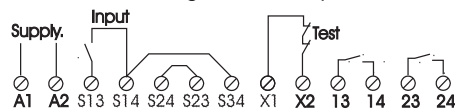

Selection of time by hardwire links.

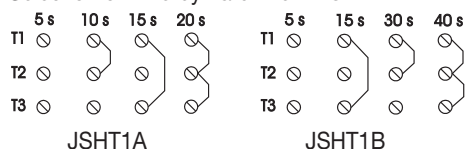

Connection for dual channel input.

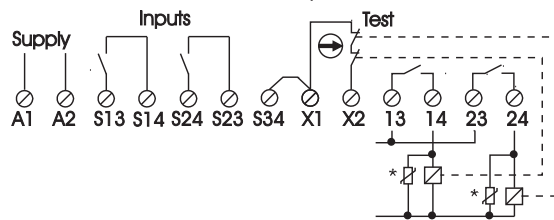

*\* It is recommended that all switched loads are adequately suppressed and/or fused in order to provide additional protection for the safety contacts.*

*In the figure the monitoring of two contactors in the test input is shown.*

# JSHT2 A/B/C Safety Timer closes 2 independent relay outputs during a guaranteed maximum time when the inputs are closed

## Time Bypassing

Sensors detect the autocarrier and are connected to the JSHT2 which supervises the sensors and bypasses the light beam for a maximum predetermined time.

## Inching

Inching applications require safety outputs to be closed for a predetermined maximum period of time, allowing the machine to move only a short distance each time the inching control is activated. For each new motion the inching control, e.g. PB or pedal must be released and activated again.

## Operation

When the inputs close the output contacts close. The output contacts open when the input opens or when the time period has expired. The time is hardwire selectable on the terminals T1, T2 and T3. The time given is the maximum time. Single or dual channel operation is also hardwire selectable.

## Connection Examples

For examples of how our safety relays can solve various safety problems, see "Connection Examples" beginning on page 5:44.

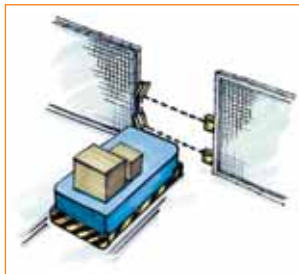

Light beam being bypassed only for the time it takes the autocarrier to pass.



Shaft only turns a small amount each time the PB is pressed.



## Applications

- Time Bypassing
- Inching

## Features

- Hardwire time selection 0.2 - 40 s
- Selectable single or dual channel input
- Test input
- Width 45 mm
- LED indication for supply, inputs and outputs
- 1+1 NO relay outputs
- 24 VDC
- 24/48/115/230 VAC
- Quick release connector blocks

## Regulations and Standards

The JSHT2 A/B/C is designed and approved in accordance with appropriate directives and standards. See Technical Data.

## Approvals

TÜV Nord  



## JSHT2 A/B/C Technical Data

Manufacturer	ABB AB/Jokab Safety, Sweden
Ordering information	see page 5:65
Color	Grey
Power supply	24 VDC ± 15 % 24/48/115/230 VAC ± 15 %, 50 - 60 Hz
Power consumption	1.8 W/3.8 VA
Max input wire res. at nom voltage/channel	100/200 Ohm (1 Channel/ 2 Channel)
Response time at activation	< 30 ms
Response time at deactivation	< 15 ms
Selectable time (± 15 % at nom. V.)	JSHT2A: 0.2 - 0.5 - 0.7 - 1.0 sec JSHT2B: 5 - 10 - 15 - 20 sec JSHT2C: 5 - 15 - 30 - 40 sec
Relay outputs	2 x 1 NO
Maximum switching capacity	Resistive load AC: 4A/250 VAC/1000 VA Inductive load AC: AC15 250VAC 3A Resistive load DC: 4A/24 VDC/100 W Inductive load DC: DC13 24VDC 2A
Maximum total switching capacity	8A distributed on all contacts
Minimum load	10mA/10 V (if load on contact has not exceeded 100 mA)
Contact material	AgCuNi
Fuses output (external)	3A gL/gG or 4A fast
Maximum input wire res. at nom. voltage	100 Ohm
Terminals (max. screw torque 1 Nm)	Single strand: 1 x 4 mm <sup>2</sup> or 2 x 1.5 mm <sup>2</sup> Conductor with socket contact: 1 x 2.5 mm <sup>2</sup> or 2 x 1 mm <sup>2</sup>
Mounting	35 mm DIN-rail
Protection class	IP 20/IP 40 IEC 60529

Impulse withstand voltage	2.5kV
Pollution degree	2
Operating temperature range	-10°C to +55°C (with no icing or condensation)
Operating humidity range	35% to 85%
LED indication	Electrical Supply, Inputs, Outputs
Weight	24 VDC: 310 g 24/48/115/230 VAC: 410 g.
Performance (max.) Functional test The relays must be cycled at least once a year	Safety Category 4/PL e (EN ISO 13849-1:2008) SIL 3 (EN 62061:2005) PFH <sub>d</sub> 4.42E-09
Conformity	2006/42/EC, 2006/95/EC 2004/108/EC EN 954-1:1996, EN 62061:2005 EN ISO 13849-1:2008

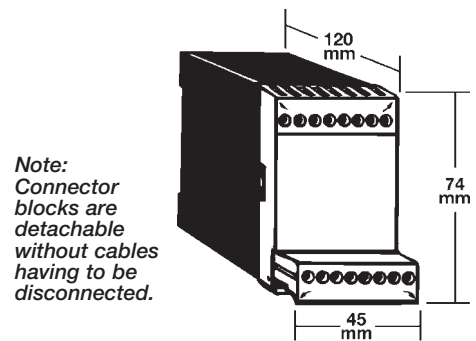

## JSHT2 A/B/C Technical Description

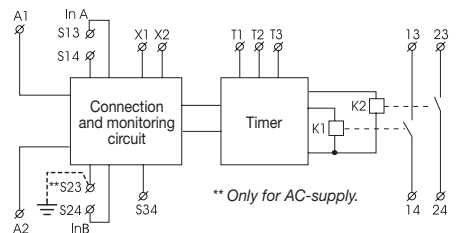

The electrical supply is connected across A1 and A2. The internal supervising circuit is activated directly when the supply is on. The inputs A and B must both be opened and then closed. Thereafter K1 and K2 are activated and the outputs close. K1 and K2 are activated for the hardwired selected time (set by connections on the terminals T1, T2 and T3) If there is a short circuit between the inputs or the inputs are

opened again before the set time period has expired the outputs will open. In order to close the outputs again both the inputs have to be opened and both internal relays K1 and K2 deactivated (controlled by the supervising circuit) and the inputs again closed. By external hardware connections the JSHT2 can be made single or dual channel input. See figure below.

## JSHT2 A/B/C Electrical Connections

Connection for single channel input.

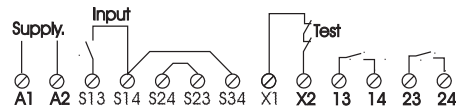

Connection for dual channel input.

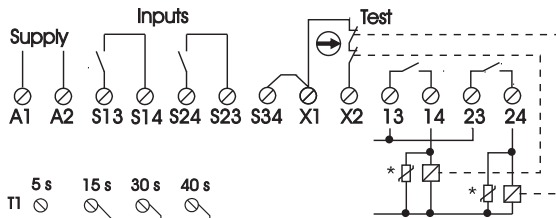

Selection of time by hardwire links.

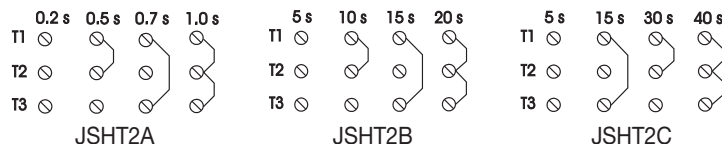

\* It is recommended that all switched loads are adequately suppressed and/or fused in order to provide additional protection for the safety contacts.

In the figure the monitoring of two contactors in the test input is shown.

# E1T Expansion Relay

## More Outputs

By connecting expansion relays to a safety relay it is easy to increase the number of safe outputs. This means that an unlimited number of dangerous machine operations and functions can be stopped from one safety relay/PLC.

## Safe Soft Stop

When a gate is opened a program stop is first given to the machine's PLC/servo which brakes the dangerous operations in a soft and controlled way. The safety outputs then break the power to the motors, that is, when the machine has already stopped. Normally between 0.5 and 1 second is needed to brake a dangerous machine operation softly. Soft stop ensures many advantages:

- The machine lasts longer.
- Parts being processed are not damaged.
- Restart from stopped position is enabled and simplified.

A safe soft stop is achieved by means of a safety relay which gives the program stop, and an expansion relay, E1T, which gives safe delayed stop signals. See chapter "Connection Examples". The drop time delay on a E1T can be from 0 to 3 seconds depending on the model. By connecting several E1Ts in series even longer times can be achieved.

## Safety Level

The E1T has twin stop functions, that is, two relays with mechanically operated contacts. A monitored stop function is achieved by connecting the test output (terminals X1 and X2) to the test or reset input on the safety relay which is being expanded.

One condition for a safe delayed stop is that the delay time cannot increase in the event of a fault. The E1T complies with this requirement.

## When are delayed safe stops used?

Delayed safety stop signals can be used for emergency stops according to EN ISO 13850:2008 § 4.1.4. Stop category 1 and NFPA 79, i.e. a controlled stop with power to the actuator(s) available to achieve the stop and then removal of power when stop is achieved.

Stop category 1 may also be permitted when it is not possible to gain physical access to the machine before the safe stop is affected e.g:

- Gates, access time is normally over 1 sec.
- Covers and gates which are locked until dangerous operations and functions have been stopped.
- Long distances between a safety device and a dangerous machine function.



## Applications

- More Safety Outputs
- Delayed Safety Outputs
- Output Contact Indication

## Features

- Width 22.5 mm
- LED indication of output
- 4 NO relay outputs
- 24 VDC
- Single or dual channel operation option
- Quick release connector blocks

## Connection Examples

For examples of how our safety relays can solve various safety problems, see "Connection Examples" beginning on page 5:44.

## Regulations and Standards

The E1T is designed and approved in accordance with appropriate directives and standards. See Technical Data.

## Approvals

TÜV Nord  

## E1T Technical Data

Manufacturer	ABB AB/Jokab Safety, Sweden	Mounting	35 mm DIN-rail
Ordering information	see page 5:65	Protection class	
Color	Grey	Enclosure	IP 40 IEC 60529
Operational voltage	24 VDC ± 15%	Terminals	IP 20 IEC 60529
Power consumption	1.5 W	Impulse withstand voltage	2.5kV
Relay outputs	4 NO	Pollution degree	2
Maximum switching capacity		Operating temperature range	-10°C – +55°C (with no icing or condensation)
Resistive load AC	6A/250VAC/1500VA	Operating humidity range	35% to 85%
Inductive load AC	AC15 240VAC 2A	LED indication	Output status
Resistive load DC	6A/24VDC/150W	Weight	220 g
Inductive load DC	DC13 24VDC 1A	Performance (max.)	Category 4/PL e (EN ISO 13849-1:2008)
Max. total switching capacity	12A distributed on all contacts	Functional test	SIL 3 (EN 62061:2005)
Minimum switching load	10 mA/10 V (if load on contact has not exceeded 100 mA)	The relays must be cycled at least once a year	PFH <sub>d</sub> 1.55E-08
Contact material	Ag + Au flash	Conformity	2006/42/EC, 2006/95/EC 2004/108/EC EN 954-1:1996, EN 62061:2005 EN ISO 13849-1:2008
Fuses output (external)	5A gL/gG		
Conditional short-circuit current (1 kA)	6A gG		
Maximum external resistance at nominal voltage	150 Ohm (S14, S24)		
Response time at deactivation (input-output)	< 0,020 s, 0,5 s, 1 s, 1,5 s, 2 s, 3 s, ± 20%		
Response time at activation (input-output)	<30 ms		
Terminals (max. screw torque 1 Nm)			
Single strand	1x4 mm <sup>2</sup> /2x1.5 mm <sup>2</sup>		
Conductor with socket contact	1x2.5 mm <sup>2</sup> /2x1 mm <sup>2</sup>		

**Note:**  
Connector blocks are detachable without cables having to be disconnected.

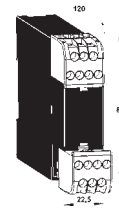

## E1T Technical Description

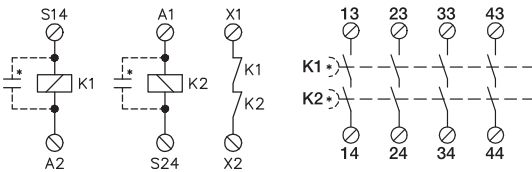

operation - see below.) When the inputs S14 and S24 close, relays K1 and K2 are activated. A stop signal is given, K1 and K2 drop, if the inputs are opened or during power failure. K1 and K2 drop either directly or after a delay\* (if incorporated). Delay time of module is fixed and shown on front panel of device. The delay circuit is arranged so that the design time cannot be exceeded.

X1 and X2 to the test or reset input on the safety relay which is expanded (see below). K1 and K2 are mechanically operated relays, therefore, if one of the output contacts should stick closed then the relay's contact in X1-X2 cannot be closed thus preventing a new ready signal being given to the safety relay.

The E1T has to be connected to a safety relay in order to fulfill the necessary safety requirements (see connection examples below). The safety relay controls and monitors the E1T. (The E1T can be connected for single or dual channel

To check that both the relays K1 and K2 drop during a stop signal they must be monitored. This is achieved by connecting

Inductive loads should be equipped with an arc suppressor to protect the output contacts.

Diodes are the best arc suppressors but will increase the switch off time of the load.

## E1T Electrical Connections

Single channel expansion of outputs for a safety relay connected to an emergency stop.

Dual channel expansion with delayed safety outputs for a safety relay monitoring a gate.

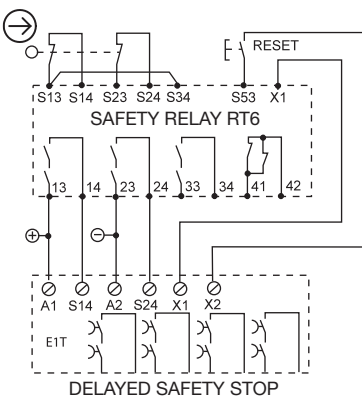
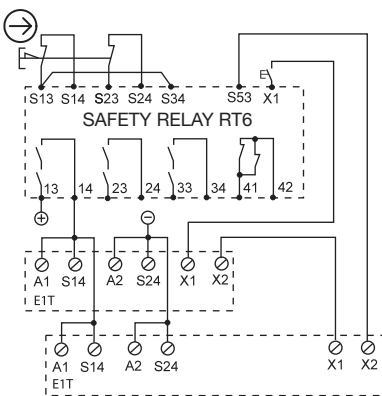

# JSR1T Expansion Relay

## More Outputs

By connecting expansion relays to a safety relay it is easy to increase the number of safe outputs. This means that an unlimited number of dangerous machine operations and functions can be stopped from one safety relay/PLC.

## Safe Soft Stop

When a gate is opened, a program stop is first given to the machine's PLC/servo which brakes the dangerous operations in a soft and controlled way. The safety outputs then break the power to the motors, that is, when the machine has already stopped. Normally between 0.5 and 1 second is needed to brake a dangerous machine operation softly. Soft stop ensures many advantages:

- The machine lasts longer.
- Parts being processed are not damaged.
- Restart from stopped position is enabled and simplified.

A safe soft stop is achieved by means of a safety relay which gives the program stop, and an expansion relay, JSR1T, which gives safe delayed stop signals. See chapter "Connection Examples". The drop time delay on a JSR1T can be from 0 to 10 seconds depending on the model. By connecting several JSR1Ts in series even longer times can be achieved.

## Safety Level

The JSR1T has twin stop functions, that is, two relays with mechanically operated contacts. A monitored stop function is achieved by connecting the test output (terminals X1 and X2) to the test or reset input on the safety relay which is being expanded.

One condition for a safe delayed stop is that the delay time cannot increase in the event of a fault. The JSR1T complies with this requirement.

## When are delayed safe stops used?

Delayed safety stop signals can be used for emergency stops according to EN ISO 13850:2008 § 4.1.4. Stop category 1 and NFPA 79, i.e. a controlled stop with power to the actuator(s) available to achieve the stop and then removal of power when stop is achieved.

Stop category 1 may also be permitted when it is not possible to gain physical access to the machine before the safe stop is affected e.g:

- Gates, access time is normally over 1 sec.
- Covers and gates which are locked until dangerous operations and functions have been stopped.
- Long distances between a safety device and a dangerous machine function.



## Expansion Relay with

- More Safety Outputs
- Delayed Safety Outputs
- Information Output

## Features

- Width 45 mm
- LED indication of output
- 4 NO/1 NC relay outputs
- 24 VDC
- Single and dual channel
- Quick release connector blocks

## Connection Examples

For examples of how our safety relays can solve various safety problems, see "Connection Examples" beginning on page 5:44.

## Regulations and Standards

The JSR1T is designed and approved in accordance with appropriate directives and standards. See Technical Data.

## Approvals

TÜV Nord  

# JSR1T Technical Data

Manufacturer	ABB AB/Jokab Safety, Sweden
Ordering information	see page 5:66
Color	Grey
Power supply	24 VDC ±15%
Power consumption	1.2 W
Relay outputs	4 NO + 1 NC
Max. switching capacity	
Resistive load AC	6A/250 VAC/1500 VA
Inductive load AC	AC15 240VAC 2A
Resistive load DC	6A/24 VDC/150 W
Inductive load DC	DC13 24VDC 1A
Max. total switching capacity	16A distributed on all contacts
Minimum load	10mA/10 V (if load on contact has not exceeded 100 mA)
Contact material	Ag + Au flash
Fuses output (external)	5A gL/gG
Conditional short-circuit current (1 kA)	6A gG
Maximum input wire res. at nom. voltage	150 Ohm (S14, S24)
Response time at deactivation (input-output)	< 0,020 s, 0,5 s, 1 s, 1,5 s, 2 s, 3 s, 5 s, 8 s, 10 s ± 20 %
Terminals (max. screw torque 1 Nm)	
Single strand	1 x 2.5 mm <sup>2</sup> /2 x 1mm <sup>2</sup>
Conductor with socket contact	1 x 4 mm <sup>2</sup> /2 x 1.5 mm <sup>2</sup>
Mounting	35 mm DIN-rail

Impulse withstand voltage	2.5kV
Protection class	
Enclosure/Terminals	IP 40/20 IEC 60529
Pollution degree	2
Operating temperature range	-10°C to +55°C (with no icing or condensation)
Operating humidity range	35% to 85%
LED indication	Output Relay Supplies
Weight	280 g
Performance (max.)	Category 4/PL e
Functional test	(EN ISO 13849-1:2008)
The relays must be cycled at least once a year	SIL 3 (EN 62061:2005) PFH <sub>d</sub> 1.55E-08
Conformity	2006/42/EC, 2006/95/EC 2004/108/EC EN 954-1:1996, EN 62061:2005 EN ISO 13849-1:2008

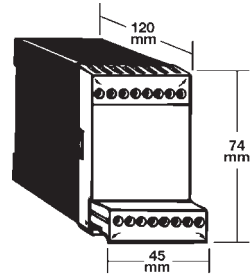

*Note:*  
Connector blocks are detachable without cables having to be disconnected.

## JSR1T Technical Description

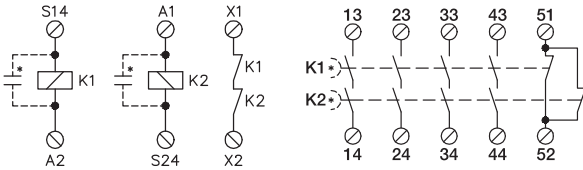

The JSR1T has to be connected to a safety relay in order to fulfill the necessary safety requirements (see connection examples below). The safety relay controls and monitors the JSR1T. (The JSR1T can be connected for single or dual channel

operation - see below.)  
When the inputs S14 and S24 close, relays K1 and K2 are activated. A stop signal is given, if the inputs are opened or during power failure. K1 and K2 drop either directly or after a delay\* (if incorporated). Delay time of module is fixed and shown on front panel of device. The delay circuit is arranged so that the design time cannot be exceeded.

To check that both the relays K1 and K2 drop during a stop signal they must

be monitored.

This is achieved by connecting X1 and X2 to the test or reset input on the safety relay which is expanded (see below). K1 and K2 are mechanically operated relays, therefore, if one of the output contacts should stick closed then the relay's contact in X1-X2 cannot be closed thus preventing a new ready signal being given to the safety relay.

Inductive loads should be equipped with an arch suppressor to protect the output contacts.

Diodes are the best arc suppressors but will increase the switch of time of the load.

## JSR1T Electrical Connections

Expansion of outputs for safety relay connected to emergency stop with automatic reset.

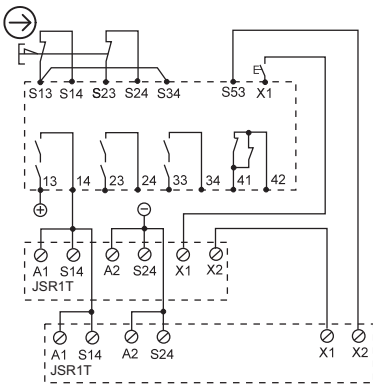

Dual channel expansion with delayed safety outputs for a safety relay monitoring a gate.

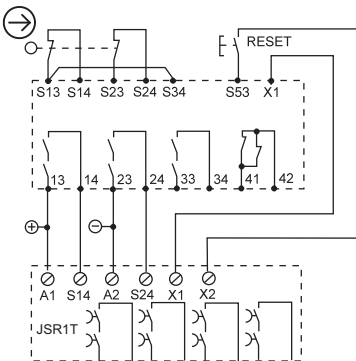

# JSR2A Expansion Relay

## More Outputs

The JSR2A expansion relay is used to provide increased switching capacity and number of safety outputs to a safety relay. This means that an unlimited number of dangerous machine operations and functions can be stopped from one safety relay/PLC.

## Greater Current Switching Capacity

The JSR2A expansion relay enables switching of up to 10 amps (AC/DC) per output contact.

## Safety Level

The JSR2A has twin stop functions, that is, two relays with mechanically positively guided contacts. A monitored stop function is achieved by connecting the test output (terminals X1 and X2) to the test or reset input on the safety relay which is to be expanded.

## Connection Examples

For examples of how our safety relays can solve various safety problems, see “Connection Examples” beginning on page 5:44.



## Expansion Relay with

- More Safety Outputs
- Greater Current Switching Capacity
- Output Contact Indication

## Features

- Switching up to 10A/250V/output
- Width 45 mm
- LED function indication
- 4 NO/1 NC relay outputs
- 5 supply versions
- 24 VDC/VAC
- 48, 115, 230 VAC
- Quick release connector blocks

## Regulations and Standards

The JSR2A is designed and approved in accordance with appropriate directives and standards. See Technical Data.

## Approvals

TÜV Nord  

# JSR2A Technical Data

Manufacturer	ABB AB/Jokab Safety, Sweden
Ordering information	see page 5:67
Color	Grey
Supply A1 - A2	24 VDC/AC, 48, 115, 230 VAC + 15%, 50-60 Hz
Power consumption	2.7W/2.4-4 VA
Relay outputs	4 NO + 1 NC
Maximum switching capacity	8A/230 VAC/1840 VA
Resistive load AC	10A/115VAC/48VAC/24VAC/1840 VA
Inductive load AC	AC15 230VAC 4A (NO-contact) 1.5A (NC-contact)
Resistive load DC	8A/24 VDC/192 W
Inductive load DC	DC13 24VDC 1.2A (NO/NC-contact)
Max. total switching capacity	16A distributed on all contacts
Min. load	10mA/10V/100mW (if load on contact has not exceeded 100 mA)
Contact material	AgSnO <sub>2</sub> + Au flash
Fuses output (external)	6A gL ( 8A fast if short-circuit current >500A )
Conditional short-circuit current (1 kA)	10A gG
Max. input wire res. at nom. voltage	24 VDC/VAC: 100 Ohm 48/115/230 VAC: 200 Ohm
Mechanical operational life	>107 operations
Response time at deactivation (input-output)	<25 ms
activation (input-output)	<15 ms
Terminals (removable)	
Max. screw torque	1 Nm
Connection area (max.)	
Single strand	1 x 4 mm <sup>2</sup> or 2 x 1.5 mm <sup>2</sup> /12AWG
Conductor with socket contact	1 x 2.5 mm <sup>2</sup> or 2 x 1 mm <sup>2</sup>

Mounting	35 mm DIN-rail
Protection class	
Enclosure	IP 40 IEC 60529
Terminals	IP 20 IEC 60529
LED indication	
On	●
1	●
2	●
Impulse withstand voltage	2.5kV
Pollution degree	2
Operating temperature range	-10°C to +55°C (with no icing or condensation)
Operating humidity range	35% to 85%
Weight	313 g
Performance (max.)	Category 4/PL e (EN ISO 13849-1:2008)
Functional test	SIL 3 (EN 62061:2005)
The relays must be cycled at least once a year	PFH <sub>d</sub> 1.55E-08
Conformity	2006/42/EC, 2006/95/EC 2004/108/EC EN 954-1:1996, EN 62061:2005 EN ISO 13849-1:2008

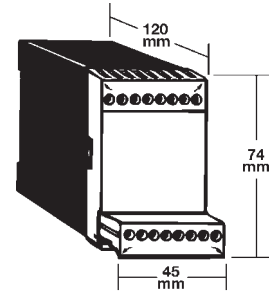

Connector blocks are detachable (without cables having to be disconnected)

## JSR2A Technical Description

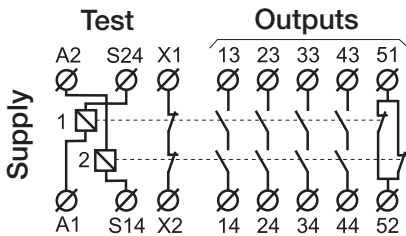

The JSR2A has to be connected to a suitable safety relay in order to fulfill the necessary safety requirements (see Connection Examples). The safety relay controls and monitors the JSR2A unit. (The JSR2A can be connected for single or dual channel operation — see electrical connection diagrams below.) When the inputs to S14 and S24 close, internal relays K1 and K2 are activated. A stop signal is given, K1 and K2 drop, if the inputs are opened or during power failure.

To check that both the K1 and K2 relays drop during a stop signal they must be monitored. This is achieved by connecting X1 and X2 to the test or reset input on the safety relay which is expanded. K1 and K2 have mechanically positively guided contacts, therefore if one of the output contacts should stick closed then the relay's contact in X1-X2 cannot be closed thus preventing a new ready signal being given to the safety relay.

## JSR2A Electrical Connections

One channel expansion of RT6 with JSR2A connected for manual reset.

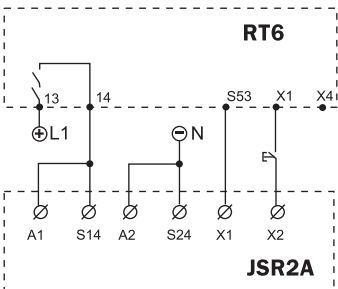

Dual channel expansion of RT6 with JSR2A connected for automatic reset.

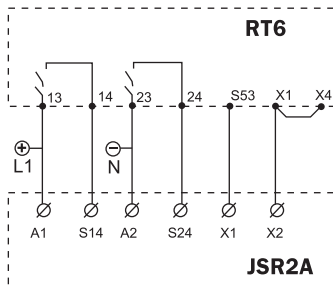

# JSR3T Expansion Relay

## Delayed Outputs

By connecting the JSR3T expansion relay to a compatible safety relay/PLC it is easy to obtain safe “delayed” outputs.

The JSR3T provides the system designer with the facility to hardwire selected time delays in steps between 0.5 and 10 seconds.

## Use of Delayed Outputs

There are many applications where delayed outputs are necessary and permissible. For example delayed stop signals can be used for emergency stops according to EN ISO 13850:2008 § 4.1.4 Stop Category 1 and NFPA 79 (a controlled stop with power to the machine actuator(s) available to achieve the stop and then removal of power when stop is achieved). Stop Category 1 may also be permitted when it is not possible to gain physical access to the machine before the safe stop is effected, e.g. by:

- Covers and Gates which are locked until dangerous operations and functions have been stopped.
- Long distances between a safety device and dangerous machine functions.

Using this technique of stopping a machine provides many advantages i.e.:

- Machines last longer as they are not subjected to excessive loading, etc. when requested to stop.
- Parts being processed are not damaged.
- Restarting machines from stopped position is simplified.

A safe “soft” stop is achieved by means of a safety relay giving a programmed stop to the machine control system, e.g. when a gate is opened or emergency stop is activated. The output of the safety relay is used to provide both a stop signal to the machine control system, i.e. via a PLC which applies the necessary braking/stopping of the machine in a controlled way, and to switch a delayed expansion relay, e.g. JSR3T. The delayed safety outputs of the JSR3T expansion relay are then used to control the safe disconnection of the power to the actuators/motors, etc. of the machine.

## Safety Level

The JSR3T has twin stop functions, using two positively guided contact relays. In order to achieve the level of monitoring required the JSR3T must be used with a suitable safety relay, e.g. JSBR4, RT6, RT9, etc. The JSR3T test output (terminals X1 and X2) must be connected to the test input of the safety relay being expanded. (See connection examples.)

The JSR3T provides delay times that even in the event of an internal fault condition complies with the requirement that the set delay cannot increase in time.



## Expansion Relay with Delay for

- Hardwire Selection of Delay Time
- Delayed Safety Outputs

## Features

- Hardwire selectable delay 0.5 - 10.0 seconds by hardwire links and time trim potentiometer
- Width 22.5 mm
- Output indication
- 2 x 1 NO relay outputs
- 24 VDC/VAC

## Connection Examples

For examples of how our safety relays can solve various safety problems, see “Connection Examples” beginning on page 5:44.

## Regulations and Standards

The JSR3T is designed and approved in accordance with appropriate directives and standards. See Technical Data.

## Approvals

TÜV Nord  



# JSR3T Technical Data

Manufacturer	ABB AB/Jokab Safety, Sweden
Ordering information	see page 5:67
Color	Grey
Power supply	24 VAC/DC, 50 - 60 Hz
Power consumption	1.3 VA/W
Relay outputs	2 x 1 NO (see connection examples)
Maximum switching capacity	
Resistive load AC	4A/250VAC/1000 VA
Inductive load AC	AC15 240VAC 3A
Resistive load DC	4A/24 VDC/100 W
Inductive load DC	DC13 24VDC 2A
Maximum res. load total switching capacity	6A distributed on all contacts
Minimum load	10mA/10V (if load on contact has not exceeded 100 mA)
Contact material	AgNi
Fuses output (external)	3A gL/gG or 4A fast
Conditional short-circuit current (1 kA)	6A gG
Max input wire res. at nom. voltage	100 Ohm
Response time at activation	<20ms
Response time at deactivation	<0.5 - 10.0 sec. at nom. voltage. Selected delay can be lowered by up to approx. 30% by means of preset potentiometer on front panel
Terminals (max. screw torque 1 Nm)	Single strand: 2x1.5 mm <sup>2</sup> Conductor with socket contact: 2x1mm <sup>2</sup>

Mounting	35 mm DIN-rail
Protection class	
Enclosure/Terminals	IP 40/20 IEC 60529
Impulse withstand voltage	2.5kV
Pollution degree	2
Operating temperature range	-10°C to +55°C (with no icing or condensation)
Operating humidity range	35% to 85%
LED indication	Outputs
Weight	158 g
Performance (max.)	Category 4/PL e (EN ISO 13849-1:2008)
Functional test	SIL 3 (EN 62061:2005)
The relays must be cycled at least once a year.	PFH <sub>d</sub> 3.67E-09
Conformity	2006/42/EC, 2006/95/EC 2004/108/EC EN 954-1:1996, EN 62061:2005 EN ISO 13849-1:2008

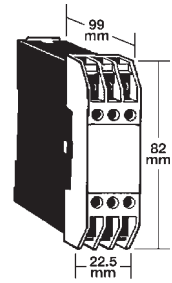

## JSR3T Technical Description

When supply voltage is connected to A1 and A2, relays K1 and K2 are activated. When the supply voltage is removed, relays K1 and K2 remain energized for a time period determined by the hardwire link configuration chosen (set by connecting links on the terminals Y1, Y2, Y3 and Y4) and the setting of the Time Trim potentiometer.

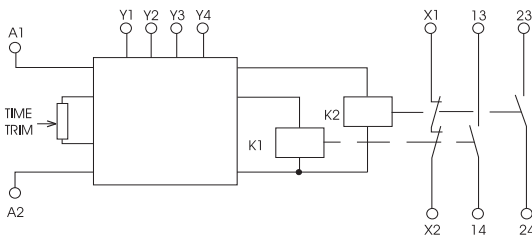

**Note 1:** Max. time set by hardwire links can only be reduced (up to approx. 40% reduction) by Time Trim potentiometer.

**Note 2:** Both the output contacts of K1 and K2 (13-14 and 23-24) must be used. Output contacts must be either connected in series (forming one safety output) or used in parallel circuits in order to obtain necessary redundancy.

## JSR3T Electrical Connections

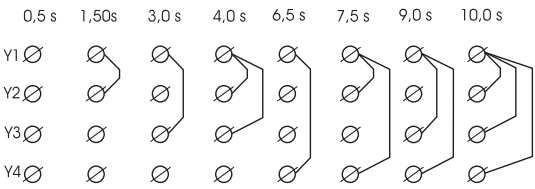
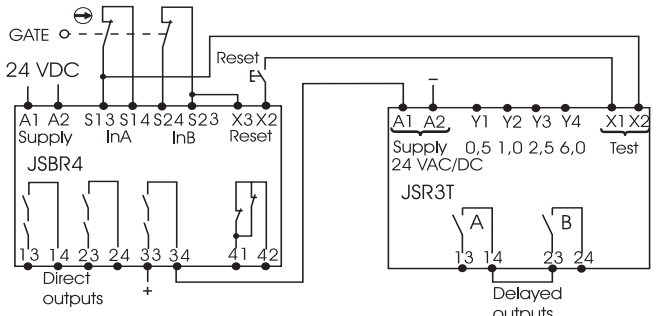
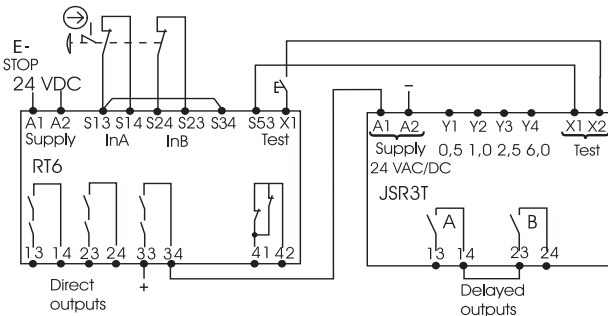

It is recommended that all switched loads are adequately suppressed and/or fused in order to provide additional protection for the safety contacts.

Selection of time delay by hardwire links (Y1, Y2, Y3 and Y4). Selected delay can be lowered by up to approximately 30% by means of preset potentiometer on front panel.

# Connection Examples Contents

## General Drawings - Relays

<b>HA5400A</b>	Connection Examples JSBR4.....	5:45
<b>HA6400A</b>	Connection Examples JSBT4.....	5:45
<b>HA6500B</b>	Connection Examples BT50.....	5:46
<b>HA6501B</b>	Connection Examples BT50T.....	5:46
<b>HA6500C</b>	Connection Examples BT51.....	5:47
<b>HA6501C</b>	Connection Examples BT51T.....	5:47
<b>HA7100A</b>	Connection Examples JSBRT11.....	5:48
<b>HA7600A</b>	Connection Examples RT6.....	5:48
<b>HA7600B</b>	Safety Mat, Emergency Stop, and Hatch with RT6.....	5:49
<b>HA7672A</b>	Enabling Device JSHD4-EX with RT6.....	5:49
<b>HA7700A</b>	Connection Examples RT7.....	5:50
<b>HA7900A</b>	Connection Examples RT9.....	5:50

## Examples with Safety Light Beam

<b>HE3811B</b>	Safety Light Beam Spot with Time-Limited Reset.....	5:51
<b>HE3824C</b>	Light Beam with Time-Limited Bypass 0.2-40 s.....	5:51
<b>HG7636B</b>	Focus Light Grid/Curtain with Three-Position Device.....	5:52

## Examples with Interlocked Doors/Switches

<b>HG7611A</b>	Interlocked Door with RT6 and Pre-Reset.....	5:52
<b>HG7636A</b>	Interlocked Door with Three-Position Device.....	5:53
<b>HG7646A</b>	Interlocked Door with Three-Position Device and Time-Limited Entrance/ Exit.....	5:53
<b>HG7654A</b>	Interlocked Door with RT6 and Output Expansion JSR1T.....	5:54

## Examples with Interlocked Doors/Switches

<b>HG7658A</b>	Interlocked Door with RT6 and Output Expansion JSR2A.....	5:54
<b>HG7673A</b>	Safety Interlock Switch JSNY8 with RT6.....	5:55
<b>HA6500A</b>	Safety Interlock Switch JSBT5.....	5:55
<b>HG7674A</b>	Safety Interlock Switch JSNY9M/MLA with RT6.....	5:56
<b>HG7674B</b>	Safety Interlock Switch JSNY9S/SLA with RT6.....	5:56

## Additional Examples

<b>HH0000C</b>	Three-Position Device JSHD4 with Various Safety Modules.....	5:57
<b>HI8552A</b>	Connection Example JSHT2 Intermittent Running.....	5:57

## Safety Mats and Contact Strips

<b>HK7600A</b>	Safety Mat/Contact Strip with RT6.....	5:58
----------------	----------------------------------------	------

## Hatches

<b>HL7600B</b>	Several JSNY7 Connected to one RT6 with Unique Indication.....	5:58
----------------	-------------------------------------------------------------------	------

## Magnetic Switches

<b>HM0000A</b>	Magnetic Switch JSNY7 with Various Safety Modules.....	5:59
----------------	-----------------------------------------------------------	------

## Output Examples

<b>HN7660A</b>	Delayed Outputs RT6 with Output Expansion JSR3T/RT7.....	5:59
----------------	-------------------------------------------------------------	------

## Common Examples

<b>HP7600A</b>	Machine Control - Isolation of PLC Inputs and Outputs.....	5:60
<b>HP7600B</b>	Machine Control - Isolation of PLC Outputs.....	5:60

## Two-Hand Devices

<b>HT5400A</b>	Two-Hand Device with JSBR4.....	5:61
----------------	---------------------------------	------

# General Drawing

## HA5400A Connection Example JSBR4

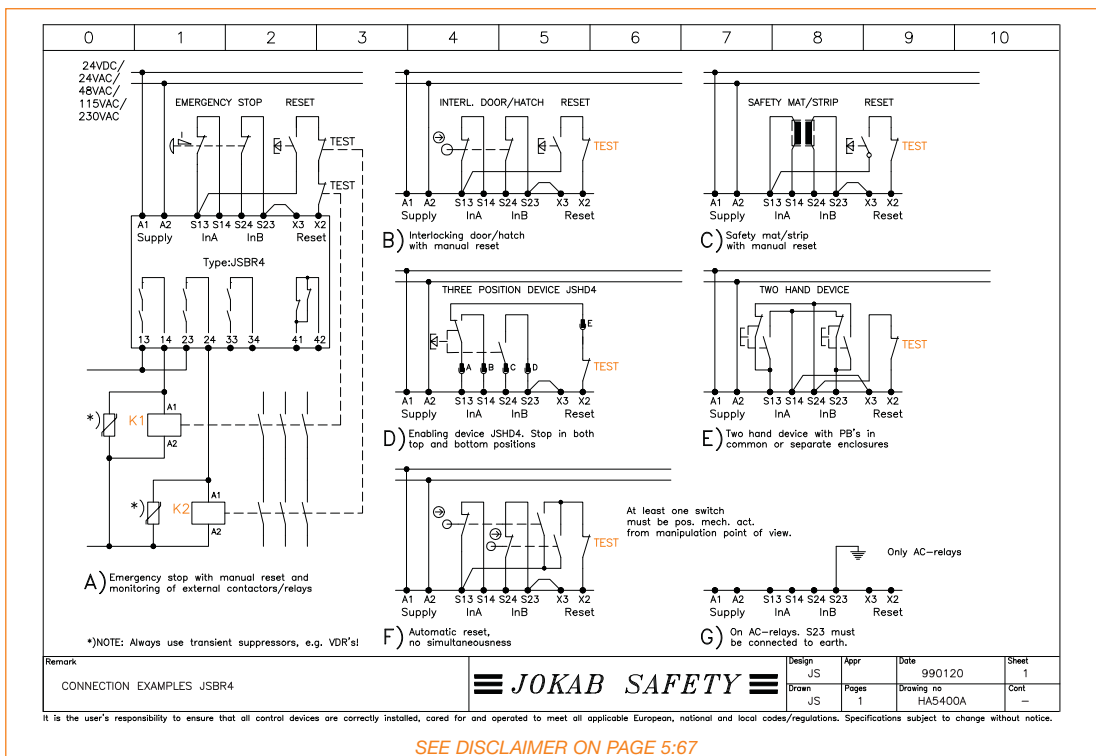

# General Drawing

## HA6400A Connection Example JSBT4

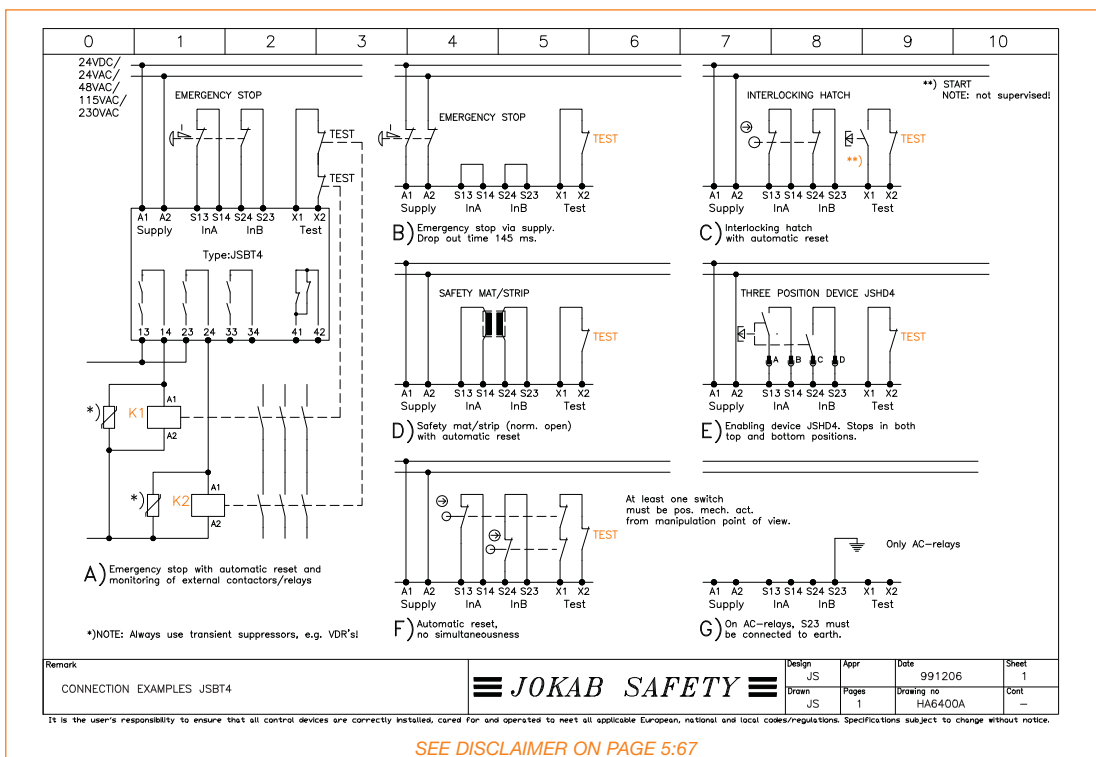

# General Drawing

## HA6500B Connection Example BT50

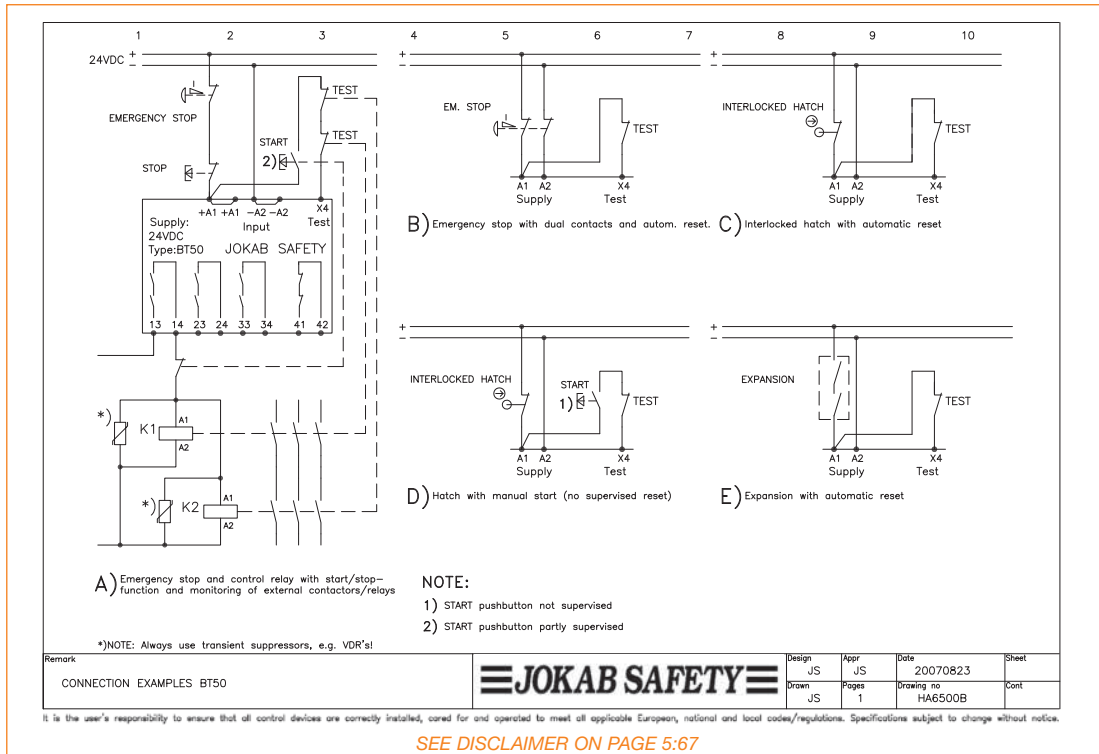

# General Drawing

## HA6501B Connection Example BT50T

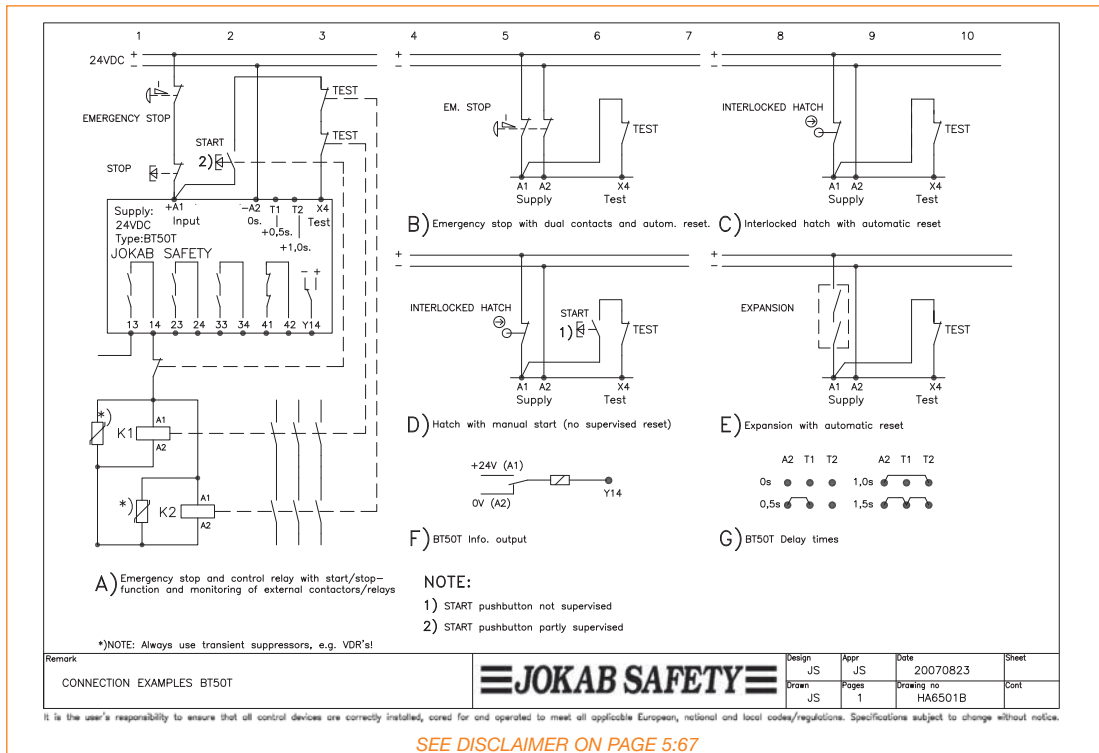

# General Drawing

## HA6500C Connection Example BT51

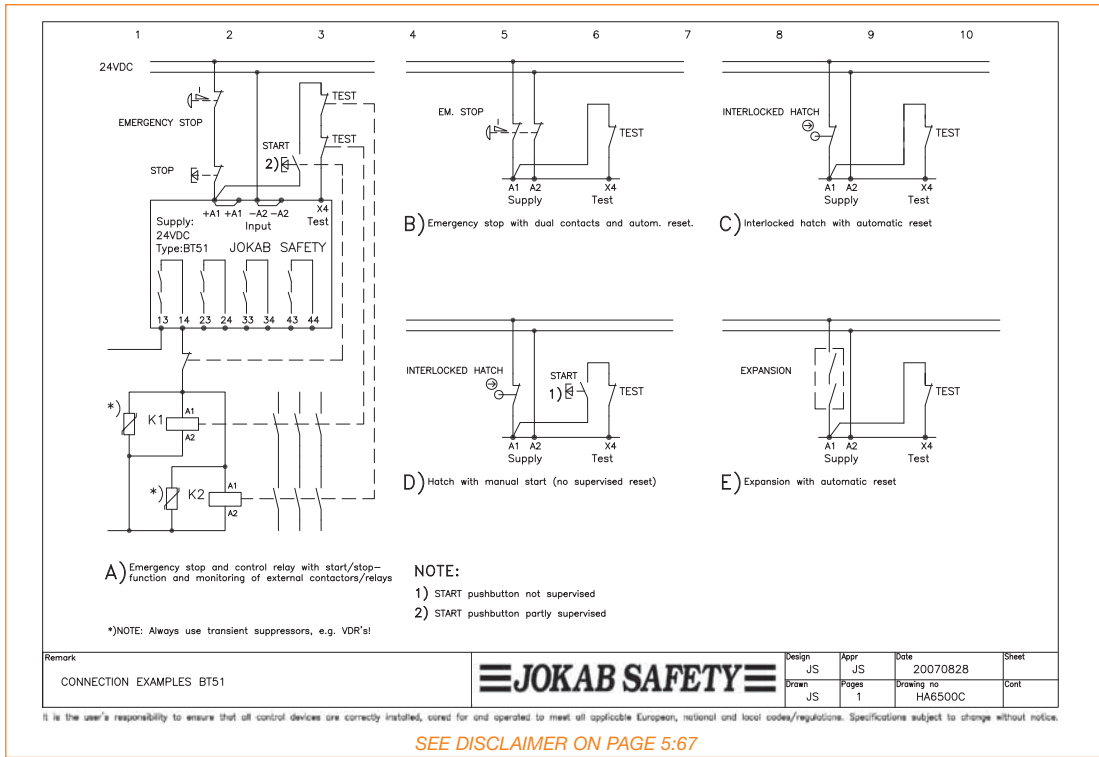

# General Drawing

## HA6501C Connection Example BT51T

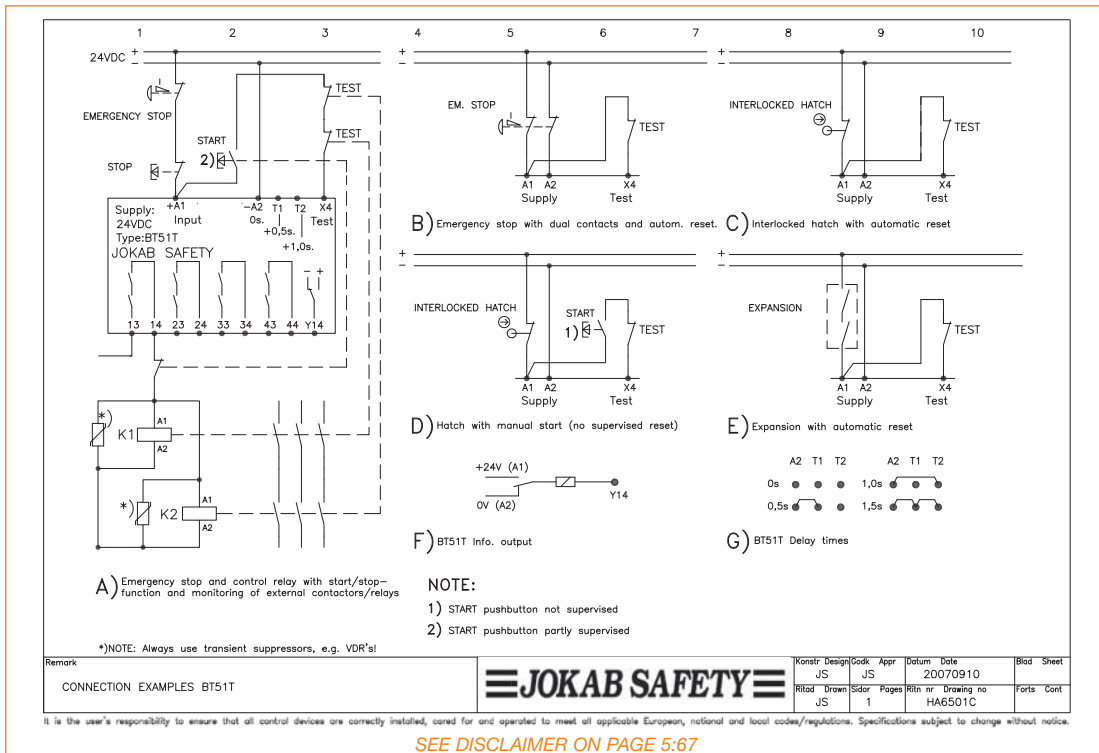

# General Drawing

## HA7100A Connection Example JSBRT11

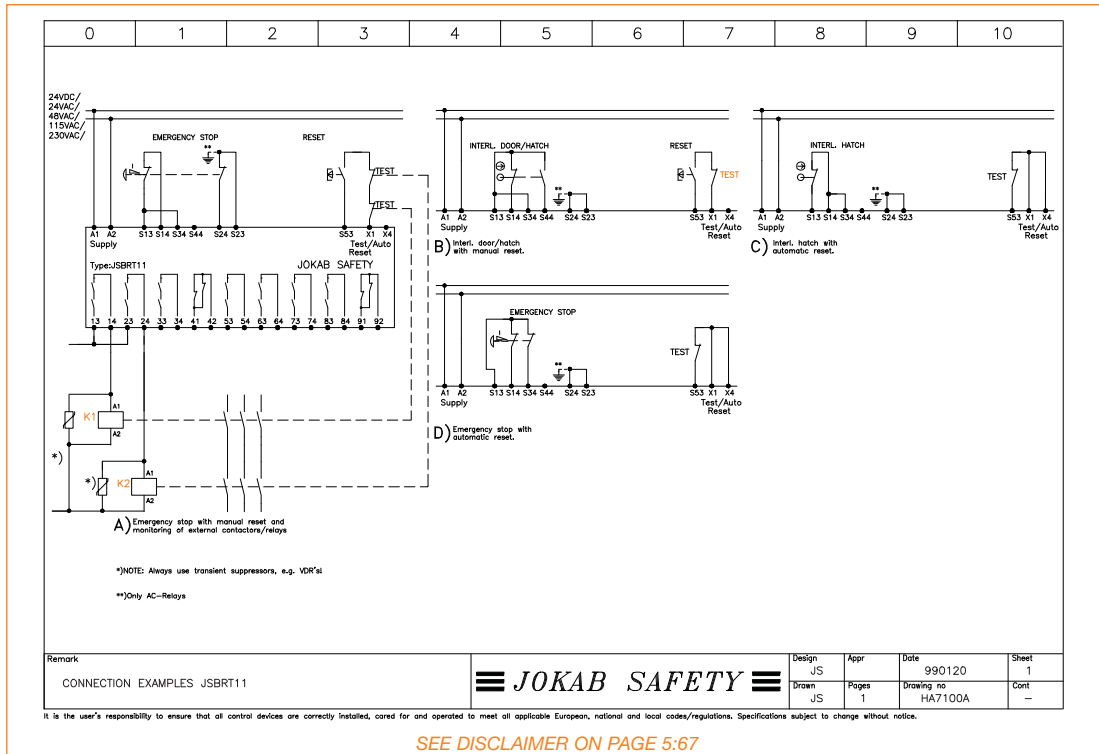

# General Drawing

## HA7600A Connection Example RT6

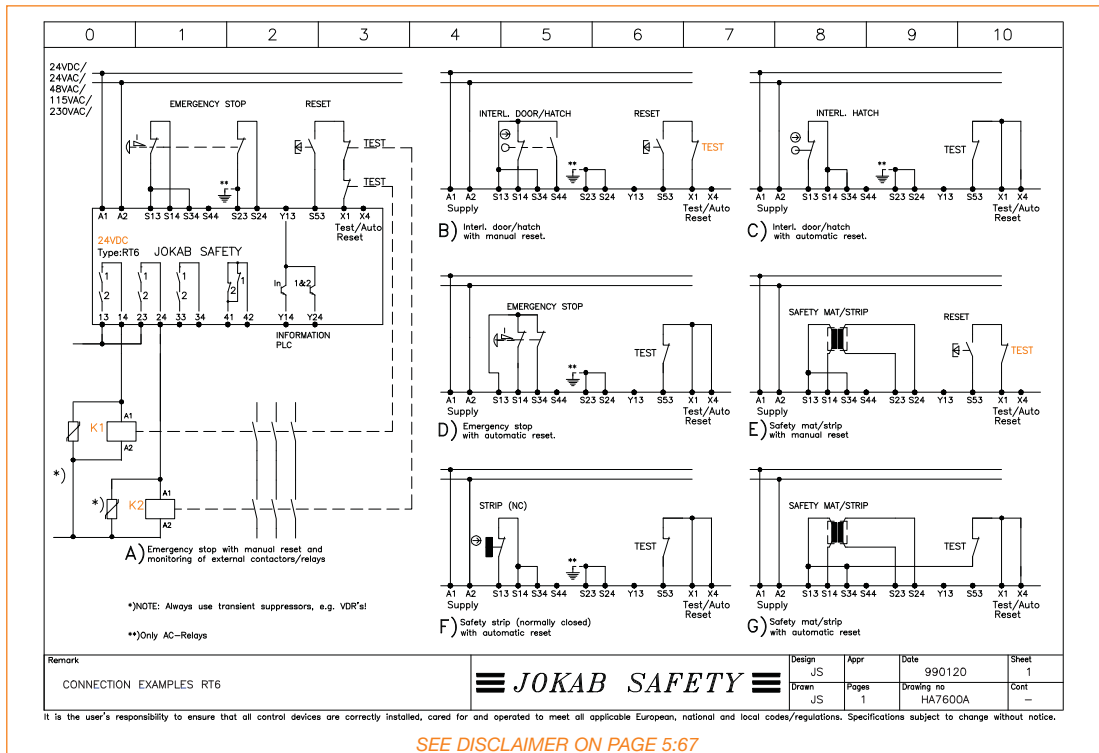

# General Drawing

## HA7600B Safety Mat, Emergency Stop and Hatch with RT6

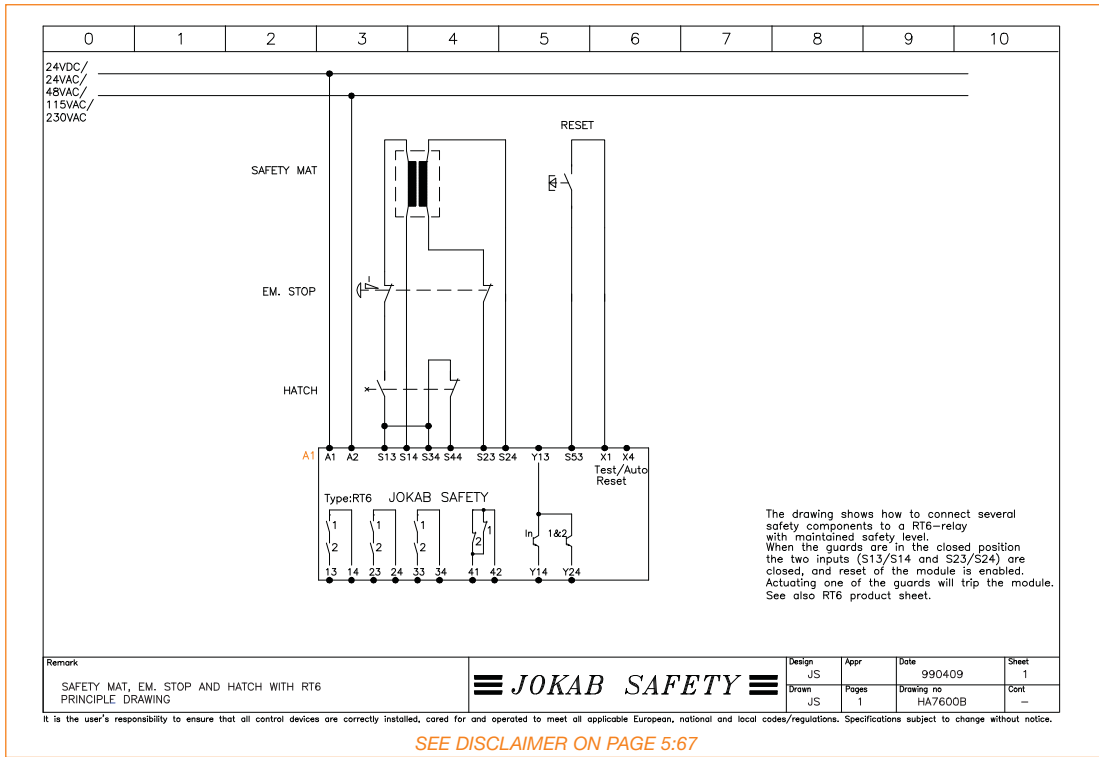

# General Drawing

## HA7672A Enabling Device JSHD4-EX with RT6

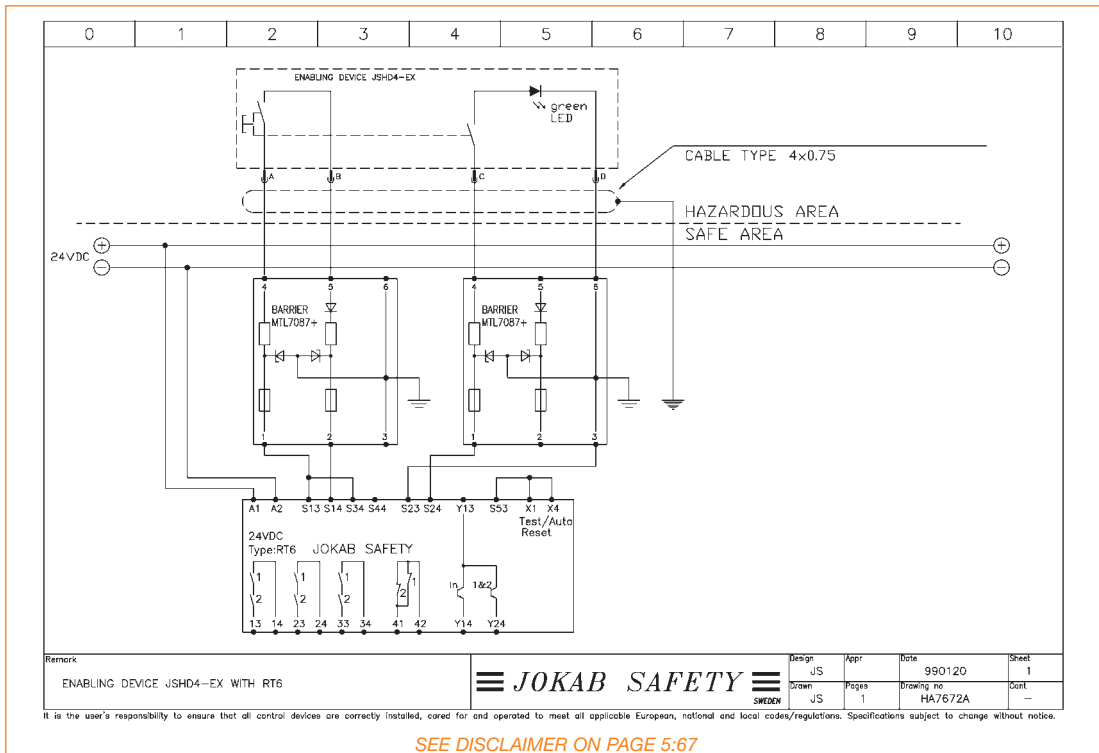

# General Drawing

## HA7700A Connection Example RT7

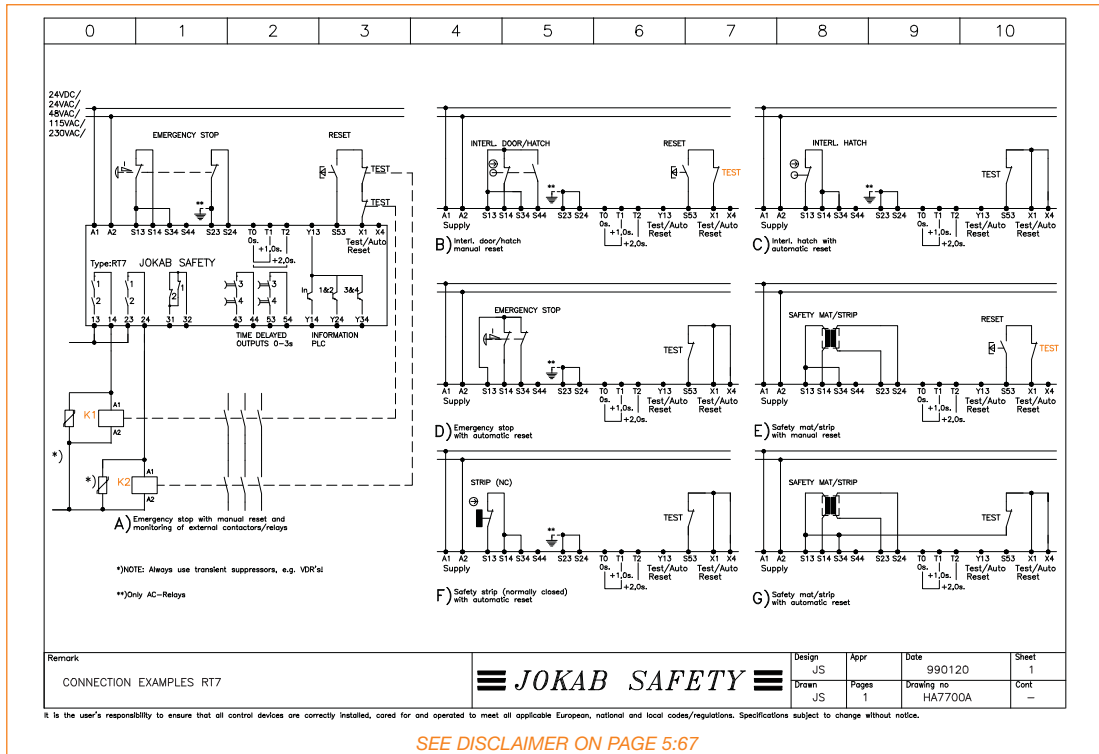

SEE DISCLAIMER ON PAGE 5:67

# General Drawing

## HA7900A Connection Example RT9

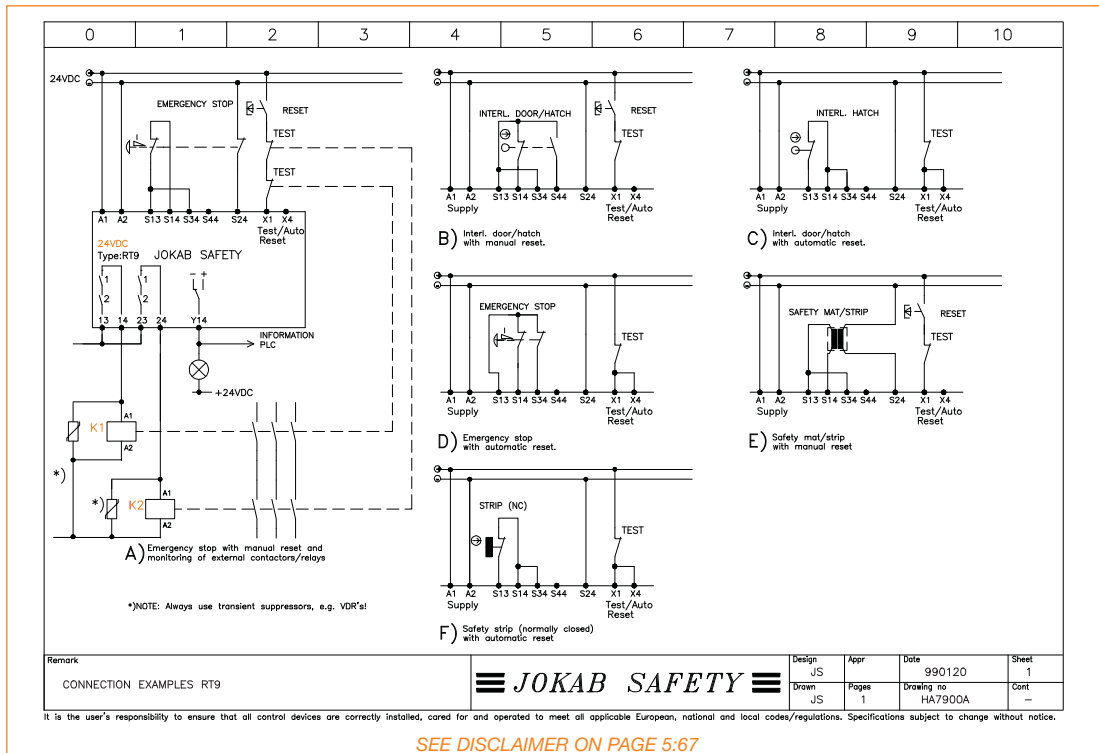

SEE DISCLAIMER ON PAGE 5:67



# Example with Safety Light Beam

## HE3811B Safety Light Beam Spot with Time-Limited Reset

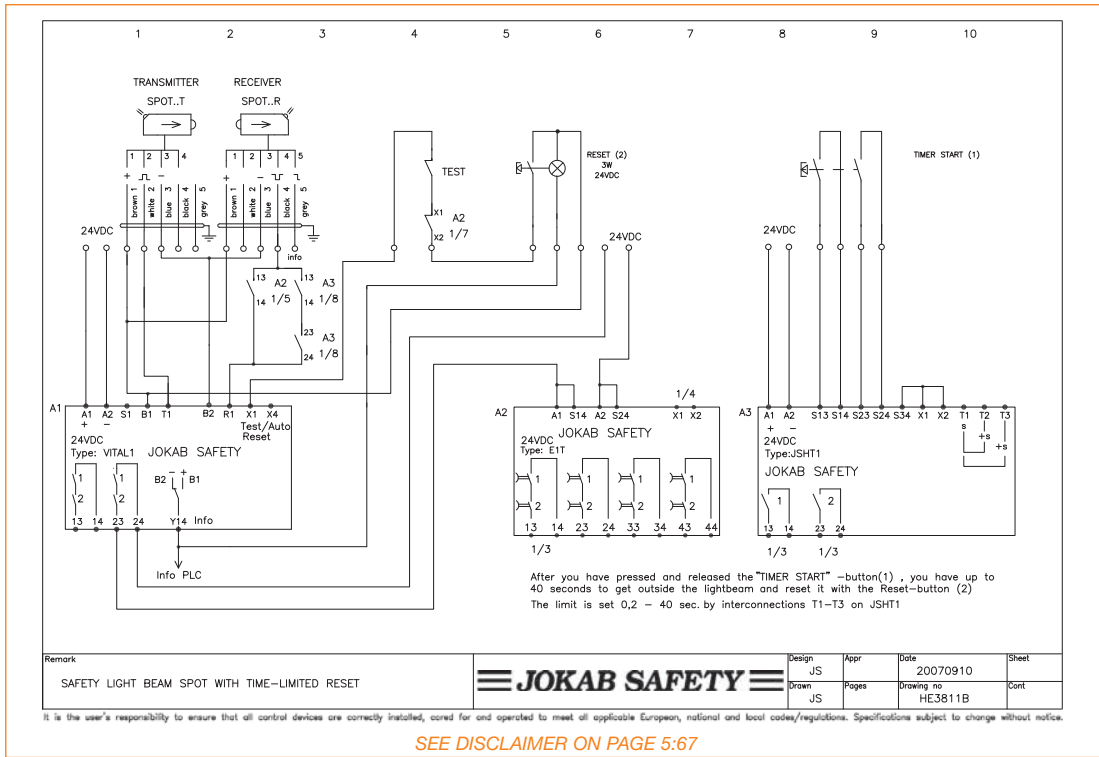

# Example with Safety Light Beam

## HE3824C Light Beam with Time-Limited Bypass 0.2-40 s

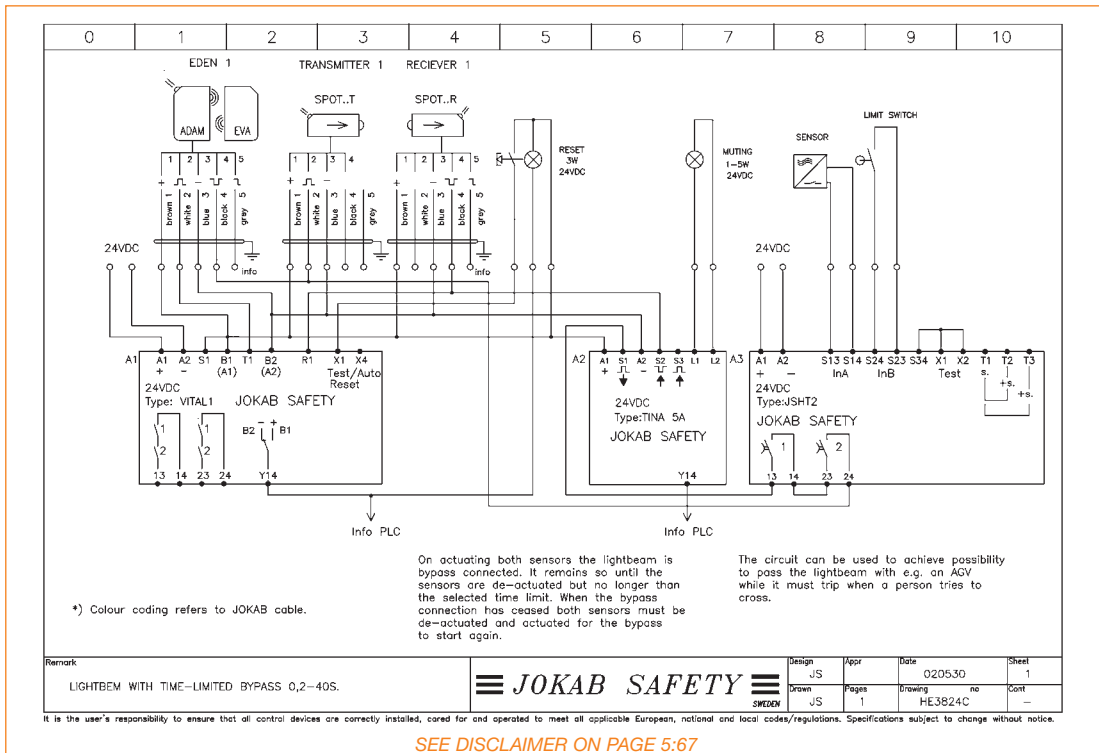

# Example with Safety Light Beam

## HG7636B Focus Light Grid/Curtain with Three-Position Device

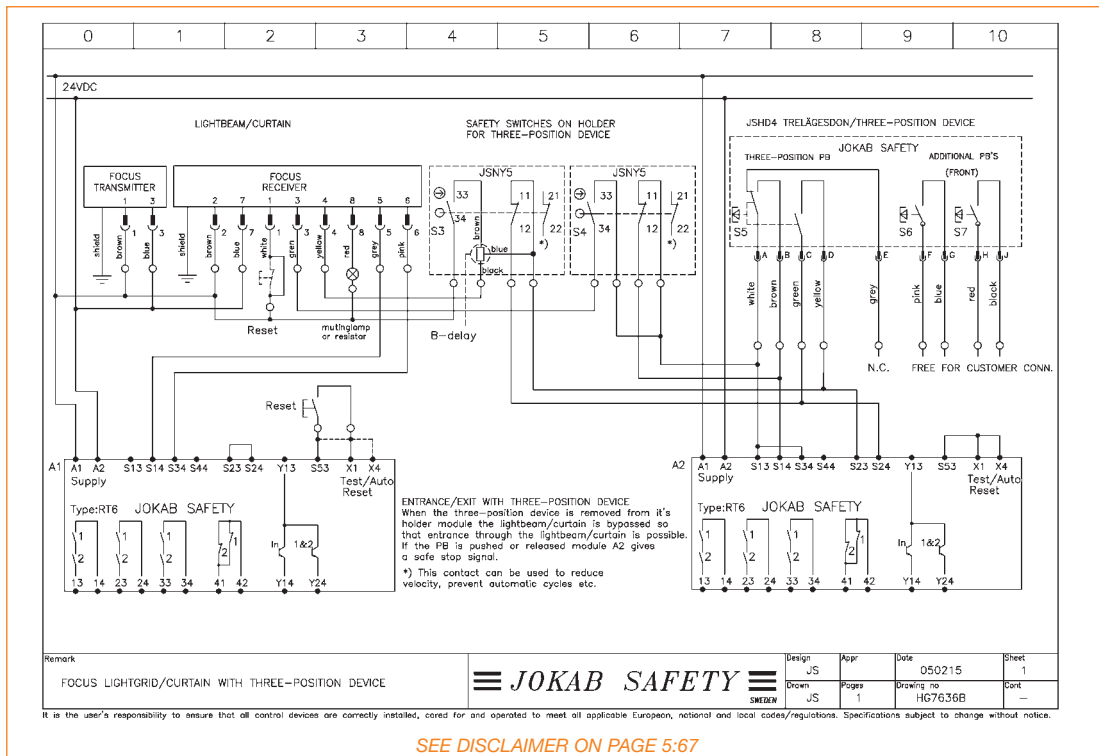

# Example with Interlocked Doors/Switches

## HG7611A Interlocked Door with RT6 and Pre-Reset

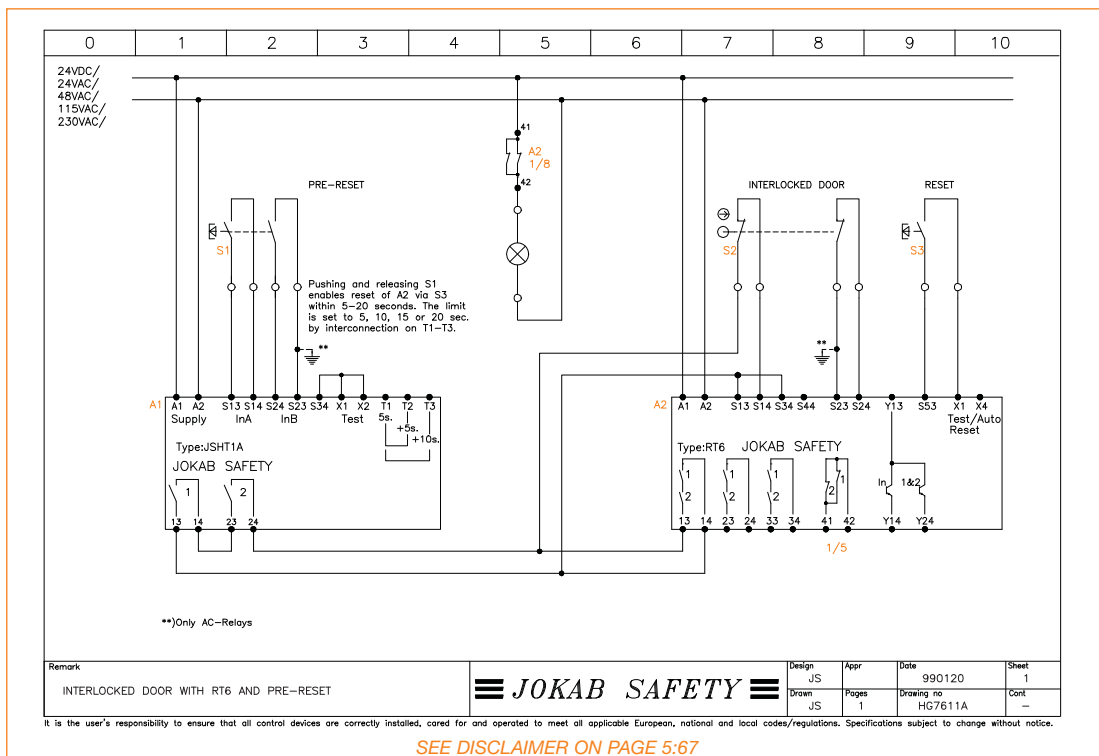

# Example with Interlocked Doors/Switches

## HG7636A Interlocked Door with Three-Position Device

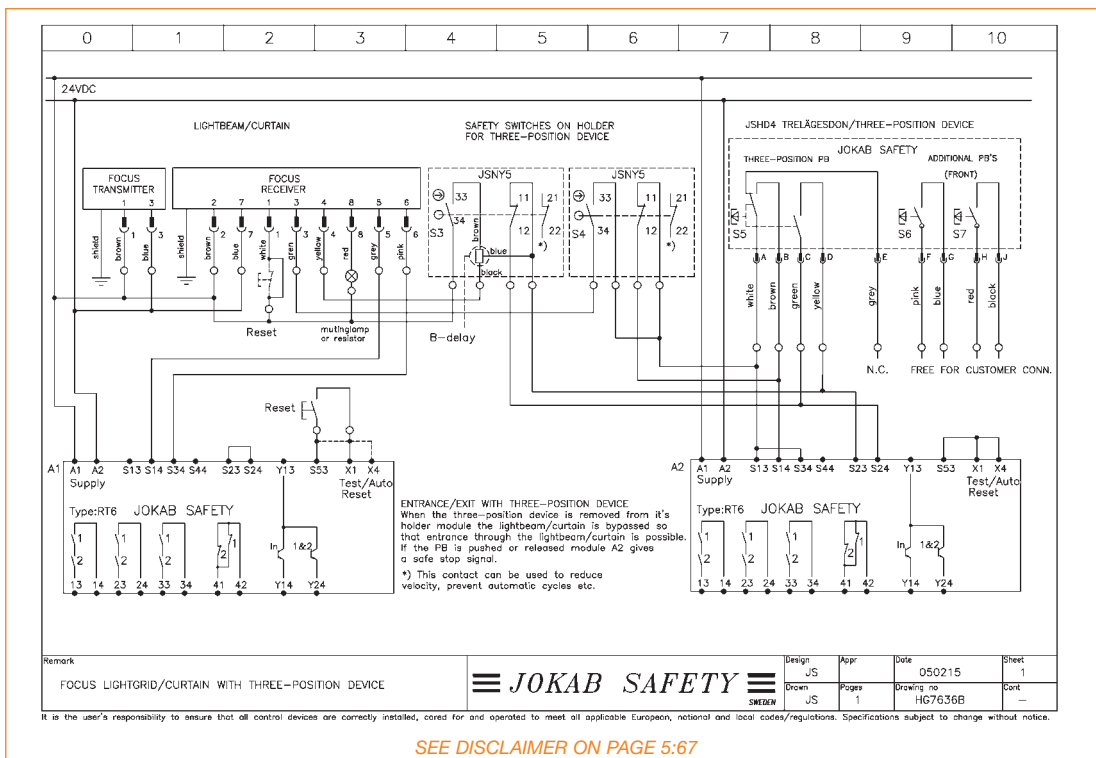

# Example with Interlocked Doors/Switches

## HG7646A Interlocked Door with Three-Position Device and Time-Limited Entrance/Exit

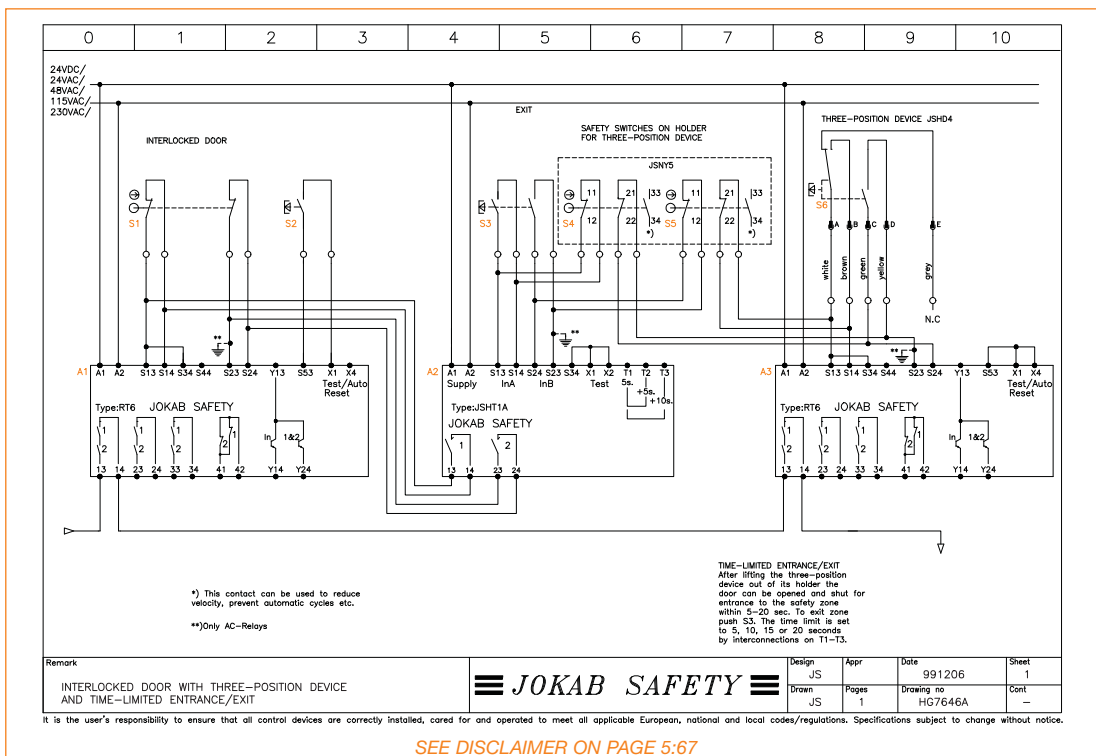

## Example with Interlocked Doors/Switches

### HG7654A Interlocked Door with RT6 and Output Expansion JSR1T

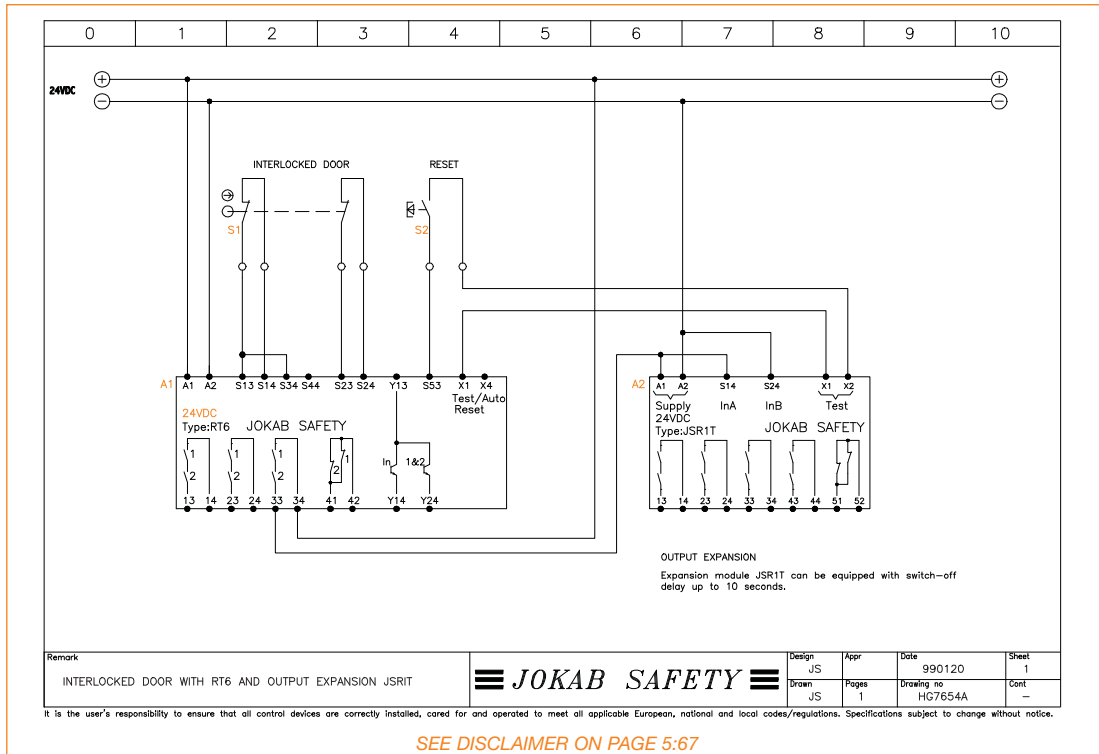

## Example with Interlocked Doors/Switches

### HG7658A Interlocked Door with RT6 and Output Expansion JSR2A

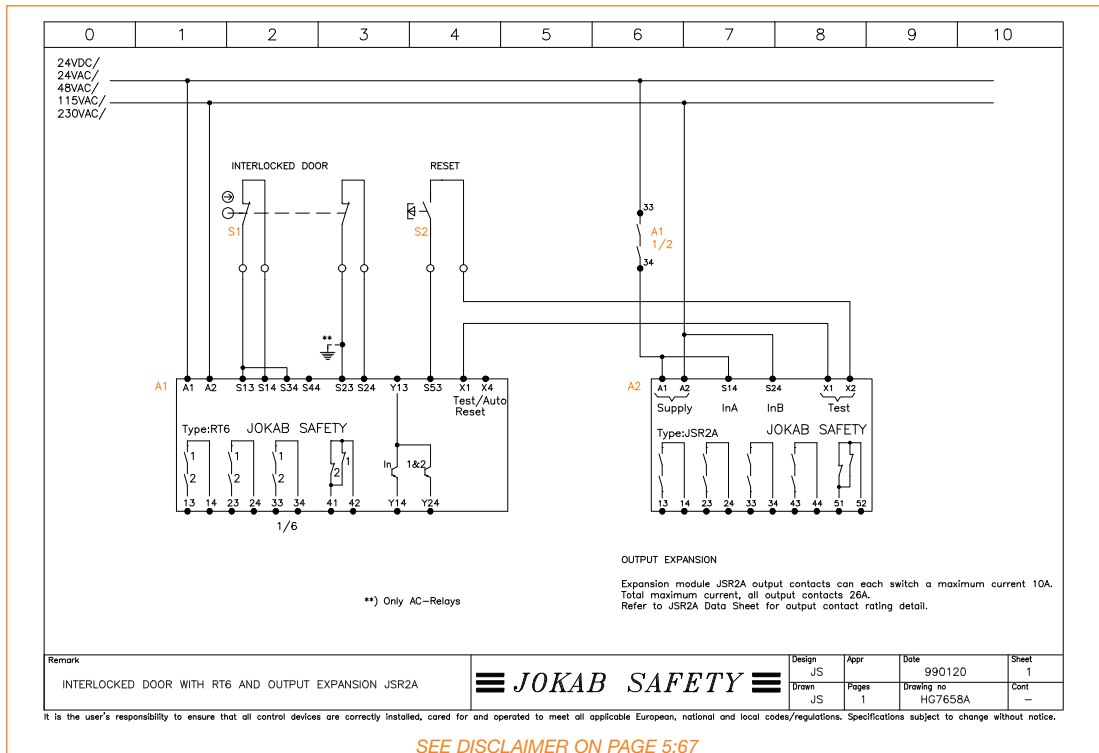

## Example with Interlocked Doors/Switches HG7673A Safety Interlock Switch JSNY8 with RT6

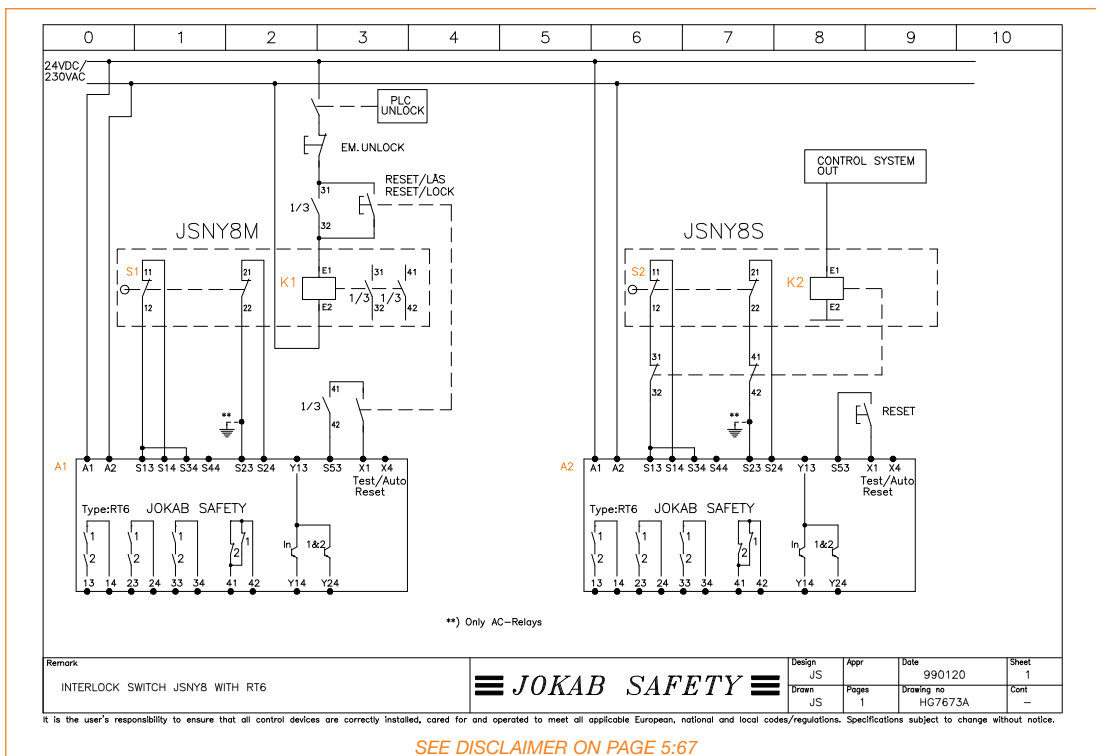

## Example with Interlocked Doors/Switches HA6500A Safety Interlock Switch JSBT5

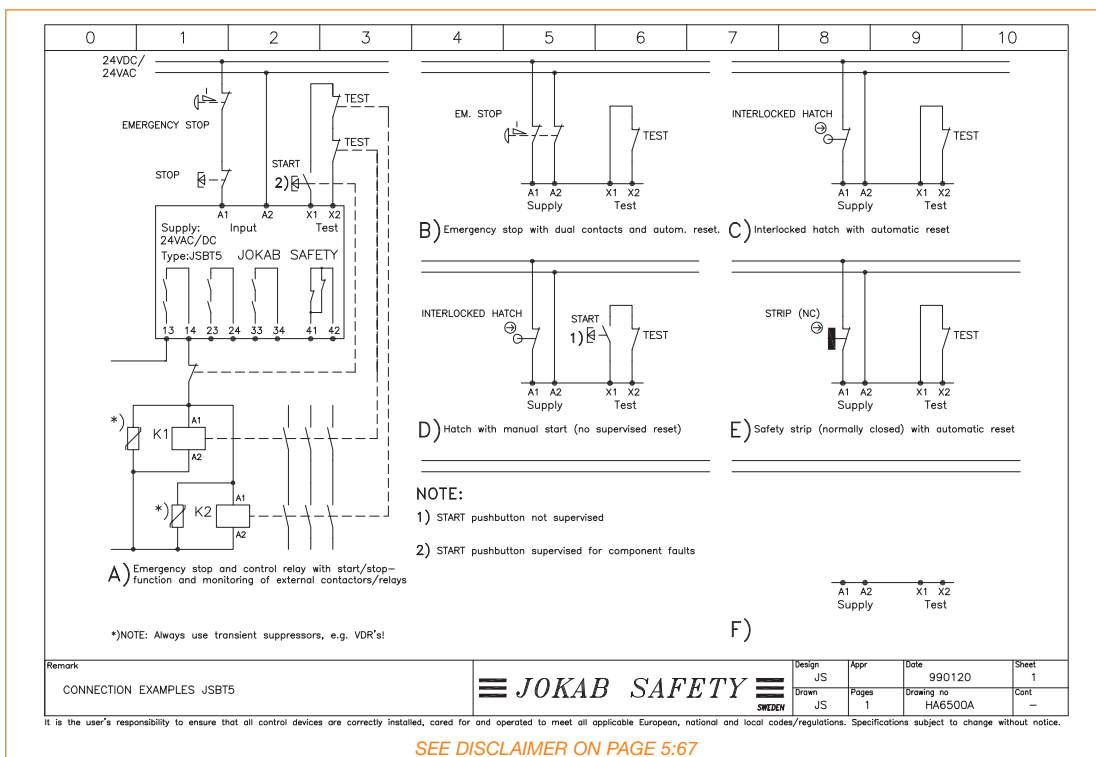

# Example with Interlocked Doors/Switches

## HG7674A Safety Interlock Switch JSNY9M/MLA with RT6

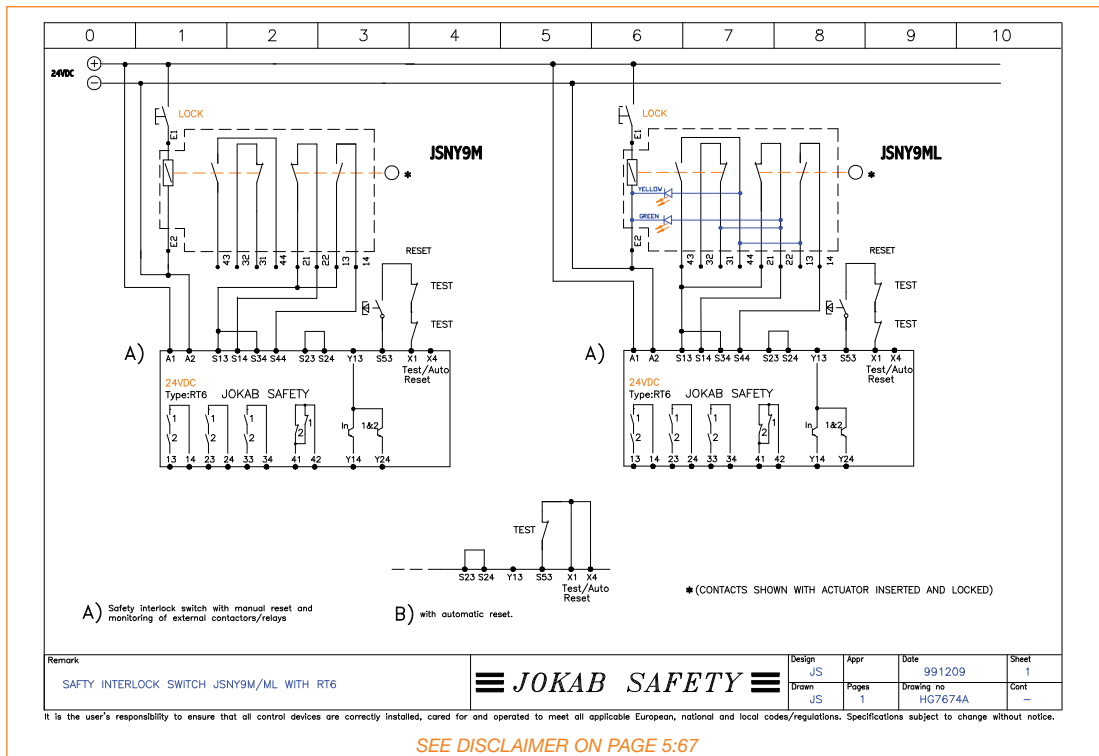

# Example with Interlocked Doors/Switches

## HG7674B Safety Interlock Switch JSNY9S/SLA with RT6

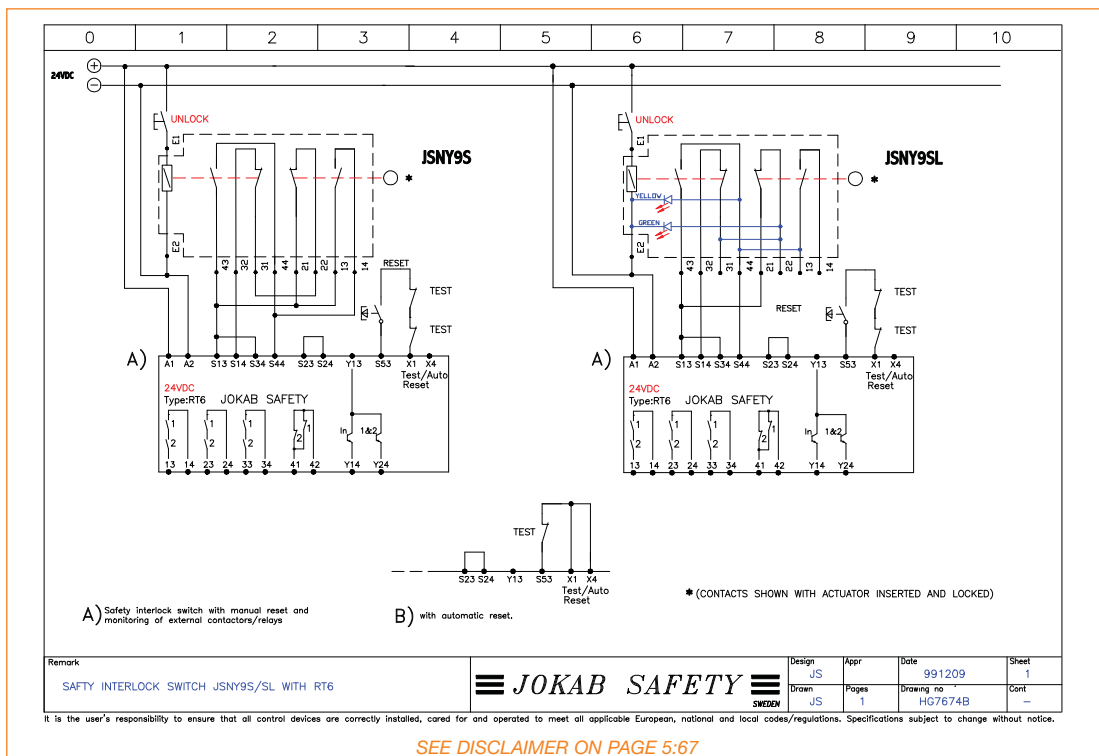

# Additional Example

## HH000C Three-Position Device JSHD4 with Various Safety Modules

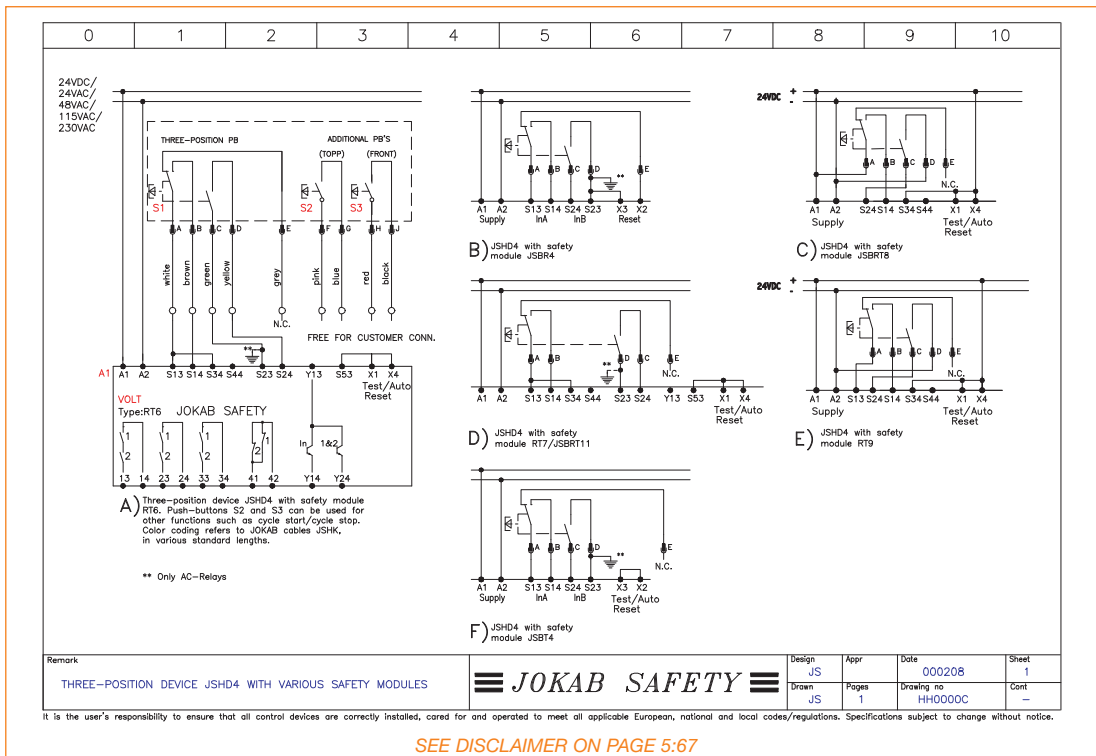

# Additional Example

## HI8552A Connection Example JSHT2 Intermittent Running

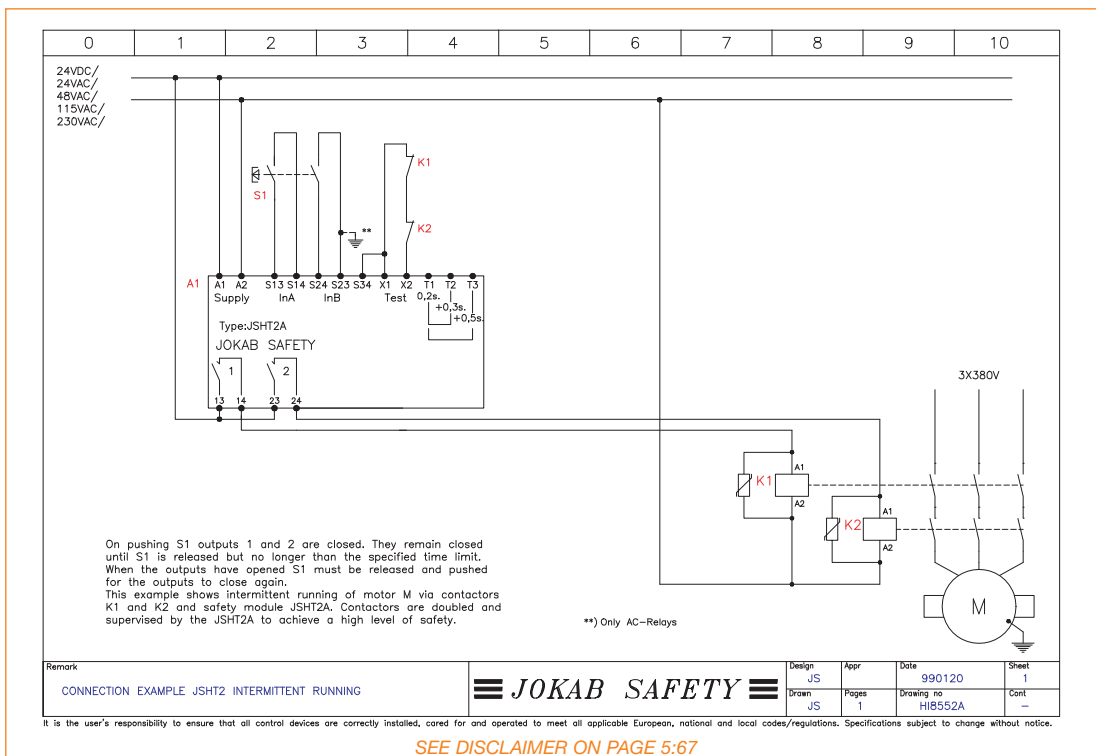

# Example with Safety Mats and Contact Strips

## HK7600A Safety Mat/Contact Strip with RT6

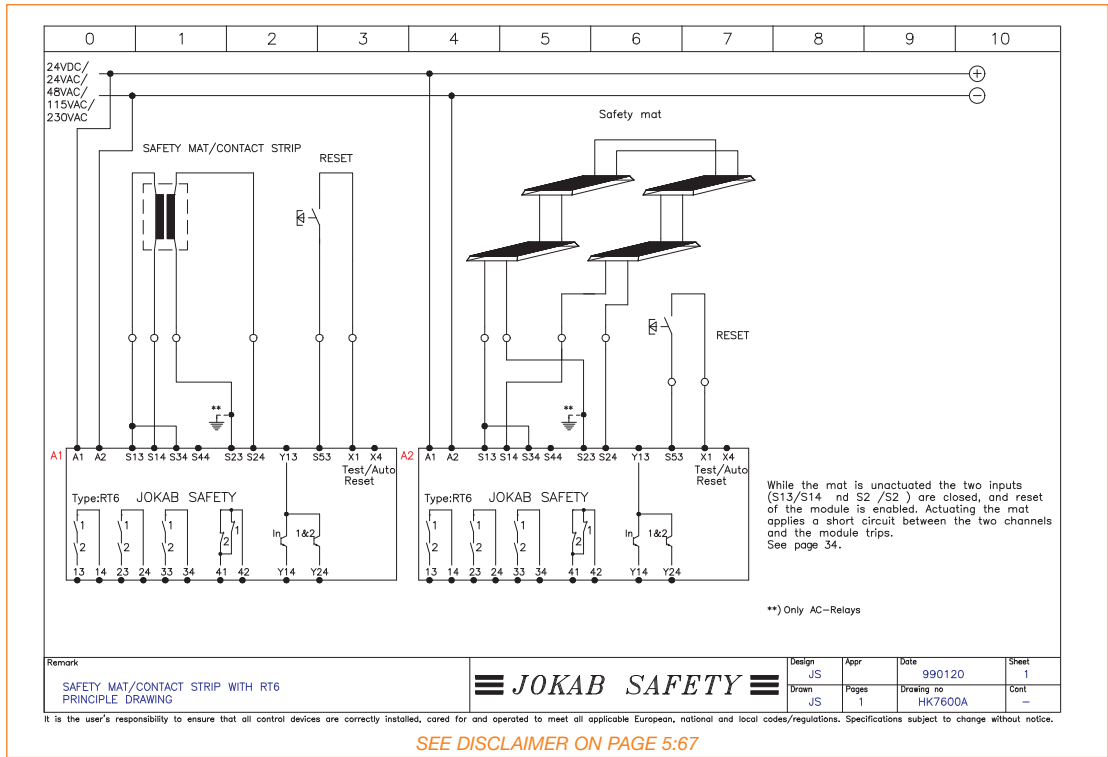

# Example with Hatches

## HL7600B Several JSNY7 connected to one RT6 with Unique Indication

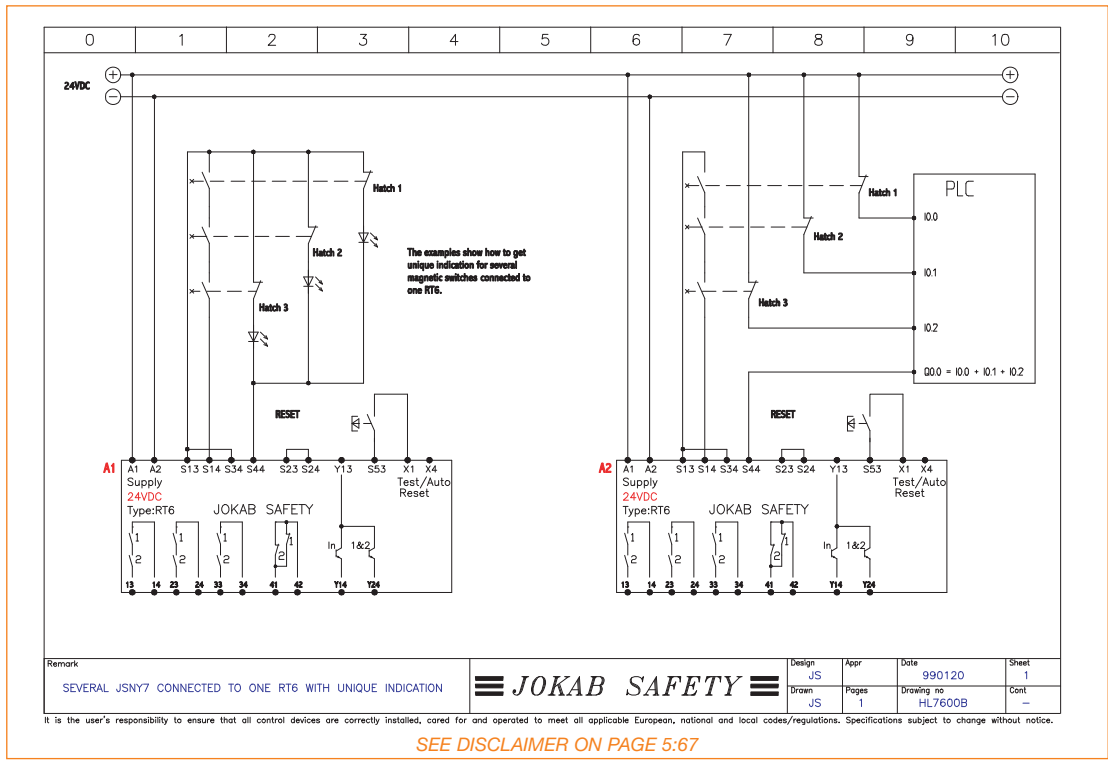



# Example with Magnetic Switches

## HM0000A Magnetic Switch JSNY7 with Various Safety Modules

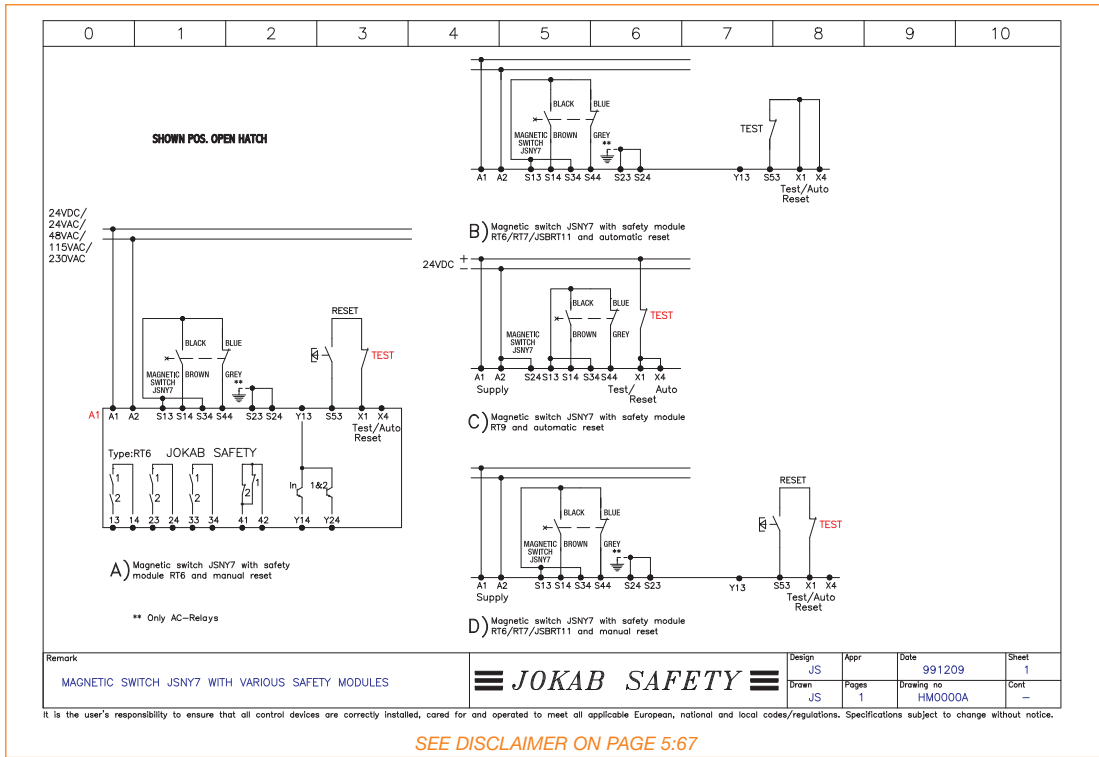

# Output Example

## HN7660A Delayed Outputs RT6 with Output Expansion JSR3T/RT7

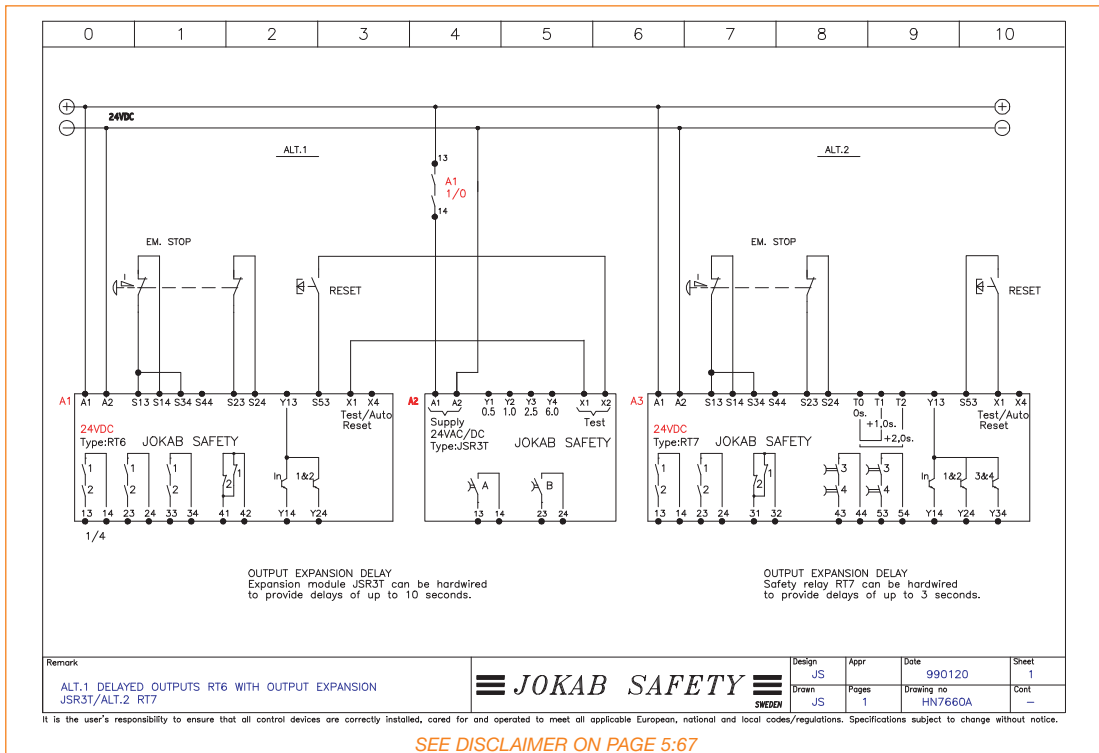

# Common Example

## HP7600A Machine Control - Isolation of PLC Inputs and Outputs

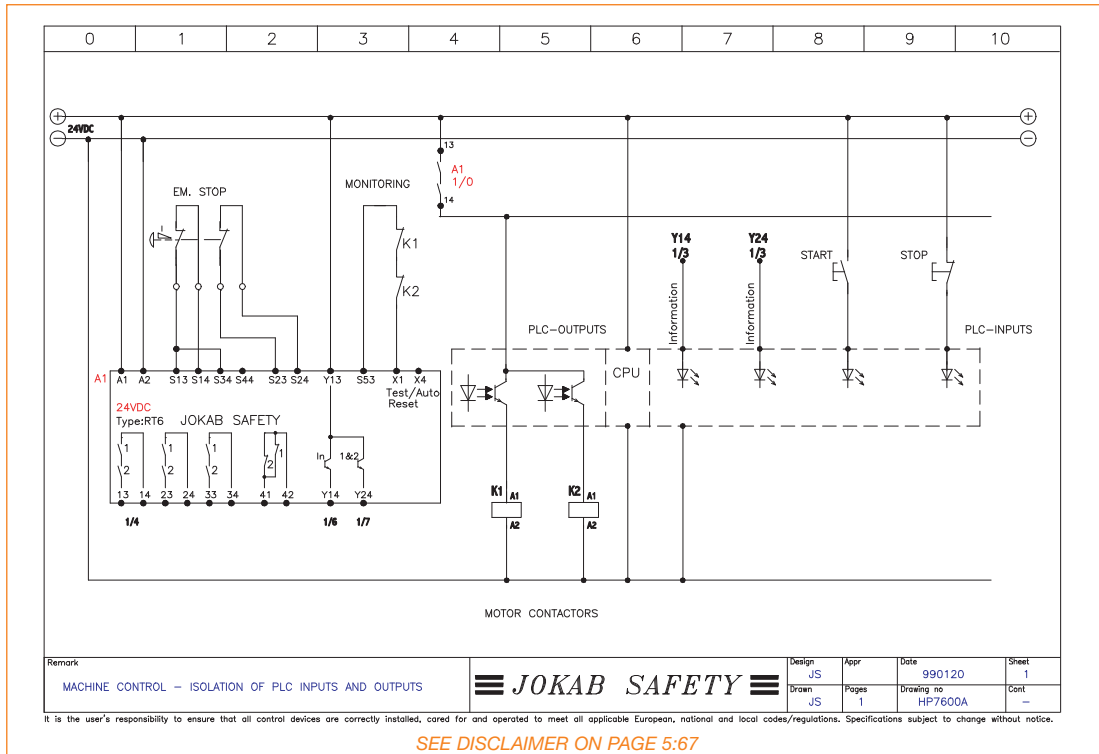

# Common Example

## HP7600B Machine Control - Isolation of PLC Outputs

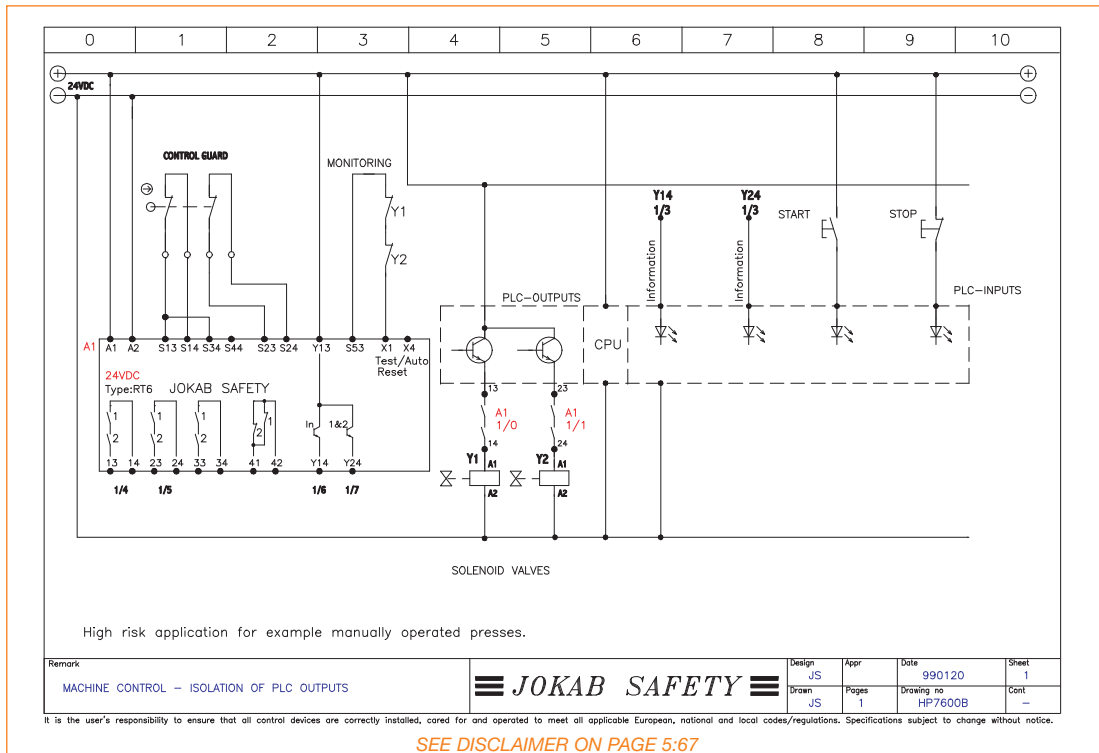





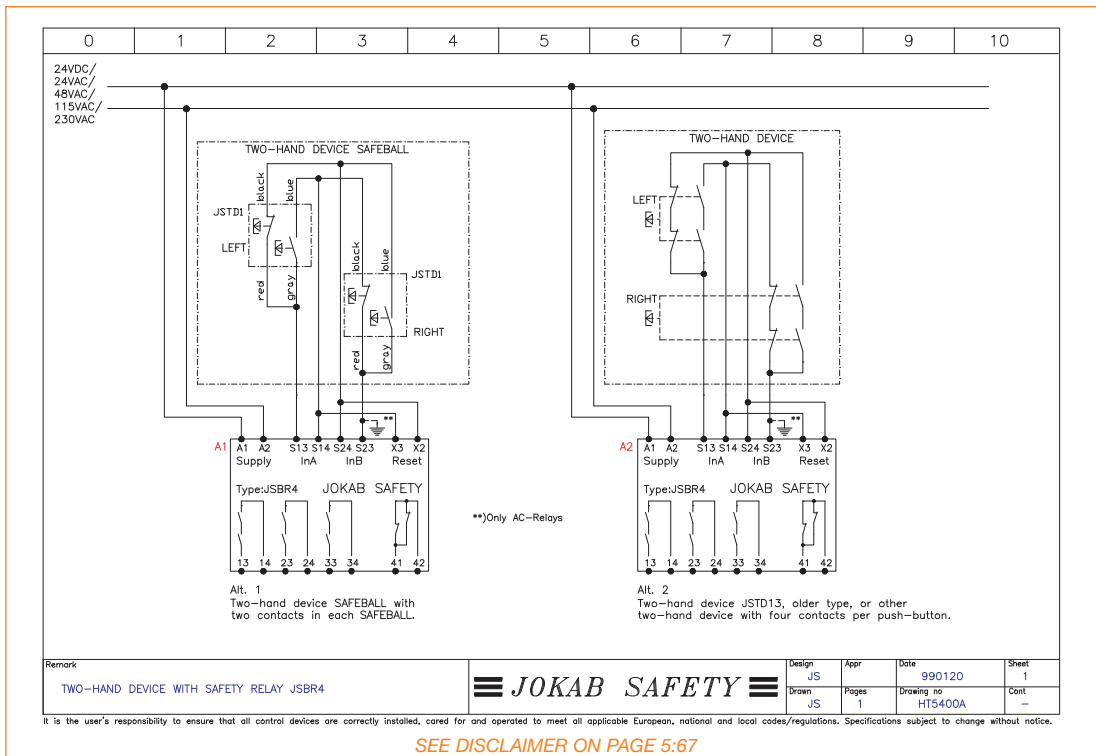



# Example with Two-Hand Device



## HT5400A Two-Hand Device with JSBR4









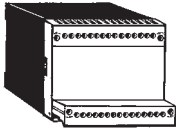
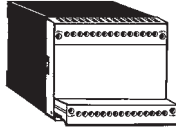
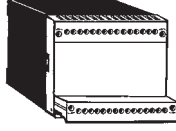
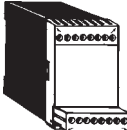
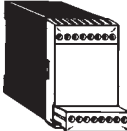
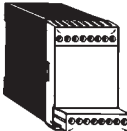

## Component List - Safety Relays

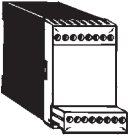
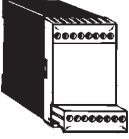
Designation		Ordering Information	Description
RT6 24VDC		2TLA010026R0000	Safety relay with 3 safety outputs, 5 selectable input options (single or dual channel), automatic or manual supervised reset, test input for monitoring of external positive guided relays/contactors, 5 LED indicators, 1 NC information output and 2 potential free transistor information outputs, quick release terminal blocks, 45mm wide, 24VDC supply. Meets safety category 1 to 4.
RT6 24VAC		2TLA010026R0200	Safety relay with 3 safety outputs, 5 selectable input options (single or dual channel), automatic or manual supervised reset, test input for monitoring of external positive guided relays/contactors, 5 LED indicators, 1 NC information output and 2 potential free transistor information outputs, quick release terminal blocks, 45mm wide, 24VAC supply. Meets safety category 1 to 4.
RT6 115VAC		2TLA010026R0400	Safety relay with 3 safety outputs, 5 selectable input options (single or dual channel), automatic or manual supervised reset, test input for monitoring of external positive guided relays/contactors, 5 LED indicators, 1 NC information output and 2 potential free transistor information outputs, quick release terminal blocks, 45mm wide, 115VAC supply. Meets safety category 1 to 4.
RT6 230VAC		2TLA010026R0500	Safety relay with 3 safety outputs, 5 selectable input options (single or dual channel), automatic or manual supervised reset, test input for monitoring of external positive guided relays/contactors, 5 LED indicators, 1 NC information output and 2 potential free transistor information outputs, quick release terminal blocks, 45mm wide, 230VAC supply. Meets safety category 1 to 4.
RT7 A 24VDC		2TLA010028R2000	Safety relay with 4 safety outputs (2 outputs can be off-delayed by 0, 0.5, 1 or 1.5 seconds via hardwire jumpers), 5 selectable input options (single or dual channel), automatic or manual supervised reset, test input for monitoring of external positive guided relays/contactors, 6 LED indicators, 1 NC information output and 3 potential free transistor information outputs, quick release terminal blocks, 45mm wide, 24VDC supply. Meets safety category 1 to 4.
RT7 A 115VAC		2TLA010028R2400	Safety relay with 4 safety outputs (2 outputs can be off-delayed by 0, 0.5, 1 or 1.5 seconds via hardwire jumpers), 5 selectable input options (single or dual channel), automatic or manual supervised reset, test input for monitoring of external positive guided relays/contactors, 6 LED indicators, 1 NC information output and 3 potential free transistor information outputs, quick release terminal blocks, 45mm wide, 115VAC supply. Meets safety category 1 to 4.
RT7 A 230VAC		2TLA010028R2500	Safety relay with 4 safety outputs (2 outputs can be off-delayed by 0, 0.5, 1 or 1.5 seconds via hardwire jumpers), 5 selectable input options (single or dual channel), automatic or manual supervised reset, test input for monitoring of external positive guided relays/contactors, 6 LED indicators, 1 NC information output and 3 potential free transistor information outputs, quick release terminal blocks, 45mm wide, 230VAC supply. Meets safety category 1 to 4.
RT7 B 24VDC		2TLA010028R1000	Safety relay with 4 safety outputs (2 outputs can be off-delayed by 0, 1, 2 or 3 seconds via hardwire jumpers), 5 selectable input options (single or dual channel), automatic or manual supervised reset, test input for monitoring of external positive guided relays/contactors, 6 LED indicators, 1 NC information output and 3 potential free transistor information outputs, quick release terminal blocks, 45mm wide, 24VDC supply. Meets safety category 1 to 4.





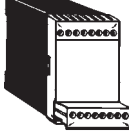

## Component List - Safety Relays

Designation		Ordering Information	Description
RT7 B 115VAC		2TLA010028R1400	Safety relay with 4 safety outputs (2 outputs can be off-delayed by 0, 1, 2 or 3 seconds via hardwire jumpers), 5 selectable input options (single or dual channel), automatic or manual supervised reset, test input for monitoring of external positive guided relays/contactors, 6 LED indicators, 1 NC information output and 3 potential free transistor information outputs, quick release terminal blocks, 45mm wide, 115VAC supply. Meets safety category 1 to 4.
RT7 B 230VAC		2TLA010028R1500	Safety relay with 4 safety outputs (2 outputs can be off-delayed by 0, 1, 2 or 3 seconds via hardwire jumpers), 5 selectable input options (single or dual channel), automatic or manual supervised reset, test input for monitoring of external positive guided relays/contactors, 6 LED indicators, 1 NC information output and 3 potential free transistor information outputs, quick release terminal blocks, 45mm wide, 230VAC supply. Meets safety category 1 to 4.
RT9 24VDC		2TLA010029R0000	Safety relay with 2 safety outputs, 5 selectable input options (single or dual channel), automatic or manual supervised reset, test input for monitoring of external positive guided relays/contactors, 5 LED indicators, 1 dual purpose information output, quick release terminal blocks, 22.5mm wide, 24VDC supply. Meets safety category 1 to 4.
JSBRT11 24VDC		2TLA010025R0000	Safety relay with 7 safety outputs, 4 selectable input options (single or dual channel), automatic or manual supervised reset, test input for monitoring of external positive guided relays/contactors, 5 LED indicators, 2 NC information outputs, quick release terminal blocks, 100mm wide, 24VDC supply. Meets safety category 1 to 4.
JSBRT11 115VAC		2TLA010025R0400	Safety relay with 7 safety outputs, 4 selectable input options (single or dual channel), automatic or manual supervised reset, test input for monitoring of external positive guided relays/contactors, 5 LED indicators, 2 NC information outputs, quick release terminal blocks, 100mm wide, 115VAC supply. Meets safety category 1 to 4.
JSBRT11 230VAC		2TLA010025R0500	Safety relay with 7 safety outputs, 4 selectable input options (single or dual channel), automatic or manual supervised reset, test input for monitoring of external positive guided relays/contactors, 5 LED indicators, 2 NC information outputs, quick release terminal blocks, 100mm wide, 230VAC supply. Meets safety category 1 to 4.
JSBR4 24VDC		2TLA010002R0000	Safety relay with 3 safety outputs, dual channel and two-hand device monitoring, manual supervised reset, test input for monitoring of external positive guided relays/contactors, 3 LED indicators, 1 NC information output, quick release terminal blocks, 45mm wide, 24VDC supply. Meets safety category 4. Dual input channel synchronism 0.5s.
JSBR4 24VAC		2TLA010002R0200	Safety relay with 3 safety outputs, dual channel and two-hand device monitoring, manual supervised reset, test input for monitoring of external positive guided relays/contactors, 3 LED indicators, 1 NC information output, quick release terminal blocks, 45mm wide, 24VAC supply. Meets safety category 4. Dual input channel synchronism 0.5s.
JSBR4 115VAC		2TLA010002R0400	Safety relay with 3 safety outputs, dual channel and two-hand device monitoring, manual supervised reset, test input for monitoring of external positive guided relays/contactors, 3 LED indicators, 1 NC information output, quick release terminal blocks, 45mm wide, 115VAC supply. Meets safety category 4. Dual input channel synchronism 0.5s.

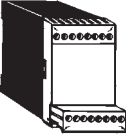
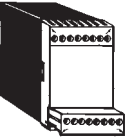
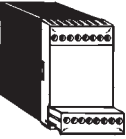
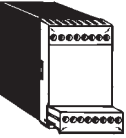
## Component List - Safety Relays

Designation		Ordering Information	Description
JSBR4 230VAC		2TLA010002R0500	Safety relay with 3 safety outputs, dual channel and two-hand device monitoring, manual supervised reset, test input for monitoring of external positive guided relays/contactors, 3 LED indicators, 1 NC information output, quick release terminal blocks, 45mm wide, 230VAC supply. Meets safety category 4. Dual input channel synchronism 0.5s.
JSBT4 24VDC		2TLA010004R0000	Safety relay with 3 safety outputs, dual channel, automatic reset, test input for monitoring of external positive guided relays/contactors, 3 LED indicators, 1 NC information output, quick release terminal blocks, 45mm wide, 24VDC supply. Meets safety category 4. Dual input channel synchronism 0.5s.
BT50 24VDC		2TLA010033R0000	Safety relay with 3 safety outputs, 1 NC status output, 2 selectable input options (single or dual channel), manual supervised reset, test input for monitoring of external positive guided relays/contactors, 3 LED indicators, quick release terminal blocks, 22.5 mm wide, 24VDC supply.
BT50T 24VDC		2TLA010033R1000	Safety relay with 3 safety outputs, 1 NC status output, 2 selectable input options (single or dual channel), manual supervised reset, test input for monitoring of external positive guided relays/contactors, 3 LED indicators, quick release terminal blocks, 22.5mm wide, 24VDC supply. Output delay times hardwire selectable between 0s, 0.5s, 1s or 1.5s.
BT51 24VDC		2TLA010033R2000	Safety relay with 4 safety outputs, 2 selectable input options (single or dual channel), manual supervised reset, test input for monitoring of external positive guided relays/contactors, 3 LED indicators, quick release terminal blocks, 22.5mm wide, 24VDC supply.
BT51T 24VDC		2TLA010033R3000	Safety relay with 4 safety outputs, 2 selectable input options (single or dual channel), manual supervised reset, test input for monitoring of external positive guided relays/contactors, 3 LED indicators, quick release terminal blocks, 22.5mm wide, 24 VDC supply. Output delay times hardwire selectable between 0s, 0.5s, 1s or 1.5s.
JSBT5 24VDC/AC		2TLA010005R0100	Safety timer relay with 3 NO outputs, selectable single or dual channel, test input for monitoring of external positive guided relays or contactors, 1 LED indicator, 22.5mm wide, 24VDC/AC supply. Meets safety category 1 to 4.
JSBT5 12VDC		2TLA010005R0700	Safety timer relay with 3 NO outputs, selectable single or dual channel, test input for monitoring of external positive guided relays or contactors, 1 LED indicator, 22.5mm wide, 12VDC supply. Meets safety category 1 to 4.
JSBT5T 24VDC/AC		2TLA010005R1100	Safety timer relay with 3 NO outputs, 500ms delayed, selectable single or dual channel, test input for monitoring of external positive guided relays or contactors, 1 LED indicator, 22.5mm wide, 24VDC/AC supply. Meets safety category 1 to 4.
JSHT1A 24VDC		2TLA010011R0000	Safety timer relay with 2 single NO outputs (hardwire time selection of 5, 10, 15 or 20 seconds timing function), selectable single or dual channel, test input for monitoring of external positive guided relays or contactors, 3 LED indicators, 45mm wide, 24VDC supply. Meets safety category 1 to 4. Quick release terminal blocks.

## Component List - Safety Relays

Designation		Ordering Information	Description
JSHT1B 24VDC		2TLA010011R1000	Safety timer relay with 2 single NO outputs (hardwire time selection of 5, 15, 30 or 40 seconds timing function), selectable single or dual channel, test input for monitoring of external positive guided relays or contactors, 3 LED indicators, 45mm wide, 24VDC supply. Meets safety category 1 to 4. Quick release terminal blocks.
JSHT2A 24VDC		2TLA010012R0000	Safety timer relay with 2 single NO outputs (hardwire time selection of 0.2, 0.5, 0.7 or 1 seconds timing function), selectable single or dual channel, test input for monitoring of external positive guided relays or contactors, 3 LED indicators, 45mm wide, 24VDC supply. Meets safety category 1 to 4. Quick release terminal blocks.
JSHT2B 24VDC		2TLA010012R1000	Safety timer relay with 2 single NO outputs (hardwire time selection of 5, 10, 15 or 20 seconds timing function), selectable single or dual channel, test input for monitoring of external positive guided relays or contactors, 3 LED indicators, 45mm wide, 24VDC supply. Meets safety category 1 to 4. Quick release terminal blocks.
JSHT2C 24VDC		2TLA010012R2000	Safety timer relay with 2 single NO outputs (hardwire time selection of 5, 15, 30 or 40 seconds timing function), selectable single or dual channel, test input for monitoring of external positive guided relays or contactors, 3 LED indicators, 45mm wide, 24VDC supply. Meets safety category 1 to 4. Quick release terminal blocks.
E1T 0s		2TLA010030R0000	Expansion relay with 4 safety outputs for expansion of safety relay, single or dual channel connection, 2 LED indicators, quick release terminal blocks, 22.5mm wide, 24VDC supply. Meets safety category 1 to 4.
E1T 0.5s		2TLA010030R1000	Expansion relay with 4 safety outputs (off-delayed by 500ms.) for expansion of safety relay, single or dual channel connection, 2 LED indicators, quick release terminal blocks, 22.5mm wide, 24VDC supply. Meets safety category 1 to 4.
E1T 1s		2TLA010030R2000	Expansion relay with 4 safety outputs (off-delayed by 1s.) for expansion of safety relay, single or dual channel connection, 2 LED indicators, quick release terminal blocks, 22.5mm wide, 24VDC supply. Meets safety category 1 to 4.
E1T 1.5s		2TLA010030R3000	Expansion relay with 4 safety outputs (off-delayed by 1.5s.) for expansion of safety relay, single or dual channel connection, 2 LED indicators, quick release terminal blocks, 22.5mm wide, 24VDC supply. Meets safety category 1 to 4.
E1T 2s		2TLA010030R4000	Expansion relay with 4 safety outputs (off-delayed by 2s.) for expansion of safety relay, single or dual channel connection, 2 LED indicators, quick release terminal blocks, 22.5mm wide, 24VDC supply. Meets safety category 1 to 4.
E1T 3s		2TLA010030R5000	Expansion relay with 4 safety outputs (off-delayed by 3s.) for expansion of safety relay, single or dual channel connection, 2 LED indicators, quick release terminal blocks, 22.5mm wide, 24VDC supply. Meets safety category 1 to 4.

## Component List - Safety Relays

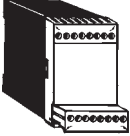
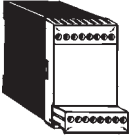
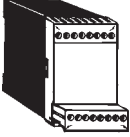
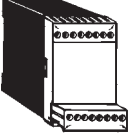
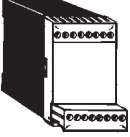
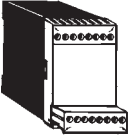
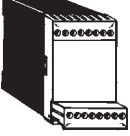
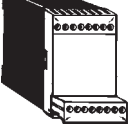
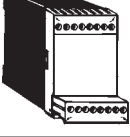
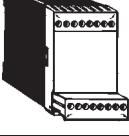
Designation	Ordering Information	Description
JSR1T 0s	 2TLA010015R0000	Expansion relay with 4 safety outputs for expansion of safety relay, single or dual channel connection, 2 LED indicators, 1 NC information output, quick release terminal blocks, 45mm wide, 24VDC supply. Meets safety category 1 to 4.
JSR1T 0.5s	 2TLA010015R1000	Expansion relay with 4 safety outputs (off-delayed by 500ms.) for expansion of safety relay, single or dual channel connection, 2 LED indicators, 1 NC information output, quick release terminal blocks, 45mm wide, 24VDC supply. Meets safety category 1 to 4.
JSR1T 1s	 2TLA010015R3000	Expansion relay with 4 safety outputs (off-delayed by 1s.) for expansion of safety relay, single or dual channel connection, 2 LED indicators, 1 NC information output, quick release terminal blocks, 45mm wide, 24VDC supply. Meets safety category 1 to 4.
JSR1T 1.5s	 2TLA010015R0500	Expansion relay with 4 safety outputs (off-delayed by 1.5s.) for expansion of safety relay, single or dual channel connection, 2 LED indicators, 1 NC information output, quick release terminal blocks, 45mm wide, 24VDC supply. Meets safety category 1 to 4.
JSR1T 2s	 2TLA010015R4000	Expansion relay with 4 safety outputs (off-delayed by 2s.) for expansion of safety relay, single or dual channel connection, 2 LED indicators, 1 NC information output, quick release terminal blocks, 45mm wide, 24VDC supply. Meets safety category 1 to 4.
JSR1T 3s	 2TLA010015R5000	Expansion relay with 4 safety outputs (off-delayed by 3s.) for expansion of safety relay, single or dual channel connection, 2 LED indicators, 1 NC information output, quick release terminal blocks, 45mm wide, 24VDC supply. Meets safety category 1 to 4.
JSR1T 5s	 2TLA010015R6000	Expansion relay with 4 safety outputs (off-delayed by 5s.) for expansion of safety relay, single or dual channel connection, 2 LED indicators, 1 NC information output, quick release terminal blocks, 45mm wide, 24VDC supply. Meets safety category 1 to 4.
JSR1T 8s	 2TLA010015R0600	Expansion relay with 4 safety outputs (off-delayed by 8s.) for expansion of safety relay, single or dual channel connection, 2 LED indicators, 1 NC information output, quick release terminal blocks, 45mm wide, 24VDC supply. Meets safety category 1 to 4.
JSR1T 10s	 2TLA010015R2000	Expansion relay with 4 safety outputs (off-delayed by 10s.) for expansion of safety relay, single or dual channel connection, 2 LED indicators, 1 NC information output, quick release terminal blocks, 45mm wide, 24VDC supply. Meets safety category 1 to 4.
JSR2A 10A 24VDC/AC	 2TLA010027R0100	Expansion relay with 4 safety outputs (10A/250V maximum rating) for expansion of safety relay, single or dual channel connection, 3 LED indicators, 1 NC information output, quick release terminal blocks, 45mm wide, 24VDC/AC supply. Meets safety category 1 to 4.

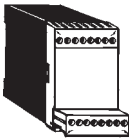
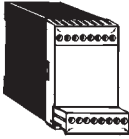
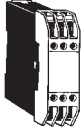

## Component List - Safety Relays

Designation		Ordering Information	Description
JSR2A 10A 115VAC		2TLA010027R0400	Expansion relay with 4 safety outputs (10A/250V maximum rating) for expansion of safety relay, single or dual channel connection, 3 LED indicators, 1 NC information output, quick release terminal blocks, 45mm wide, 115VAC supply. Meets safety category 1 to 4.
JSR2A 10A 230VAC		2TLA010027R0500	Expansion relay with 4 safety outputs (10A/250V maximum rating) for expansion of safety relay, single or dual channel connection, 3 LED indicators, 1 NC information output, quick release terminal blocks, 45mm wide, 230VAC supply. Meets safety category 1 to 4.
JSR3T 24VAC/DC		2TLA010017R0100	Expansion relay with 2 single NO outputs (hardwire selectable off-delay of 500ms. to 10s.) for expansion of safety relay, single or dual channel connection, 1 LED indicator, 22.5mm wide, 24VAC/DC supply. Meets safety category 1 to 4.

This document and any attachments may include suggested specifications, drawings, schematics and similar materials from ABB Inc. Use of such information and/or documentation by the recipient is subject to and conditioned upon your acceptance of the terms of the General Document Disclaimer which can be found at [www.jokabsafetyna.com](http://www.jokabsafetyna.com). Your acceptance of the terms of such General Document Disclaimer is conclusively presumed unless you notify ABB in writing of your disagreement with the terms of such Disclaimer immediately upon receipt of this document and you return to ABB all specifications, drawings, schematics and similar materials provided to you by ABB.

Notes

# Focus Light Curtains and Light Grids

Point of operation guarding!  
 Passable protection in risk areas!  
 Built-in muting capabilities!



Why should I use Light Curtains and Light Grids?.....	6:2
How do Light Curtains and Light Grids work?.....	6:3
What are the safety requirements for an Optical Protective Device? .....	6:3
Minimal Safe Distance Calculation .....	6:4
Focus II Light Curtains and Light Grids.....	6:6
Muting with FMC and FMI Units.....	6:13
Muting with MFII and MFII-L Units .....	6:15
Muting with MFII-T Reflex and MFII-L Reflex Units.....	6:16
Focus Summary .....	6:17
Bjorn Stand System for Light Grids and Mirrors .....	6:19
Wet Wash Down Tubes .....	6:21
Spot Safety Light Beam.....	6:22
BP1 Blanking Programmer.....	6:27
Muting Sensor Mute R Retro/Reflective with Polarizing Filters .....	6:28
Muting Sensor Mute D Diffuse/Reflective with Background Rejection.....	6:29
JSRL-3 Laser Aligner .....	6:30
Connection Examples .....	6:31
Component List and Ordering Information .....	6:39

# Why should I use Safety Light Curtains and Grids?

## ...to provide operator protection during production!

A Safety Light Curtain can be used on a machine or in a production plant in the same way as a hatch or door. There are great differences though when it comes to the component installation and functionality. When a Light Curtain is mounted on a hazardous machine, we are not only concerned with the response times of the safety systems, but also the Depth Penetration Factors. It is possible for the operator's fingers or hands to pass through the Light Curtain a certain distance before being detected. This becomes the Depth Penetration Factor. This distance must also be entered into the Minimal Safety Distance Calculation for the machine (see page 6:4).

It is also very important that the level of safety of the Light Curtain with dual supervised outputs be continued throughout the rest of the stopping control circuit. Even valves and contactors, which ultimately control dangerous movements, normally have to be redundant and monitored.

### Automatic Machines

For Light Curtains on automatic machines there shall be a reset function which is active when the machine is set for automatic production, whether or not it is a passable protection. After an engagement one must first use a reset function, then the restart of the cycle should be made with a separate starting device. The same reset applies for machines with semi-automatic drives.

### Mechanical and Hydraulic Presses

Light Curtain applications are often categorized by the type of guarding required. Protecting an operator from the hazards associated with material positioning or where a process is performed is called Point of Operation Guarding. The point of operation is often called the Zone of Hazardous Operation or the Pinch Point.

This type of guarding is associated with mechanical and hydraulic power presses, molding presses, stamping, forming, riveting, eyelet and automated assembly machinery. Light Curtains used in these applications are typically selected for finger and hand protection.

### During Manual Servicing of Machines

With manually operated machines where one or more operators move parts in and out between every cycle. This type of application is the most risky because the number of engagements into the machine's dangerous area is often several times per minute.

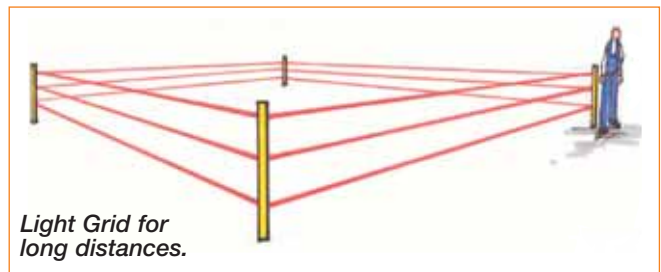
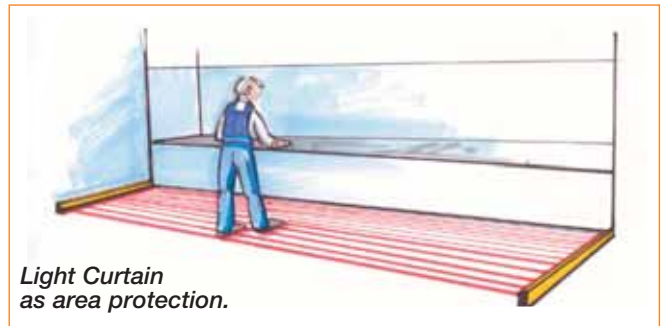

## ...to provide passable protection into risk areas!

Both Light Curtains and Light Grids can often be used as passable protection into a risk area. This is called passable protection because it is possible to get in behind the safety device. Common applications are robot installations, openings for in and out passage of material, etc. The choice between Light Curtain or Light Grid is often a question of available safety distance, reach and price. Light Curtains are often chosen for short safety distances Light Grids are chosen for long reach—up to 50 m—and for a low price.

# How do Light Curtains and Light Grids work?

Both Light Curtains and Light Grids utilize optical transmitter and receiver units. Beams of infrared light are sent to the receiver from the transmitters. When a light beam is interrupted, a dual stop signal is given to the dangerous machines inside the Light Curtain/Grid protected area.

## What is the difference between a Light Curtain and a Light Grid?

A Light Curtain has several beams that are placed closely together, while a Light Grid consists of only one, two, three or four Light Beams.

The beams are closest on a Light Curtain that is used for finger detection, with a resolution of 14mm. Light Curtain beams are at their widest spacing when



Resolution for hands.



Resolution for fingers.

used for hand detection, with a resolution of 30mm.

For Light Grids the beams are normally placed at a relative distance of 200 to 500mm.

# What are the safety requirements for an Optical Protective Device?

High safety demands are stated in the standard EN 61 496-1 which deals with light protection. The main demands are on a safe stopping function and that light from light sources other than the transmitter or other disturbances do not affect the safety function.

Depending on how the safety function is built up, there are safety components of type 2 and 4 to choose between. Type 2 and 4 relates in principle category 2/PL c and category 4/PL e according to EN ISO 13849-1.

Type 4, which has the highest safety level, states that a fault is not allowed to affect the safety function and that the fault should be detected by the outputs falling immediately or that they do not reconnect after being disconnected. Maximum allowed scattering angle for the light is  $\pm 2^\circ$ .

Type 2 states that a simple but monitored safety function is required, which means that the safety function should be monitored through periodic tests which break the output when a fault occurs. Although, between the testing times there can be faults which result in the safety component malfunctioning. The test function can either be built into the safety device or an external unit (e.g. the machine's control system) can initiate a test. Maximum allowed scattering angle for the light is  $\pm 4^\circ$ .

Light Grids and Light Curtains are included among the products in the machine directive's appendix 4, which means that an external certifying procedure with an officially recognized institution is called for.



Safety Certifications



## Minimal Safe Distance Calculation

The Minimal Safe Distance Calculation shall guarantee that a person is not able to reach a dangerous machine part before the machine movement has stopped. This is calculated with the formula as called for from the *ANSI B11.19-2003 Performance Criteria*

$$D_s = [K \times (T_s + T_c + T_r + T_{spm})] + D_{pf}$$

Where:

$D_s$  = minimum safe distance between the safeguarding device and the hazard

$K$  = hand speed constant: 1.6 m/sec (63 inches/sec) minimum based on the movement being the hand/arm only and the body being stationary

$T_s$  = worst stopping time of the machine/equipment

$T_c$  = worst stopping time of the control system

for the Design, Construction, Care and Operation of Safeguarding Standard.

Note: The calculations below are examples only and cannot be used for any specific application.

$T_r$  = response time of the safeguarding device including its interface

$T_{spm}$  = the additional stopping time, in seconds, allowed by the stopping performance monitor before it detects stop time deterioration

$D_{pf}$  = maximum travel towards the hazard within the presence sensing safeguarding devices (PSSD) field that may occur before a stop is signaled

Note:  $T_s + T_c$  are usually measured together with the ABB Jokab Safety Stop Time Analyzer.

Note:  $D_{pf}$  (depth penetration factors) will change depending on the type of device and application.

$K$  = The maximum speed at which an individual can approach the hazard, expressed in inches per second

To quote ANSI B11.19-2003: "The factor  $K$  is the speed constant and includes hand and body movements of an individual approaching a hazard area. The following factors should be considered when determining  $K$ : a) Hand and arm movement; b) Twisting of the body or shoulder, or bending at the waist; c) Walking or running.

One of the accepted values for  $K$  is the hand speed constant (it is usually considered as the horizontal motion of the hand and arm while seated). Its common value is 63 in./s although other values (typically higher) are also used. The hand speed constant does not include other body movements, which can affect the actual approach speed. Consideration of the above factors should be included when determining the speed constant for a given application."

### For Finger and Hand Detection Safety Light Curtains

$$D_{pf} \text{ in mm} = 3.4 \times (O_s - 6.875\text{mm})$$

$$D_{pf} \text{ in inches} = 3.4 \times (O_s - 0.275\text{'})$$

Where:

$O_s$  = minimum object sensitivity or resolution

### For Horizontal Mounted Safety Light Curtains

$$D_{pf} \text{ in mm} = 1200\text{mm}$$

$$D_{pf} \text{ in inches} = 48\text{'}$$

### For Multi Beam Safety Light Grids

$$D_{pf} \text{ in mm} = 1200\text{mm for a 2 beam system}$$

$$D_{pf} \text{ in inches} = 48\text{' for a 2 beam system}$$

$$D_{pf} \text{ in mm} = 900\text{mm for a 3 beam system}$$

$$D_{pf} \text{ in inches} = 36\text{' for a 3 beam system}$$



**Example 1:** With the aid of the ABB Jokab Safety Smart Stop Time Analyzer, a mechanical power press has a measured stopping time ( $T_s + T_c$ ) of 325 ms. This includes both the stopping time of the machine as well as the stopping time of the control circuit. The response time of the Focus II Safety Light Curtain FII-4-30-900 with 30mm (1.18") resolution and 900mm (35.43") protective height is 25ms ( $T_r$ ). The stop time break monitor is set for 400 ms.

In this example the Safety Light Curtain must be mounted no closer than 767.63mm (30.22") from the hazardous pinch point.



*Light Curtain as hand protection.*

$$T_{spm} = 400ms - (T_s + T_c)$$

$$T_{spm} = 400ms - 325ms$$

$$T_{spm} = 75ms$$

$$D_{pf} = 3.4 \times (30mm - 6.875mm)$$

$$D_{pf} = 3.4 \times 23.125mm$$

$$D_{pf} = 78.625mm$$

$$D_{pf} = 3.4 \times (1.18'' - 0.275'')$$

$$D_{pf} = 3.4 \times 0.905''$$

$$D_{pf} = 3.077''$$

$$D_s = [K \times (T_s + T_c + T_r + T_{spm})] + D_{pf}$$

$$D_s = [1.6m/s \times (325ms + 25ms + 75ms)] + 78.625mm$$

$$D_s = [63inch/s \times (325ms + 25ms + 75ms)] + 3.077''$$

$$D_s = [1600mm/s \times 425ms] + 78.625mm$$

$$D_s = [63inch/s \times 425ms] + 3.077''$$

$$D_s = [1600mm/s \times .425s] + 78.625$$

$$D_s = [63inch/s \times .425s] + 3.077''$$

$$D_s = 680mm + 78.625mm$$

$$D_s = 26.78'' + 3.077''$$

$$D_s = 758.63mm$$

$$D_s = 29.86''$$

**Example 2:** With the aid of the ABB Jokab Safety Smart Stop Time Analyzer, a robotic loader has a measured stopping time ( $T_s + T_c$ ) of 175 ms. This includes both the stopping time of the machine as well as the stopping time of the control circuit. The response time

In this example the horizontal Safety Light Curtain must be at least 1518.4mm (60.54") from the hazardous pinch point.



*Light Curtain as area protection.*

of the horizontally mounted Focus II Safety Light Curtain with 30mm (1.18") resolution is 29ms. The depth of penetration factor is fixed at 1200mm (48").

$$D_s = [K \times (T_s + T_c + T_r)] + D_{pf}$$

$$D_s = [1.6m/s \times (175ms + 29ms)] + 1200mm$$

$$D_s = [63inch/s \times (175ms + 29ms)] + 48''$$

$$D_s = [1600mm/s \times 204ms] + 1200mm$$

$$D_s = [63inch/s \times 204ms] + 48''$$

$$D_s = [1600mm/s \times .204s] + 1200mm$$

$$D_s = [63inch/s \times .209s] + 48''$$

$$D_s = 326.4mm + 1200mm$$

$$D_s = 12.85'' + 48''$$

$$D_s = 1526.4mm$$

$$D_s = 60.85''$$

**Example 3:** With the aid of the ABB Jokab Safety Smart Stop Time Analyzer, a transfer gantry system has a measured stopping time ( $T_s + T_c$ ) of 212 ms. This includes both the stopping time of the machine as well as the stopping time of the control circuit. The response

In this example the Safety Light Curtain must be mounted no closer than 767.63mm (30.22") from the hazardous pinch point.

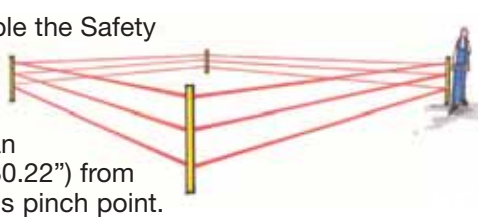

*Light Curtain for long distances.*

time of the Focus II Safety Light Grid FII-4-K4-900 is 13ms ( $T_r$ ). For a 4 beam Safety Light Grid the depth of penetration factor is fixed at 900mm (35.43").

$$D_s = [K \times (T_s + T_c + T_r)] + D_{pf}$$

$$D_s = [1.6m/s \times (212ms + 13ms)] + 900mm$$

$$D_s = [63inch/s \times (212ms + 13ms)] + 35.43''$$

$$D_s = [1600mm/s \times 227ms] + 900mm$$

$$D_s = [63inch/s \times 227ms] + 35.43''$$

$$D_s = [1600mm/s \times .227s] + 900mm$$

$$D_s = [63inch/s \times .227s] + 35.43''$$

$$D_s = 363.2mm + 900mm$$

$$D_s = 14.3'' + 35.43''$$

$$D_s = 1263.2mm$$

$$D_s = 49.73''$$

# Focus II Safety Light Curtains and Light Grids

Focus II is a new version of our previous Light Grid/Light Curtain Focus. Features such as muting and override are standard in all Focus II Light Curtains and Light Grids. For Light Curtains, blanking and break functions are also standard. The optical sensors on Focus II also have variable channel frequencies. The Focus II units are Light Curtains/ Grids with safety functions intended for applications where it is of great importance to protect persons from a dangerous machine, robot or other automated systems where it is possible to access to a dangerous area.

Focus II creates a protection field with infrared beams. If any beam is interrupted the safety mechanism is triggered and the dangerous machine is stopped. Focus II fulfills the requirements for non-contact safety equipment type 4 (Focus II series) according to the international regulation standard EN 61496-1.

Units are available with safety heights between 150 and 2400 mm. All electronic control and monitoring functions are included in the Light Curtain profiles. External connection is made via a M12 connection at the end of the profile. Synchronization between transmitter and receiver is achieved optically. No electrical connection between the units is required. Control and monitoring of the beam transmission is carried out by two micro-processors which also give information on the status and alignment of the Light Curtain via several LEDs.

## Muting and Override included in all Focus II

The “Muting” and “Override” functions are available on all Focus II Light Grids/Curtains and is enabled directly when an indication lamp LMS is connected. Muting implies that one or more segments or the whole Light Curtain can be bypassed during in and out passage of material.

In the Focus II with Muting there is also an Override function which makes it possible to bypass the Light Grid/ Curtain — i.e. activate the outputs if a machine start is necessary even if one or more Light Beams are interrupted. This is the case when the muting function is chosen and the A and B inputs are activated. If, for example, during the muting operation a loading pallet has stopped inside the safety field after a voltage loss, the override function is used to enable the pallet to be driven clear.

## Floating Blanking or Fixed Blanking

The “Floating blanking or Fixed blanking” functions are available on all Focus II Light Curtains and is enabled directly via the internal dipswitches. Floating blanking makes it possible to ‘disconnect’ a defined number of beams from the safety field. The object is then free to move in the safety field without the safety function being triggered. During “fixed blanking” the object is not able to move in the safety field. The other beams are active with normal resolution.



## Applications

Optical protection in an opening or around a risk area for —

- Mechanical and Hydraulic Power Presses
- Molding Presses
- Stamping, Riveting and Eyelet Operations
- Automated Machinery
- Robotic Cells
- Conveyors
- Material Handling Equipment
- Printing Presses
- Welding Equipment
- Machining Centers
- Packaging Machinery



## Features

- Type 4 according to EN 61496
- Flexible assembly
- LED indication
- High protection class (IP65)
- Range 3 to 40 m
- Time reset
- Floating/Fixed Blanking
- Muting
- Single/Double Break function (PSDI)
- External Device Monitoring (EDM)
- Available with different resolutions
- Up to PL e according to EN 954-1/EN ISO 13849-1

## Approvals





### Safety Outputs OSSD1 and OSSD2

Focus II has two PNP outputs—OSSD1 and OSSD2. If the load to be switched is alternating current or requires a higher current than 500 mA then one should use a safety, e.g. E1T, Pluto PLC or the FRM-1 unit (converts the outputs to relay contacts) from ABB Jokab Safety. The FMC-Tina and Tina 10A/10B/10C converts the outputs to a dynamic signal for connection to Pluto or Vital. Pluto can also work directly with the OSSD-outputs.

### Single/Double Break Function (PSDI)

This function is used for presses when the operator prepares or picks out a detail. With the Single Break function the Light Curtain allows operation after entry and withdrawal out of the curtain. Similarly, the Double Break function allows operation after entry and withdrawal twice.

### External Device Monitoring (EDM)

In all Light Grids and Light Curtains an EDM function is available which allows Focus II to test if the external

### Focus II Light Curtain

#### Standard

- Muting (bypassing) partly or completely
- Supervised output for muting lamp
- Override
- Manually supervised or automatic reset
- Time-reset
- Fixed or floating blanking
- Single/Double Break
- EDM

#### Option

- CUT – a Light Curtain cascaded with another Light Curtain. The two Light Curtains can have different resolutions.

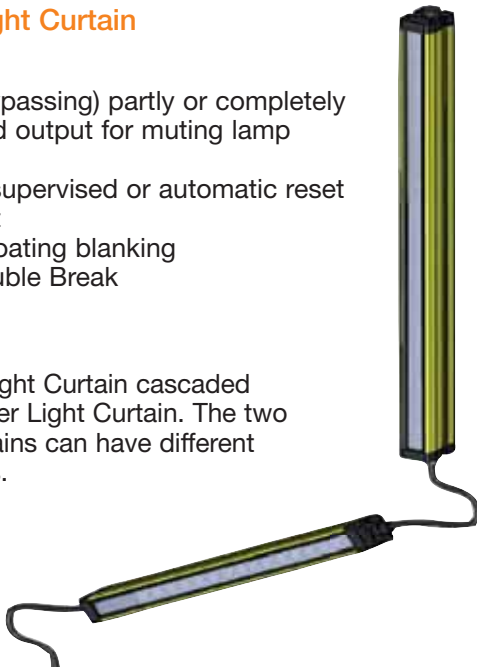

control element responds correctly. A test channel is connected through the respective contactor, in order to detect any faults and thereby prevent a reset.

### Reset

On every Focus II there are inputs for reset and other functions—Reset, Alignment and Override (bypassing is only possible when muting is used.) The reset option is chosen through dual switches in the Focus II receiver. At delivery, Focus II is set to automatic reset.

- Automatic reset – When the light field is free the outputs are closed directly. (Setting when delivered).
- Manual reset – Focus II gives a ready signal when the light field is free and the reset button has been actuated.
- Time reset – During manual reset. To reset the Focus II a pre-reset button must first be actuated and after wards within 8 seconds a reset button outside the risk area must be actuated.

*Note: For further technical information, please reference the Focus II Operating Manual.*

### Focus II Light Grid

#### Standard

- Muting (bypassing) of one, two, three or four beams
- Supervised output for muting lamp
- Override
- Manually supervised or automatic reset
- Time-reset
- EDM

#### Option

- Light Grids for tough environments with parallel beams of light for improved reliability.

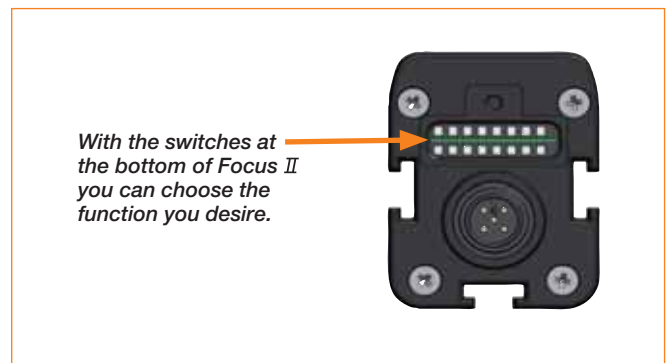

## Focus II Technical Data

Manufacturer	ABB AB/Jokab Safety, Sweden
Ordering information	see page 6:46
Supply voltage	24VDC $\pm$ 20%
Power consumption Transmitter Receiver	70 mA maximum 100 mA maximum
Safety level EN/IEC 61496 EN 954-1 EN ISO 13849-1 EN/IEC 61508	Type 4 Focus II type 4: Category 4 Focus II type 4: PL e Up to SIL 3
PFH <sub>d</sub>	$2.5 \times 10^{-9}$
Resolution	14 mm and 30 mm
Wavelength on transmitter LED	880 nm
Profile dimensions	37 x 48 mm
Protection class	IP65
Operating temperature	-10 to +55° C
Storage temperature	-25 to +70° C
Outputs	2 supervised PNP outputs with cross circuit monitoring
Max. load	500 mA (overload c.c. protection)
Response time	9 – 68 ms (depending on model)
Connection transmitter	M12 5-pin
Connection receiver	M12 8-pin
Indicator	LEDs on the transmitter and receiver indicating adjustment, dirt, power supply and outputs
Enclosure	Aluminium painted yellow
Conformity	2006/42/EG, EN/IEC 61496-1/2 EN 954-1, EN ISO 13849-1 EN/IEC 61508

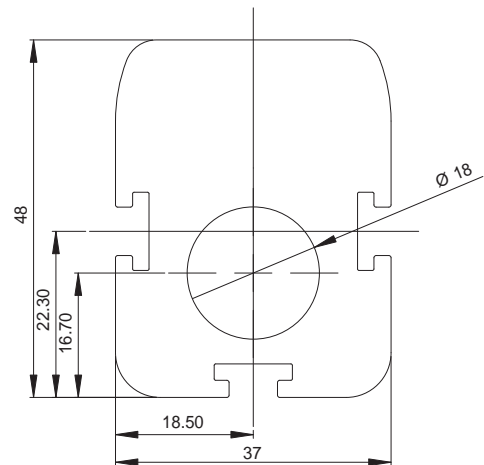

## Reset Alternatives

### Reset

On the servicing side (i.e. the side/sides where there is an operator who moves parts in and out) there shall be a separate reset function for the Light Curtain. If there are several Light Curtains (e.g. on the front and back) there shall be one for each. If the Light Curtain is actuated during a dangerous movement, the press should not be able to restart without being reset. During engagement after the end of the cycle no reset is needed.

For a Light Curtain which is placed as protection on both sides which are not servicing sides, there shall be a reset button which always needs to be activated after an engagement.

### Supervised Manual Reset

When a Light Curtain/Light Grid is interrupted it will give a stop signal to dangerous machines within the risk area it protects. For a new start of the machine the Light Curtain/Light Grid has to be reset. This is done with the reset button (Figure 1) which is placed where it cannot be reached from within the area which is protected. There are high requirements on the reset function — neither a short circuit nor a component fault shall give automatic reset. When the reset button has been affected the outputs are activated and the machine can initiate.

### Automatic Reset

Automatic reset can only be used when it is impossible to get between the Safety Light Curtain and the hazardous pinch point. When the operator removes his hands from the protective field the dual safety outputs will energize starting the next machine cycle immediately. (Figure 2)

### Pre-Reset Solution

If the machine start button is not located such that you have a clear view of the entire work area, additional safe guards must be used. Typical devices include Safety Laser Scanners, Safety Mats and Horizontal Safety Light Curtains.

Focus II Safety Light Curtains address this requirement without costly additional safety devices. By selecting the Pre-Reset mode through the Focus II Receiver's internal dipswitches, the primary requirement for accidental resets is satisfied. The Pre-Reset must first be cycled, which gives a clear view of the work area, then no longer than 8 seconds later the Final Reset must be cycled.

Figure 1  
Reset button  
with light indication.

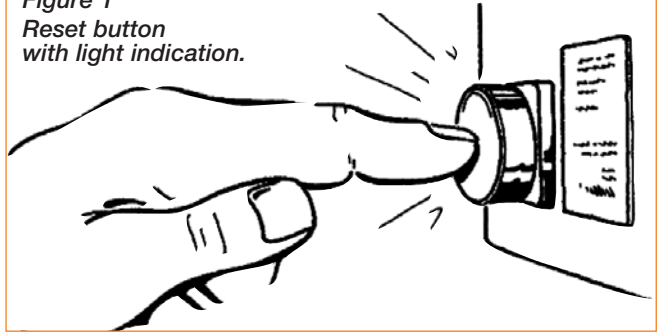
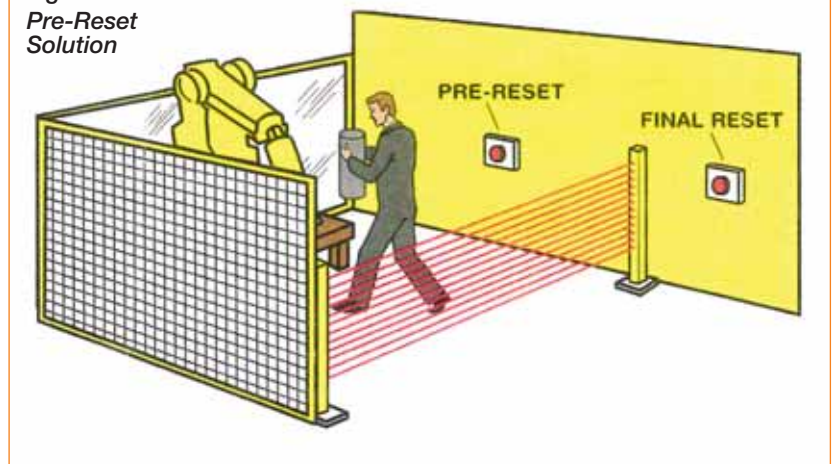

Figure 2  
Automatic  
Reset



Figure 3  
Pre-Reset  
Solution



## Mounting Focus II Light Curtains and Light Grids

### Vertical Safety Light Curtains

A vertically mounted Safety Light Curtain that is used as the primary safety device must be mounted so that the bottom beam is no higher than 300mm (12") from the ground. Mounting heights above 300mm (12") may require supplemental safeguarding to prevent crawling or ducking under the horizontal Light Curtain. The top beam must be no lower than 900mm for reach over applications and 1200mm (48") for reach through applications. Mounting heights lower than this will require additional safeguarding.



### Horizontal Safety Light Curtains

A horizontal Safety Light Curtain that is used as the primary safety device must be mounted no higher than 300mm (12") from the ground. Mounting heights above 300mm (12") may require supplemental safeguarding to prevent crawling or ducking under the horizontal Light Curtain. The minimal length the Safety Light Curtain can be 1200mm (48") long.

The formula below is for mounting different resolutions from a horizontal surface.

$$\text{Height} = 15 \times (\text{Os} - 50\text{mm})$$

$$\text{Height} = 15 \times (\text{Os} - 2")$$

*Note: Os represents the beam spacing.*



### Vertical Perimeter Safety Light Grids

A vertically mounted Safety Light Grid must be mounted such that the bottom beam is no higher than 300mm (12") from the ground.

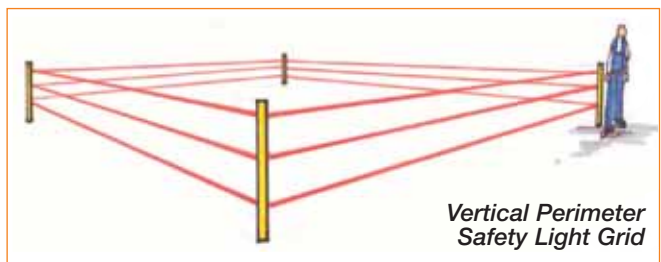

## Muting (Bypassing)

Bypassing may be needed for different reasons. One of the most common reasons for bypassing is during in and out feeding of material on a conveyor, auto industrial trucks, etc. Another common application is bypassing while passing with a three-position device to the risk area.

Important aspects for bypassing are that it should be safe, not be activated by mistake and be difficult to defeat. In other words, it should give a reliable bypassing when a loading carrier comes but not allow a human to pass. To achieve the highest safety level a dual and supervised bypassing system is needed—usually with at least two independent signals.

To avoid deliberate defeating/manipulation of the bypassing sensors/signals a safety relay or a safety PLC is connected, thereby monitoring that both sensors are activated and deactivated in every bypassing cycle. This monitoring is built into Focus II.

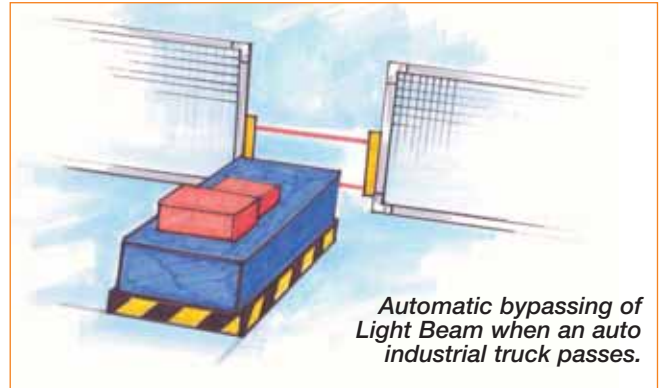

*Automatic bypassing of Light Beam when an auto industrial truck passes.*

The amount of variants of bypassing systems are almost infinite, depending on the specific requirements of each plant/machine. For Focus II there are a number of bypassing possibilities prepared.

## Examples on how the Muting Sensors can be placed

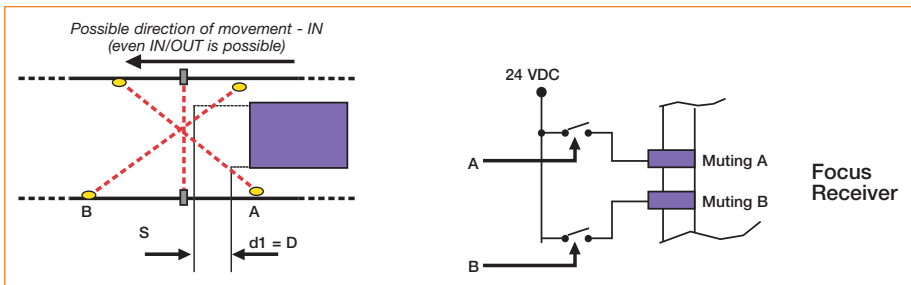

*A solution with two sensors (photocells shown) and ONE (or TWO) movement directions for material transport.*

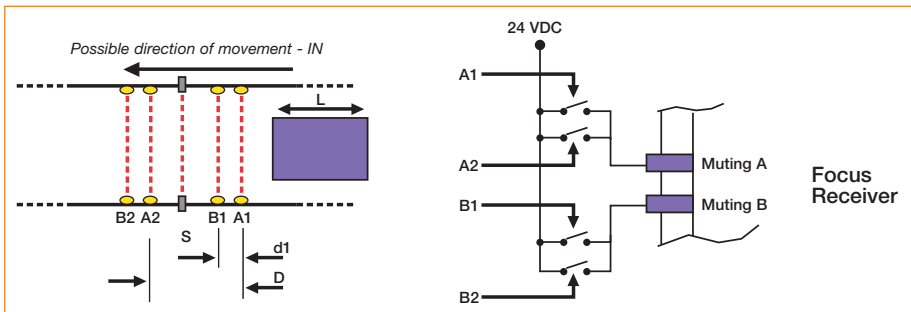

*A solution with four sensors and ONE movement direction for material transport.*

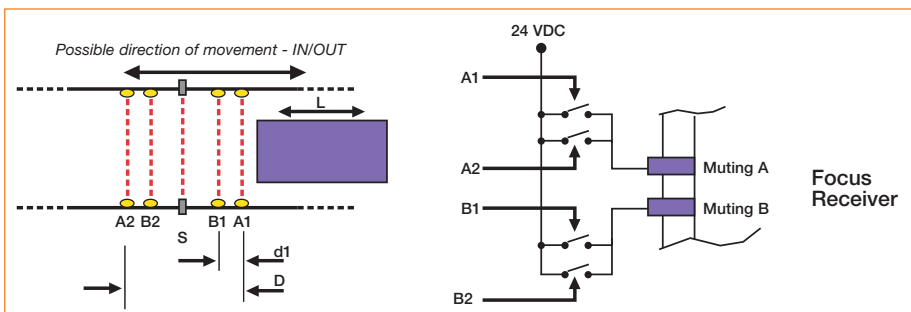

*A solution with four sensors and TWO movement directions for material transport.*

## Cycle Initiation with Light Curtain (PSDI)

### Cycle Initiation

Cycle initiation is a concept when the machine is designed so that a new cycle starts when you take your hand out from the Light Curtain. A cycle is defined as the hand being placed in and taken out once. Usually it is possible to choose between one-cycle and two-cycle operation. During one-cycle a new press stroke is started when the Light Curtain has been actuated once and during two-cycle when the Light Curtain has been actuated twice. The operator thereby operates the press by the action of putting parts in and out.

Because the press starts without any particular command there are some risks involved and therefore many conditions have to be met before the machine operates.

To restrict the usage to smaller presses which cannot be entered there are the following limitations: The table height may not be lower than 750 mm, the stroking length may not be larger than 600 mm and the table depth may not be larger than 1000 mm. The Light Curtain shall have 30 mm or higher resolution. If the press is not started within approx. 30 seconds after the end of the cycle, a new cycle should not be accepted without the Light Beam being again manually reset.

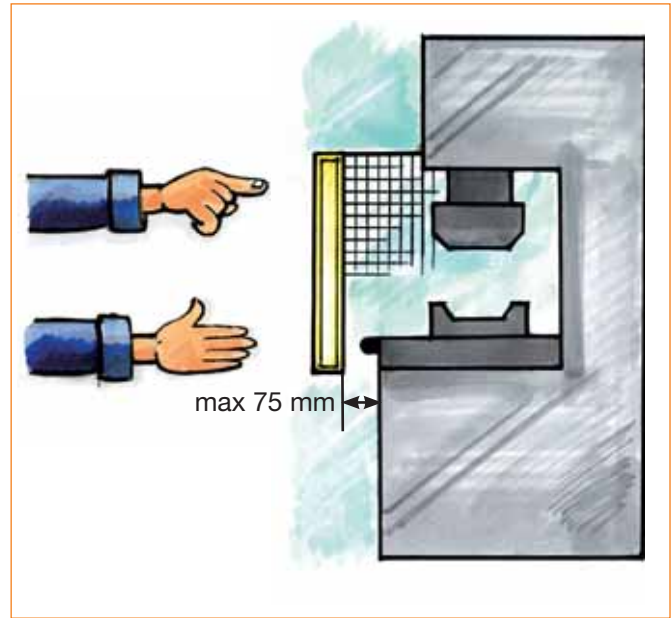

*Note. For machines with cycle initiation, the installation of the Light Curtain must be in accordance with machine parameters and all relevant standards and regulations.*

### Installation of Light Curtain

The Light Curtain must be installed so no-one can reach a trapping/crushing risk without actuating the Light Curtain. The most important thing is that there are no gaps under, on the sides and over the top during cycle operation. The lower edge of the Light Curtain must therefore be slightly below the press table edge. Also if it is open above the Light Curtain the height must be adapted so that it is not possible to reach over the protection area (see ISO 13855). Possible physical adjustment possibilities must be limited so that no gaps can occur.

Between the Light Curtains protection area and mechanical parts there shall only be max 75 mm gap to prevent a human from standing there. In practise to achieve this demand and the required safety distance one usually has to complement with e.g. additional mechanical protection or additional horizontally positioned Light Curtains i.e. step-in Light Curtain. Another solution could be a lying or an angled Light Curtain.

### Correct and Incorrect Installation



#### Correctly Installed

*The operator cannot reach into the machine without actuating Light Curtain.*



#### Incorrect Installation

*Gap below Light Curtain. The operator can reach into the machine without actuating the Light Curtain.*



#### Incorrect Installation

*Gap above Light Curtain. The operator can reach into the machine without actuating Light Curtain.*



#### Correctly Installed

*Light Curtain complemented with a horizontal Light Curtain to detect the operator.*

## Muting with FMC and FMI Units

The FMC Focus Muting Connector is a small, optimal unit which is used when the Focus II Light Curtain or Light Grid is required to be bypassed for in and out passage to and from a dangerous area. The FMC unit is easily connected to Focus II with an M12 connector.

The FMI Focus Muting Indicator is a small unit with built-in muting lamp, reset button, "power off" (for alignment and override). The FMI unit is connected to the FMC unit with M12 connectors to facilitate the muting function connection.



## Various FMC, FMI, FRM Versions and Tina Units

<p><b>FMC-1</b> 2TLA022 042R0000</p> <p>M12-8</p>	<p><b>FMC-2</b> 2TLA022 042R1000</p> <p>-8</p>	<p><b>FMI-1A</b> 2TLA022 043R0000</p> <p>Muting Lamp</p> <p>LMS</p> <p>Reset</p> <p>Power Off</p> <p>-5</p>	<p><b>FMI-1B</b> 2TLA022 043R0100</p> <p>Reset</p> <p>Power Off</p> <p>-5</p>	<p><b>FMI-1C</b> 2TLA022 043R0200</p> <p>Reset</p> <p>Power Off</p> <p>-5</p>	<p><b>FMI-1D</b> 2TLA022 043R0300</p> <p>Reset</p> <p>Power Off</p> <p>-5</p>	<p><b>JS SP-1</b> 2TLA022 070R0000</p>	<p><b>JS AP-1</b> 2TLA022 070R1000</p>	<p><b>FMC-1(2):</b> With connectors for muting sensors (A+B), reset, power off and muting lamp (R) and muting lamp (M).</p> <p><b>FMI-1A:</b> With muting lamp only.</p> <p><b>FMI-1B:</b> With reset, power off and muting lamp.</p> <p><b>FMI-1C:</b> with reset and power off.</p> <p><b>FMI-1D:</b> With reset, power off and internal resistor for the muting lamp.</p> <p><b>FMI-1E:</b> As pre reset connected to connector A (A2) on FMC-1(2) (Tina).</p> <p><b>FMI-1G:</b> With reset, and internal resistor for the muting lamp.</p>
<p><b>FMC-1 Tina</b> 2TLA022 045R0000</p> <p>M12-8</p>	<p><b>FMC-2 Tina</b> 2TLA022 046R0000</p> <p>-8</p>	<p><b>Tina 10A</b> 2TLA022 054R1200</p> <p>2</p> <p>1 3</p> <p>-5</p>	<p><b>Tina 10C</b> 2TLA022 054R1500</p> <p>2</p> <p>1 3</p> <p>-5</p>	<p><b>FRM-1A</b> 2TLA022 048R0000</p> <p>Reset</p> <p>-8</p>	<p><b>FMI-1E</b> 2TLA022 043R0400</p> <p>Reset</p> <p>-5</p>	<p><b>FMI-1G</b> 2TLA022 043R0500</p> <p>Reset</p> <p>-5</p>	<p><b>FMC-1 (2) Tina:</b> The same as FMC-1(2) but made for connecting to Vital or Pluto.</p> <p><b>Tina 10A:</b> Adaptor unit for connecting Focus to Vital or Pluto.</p> <p><b>Tina 10B:</b> Simplified FMC-1(2) Tina but with only the (R) connector.</p> <p><b>Tina 10C:</b> Simplified FMC-1(2) Tina but with only power feed at connector #3.</p> <p><b>M12-3M</b> Bypass unit for easy connection outside the enclosure</p> <p><b>FRM-1A:</b> Converts the two OSSD outputs to relay outputs (and power feed)</p> <p><b>JS SP-1:</b> Blanking plug for unused inputs</p> <p><b>JS AP-1:</b> Adaptor for FMC units to use without FMI-1B or FMI-1D at (R) connector with muting resistor</p>	
<p><b>Tina 10B</b> 2TLA022 054R1300</p> <p>2</p> <p>1 3</p> <p>-5</p>	<p><b>M12-3M</b> 2TLA022 055R0400</p> <p>2</p> <p>2 3</p> <p>1</p> <p>-5</p>							

## M12 Connection Device with Screw Connectors

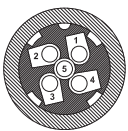

M12-C01 (Female)



M12-C02 (Male)

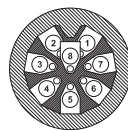

M12-C03 (Female)

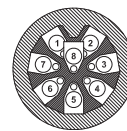

M12-C04 (Male)



Note: Connector drawings are shown from cable side.

## Connection of Focus II and Muting Components with FMC1 and FMI1

Connection of Light Curtain with connection block FMC 1, text/reset button 1 and switch for supply voltage placed in or by the control cabinet.

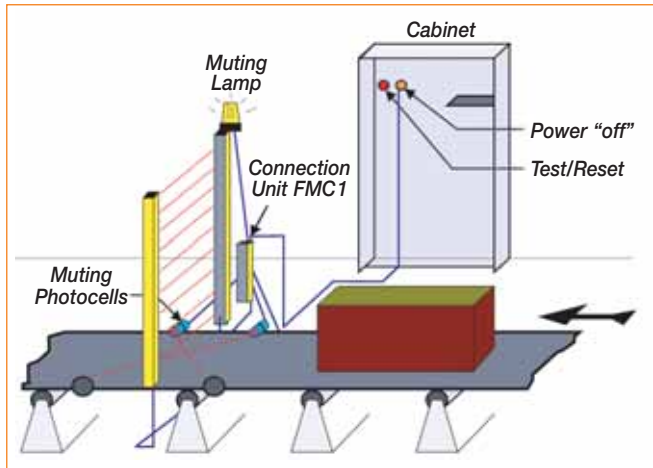

Connection of Light Curtain with connection block FMC1. The FMI reset unit must be placed out of reach from the risk area.

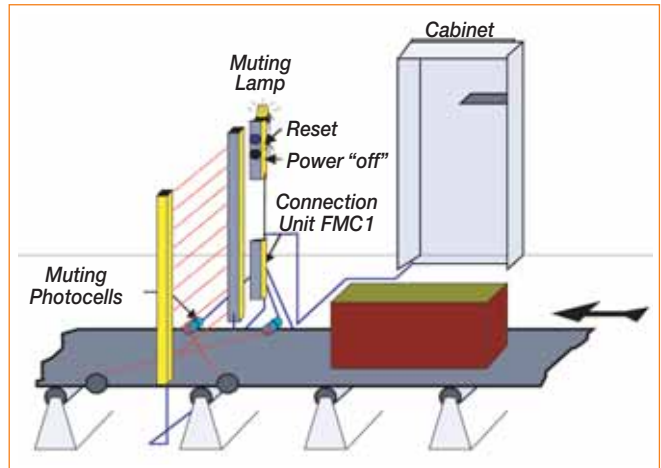

## Connection of Focus II and Muting Components directly to Control Cabinet

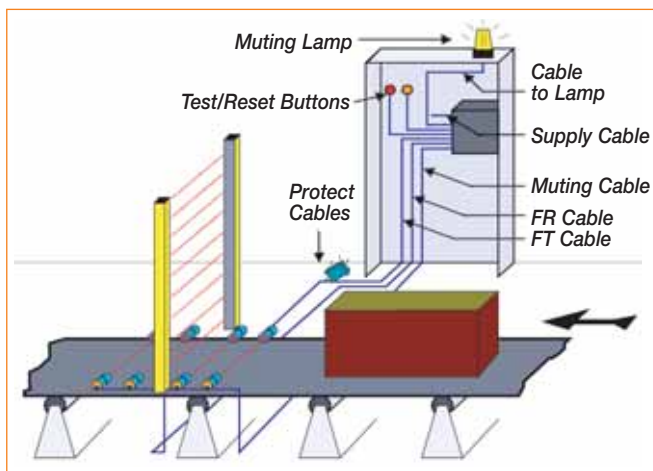

The test/reset button shall be placed so the operator can see the protected area during reset, testing and bypassing. It should not be possible to reach the button from within the risk area.

The LMS lamp for indication of muting and bypassing shall be placed so that it can be seen from all directions from where it is possible to access the dangerous area.

If photocells are used as muting sensors, the sensor receivers should be assembled on the Light Curtain's transmitter side to minimize the interference risk.

The system is protected against dangerous functions caused by damage on the transmitter cable and/or the receiver cable. However, we recommend that the cables be protected so that physical damage to them can be minimized.

## Focus II Modular Muting Capabilities

The Focus II Safety Light Curtain offers the selection of complete muting of the protective field during the in and out passage of material. Through dipswitch settings in the Focus standard version, it is also capable of muting only specific modules within the protective field.

The Focus II is capable of muting independent beam module packets or a combination of them (up

to 4). For example, a box travels down a conveyor and instead of muting the entire Light Curtain you can mute only modules 1 and 2—which equates to the height of the box—allowing continual protection on the remaining Safety Light Curtain modules.

The module size is directly dependent on the Focus II Light Curtain resolution and length.



## Muting with MFII-T/MFII-L Units

MFII-T and MFII-L are muting units with integrated photocells in the same profile type as the Focus II Light Curtain/Grid. No additional sensors are required because the muting units contain the required components. MFII-T/MFII-L is connected directly to Focus II with M12 connectors.

### MFII-T (Option 1)

MFII-T contains four photocells—A1, B1, B2 and A2—arranged as shown. they are configured for installations where material is transported “in” or “out”—or in both directions “in and out”.

### MFII-L (Option 2)

MFII-L contains two photocells—A1 and B1—which are actuated before and by material exiting through the Light Curtain/Grid. The Light Curtain/Grid remains bypassed just prior to the exit of the material.

*Note: MFII-L is primarily intended for material transport “out” of a working area.*

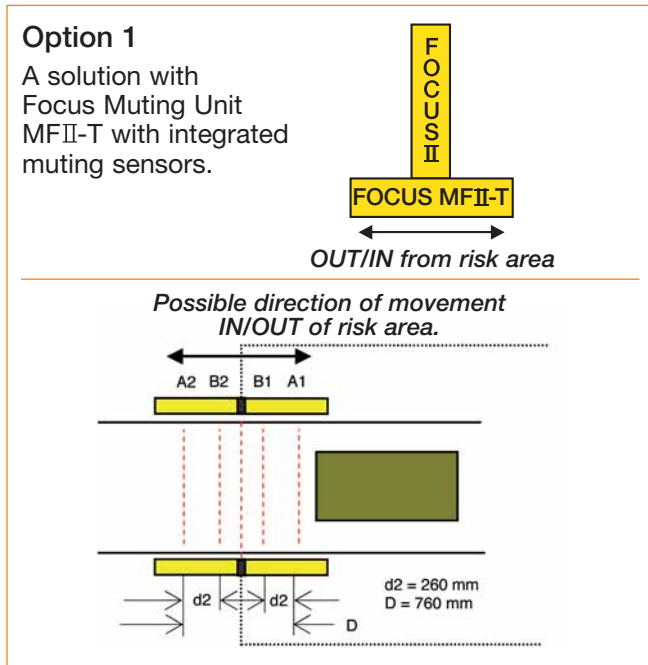
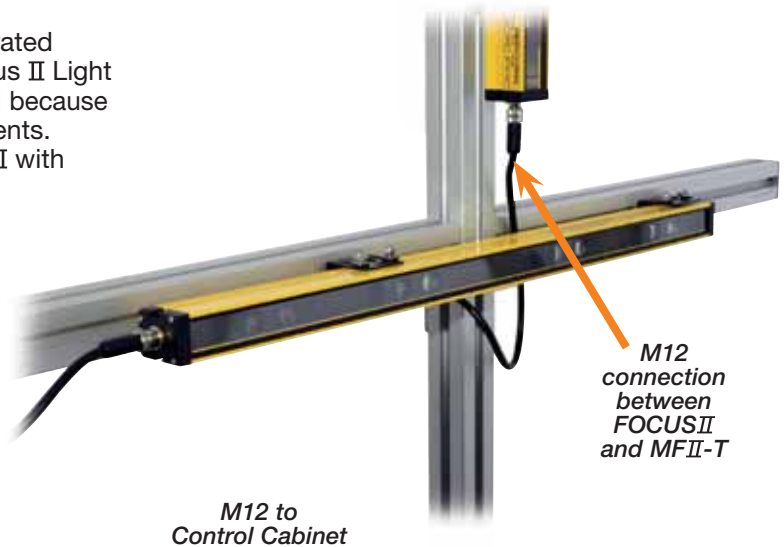

*Note: The muting sensors A and B must be placed so that the sensor A is always activated at least 30 ms before sensor B.*

*D: indicates the minimum length of the material that is to actuate the muting sensors that must be maintained during the passage through the Light Curtain/grid.*

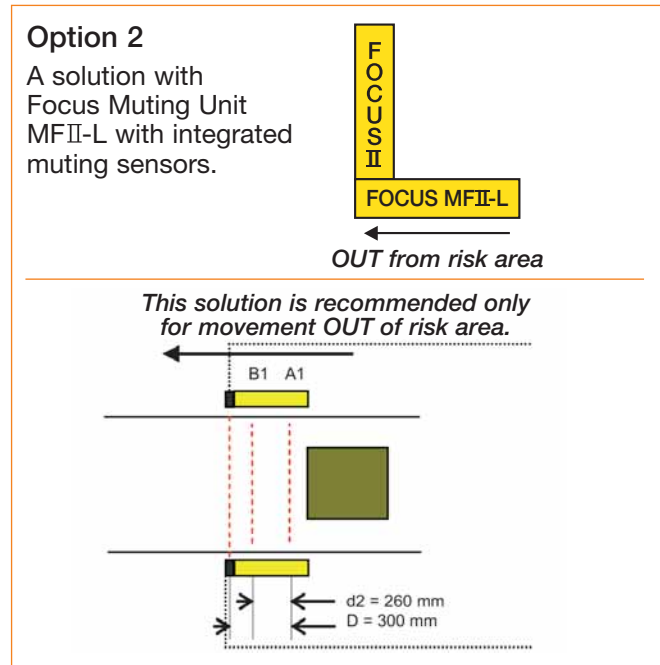

*d2: indicates the measurement between the two preassembled muting sensors within the MFII-T and MFII-L.*

## Muting with MFII-T Reflex/MFII-L Reflex Units

MFII-T Reflex and MFII-L Reflex are muting units with integrated retro-reflective photocells in the same profile type as the Focus Light Curtain/Grid. No additional sensors are required because the muting units contain the required components. The Reflex series simplifies the set up of muting sensors, as only 1 side requires a cable connection. The reflective side is a polarized reflector bar. MFII-T Reflex and MFII-L Reflex are connected directly to the Focus Receiver with M12 connectors.

### MFII-T Reflex (Option 3)

MFII-T Reflex contains four transmitters/receivers and a separate reflector unit. Range 6m. Used in the muting mode for transport of material into and/or out of hazardous areas. For other functions refer to Option 1. This unit, together with Light Beam FII-4-K1C-500 provides electrical connections on only one side.

### MFII-L Reflex (Option 4)

MFII-L Reflex contains two transmitters/receivers and a separate reflector unit. Range 6m. Used in the muting mode for transport of material into or out of hazardous areas. For other functions refer to Option 2. This unit, together with Light Beam FII-4-K1C-500 provides electrical connections on only one side.

*Note: MFII-L Reflex unit is primarily intended for material transport "out" of a working area.*

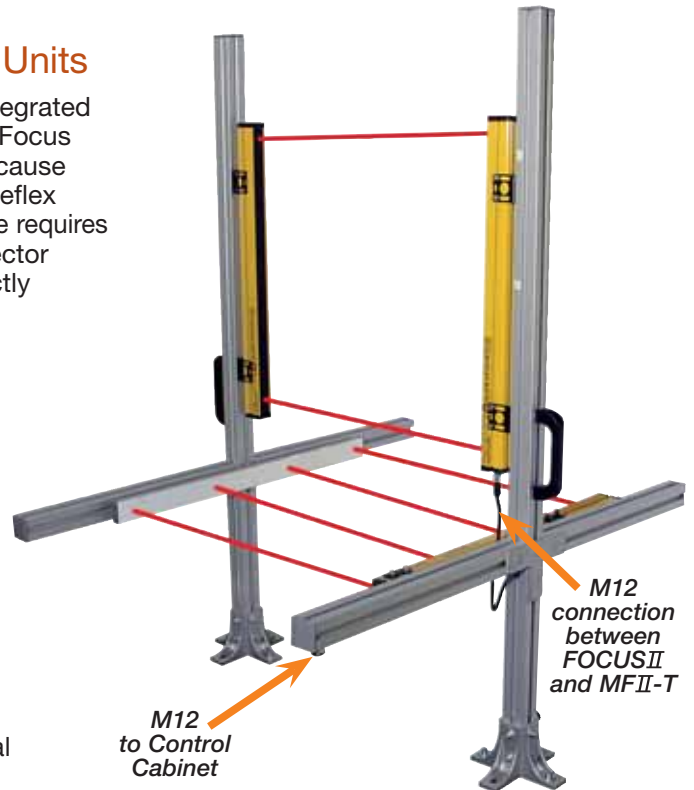

#### Option 3

A solution with Focus Muting Unit MFII-T Reflex with integrated retroreflective muting sensors.

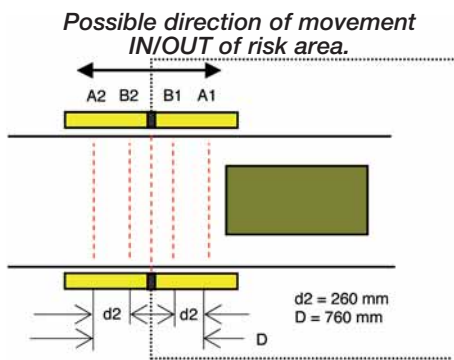
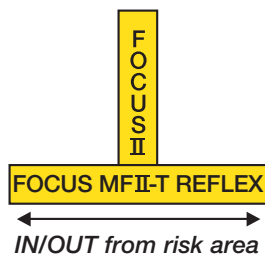

*Note: The muting sensors A and B must be placed so that the sensor A is always activated at least 30 ms before sensor B.*

*D: indicates the minimum length of the material that is to actuate the muting sensors that must be maintained during the passage through the Light Curtain/grid.*

#### Option 4

A solution with Focus Muting Unit MFII-L Reflex with integrated retroreflective muting sensors.

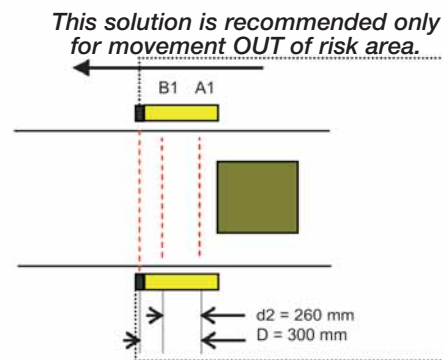
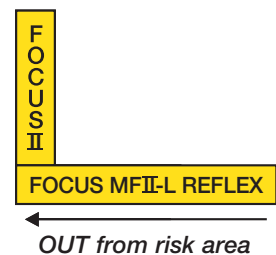

*d2: indicates the measurement between the two preassembled muting sensors within the MFII-T Reflex and MFII-L Reflex (= 150mm).*

## Focus II Type 4 (FII-4) Summary

Note: For ordering information see the components list beginning on page 6:39. For more information visit [www.jokabsafetyna.com](http://www.jokabsafetyna.com)

Type 4	FII-4-14-zzzz	FII-4-30-zzzz	FII-4-K4-zzzz		FII-4-K3-800	FII-4-K2-500
Resolution	14	30	300	400	400	500
Height (mm=zzzz)	150 300 450 600 750 900 1050 1200 1350 1500 1650 1800 1950 2100 2250 2400	150 300 450 600 750 900 1050 1200 1350 1500 1650 1800 1950 2100 2250 2400	900	1200	800	500
Range (m) SR LR	0.2-3 3-6	0.2-7 7-14	0.5-20 20-40		0.5-20 20-40	0.5-20 20-40
Reaction time off (ms)	12-68	9-31	13		13	13
Reaction time on (ms)	138-104	141-119	142		142	142
Manual reset	•	•	•		•	•
Automatic reset	•	•	•		•	•
Pre reset	•	•	•		•	•
Muting inputs	•	•	•		•	•
Muting lamp supervision	•	•	•		•	•
Override	•	•	•		•	•
Muting T/L/X	• / • / •	• / • / •	• / • / •		• / • / •	• / • / •
Blanking 3 types	• / • / •	• / • / •	- / - / -		- / - / -	- / - / -
Single/Double break	• / •	• / •	- / -		- / -	- / -
EDM	•	•	•		•	•
Dyn. Adaption to Vital/Pluto	☐	☐	☐		☐	☐

• Standard

☐ With Tina 10A/10B/10C or FMC\_Tina.

## Focus II Type 4 (FII-4) Summary (continued)

Note: For ordering information see the components list beginning on page 6:39. For more information visit [www.jokabsafety.com](http://www.jokabsafety.com)

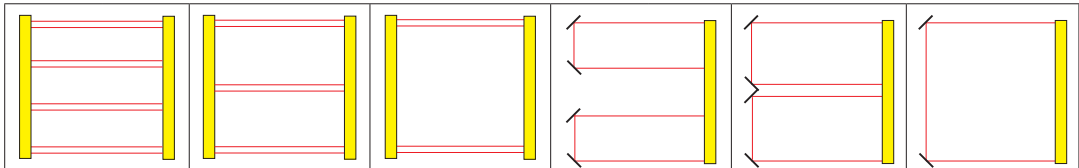

Type 4	FII-4-K4-zzzz D		FII-4-K3-800 D	FII-4-K2-500 D	FII-4-K2C-zzzz		FII-4-K2C-800	FII-4-K1C-500
Resolution	300	400	400	500	300	400	800	500
Height (mm=zzzz)	900	1200	800	500	900	1200	800	500
Range (m) SR LR	0.5-20 20-40		0.5-20 20-40	0.5-20 20-40	0.5-7		0.5-8	0.5-12
Reaction time off (ms)	13		13	13	13		13	13
Reaction time on (ms)	142		142	142	142		142	142
Manual reset	•		•	•	•		•	•
Automatic reset	•		•	•	•		•	•
Pre reset	•		•	•	•		•	•
Muting inputs	•		•	•	•		•	•
Muting lamp supervision	•		•	•	•		•	•
Override	•		•	•	•		•	•
Muting T/L/X	• / • / •		• / • / •	• / • / •	• / • / •		• / • / •	• / • / •
Blanking 3 types	- / - / -		- / - / -	- / - / -	- / - / -		- / - / -	- / - / -
Single/Double break	- / -		- / -	- / -	- / -		- / -	- / -
EDM	•		•	•	•		•	•
Dyn. Adaption to Vital/Pluto	☐		☐	☐	☐		☐	☐

• Standard

☐ With Tina 10A/10B/10C or FMC\_Tina.

# Bjorn Stand System for Light Grids and Mirrors

Bjorn is a very stable and flexible stand system in which Focus II Safety Light Beams and Mirrors are mounted in the stand. The hardware for the mirrors in the stand can be turned to provide either vertical or horizontal angles. The robust material of the Bjorn protects Focus II units from direct collisions, thus preventing unnecessary material damage and halts in production.

## Applications

- Protects mirrors and Light Beams

## Features

- Robust
- Adjustable



## Bjorn Technical Data

Manufacturer	ABB/Jokab Safety, North America
Ordering information	see page 6:39
Color	Yellow powder-coated (RAL 1018)
Material	3 mm steel
Dimensions Cross section Foot	146 mm x 130 mm 230 mm x 190 mm
Weight H2, V2 and N2 H3 H4-1, H4-2 N5	15 kg/piece 17 kg/piece 20 kg/piece 27 kg/piece
Mirror reduction	≤10 %

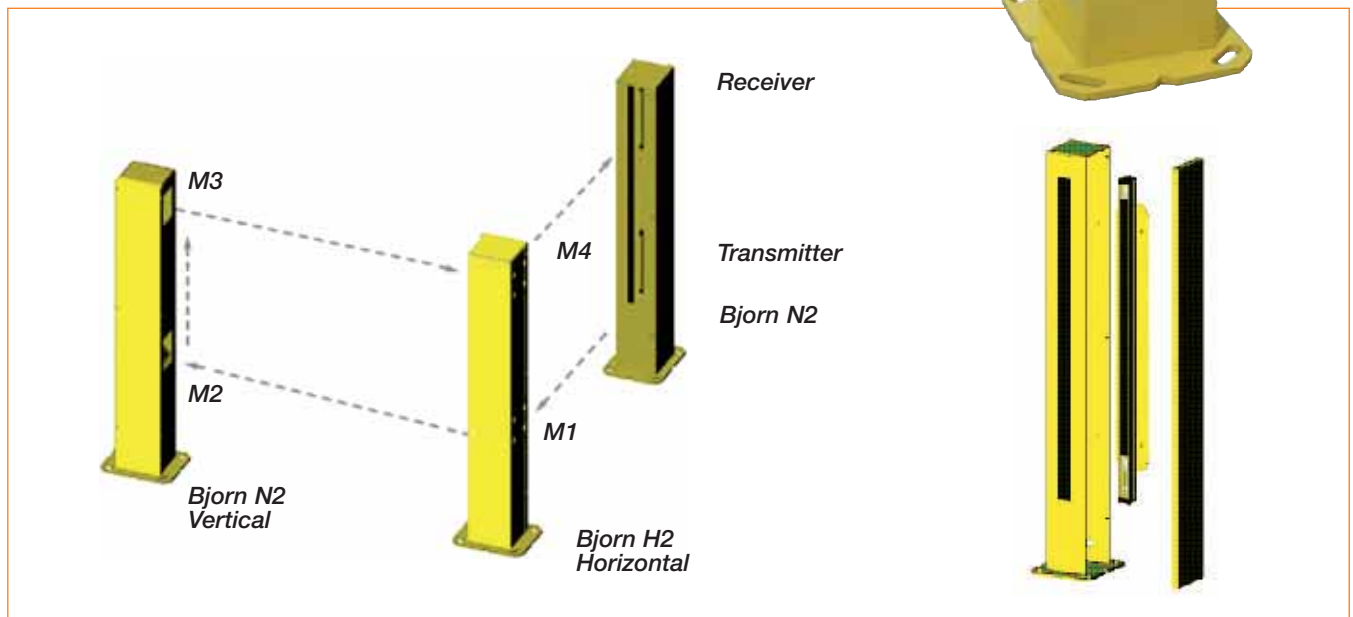

# Bjorn Dimensions

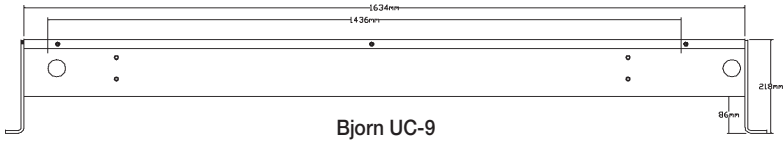
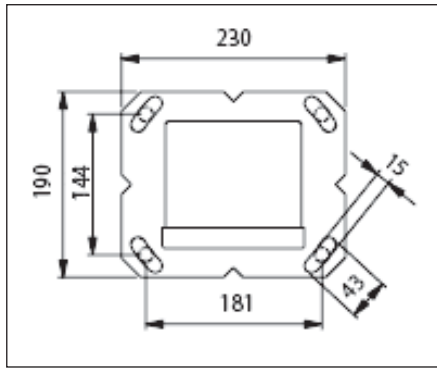

Bjorn UC-9

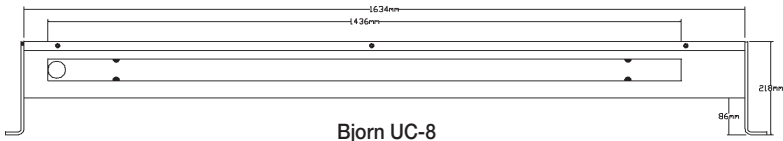

Bjorn UC-8

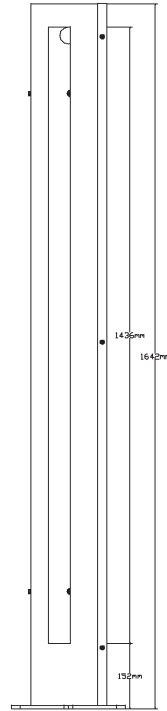

Bjorn UC-10

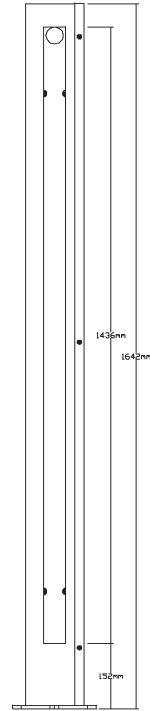

Bjorn UC-3

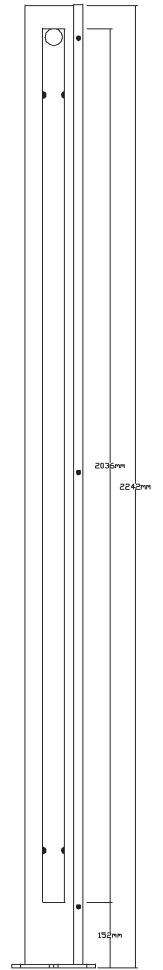

Bjorn UC-4

# Wet Wash Down Tubes for Protection against Water and Dust

Wet Wash Down Tubes are used for protection against water (or dust) where extreme washing conditions are encountered. The protective encapsulation rating (IP68) now enables Focus II Light Curtains and Light Beams to be used for such applications as the food industry, where the use of high pressure washing for cleaning machinery often occurs. The draining and through ventilation capabilities mean that condensation can be avoided.

Wet, with Focus II Light Curtains/Beams, is pre-assembled complete with cabling on request. During installation on a machine, a Wet unit can be adjusted by +/- 20° with the accompanying angle bracket. The plastic tube is rotatable and the outside is easy to clean.

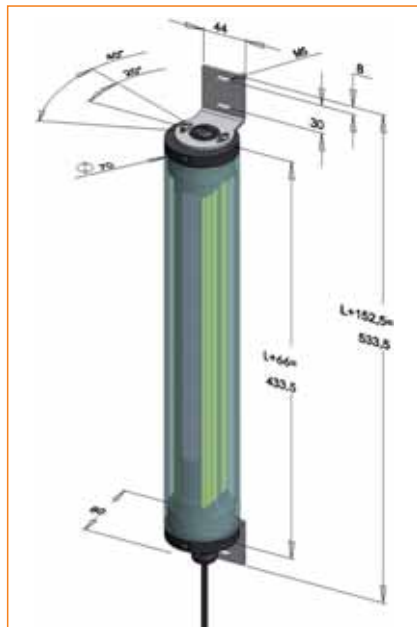

## Applications

- Protection in severe environments

## Features

- Adjustable +/-20°
- Rotatable and replaceable
- Capable of draining and through ventilation



## Wet Technical Data

Manufacturer	ABB AB/Jokab Safety, Sweden
Ordering information	see page 6:40
Color	Transparent plastic
Length including lid	light curtain/Light Beam + 66 mm
Material	
Tube	PC
Lid	PEHD-300
Angle bracket	Stainless steel
Max. ambient temperature	+55°C
Installation adjustment	± 20°
Protection rating	IP68 (IP69K)

# Spot Safety Light Beam for the Highest Level of Safety

The Light Beam is available in two versions—Spot 10 for distances up to 10 m and Spot 35 for up to 35 m. The Light Beams can be mounted at different heights and be angled around a machine using our mirrors and brackets.

Spot and Vital in combination fulfills the requirements for Category 4 according to EN-954-1/EN ISO 13849-1 and type 4 according to EN 61496. Several Light Beams, Eden sensors and Emergency Stops can be connected in series achieving the high safety level for the safety circuit. A number of solutions for bypassing of Light Beams for material transport are available.

For indication there are LEDs on the transmitter and on the receiver which indicate 'contact' between transmitter and receiver and safety status. The 'contact' information is available via the Light Beam receiver connection cables.

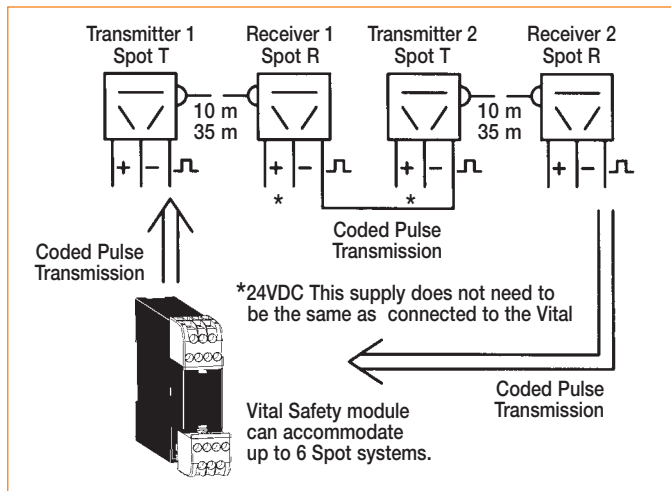

## Function

The Spot Light Beam is supervised by the Vital Safety Module. A unique coded signal is sent out from the control unit (Vital) to the transmitter (Spot T). The signal which comes back from the receiver (Spot R) is then compared in the Vital. If the correct coded signal is received the Vital switches the necessary safety output contacts to permit dangerous machine movements. Coding guarantees that no output signals can be produced by light from other sources, interference or faults in components in the transmitter or receiver. The Light Beam is dynamically supervised which means that if the signal stops pulsating at the correct frequency it is immediately detected. By using this special code function in the sensors, the signal can travel via up to 6 transmitter/receiver pairs which are not electrically connected to the Vital unit.



## Applications

- Photoelectric guarding of an entrance or around a risk area

## Features

- Safety level type 4 according to EN 61496
- Versatile mounting
- LED indication
- Protection class IP67
- 10 m or 35 m range
- Bypassing possibility
- Can be connected with several other different safety devices in the same safety circuit at category 4 together with Vital according to EN ISO 13849-1.

## Approvals

TÜV Nord  



## Spot Mounting and Alignment

### Safety Distance

The basic principle is that dangerous machine movements should be stopped before a person reaches the dangerous area, which should be at least 1200 mm from the Light Beams. When determining the correct safety distance the stopping time of the machine and the risk level must be taken into account (see also EN 999). Contact us for further information.

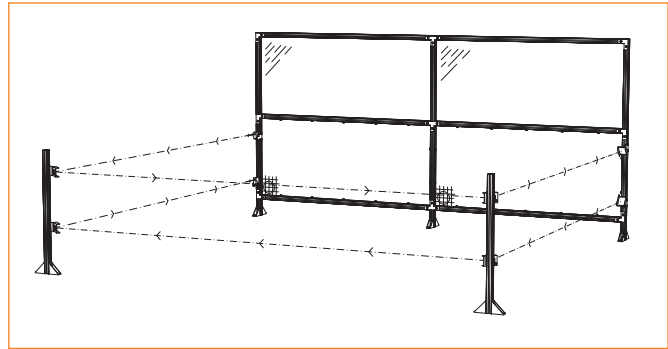

### Accessories and Mounting

The Spot Light Beam can be mounted using a variety of brackets, posts and mirrors. See component list for further information.

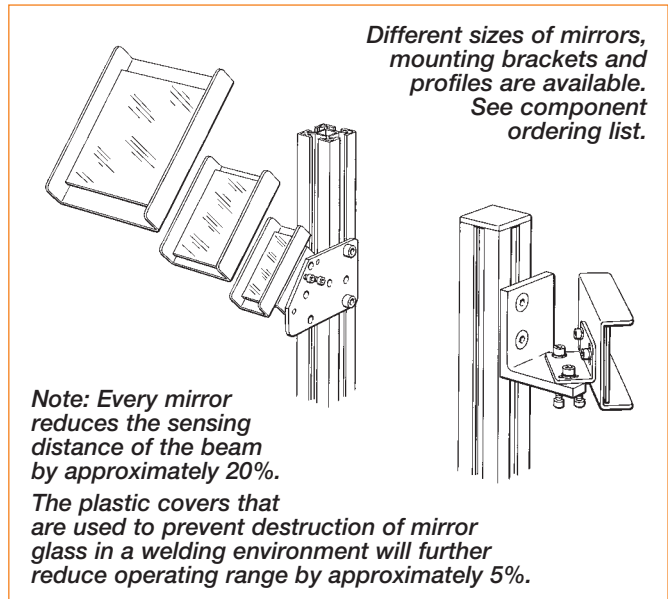
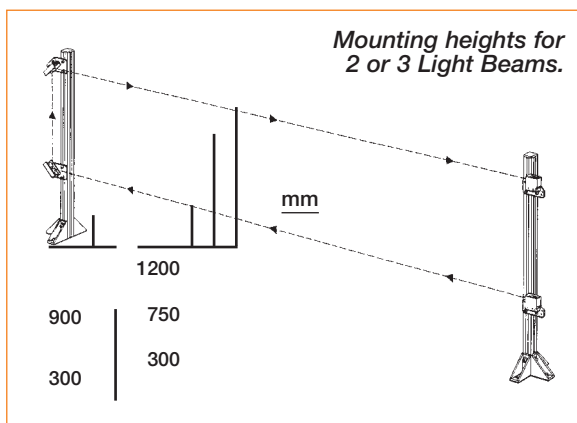

### Alignment

When aligning the Light Beam, look towards the transmitter. In the lens will be seen a strong red light. When this light is seen from the receiver (via mirrors if fitted) the Light Beam is basically aligned. The LED on the receiver is on when the receiver is aligned with the transmitter. By moving the transmitter up/down and left/right the best alignment can be found.

When vertically mounting, (as shown in the diagram) the receiver should be mounted above the transmitter as this will simplify the alignment and minimize the risk of extraneous light disturbance. In exceptional light disturbance environments the received light can be adjusted by a screw on the rear of the Spot 35 receiver. On Spot 10 this adjustment can be made on the transmitter. To make the alignment even easier the Laser Aligner (JSRL2) can be used for Spot 35. The laser has visible light (class IIa) and is easy to mount for aligning. Supply to the Laser Aligner is taken from the Spot 35 T/R connector.

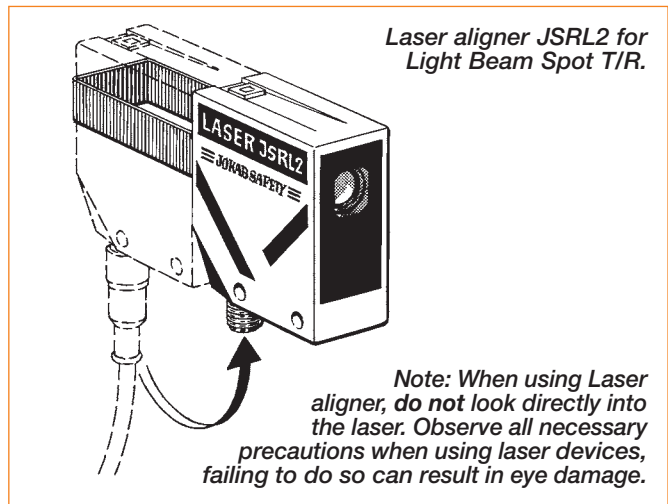

## Spot Technical Data

<b>Manufacturer</b>	ABB Jokab Safety, Sweden
<b>Ordering information</b>	see page 6:40
<b>Safety level</b> EN/IEC 61496 EN 954-1 EN ISO 13849-1	Type 4 with Vital/Pluto Category 4 PL e
<b>PFH<sub>d</sub></b>	1.14x10 <sup>-8</sup>
<b>Power supply</b>	17 – 27 VDC, ripple ±10%
<b>Current consumption</b>	
Transmitter	< 25 mA
Receiver	< 15 mA
<b>Output currents</b>	
Info. output	10 mA max.
Dynamic signal out	30 mA max.
<b>Light source</b>	Red visible light, 660 nm, <±2°
<b>Optical power</b>	
Spot 10	< 0.1 mW
Spot 35	< 0.2 mW
<b>Function indication</b>	
Green LED on transmitter (power)	Power supply OK
Green LED on receiver status	
On	Alignment OK, safety circuit closed
Flashing	Align. OK, earlier safety circuit open
Off	Beam interrupted, safety circuit open
<b>Protection class</b>	IP 67
<b>Range</b>	
Spot 10	0 - 10 m
Spot 35	0 - 35 m
<b>Range adjustment</b>	
Spot 10	Trim pot. on transmitter
Spot 35	Trim pot. on receiver
<b>Installation</b>	
Spot 10	2xM18 nuts (provided)
Spot 35	Either via mounting holes in the casing or with angle bracket JSM63 (provided)
<b>Operating temp. range</b>	-25°C – +65°C
<b>Cable connection</b>	M12 fixed connector
<b>Casing Material</b>	
Spot 10	Steel housing with polyacryl lens protection
Spot 35	Polyamide housing with polyacryl lens protection

<b>Color</b>	
Spot 10	Steel grey
Spot 35	Yellow and black
<b>Weight</b>	
Spot 10	2 x 21 g
Spot 35	2 x 100 g
<b>Connections</b>	
Transmitter: Brown (1)	+24 VDC
White (2)	Dynamic signal in
Blue (3)	0 VDC
Receiver: Brown (1)	+24 VDC
White (2)	
Blue (3)	0 VDC
Black (4)	Dynamic signal out
Grey (5)	Info output
24 VDC when LED is green or flashing (tolerance -2 VDC) 0 VDC when LED is off (tolerance +2 VDC)	
<b>Conformity</b>	European Machinery Directive 2006/42/EC <b>CE</b> EN ISO 12100-1:2003 EN ISO 12100-2:2003 EN 60204-1:2006 + A1:2009 EN 954-1:1996, EN ISO 13849-1:2008 EN 62061:2005, EN 61496
<b>Certifications</b>	TÜV Nord

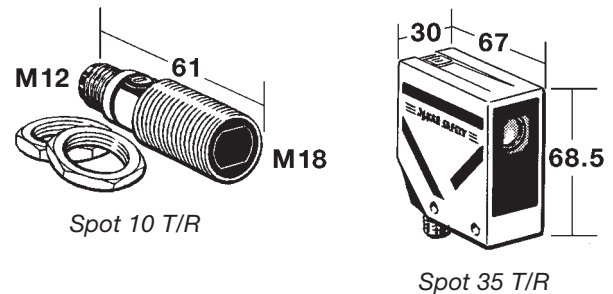

# Connection Examples

## Connection of Spot T/R to Vital 1

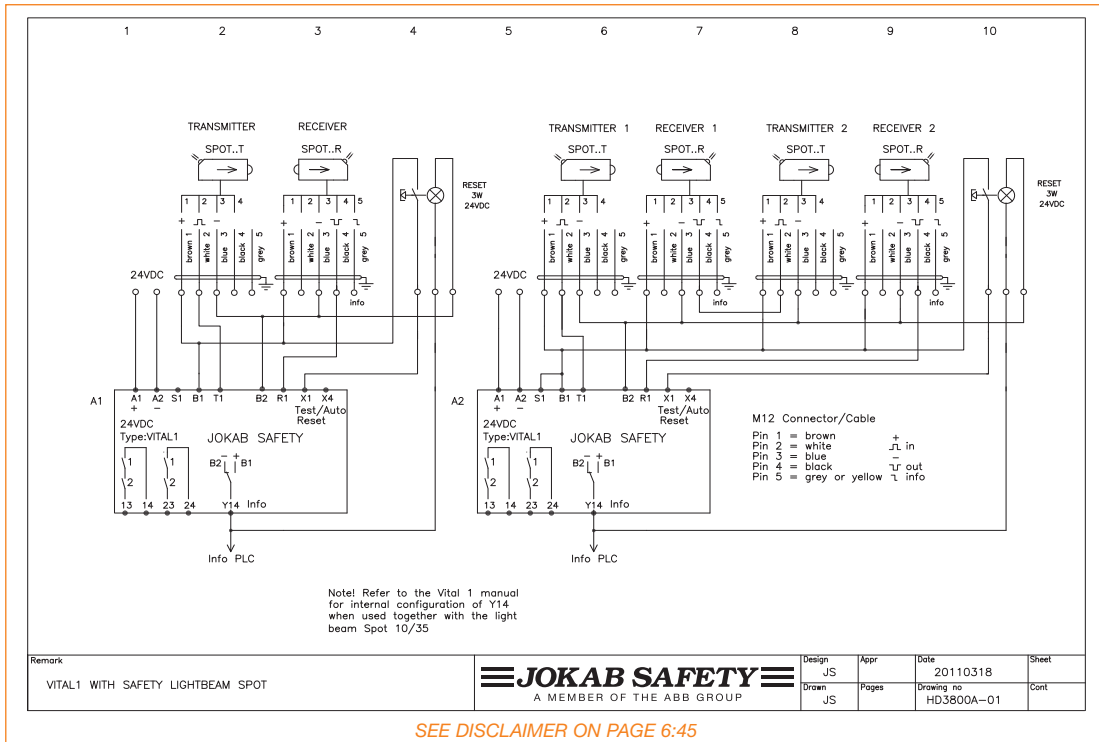

# Connection Example

## Vital 1 with 3 Lightbeams Spot

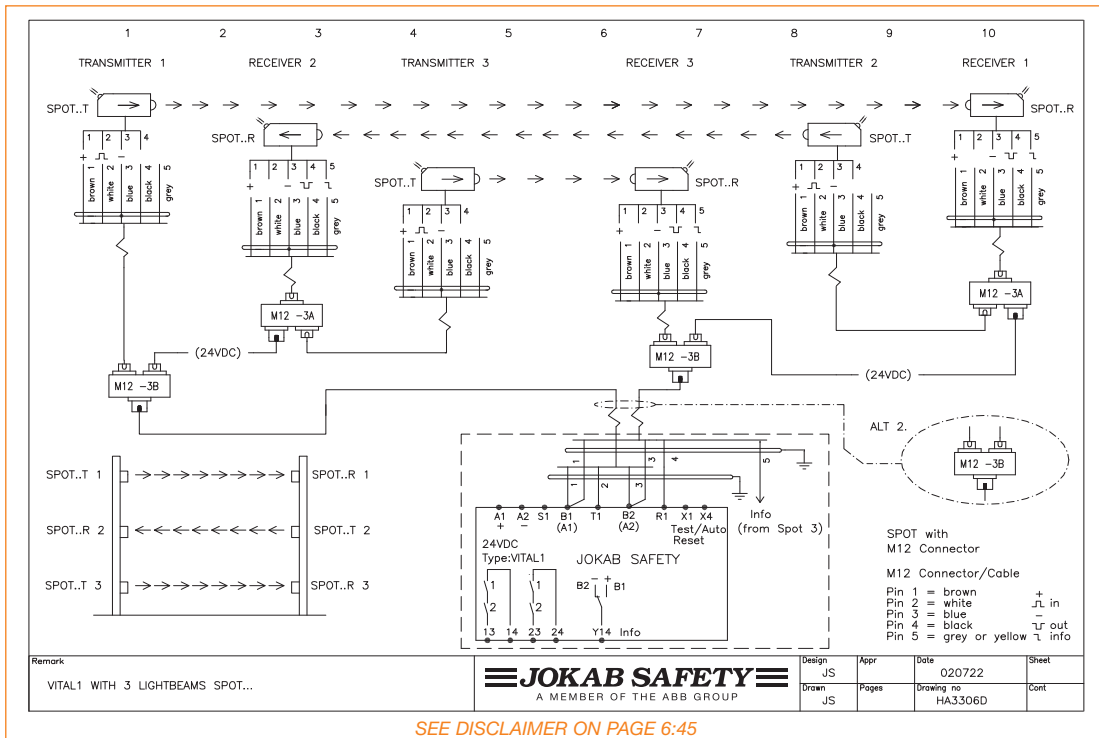

Note: For more connection examples see sections for Vital or Pluto

## Spot Resetting - 3 Possibilities

### Supervised Manual Reset (Figure 1)

When the Spot Light Beam is broken Vital gives stop signals to dangerous machines inside the guarded area and the reset indication lamp is on. A new start of the machine requires a reset of the Light Beam. The reset button must be placed so that it cannot be reached from inside the guarded area and so that it has to be activated from outside the machine. When the reset button has been activated, i.e. the reset inputs have been both closed and opened, the outputs from the Vital are activated, the reset indication lamp is off and the machine can be started. High demands are placed on the reset function, a fault must not lead to the ready signal being given when someone has interrupted the Light Beam. (See connection example HD3800A on page 4:46.)

### Supervised Time Resetting (Figure 2)

To reset the Light Beam, push button 1 must first be pressed and then push button 2 (within the predetermined preset time). This prevents unintentional resetting when someone is within the hazardous area. This is especially important when the area which is being protected by the Light Beam is not clearly visible from outside.

When time resetting is performed the safety timer relay JSHT1 A/B is used together with the Vital. This allows pre-reset times (in steps from 5 to 40 seconds) to be set. (See connection example HE3811B on page 4:46.)

### Automatic Reset (Figure 3)

Automatic reset is utilized for example when a light beam is used to monitor an area. In this case when the Light Beam is interrupted this indicates that the robot is operating in the area allowing it to be stopped if a person enters into the same area. When the Light Beam is clear, the Vital is reset automatically.

## Bypassing

### Automatic Bypassing (Figure 4)

For the transport of materials, the Light Beams, grids or curtains can be bypassed just before they are interrupted. The bypassing is achieved by sensors which detect the auto carrier and give signals direct or via a safety relay to the Vital.

In the connection examples you can find a number of different solutions. (See connection examples HE3824C-E on pages 4:47 and 4:48.)

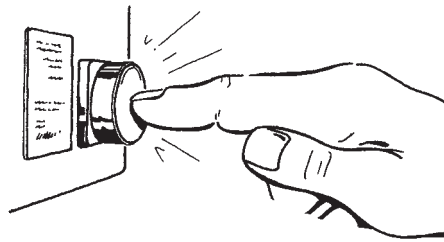

Figure 1 - Reset push button with lamp indication.

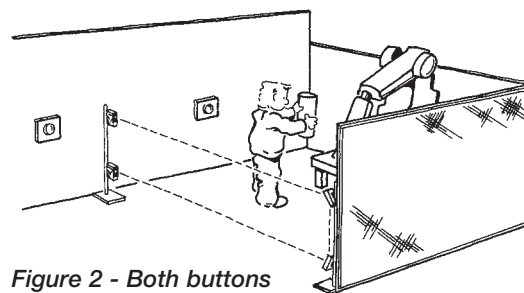

Figure 2 - Both buttons 1 and 2 need to be pressed (in sequence) within the pre-reset time to reset the Spot Light Beam

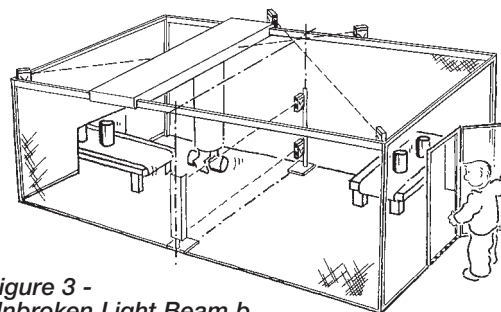

Figure 3 - Unbroken Light Beam b indicates that the industrial robot is outside area B. Area B can now be entered without stopping the robot.

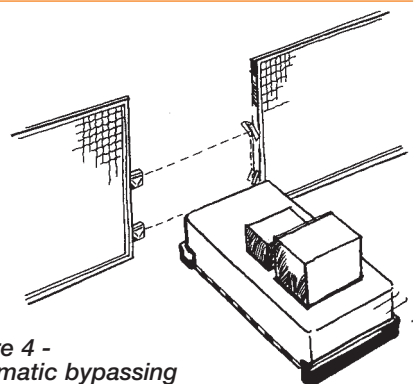

Figure 4 - Automatic bypassing when auto carrier passes.

# BP1 Blanking Programmer

## A Quick Way to Program Blanking

A dipswitch at the cable connection of the Light Curtain receiver enables a choice of whether a blanking function is to be used. Once this choice has been made, programming of the unit in the light field is made easy by using the Blanking Programmer BP1.

If the extent of the object in the protected field then changes, the Light Curtain can be reprogrammed—only 11 seconds after the push button on the front of the BP1 has been pressed.

The BP1 is easily connected, in series with the cable to the Light Curtain receiver unit, using the M12 connector and the free length of the unit's cable.

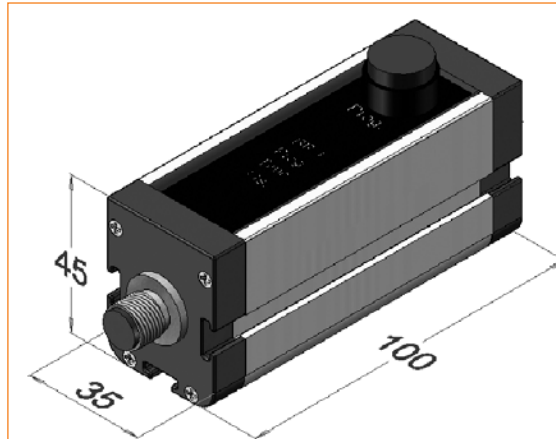

*The BPI must be removed before power is applied to the machine controls.*



### BP1 Technical Data

Manufacturer	ABB AB/Jokab Safety, Sweden
Ordering information	see page 6:42
Color	yellow and black

# Muting Sensor Mute R Retro/Reflective with Polarizing Filters

## Features

- Adjustable Range
- Light reserve warning indicator
- Transistor output, PNP
- 1000 Hz switching frequency
- Short-circuit protection, reverse polarity protection and power-up output suppression
- M12 connector
- EMC tested according to IEC 801 and EN 50081-1/En 50082-2



## Approvals



## Mute R Technical Data

Manufacturer	ABB AB/Jokab Safety, Sweden
Ordering information	see page 6:42
Weight	approx. 15 g
Output	PNP, dark on
Connection	M12 connector
Range Adjustment	Yes
Range	0.15 - 2.5 m (with reflector FZR1) 0.15 - 5 m (with reflector FZR2)
Light Source	Visible-red, 660 nm, pulsed with polarizing filter
Supply Voltage	10 - 30 VDC
Allowable Ripple	+/- 10% of $U_S$
Current Consumption without Load	<15 mA
Maximum Load Current	100 mA
Residual Voltage	<1.6V
Maximum Switching Frequency	1000 Hz
Temperature (Operating and Storage)	-25°C to +65°C
Protection Class	IP67

*Note: All technical data at 25°C and 24V*

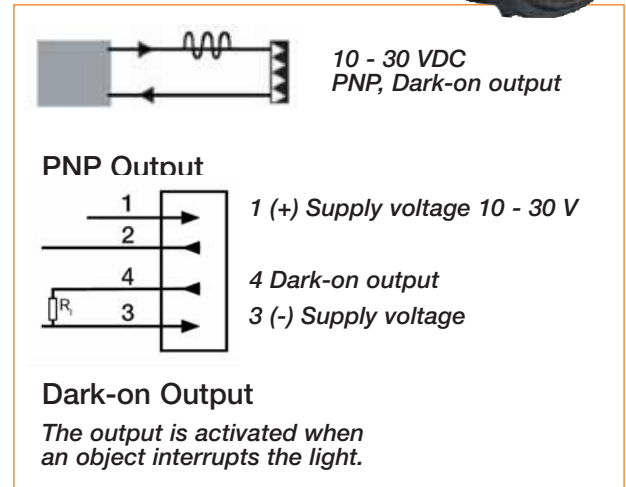

M12 Connector

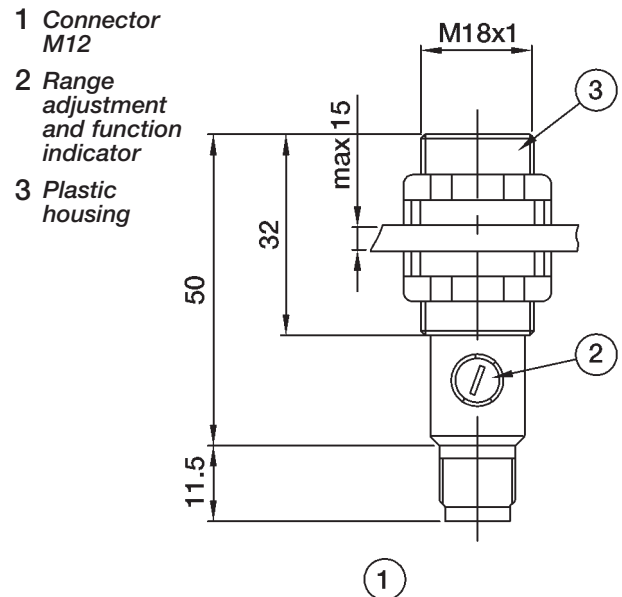
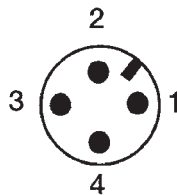

# Muting Sensor Mute D Diffuse with Background Rejection

## Features

- Electronically adjustable background rejection
- Light reserve warning indicator
- Dual transistor outputs, PNP
- Short-circuit protection, reverse polarity protection and power-up output suppression
- Rotatable M12 connector
- EMC tested according to IEC 801 and EN 50081-1/EN 50082-2

## Approvals



## Mute D Technical Data

Manufacturer	ABB AB/Jokab Safety, Sweden
Ordering information	see page 6:42
Weight	approx. 130 g
Output	2 PNP (light-on and dark-on)
Connection	M12 connector
Range Adjustment	Yes
Range	0.2 - 0.8 m
Light Source	Infrared-LED, 880 nm, pulsed
Supply Voltage	10 - 30 VDC
Allowable Ripple	+/- 10% of $U_S$
Current Consumption without Load	<35 mA
Maximum Load Current	200 mA
Residual Voltage	<1.6V
Maximum Switching Frequency	200 Hz
Temperature (Operating and Storage)	-25°C to +65°C
Protection Class	IP67

*Note: All technical data at 25°C and 24V*

## M12 Connector

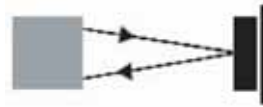
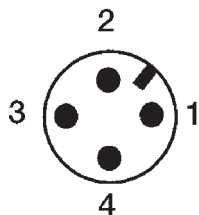

10 - 30 VDC  
PNP, Light-on output  
Dark-on output

### PNP Output

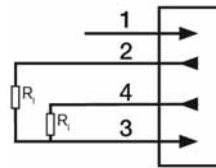

1 (+) Supply voltage 10 - 30 V  
2 Dark-on output  
4 Light-on output  
3 (-) Supply voltage

### Light-on Output

Output energized when object is present.

### Dark-on Output

Output energized when no object is present.

- 1 Function indicator
- 2 Range adjustment
- 3 Glass-covered optics
- 4 Center of the optical axis

- 5 Preferred detection direction
- 6 Bore for 5mm self-tapping screw
- 7 M12 Connector
- 8 Opening for M5 nut

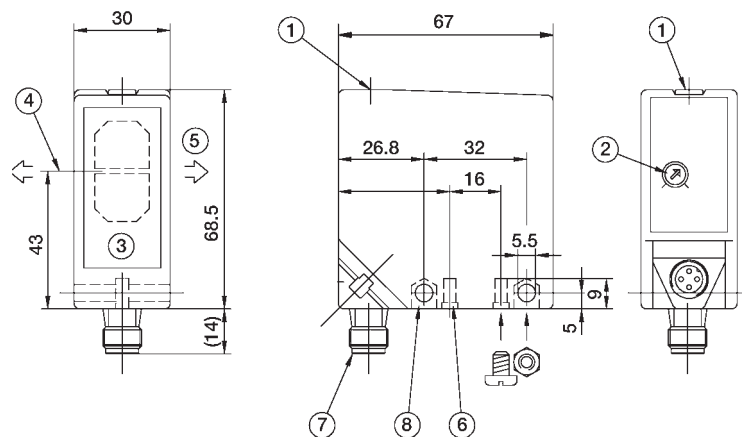

# JSRL-3/JSRL-4 Laser Aligner

When the solution involves one or more mirrors, JSRL-3/4 facilitates alignment of Light Beams or Light Curtains. The JSRL-3/4 is easily secured using the accompanying elasticated tape around the transmitter and receiver unit, and must be placed so that the flat rear of the unit is up against the front glass of the Light Curtain. When the laser aligner is switched on, the red laserspot should be visible at the corresponding unit, even via mirrors.

The JSRL-3/4 contains two type AAA batteries that are changed by unscrewing the bottom end cap.

## Application

- Alignment of light curtains/beams

## Features

- Facilitates alignment

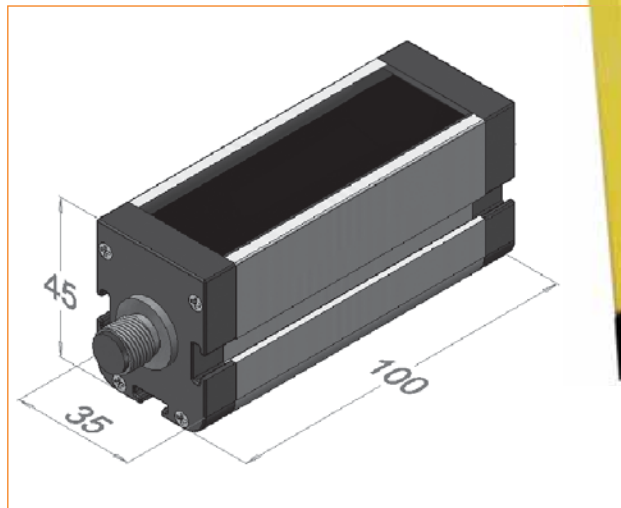

## JSRL-3/JSRL-4 Technical Data

Manufacturer	ABB AB/Jokab Safety, Sweden
Ordering information	see page 6:41
Color	Yellow and black



# Connection Examples Contents

Connection of Spot T/R to Vital 1.....	6:25
Vital 1 with 3 Lightbeams Spot.....	6:25
<b>HR7000C-01</b>	
Focus - Connection without and with Muting Function.....	6:32
<b>HR7000E-01</b>	
Focus - Connection with Pre-Reset Function.....	6:32
<b>HR7000F-01</b>	
Focus - Connection with Muting to Safety Relay.....	6:33
<b>HR7000G-01</b>	
Focus - Connection with MFII-T/MFII-L Units.....	6:33
<b>HR7000H-01</b>	
Focus - Connection with FMC/Tina Interface.....	6:34
<b>HR7000I-01</b>	
FMC.....	6:34
<b>HR7000J-01</b>	
FMC-1 or FMC-1 Tina with Muting Sensors and Reset Unit.....	6:35
<b>HR7000K-01</b>	
FMC-1 or FMC-1 Tina Connected with Pre Reset.....	6:35
<b>HR7000L-01</b>	
Tina 10A, 10B and 10C Connection .....	6:36
<b>HR7000M</b>	
FRM-1 Changing OSSD Outputs to Relay Contacts .....	6:36
<b>HR7000O-01</b>	
FMC/FMI Connection .....	6:37
<b>HR7000P</b>	
Cable Connection .....	6:37
<b>HR7000Q</b>	
Cable Connection .....	6:38
<b>HR7000S</b>	
Focus; Muting with the Aid of Pluto, FMC and a Transfer Cable .....	6:38

## Connection Example

### HR7000C-01 Focus - Connection without and with Muting Function

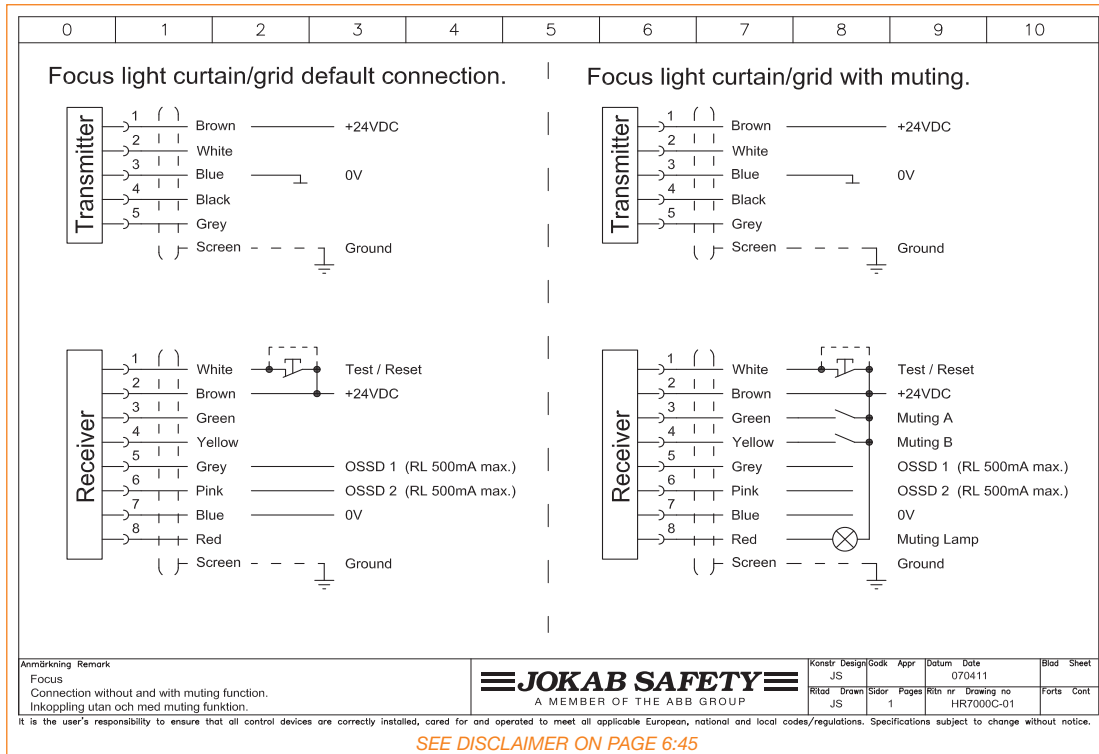

## Connection Example

### HR7000E-01 Focus - Connection with Pre-Reset Function

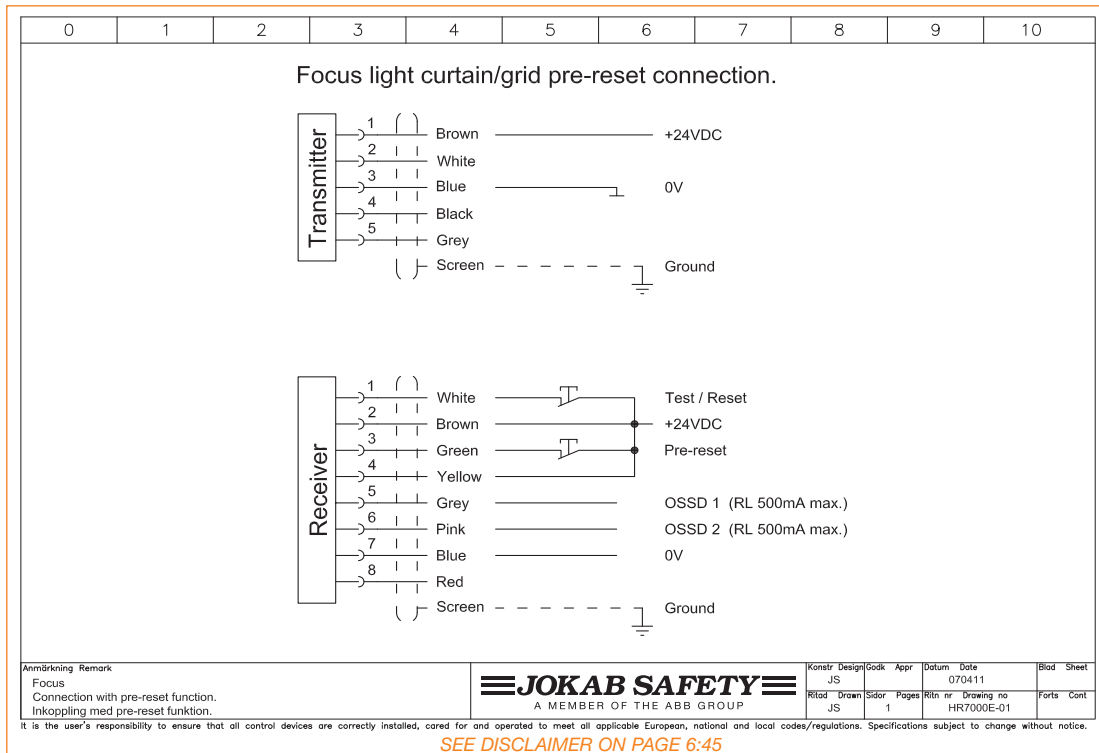

# Connection Example

## HR7000F-01 Focus - Connection with Muting to Safety Relay

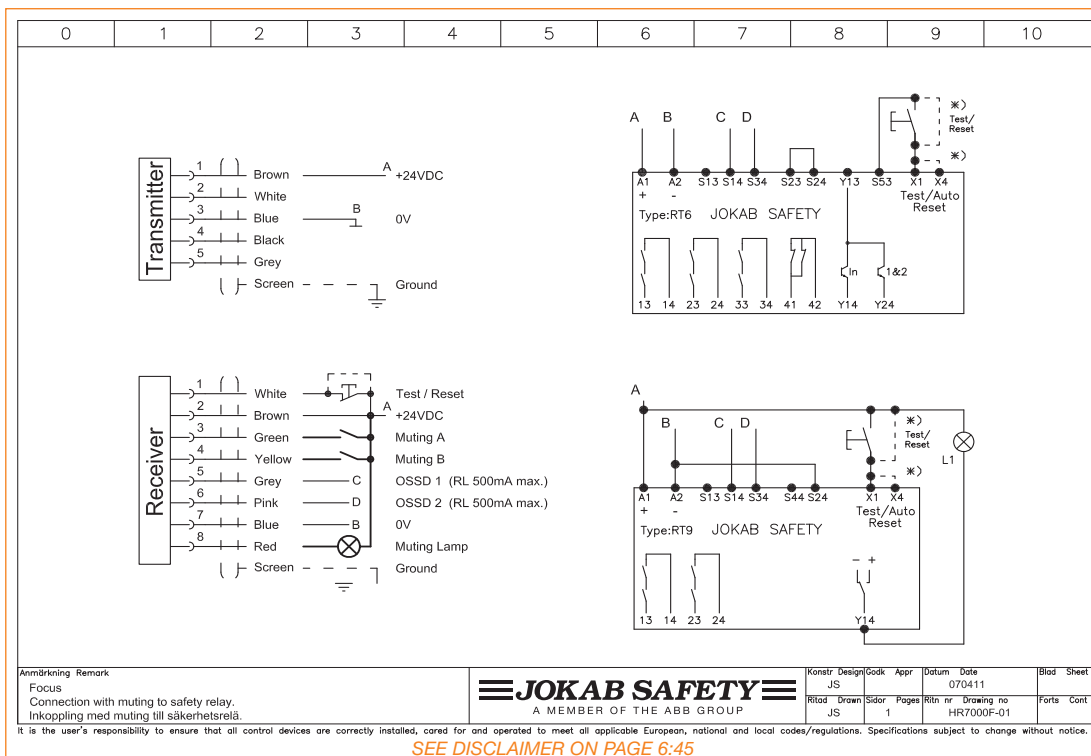

# Connection Example

## HR7000G-01 Focus - Connection with MFII-T/MFII-L Units

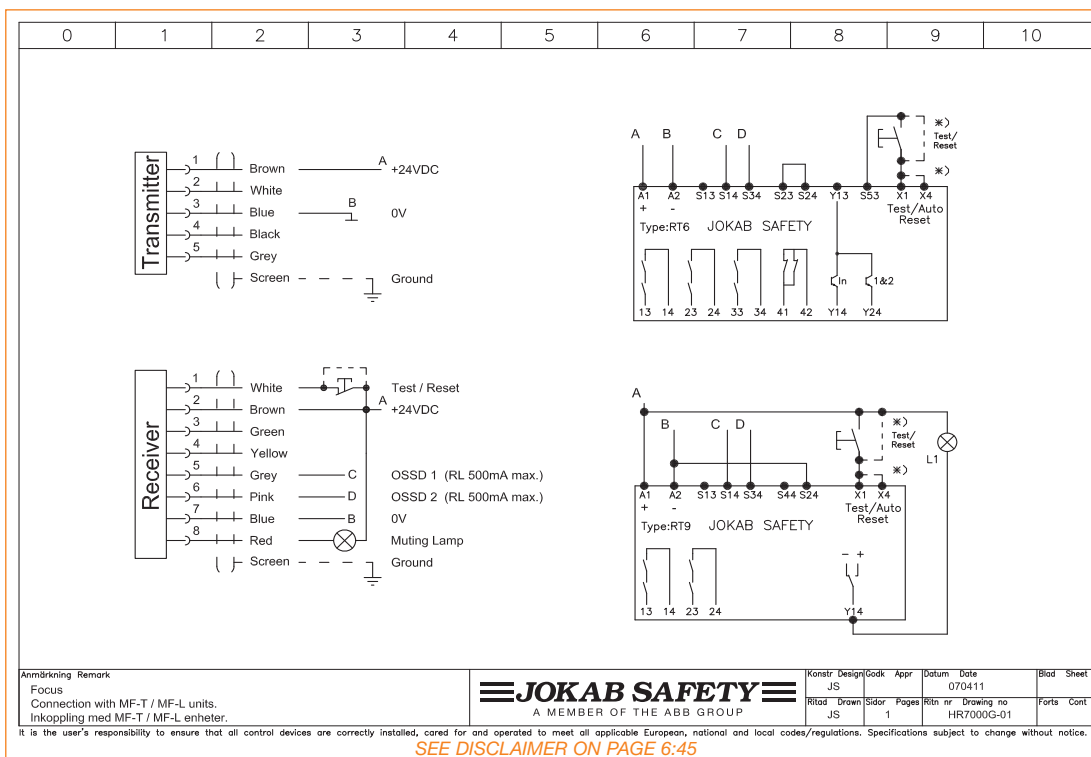

# Connection Example

## HR7000H-01 Focus - Connection with FMC/Tina Interface

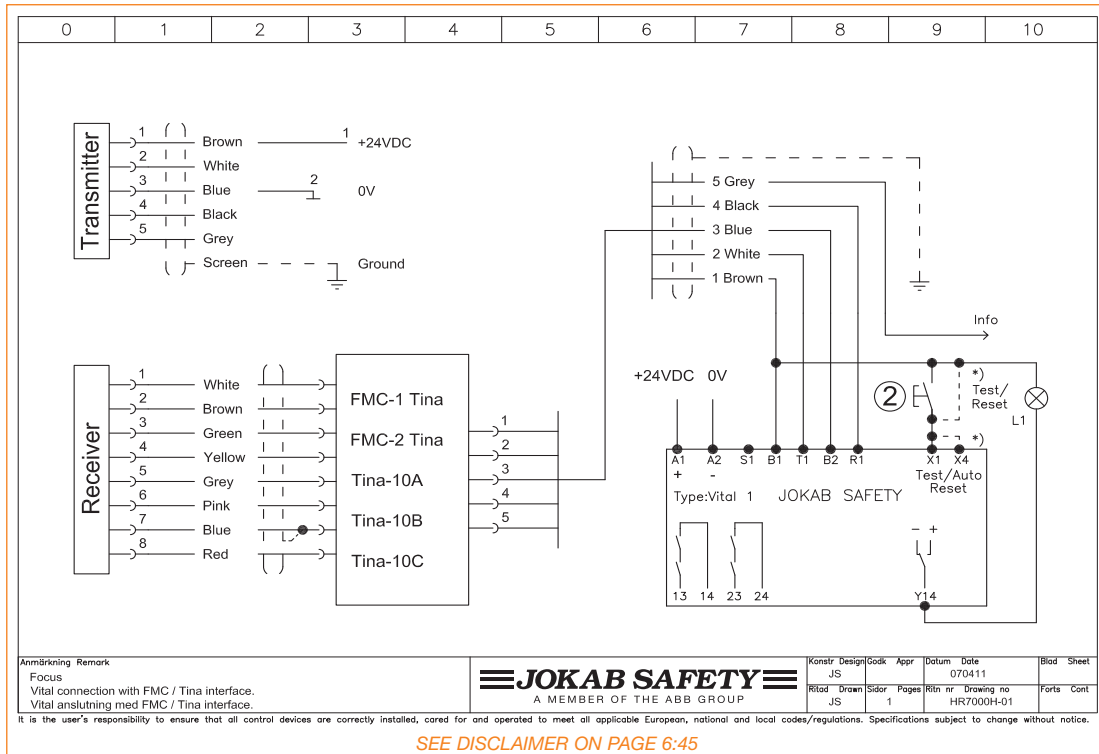

# Connection Example

## HR7000I-01 FMC

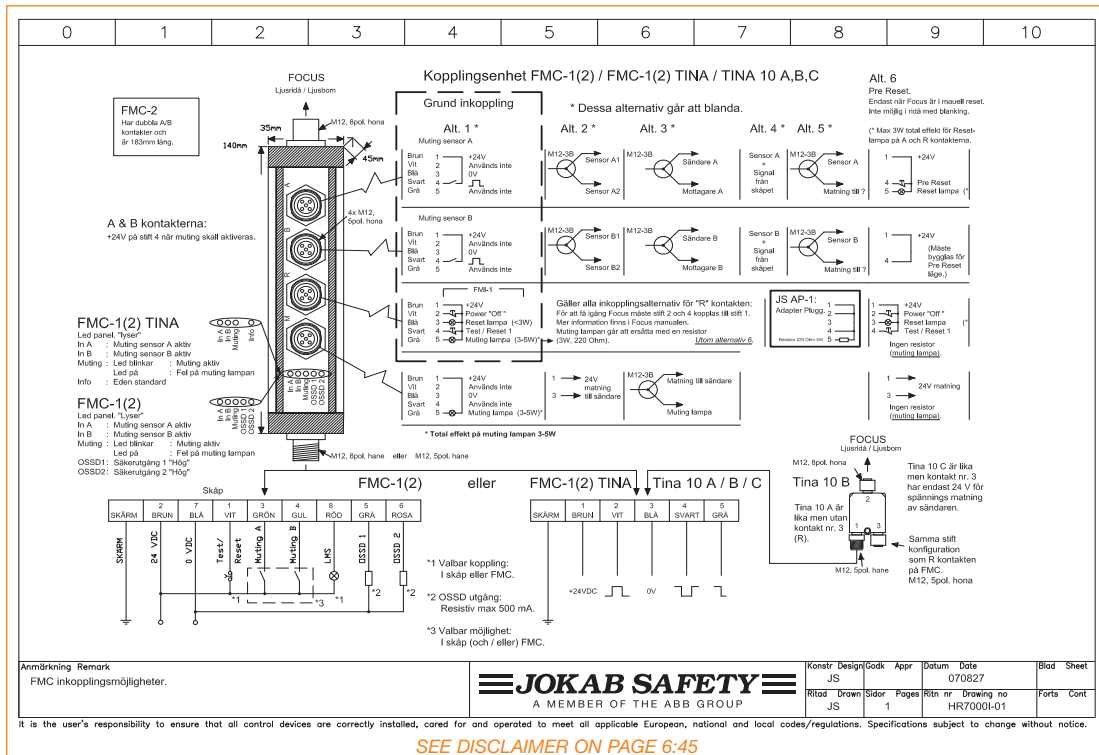

# Connection Example

## HR7000J-01 FMC-1 or FMC-1 Tina with Muting Sensors and Reset Unit

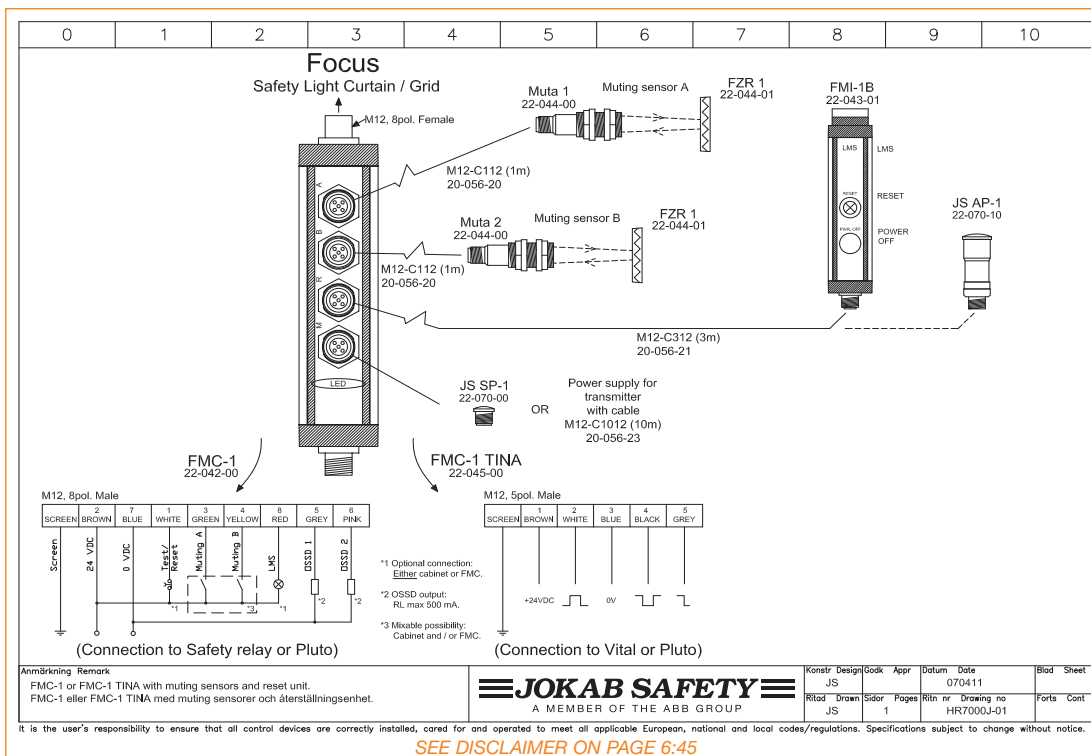

# Connection Example

## HR7000K-01 FMC-1 or FMC-1 Tina Connected with Pre Reset

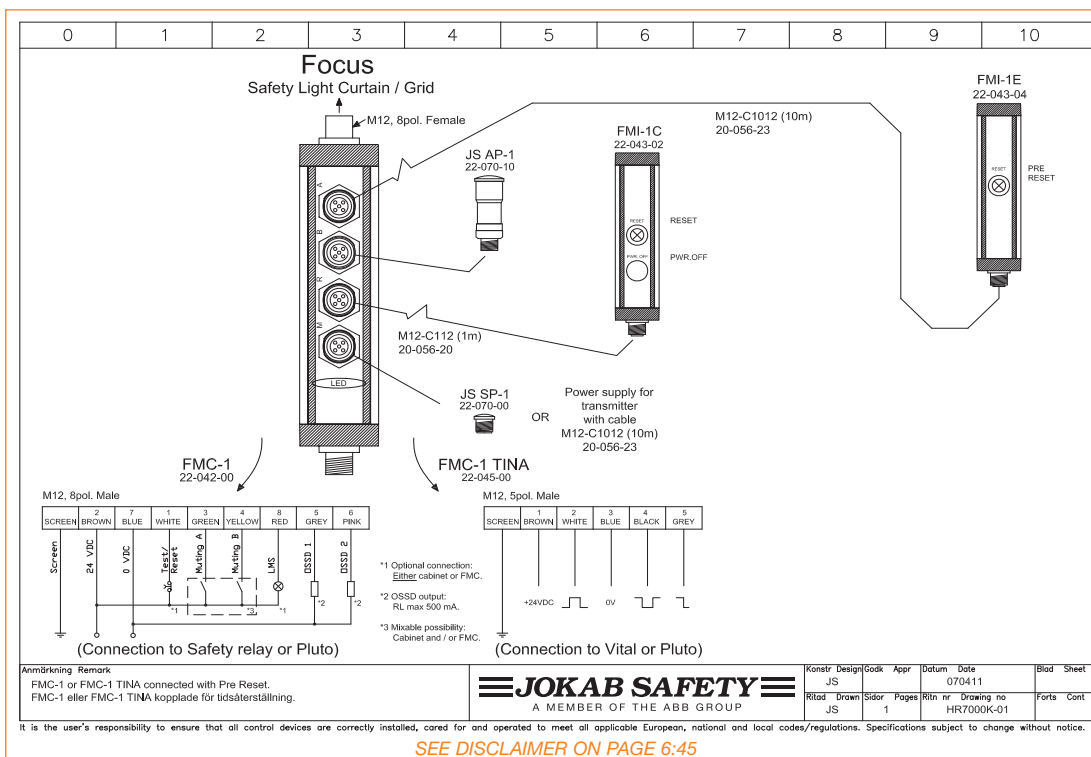

# Connection Example

## HR7000L-01 Tina 10A, 10B and 10C Connection

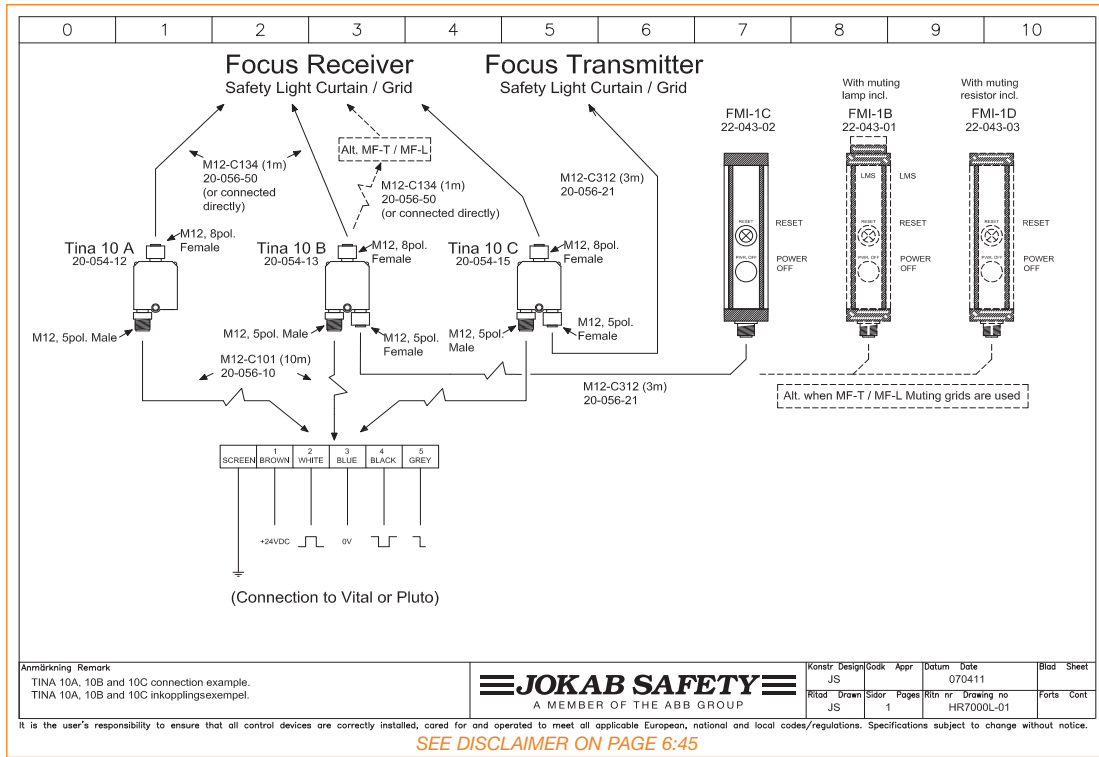

# Connection Example

## HR7000M FRM-1 Changing OSSD Outputs to Relay Contacts

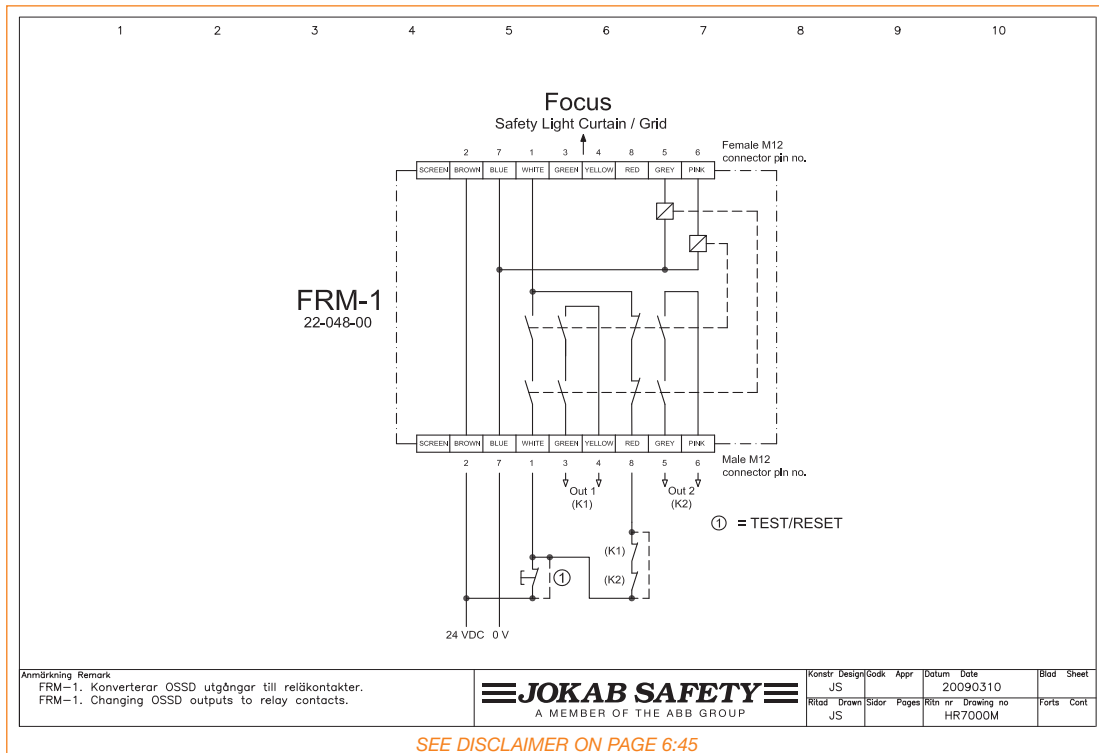

# Connection Example

## HR7000-01 FMC/FMI Connection

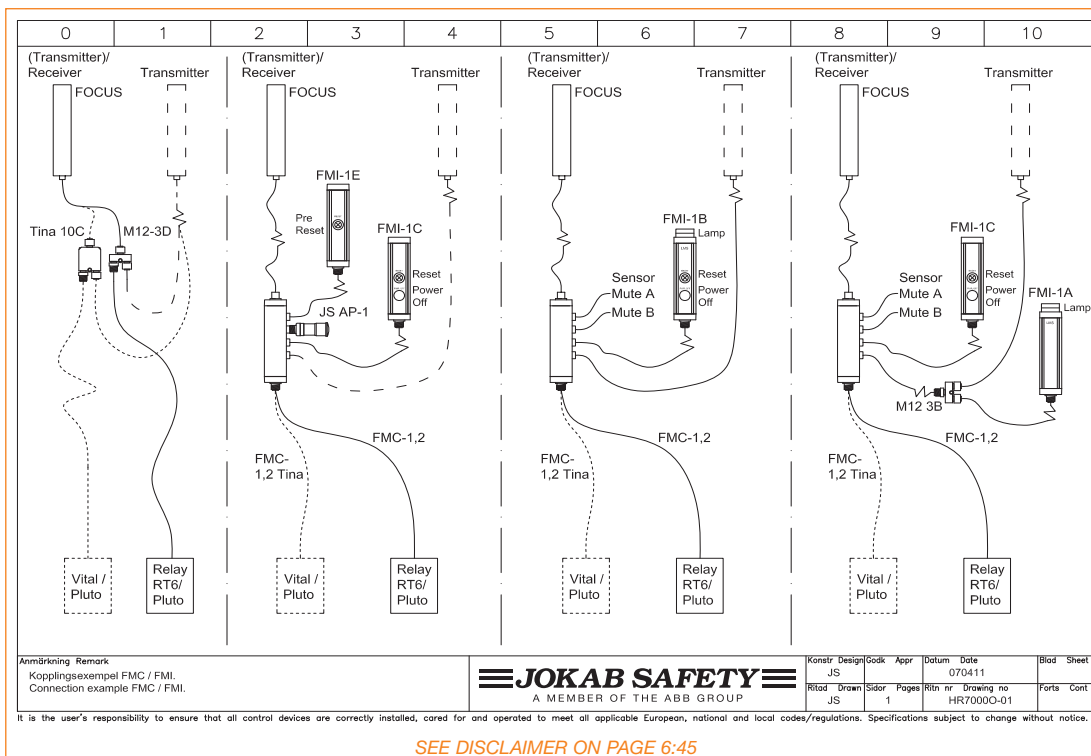

# Connection Example

## HR7000P Cable Connection

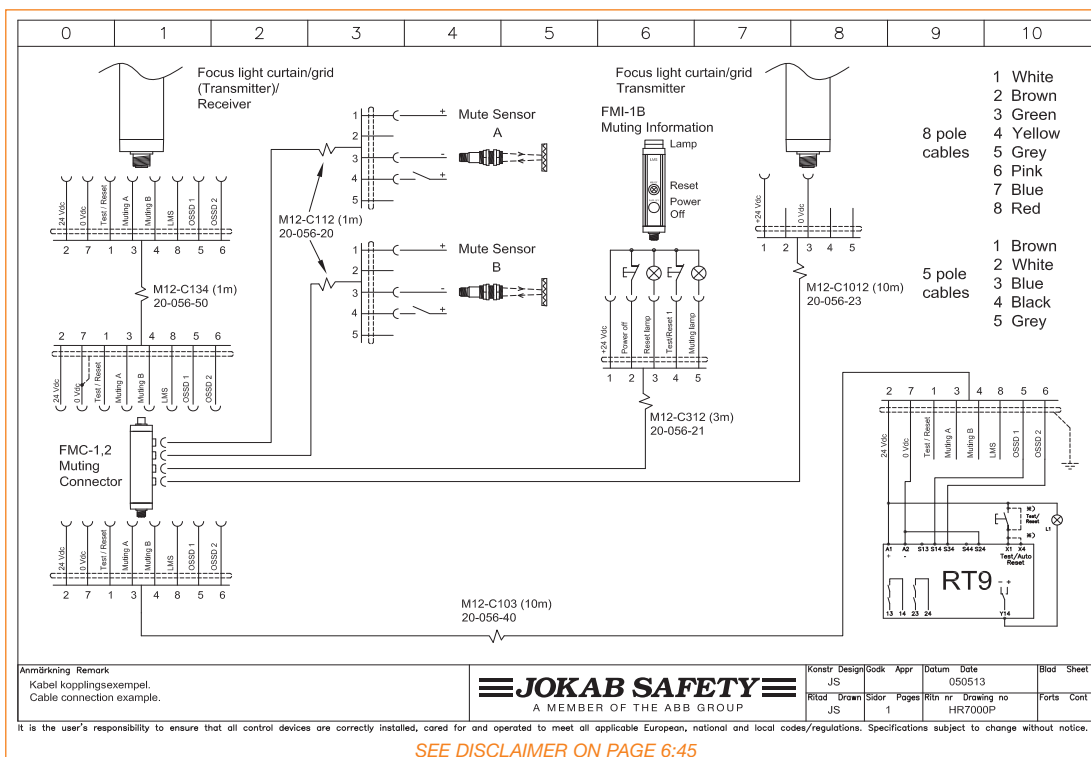

# Connection Example

## HR7000Q Cable Connection

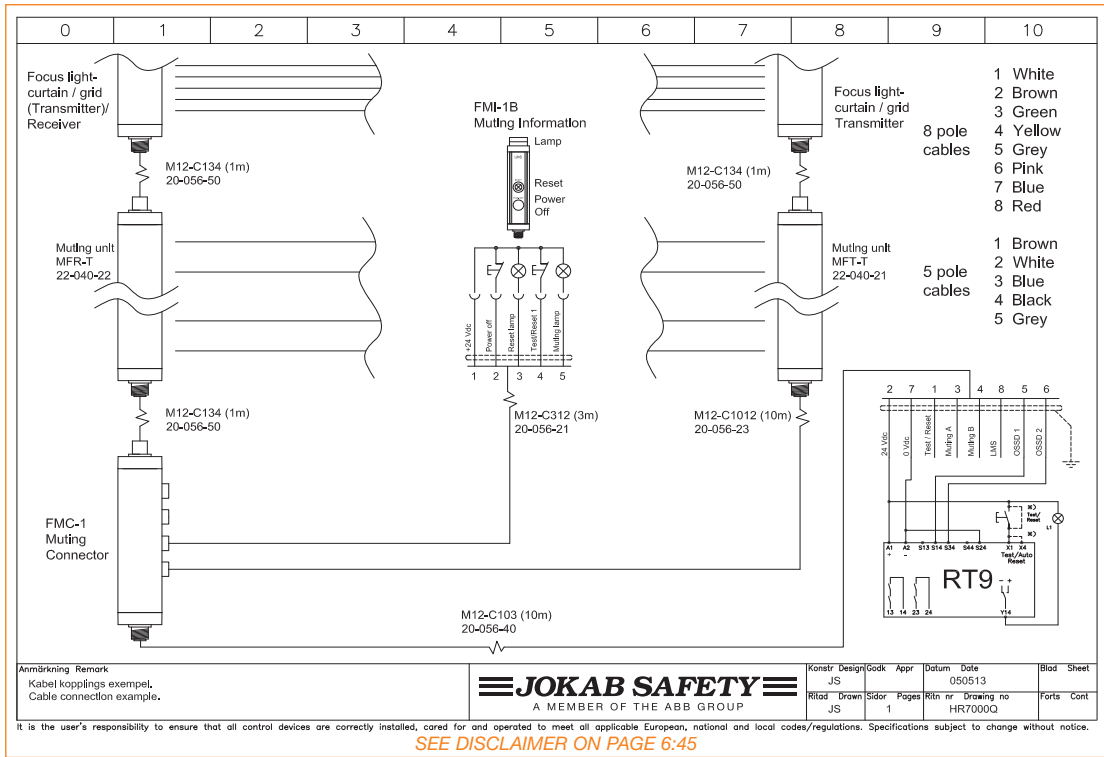

# Connection Example

## HR7000S Focus; Muting with the Aid of Pluto, FMC and a Transfer Cable

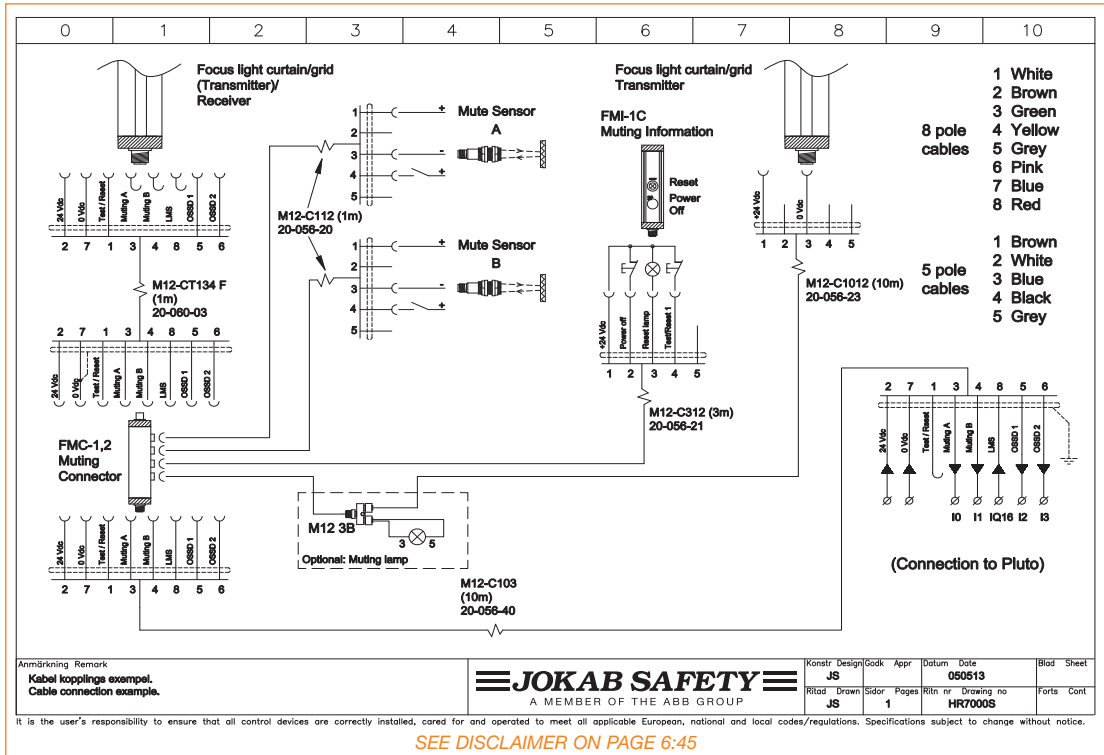



## Component List - Mirrors

Designation	Ordering Information	Description
MF-150	2TLA850110R0800	Focus Light Curtain Mirror Kit, includes mirrors and mounting brackets. For use with 150mm Focus Safety Light Curtains.
MF-300	2TLA850110R0900	Focus Light Curtain Mirror Kit, includes mirrors and mounting brackets. For use with 300mm Focus Safety Light Curtains.
MF-450	2TLA850110R1000	Focus Light Curtain Mirror Kit, includes mirrors and mounting brackets. For use with 450mm Focus Safety Light Curtains..
MF-600	2TLA850110R1100	Focus Light Curtain Mirror Kit, includes mirrors and mounting brackets. For use with 600mm Focus Safety Light Curtains.
MF-750	2TLA850110R1200	Focus Light Curtain Mirror Kit, includes mirrors and mounting brackets. For use with 750mm Focus Safety Light Curtains.
MF-800	2TLA850110R1300	Focus Light Curtain Mirror Kit, includes mirrors and mounting brackets. For use with 800mm Focus Safety Light Curtains.
MF-900	2TLA850110R1400	Focus Light Curtain Mirror Kit, includes mirrors and mounting brackets. For use with 900mm Focus Safety Light Curtains.
MF-1050	2TLJ022041R1500	Focus Light Curtain Mirror Kit, includes mirrors and mounting brackets. For use with 1050mm Focus Safety Light Curtains.
MF-1200	2TLA850110R1600	Focus Light Curtain Mirror Kit, includes mirrors and mounting brackets. For use with 1200mm Focus Safety Light Curtains.
MF-1350	2TLA850110R1700	Focus Light Curtain Mirror Kit, includes mirrors and mounting brackets. For use with 1350mm Focus Safety Light Curtains.
MF-1500	2TLA850110R1800	Focus Light Curtain Mirror Kit, includes mirrors and mounting brackets. For use with 1500mm Focus Safety Light Curtains.
MF-1650	2TLA850110R1900	Focus Light Curtain Mirror Kit, includes mirrors and mounting brackets. For use with 1650mm Focus Safety Light Curtains.
MF-1800	2TLA850110R2000	Focus Light Curtain Mirror Kit, includes mirrors and mounting brackets. For use with 1800mm Focus Safety Light Curtains.
JSNA-FOCUS-MC	2TLA850010R0900	2000mm Quick-Guard Stand 44mm x 88mm Light Curtain/Mirror mounting post with endcaps and 2 floor mounts.
	2TLJ022041R2000	Brackets for MF mirrors for mounting to Quick-Guard extruded aluminum. 2 required for each mirror.

## Component List - Bjorn Support for Light Grids and Mirrors

Designation	Ordering Information	Description
Bjorn UC-3	2TLA850210R6100	Protective floor mounted housing for 1 vertically mounted Focus Light Curtain or Grid up to 1200mm in length.
Bjorn UC-4	2TLA850310R1700	Protective floor mounted housing for 1 vertically mounted Focus Light Curtain or Grid up to 1800mm in length.
Bjorn UC-8	2TLA850210R8300	Left hand protective floor mounted housing for 1 horizontally mounted Focus Light Curtain or Grid up to 1200mm in length.
Bjorn UC-9	2TLA850210R8700	Right hand protective floor mounted housing for 1 horizontally mounted Focus Light Curtain or Grid up to 1200mm in length.
Bjorn UC-10	2TLA850120R5500	Protective floor mounted housing for 2 vertically mounted Focus Light Curtains or Grids at 90 degrees up to 1200mm in length.

## Component Wet Wash Down Tubes

Designation	Ordering Information	Description
WET-150 FII	2TLJ022038R4000	Wash down tube kit for use with 150mm Focus II Safety Light Curtains.
WET-300 FII	2TLJ022038R4100	Wash down tube kit for use with 300mm Focus II Safety Light Curtains.
WET-450 FII	2TLJ022038R4200	Wash down tube kit for use with 450mm Focus II Safety Light Curtains.
WET-600 FII	2TLJ022038R4300	Wash down tube kit for use with 600mm Focus II Safety Light Curtains.
WET-750 FII	2TLJ022038R4400	Wash down tube kit for use with 750mm Focus II Safety Light Curtains.
WET-900 FII	2TLJ022038R4500	Wash down tube kit for use with 900mm Focus II Safety Light Curtains.
WET-1050 FII	2TLJ022038R4600	Wash down tube kit for use with 1050mm Focus II Safety Light Curtains.
WET-1200 FII	2TLJ022038R4700	Wash down tube kit for use with 1200mm Focus II Safety Light Curtains.
WET-1350 FII	2TLJ022038R4800	Wash down tube kit for use with 1350mm Focus II Safety Light Curtains.
WET-1500 FII	2TLJ022038R4900	Wash down tube kit for use with 1500mm Focus II Safety Light Curtains.
WET-1650 FII	2TLJ022038R5000	Wash down tube kit for use with 1650mm Focus II Safety Light Curtains.
WET-1800 FII	2TLJ022038R5100	Wash down tube kit for use with 1650mm Focus II Safety Light Curtains.
WET-K500 FII	2TLJ022038R5200	Wash down tube kit for use with 500mm Focus II Safety Light Grids.
WET-K800 FII	2TLJ022038R5300	Wash down tube kit for use with 800mm Focus II Safety Light Grids.
WET-K900 FII	2TLJ022038R5400	Wash down tube kit for use with 900mm Focus II Safety Light Grids.
WET-K1200 FII	2TLJ022038R5500	Wash down tube kit for use with 1200mm Focus II Safety Light Grids.
WET-MF-T FII	2TLJ022038R5700	Wash down tube kit for use with 500mm Focus II Safety Light Transceivers.
WET-MF-L FII	2TLJ022038R5600	Wash down tube kit for use with 500mm Focus II Safety Light Transceivers.

## Component List - Spot Light Beams

Designation	Ordering Information	Description
Spot 10T/R	2TLJ020009R0600	Safety light beam with 10m range, 24VDC supply, multi-function status indicator LEDs, integrated information output 24VDC - 10mA on receiver, IP67 protection class, M18 barrel style steel housing, 5 pole M12 male quick disconnect. Requires Vital 1 controller/Pluto to function. Provides safety category level 4 according to EN954-1 with Vital 1 controller/Pluto. Maximum of 6 light beam pairs connected to one controller possible while maintaining category 4 level of safety.
Spot 35T/R	2TLJ020009R0500	Safety light beam with 35m range, 24VDC supply, multi-function status indicator LEDs, integrated information output 24VDC - 10mA on receiver, IP67 protection class, plastic housing, 5 pole M12 male quick disconnect. Requires Vital 1 controller/Pluto to function. Provides safety category level 4 according to EN954-1 with Vital 1 controller/Pluto. Maximum of 6 light beam pairs connected to one controller possible while maintaining category 4 level of safety. 2 pieces of JSM 63 brackets are included.
JSRL2	2TLJ020008R0100	Laser alignment aid for SPOT 35 single beams. Secured by an adjustable elastic fabric band around the sensing unit. Housed in the SPOT housing with 4 pole M12 connector for power connection via existing SPOT cable.

## Component List - Focus Quick Connections

Designation	Ordering Information	Description
TINA 10A	2TLJ020054R1200	Tina dynamic adapter with 5 pole M12 male quick disconnect for connecting transistor output safety devices to the Vital 1 controller. 8 pole M12 female quick disconnect for direct connection to the safety device or safety device enclosure, 24VDC supply, multi-function status indicator LEDs, integrated information output 24VDC - 10mA.
TINA 10B	2TLJ020054R1300	Tina dynamic adapter with 5 pole M12 male quick disconnect for connecting transistor output safety devices to the Vital 1 controller. 8 pole M12 female quick disconnect for direct connection to the safety device or safety device enclosure. Additional 5 pole M12 connector for local reset capabilities, 24VDC supply, multi-function status indicator LEDs, integrated information output 24VDC - 10mA.
TINA 10C	2TLJ020054R1600	Tina dynamic adapter with 5 pole M12 male quick disconnect for connecting transistor output safety devices to the Vital 1 controller. 8 pole M12 female quick disconnect for direct connection to the safety device or safety device enclosure. Additional 5 pole M12 connector for connection of light curtain transmitter, 24VDC supply, multi-function status indicator LEDs, integrated information output 24VDC - 10mA.
FMC-1	2TLA022042R0000	Focus Muting Connector, connects from the Focus receiver. 4 M12, 5 pin female connections for 2 muting sensors, muting lamp and reset push button. M12, 8 pin male connector for machine interface.
FMC-1 Tina	2TLA022045R0000	Focus Muting Connector, connects from the Focus receiver. 4 M12, 5 pin female connections for 2 muting sensors, muting lamp and reset push button. Integrated Vital Tina M12, 5 pin male connector for machine interface.
FMC-2	2TLA022042R1000	Focus Muting Connector, connects from the Focus receiver. 6 M12, 5 pin female connections for 4 muting sensors, muting lamp and reset push button. M12, 8 pin male connector for machine interface.
FMC-2 Tina	2TLA022046R0000	Focus Muting Connector, connects from the Focus receiver. 6 M12, 5 pin female connections for 4 muting sensors, muting lamp and reset push button. Integrated Vital Tina M12, 5 pin male connector for machine interface.
FMI-1A	2TLA022043R0000	Focus Muting Lamp, 24VDC, 5W integrated muting lamp in a protective Focus housing.
FMI-1B	2TLA022043R0100	Focus Muting Connector, integrated 24VDC, 5W muting lamp, reset push button and power interrupt in a protective Focus housing.
FMI-1C	2TLA022043R0200	Focus Muting Connector, integrated reset push button and power interrupt in a protective Focus housing.
FMI-1D	2TLA022043R0300	Focus Muting Connector, integrated reset push button and power interrupt in a protective Focus housing. Muting resistor included.
FMI-1E	2TLA022043R0400	Focus Muting Connector, integrated reset push button for pre-reset or Tina Duo 2 in a protective Focus housing.
FMI-1G	2TLA022043R0500	Focus Muting Initiator, Integrated reset push button in a protective Focus housing. Internal resistor for muting lamp.
JSSP-1	2TLA022070R0000	FMC empty port cover.
JSAP-1	2TLA022070R1000	FMC "R" port terminator with terminal jumpers and integrated muting resistor.
FRM-1A	2TLA022048R0000	Focus convertor from 2 transistor outputs to relay outputs in a protective Focus housing. M12, 8 pole male/female connectors for integration between Focus and the control circuit.

## Component List - Focus Quick Connections (continued)

Designation	Ordering Information	Description
M12-3A	2TLA020055R0000	M12 Y Connector for series connection. 2 M12 5 pole female connectors and 1 M12 5 pole male connector.
M12-3B	2TLA020055R0100	M12 Y Connector for parallel connection. 2 M12 5 pole female connectors and 1 M12 5 pole male connector.
M12-3D	2TLA020055R0300	M12 Y Connector, parallel Connection. 1 M12 8 pole female connector for connection of the Focus Receiver, 1 M12 5 Pole female connector for connection of the Focus Transmitter and 1 M12 8 pole male connector for panel connection.
BP1	2TLJ022090R2300	Focus FB version external teach box for inline connection to the Focus receiver for single push button teaching of fixed/floating blanking.

## Component List - Muting Sensors and Indicators

Designation	Ordering Information	Description
FSTR1 - Mute R	2TLA022044R0000	Retro-reflective muting sensor with polarized filter. 24VDC 18mm barrel style with range adjustments from 0.15 to 5m, light reserve warning indicator, 1000Hz switching frequency and M12 4 pole male connector.
FZR 1	2TLA022044R0100	Polarized 80mm circular reflector for use with the FSTR1 muting sensors. Offers a range of 0.15 to 2.5m. 5mm center mount through hole for mounting capabilities.
FZR 2	2TLA022044R0400	Polarized 100mm x 100mm reflector for use with the FSTR1 muting sensors. Offers a range of 0.15 to 5m.
Muting Sensor Mute D	2TLJ022044R1000	Muting sensor, diffuse-reflective with back ground suppression. 24VDC, 2 pnp light, dark switching, M12 4 pin connector in a IP67 housing.
JSM63	2TLA040007R0100	Bracket for cubic style single beam. Fixed 90 degrees.
JSM64	2TLA040007R0200	Adjustable mounting bracket with rotational knuckle for 18mm barrel style sensors.
MF-T	2TLA022040R2000	Focus Muting Actuator 669mm overall length with 4 preadjusted and integrated muting sensors. Applicable for entry and exit of material through the Focus Light Curtain or Grid.
MFT-T	2TLA022040R2100	Focus transmitter bar with 669mm overall length with 4 preadjusted and integrated muting transmitting sensors. Applicable for entry and exit of material through the Focus Light Curtain or Grid. Must be used with the MFR-T receiving bar.
MFR-T	2TLA022040R2200	Focus receiver bar with 669mm overall length with 4 preadjusted and integrated muting receiver sensors. Applicable for entry and exit of material through the Focus Light Curtain or Grid. Must be used with the MFT-T transmitting bar.
MF-L	2TLA022040R3000	362mm overall length with 2 preadjusted and integrated muting sensors. Applicable for exit of material through the Focus Light Curtain or Grid.
MF-T Reflex	2TLA022040R4000	Focus Muting Actuator with 4 preadjusted and integrated, retro-reflective muting sensors and retro-reflective passive target. Applicable for entry and exit of material through the Focus Light Curtain or Grid with wiring only to one side.

## Component List - Muting Sensors and Indicators (continued)

Designation	Ordering Information	Description
MFTR-T Reflex	2TLA022040R4100	Focus Muting Actuator with 4 preadjusted and integrated, retro-reflective muting sensors. Applicable for entry and exit of material through the Focus Light Curtain or Grid with wiring only to one side. Requires the M-T REFLEX passive target to operate.
M-T Reflex	2TLA022040R4200	Focus Muting Actuator, retro-reflective passive target. Applicable for entry and exit of material through the Focus Light Curtain or Grid with wiring only to one side. Requires the MFTR-T-REFLEX active sensor bar to operate.

## Component List - Transmitter Cables

Designation	Ordering Information	Description
M12-C61	2TLA020056R0000	Cable single ended 6 meters black PVC jacket with straight 5 pole M12 female molded connector, 22AWG conductors, overall braid shield.
M12-C101	2TLA020056R1000	Cable single ended 10 meters black PVC jacket with straight 5 pole M12 female molded connector, 22AWG conductors, overall braid shield.
M12-C201	2TLA020056R1400	Cable single ended 20 meters black PVC jacket with straight 5 pole M12 female molded connector, 22AWG conductors, overall braid shield.

## Component List - Transmitter Extension Cables

Designation	Ordering Information	Description
M12-C112	2TLA020056R2000	Extension cable, 1 meter, black PVC jacket with straight 5 pole M12 male/female connectors, 22AWG conductors, overall braid shield.
M12-C312	2TLA020056R2100	Extension cable, 3 meters, black PVC jacket with straight 5 pole M12 male/female connectors, 22AWG conductors, overall braid shield.
M12-C612	2TLA020056R2200	Extension cable, 6 meters, black PVC jacket with straight 5 pole M12 male/female connectors, 22AWG conductors, overall braid shield.
M12-C1012	2TLA020056R2300	Extension cable, 10 meters, black PVC jacket with straight 5 pole M12 male/female connectors, 22AWG conductors, overall braid shield.
M12-C2012	2TLA020056R2400	Extension cable, 20 meters, black PVC jacket with straight 5 pole M12 male/female connectors, 22AWG conductors, overall braid shield.
M12-C01	2TLA020055R1000	5 pole M12 female field retrofittable connector with screw terminals for connecting wires. Cable diameter range 2.5 - 6.5 mm.
M12-C02	2TLA020055R1100	5 pole M12 male field retrofittable connector with screw terminals for connecting wires. Cable diameter range 2.5 - 6.5 mm.
C5	2TLA020057R0000	5 conductors, 22AWG, black PVC jacket cable with overall braid shield. Per meter.

## Component List - Receiver Cables

Designation	Ordering Information	Description
M12-C63	2TLA020056R3000	Cable single ended 6 meters black PVC jacket with straight 8 pole M12 female molded connector, 22AWG conductors, overall braid shield.
M12-C103	2TLA020056R4000	Cable single ended 10 meters black PVC jacket with straight 8 pole M12 female molded connector, 22AWG conductors, overall braid shield.
M12-C203	2TLA020056R4100	Cable single ended 20 meters black PVC jacket with straight 8 pole M12 female molded connector, 22AWG conductors, overall braid shield.

## Component List - Receiver Extension Cables

Designation	Ordering Information	Description
M12-C134	2TLA020056R5000	Extension Cable, 1 meter, black PVC jacket with straight 8 pole M12 male/female connectors, 22AWG conductors, overall braid shield.
M12-C334	2TLA020056R5100	Extension Cable, 3 meter, black PVC jacket with straight 8 pole M12 male/female connectors, 22AWG conductors, overall braid shield.
M12-C03	2TLA020055R1600	8 pole M12 female field retrofittable connector with screw terminals for connecting wires. Cable diameter range 2.5 - 6.5 mm.
M12-C04	2TLA020055R1700	8 pole M12 male field retrofittable connector with screw terminals for connecting wires. Cable diameter range 2.5 - 6.5 mm.
C8	2TLA020057R1000	8 conductors, 22AWG, black PVC jacket cable with overall braid shield. Per meter.

## Component List - FMC/FMI Connector Cables

Designation	Ordering Information	Description
M12-C62	2TLA020056R0200	Cable single ended 6 meters black PVC jacket with straight 5 pole M12 male molded connector, 22AWG conductors, overall braid shield.
M12-C102	2TLA020056R1200	Cable single ended 10 meters black PVC jacket with straight 5 pole M12 male molded connector, 22AWG conductors, overall braid shield.

## Component List - Optional Interface Units

Designation	Ordering Information	Description
RT9-24VDC	2TLA010029R0000	Safety Relay with 2 safety outputs, 5 selectable input options (single or dual channel), automatic or manual supervised reset, test input for monitoring of external positive guided relays/contactors, 5 LED indicators, 1 dual purpose information output, quick release terminal blocks, 22.5mm wide, 24VDC supply. Meets safety category 1 to 4.
RT6-24VDC	2TLA010026R0000	Safety Relay with 3 safety outputs, 5 selectable input options (single or dual channel), automatic or manual supervised reset, test input for monitoring of external positive guided relays/contactors, 5 LED indicators, 1 NC information output and 2 potential free transistor information outputs, quick release terminal blocks, 45mm wide, 24VDC supply. Meets safety category 1 to 4.

## Component List - Optional Interface Units (continued)

Designation	Ordering Information	Description
RT6-115VAC	2TLA010026R0400	Safety Relay with 3 safety outputs, 5 selectable input options (single or dual channel), automatic or manual supervised reset, test input for monitoring of external positive guided relays/contactors, 5 LED indicators, 1 NC information output and 2 potential free transistor information outputs, quick release terminal blocks, 45mm wide, 115VAC supply. Meets safety category 1 to 4.
VITAL 1	2TLJ020052R1000	Safety Controller with 2 safety outputs, uses unique dynamic signal technology, automatic or manual supervised reset, test input for monitoring of external positive guided relays/contactors, 5 LED indicators, 1 dual purpose information output, quick release terminal blocks, 22.5mm wide, 24VDC supply. Meets safety category 4, dynamic self test.
PLUTO		See Pluto Safety PLC section for proper product selection.

## Focus II Ordering Data

### Safety Light Curtains

To create a complete Focus II Safety Light Curtain Part Number, simply fill in the fields below.

FII-4-      -       
(A)    (B)

**A** This letter represents the effective resolution of the Focus II Safety Light Curtain.

14	14mm (0.55") resolution for Finger Detection
30	30mm (1.18") resolution for Hand Detection

**B** This letter represents the protective height of the Focus II Safety Light Curtain.

150	150mm ( 5.91")	1350	1350mm (53.15")
300	300mm (11.81")	1500	1500mm (59.06")
450	450mm (17.72")	1650	1650mm (64.96")
600	600mm (23.62")	1800	1800mm (70.87")
750	750mm (29.53")	1950	1950mm (76.77")
900	900mm (35.43")	2100	2100mm (82.68")
1050	1050mm (41.34")	2250	2250mm (88.58")
1200	1200mm (47.24")	2400	2400mm (94.49")

### Safety Light Grids

To create a complete Focus II Safety Light Grid Part Number, simply fill in the fields below.

FII-4-K-       
(A)

**A** This letter represents the protective height of the Focus II Safety Light Grid.

4-900	4 beams spaced 300mm (11.81") apart with 900mm (35.43") protective height
4-1200	4 beams spaced 400mm (15.75") apart with 1200mm (47.24") protective height
3-800	3 beams spaced 400mm (15.75") apart with 800mm (31.50") protective height
2-500	2 beams spaced 500mm (19.69") apart with 500m (19.69") protective height

This document and any attachments may include suggested specifications, drawings, schematics and similar materials from ABB Inc. Use of such information and/or documentation by the recipient is subject to and conditioned upon your acceptance of the terms of the General Document Disclaimer which can be found at [www.jokabsafetyna.com](http://www.jokabsafetyna.com). Your acceptance of the terms of such General Document Disclaimer is conclusively presumed unless you notify ABB in writing of your disagreement with the terms of such Disclaimer immediately upon receipt of this document and you return to ABB all specifications, drawings, schematics and similar materials provided to you by ABB.



# Stop Time Analyzers

Monitor machine stop time!  
 Monitor machine stop distance!  
 Check machine for wear!



Why should I measure  
 Stopping Time and Distance? ..... 7:2

Smart Stopping Time and  
 Machine Diagnosis Tool ..... 7:3

Smart Manager Real-Time  
 Control Program ..... 7:4

Smart Units Technical Data..... 7:6

Component List and  
 Ordering Information ..... 7:8



# Why should I measure Stopping Time and Distance?

...to find out which safety arrangements can be used in a certain area around a machine and where they should be located!

## Stopping Time

The safety distance (how far away from the risk area a safety component must be placed) is based upon the machines stopping time. The basic idea is that a safety component should be placed so far from the risk area that it is not possible to enter the area before the machine has stopped.

The stopping time for manually operated machines is especially important when light beams and light curtains are used as safety components. By reflex action the operator tries to grab or adjust if something has gone wrong in the machine tool, even if the machine has started. It is then imperative that the machine stops before the hand reaches the risk area. A short stopping distance is also of importance for achieving good ergonomics.

Grabbing or adjusting is also common when using automatic machines. Usually this is done to prevent production downtime by quickly adjusting a work piece. The stopping time is also of great importance if someone trips and falls into the machine.

Stopping time, walking speed (1.6 m/s) and hand speed (2.0 m/s) is used for the calculation of safety distances. Sometimes a fixed minimum distance is also used. See the standard EN ISO 13855 for more details on the calculation of safety distances.

## Stopping Distance

For safety contact strips it is extra important that the stopping distance is monitored. An incorrect stopping distance could in many cases result in very high risks. The stopping distance is also needed during area limiting, e.g. for robots when dividing the working area into sectors.

For door sensitive edges, it is important that the stopping distance is shorter than the soft part of the sensitive edge.



*Where the safety distance is small, one can for example sit close to the machine and work, as in the picture on the left. If the safety distance is greater, it may be necessary to approach the machine to intervene, and also perhaps use additional protection to prevent starting when someone is within the protected distance, as in the picture on the right.*

### Example: How the stopping time affects the choice of protective equipment...

There was a case where we measured the stopping time of the rollers in a textile industry company. The company had planned to place light beams or a light curtain in front of the rollers to prevent the operators from being caught in the material and dragged in. The stopping time measurement showed that it took over one second for the rollers to stop. During this time the material was pulled in by almost two meters.

In order to obtain sufficient protection distance, the light beams would have needed to be positioned almost three meters from the machinery, and a light curtain about two meters away. The factory did not have that much space, nor was it realistic. Instead, the solution became vertical sliding safety barriers.

## Annual Checks

Wear in a machine is something that can affect braking and motors, which means that the stopping time of a machine can change with time. Certain other changes in a machine, such as changing the weight of a workpiece or alterations in pneumatic pressure, can also affect the stopping time. For these and other reasons it is important to perform an annual check on the stopping time.

## Regulations and Standards

It is also important to measure the stopping time, to meet the requirements set by the machinery standards, directives and regulations. Here we can help, with our long experience in the practical application of regulations and standards, from the viewpoints of both the authorities and production. In addition we collaborate with the standardization committees responsible for producing these standards. One example is EN ISO 13855, which deals with the placing of safety devices around

a machine based on its stopping time. The standard is general for all types of machinery, although for some, where there is a harmonized C standard, the requirements for minimum distance and stopping time measurement will apply. For example, in the case of mechanical press tools, there is also a requirement in EN 692 for how stopping time measurements are to be performed. In the case of hydraulic press tools, the requirement is in EN 693.

## Smart Stopping Time and Machine Diagnosis Tool

Smart has many valuable features for machine diagnosis:

- Graphic presentation of measurements
- Easy to analyze stopping characteristics and movement
- Gives parameters for safety design (e.g. stop time)
- Calculates minimum allowed safety distance
- Shows how the stop distance can be optimized
- Electrical reaction time and mechanical/hydraulic breaking can be identified and analyzed
- Digital in/out signals and analog inputs

Smart is perfect for periodic monitoring of safety parameters and other conditions for the maintenance and trouble-shooting of machines. Because Smart can compare old and new graphs, it becomes easy to find out the reasons for machine malfunctions. One can also supervise machines during operation and compare how they perform over time.

### Stopping Units and Sensors

Smart is a further development and replacement of our well established JSSM1 Stopping Analyzer. All of the stopping units and sensors for the JSSM1 can also be used with Smart.

The amount of connection possibilities have also increased. Smart has nine digital I/O, one input for an incremental sensor (for position and speed) and two analog inputs. This makes it easy to measure sequences in conjunction with motion lapse and other analog values.

### Web Support

On our web site [www.jokabsafety.com](http://www.jokabsafety.com) we have a special page for you as a Smart customer. Here you can keep up to date by downloading the latest version of Smart Manager, manuals, drive routines or read the FAQs.

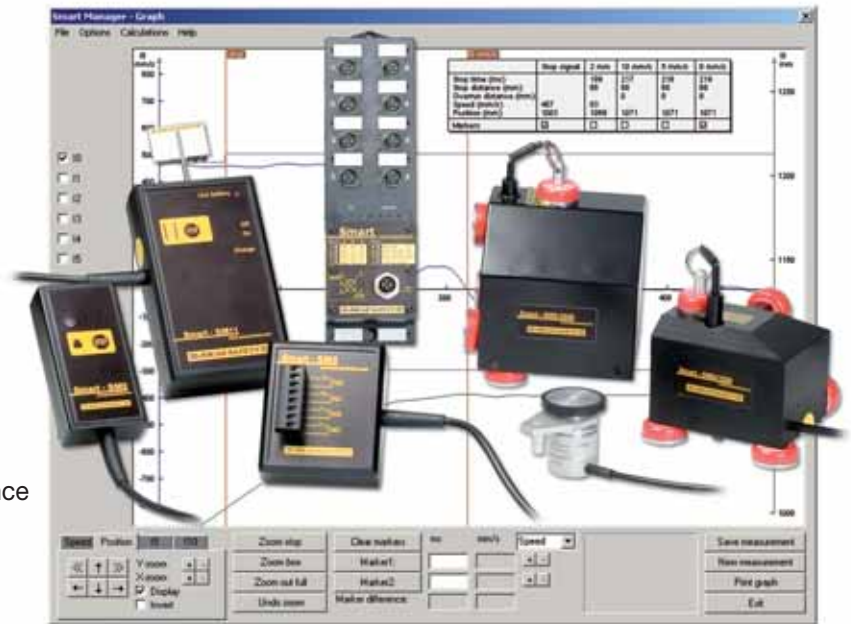

### Applications

- Stopping Time
- Stopping Distance
- Speed
- Position of Stopping Signal

### Features

- Easy to use
- Measurements with or without electrical connection
- Ideal for machine performance diagnosis
- Calculation of correct safety distances

### Approvals



# Smart Manager Real-Time Control Program

Smart is controlled in real time by a computer using the Smart Manager program. This performs measurements, and the measured data can be saved and analyzed. The measurements are saved in an SQL database, with the ability to export data to Microsoft Excel if necessary.

The program calculates the stopping time and protective distance, and can print out the results, together with a graph of the event sequence.

The program is free and is available for download from our website when purchasing equipment to measure stopping times.

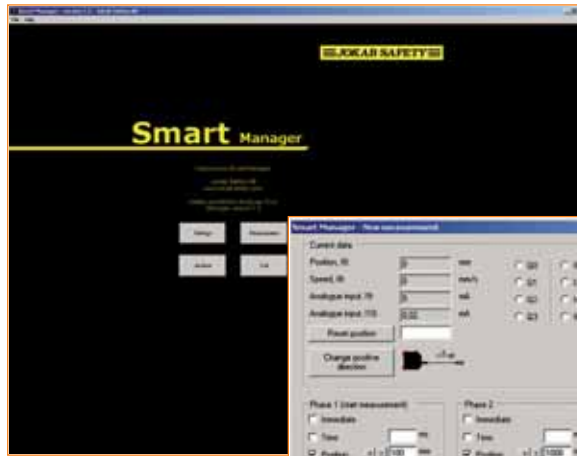

Start Menu

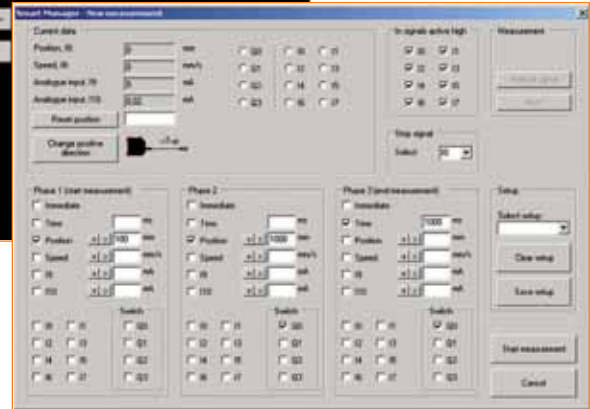

Measuring Form

- Current values from sensors and the system
- Shutdown conditions
- Start conditions
- Measuring settings can be saved
- Stop signal conditions

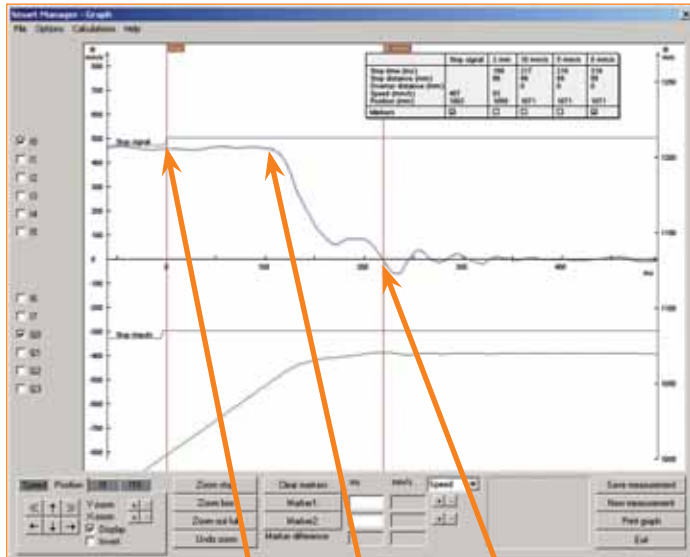

Measured Results

- Stop time data
- Zoom control
- Own cursors

Stop signal given

Relay contacts drop out

Machine stopped

## Features

- Simple program structure
- Shows the entire stop sequence
- Provides a machine movement “fingerprint”
- Compares measurements
- Calculates stopping time
- Saves measurements to a database
- Exports measured data to Excel
- Prints out a complete measurement report

## System Requirements

- Windows XP/2000/Me/NT
- 100 MB free disk space



## Calculations

- Minimum, maximum and average value and standard deviation from series of measurements
- Protective distance can be calculated



## Saving Your Measurements

- Select measurement series
- State extra information, e.g. the conditions and special circumstances for the measurements



### Archiving

- Search filter
- Saved measurements
- Exported measurements



### Conversion of Analog Signals

Smart can measure and show graphs for two different analog sensors at the same time, with its inputs for 0/4-20 MA.

Conversion of the measured current values can be done automatically by setting minimum and maximum values and the units for the inputs.

In this way, for example, the results from an analog pressure sensor can be shown and calculated as 0-400 bar instead of 4-20 mA, or an analog load cell as 0-2 kN.

This also means that if it is desired for the system to be triggered at a certain force, that force can be defined instead of needing to calculate the equivalent current value.

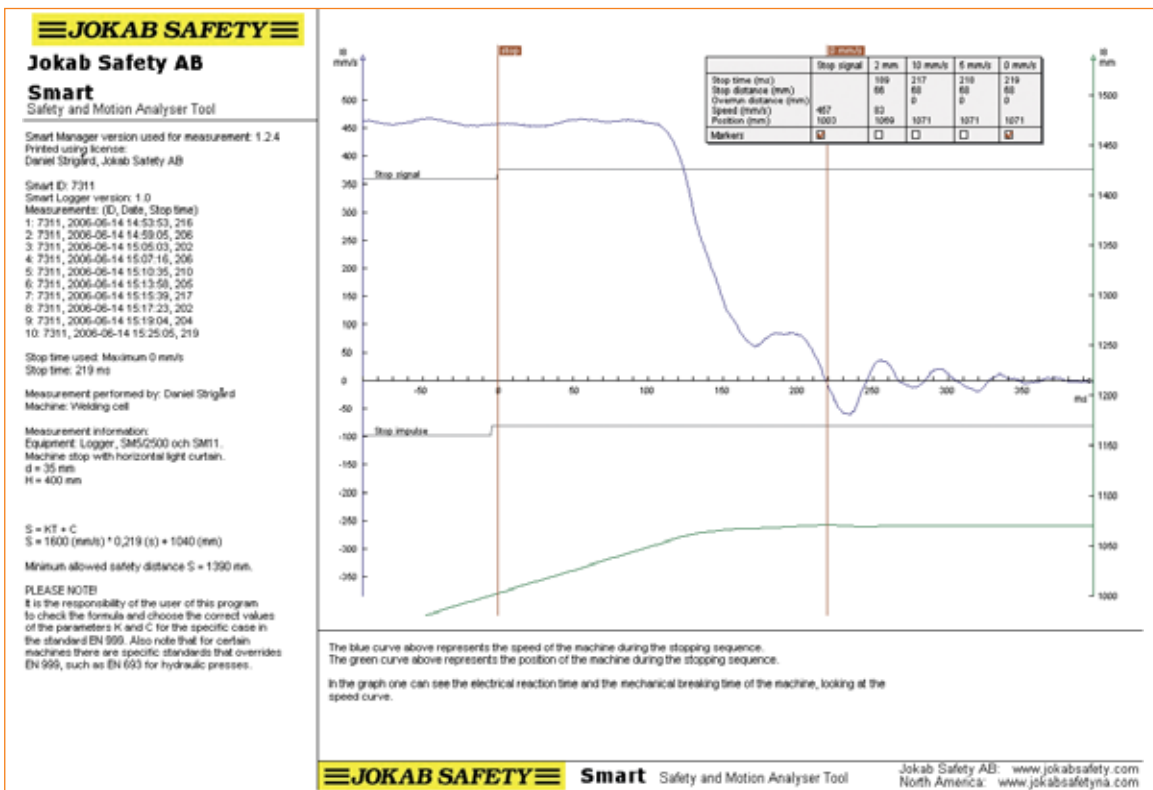

### Printout

Printing out is one of the most important functions of the program. As shown above, all the vital information about the measurements that is needed for such items as annual checking or providing the basis for CD labeling of a machine is included.

Since the entire measuring sequence is shown in graphical format, one can understand why the stopping time has a certain value and also, in some cases, see what needs to be done to minimize the stopping time.

The graph also acts as a kind of "fingerprint" of the machine movements, which means that different measurements can be compared with each other to see how the

stopping sequence varies from time to time or from year to year. In this way the effects of e.g. worn brakes or the effect on the machine control system can be seen. In order to get a complete basis from a measurement, it is also important to state what assumptions have been made and what conditions applied when deciding when and how the stop signal was given.

Among other things, the stop signal details the person measuring, the measuring equipment, the machinery, the calculations and the protective distance. The printout also has a replaceable company logo and a field for extra information.

## Smart Units Technical Data

### Smart Logger

The Smart Logger is the principal unit for data collection. The Logger has a USB connection to the PC and eight M12 connections—one for the power supply to the I/O, one connection for an incremental sensor, two connections for analog sensors and four connections for other I/O signals.

The Logger encapsulation is watertight, with M12 connections to prevent the entry of particles and fluids in the workshop environment. To prevent the Smart Logger from being damaged by incorrect currents and voltages from external equipment, all inputs and outputs, and external units, are electrically isolated from the processor in the Smart Logger by means of opto-couplers.



Manufacturer	ABB AB/Jokab Safety, Sweden
Ordering information	2TLJ070300R0100 see page 7:8 for accessories
Dimensions	62 x 220 x 80 mm (WxHxD)
Weight	0.5 kg
Protection class	IP 67
Supply voltage	24 VDC
Response speed	max 1 ms
Positional accuracy	+/- 0.1 mm
Digital I/O	8 inputs, 4 outputs (NPN OC)
Analog inputs	2 off, 0/4-20 mA
Encoder	1 connection for a pulse sensor

### SM2 Button Unit

The SM2 is used in conjunction with the Smart Logger for measuring with a manual stop impulse, without an electrical connection to the machine. When an SM2 is, for example, pressed against an emergency stop button to stop the machine, the SM2 sends a signal to the Smart Logger to start the measurement. An LED on the SM2 lights when the desired stop position is reached. The SM2 is connected to the Smart Logger by an M12 connection.



Manufacturer	ABB AB/Jokab Safety, Sweden
Ordering information	2TLJ070300R0200 see page 7:8 for accessories
Dimensions	50 x 100 x 25 mm (WxHxD)
Weight	0.2 kg
Application area	Two-handed control unit, Emergency stop, etc.
Supply voltage	Fed from the Smart Logger

### SM3 Relay Unit

The SM3 is used in conjunction with the Smart Logger for automatic stopping time measurements at the set position, or alternatively a manual stop pulse. When a stop signal comes from the Smart Logger, a relay switches in the SM3. The SM3 then sends a signal to the Smart Logger to start measuring, and also activates the relay outputs to stop the machine. The relay in the SM3 is reset via the software when a new measurement is to be made. The SM3 is connected to the Smart Logger by an M12 connection.



Manufacturer	ABB AB/Jokab Safety, Sweden
Ordering information	2TLJ070300R0300 see page 7:8 for accessories
Dimensions	85 x 72 x 49 mm (WxHxD)
Weight	0.2 kg
Application area	Electrical connection providing a stop pulse
Supply voltage	Fed from the Smart Logger
Relay outputs	2 NO, 2 NC, 6A/250 VAC.
Encoder	1 connection for a pulse sensor

### SM11 Flag Unit

The Smart Logger is used in conjunction with the SM11 for automatic measurements of the stopping time and stopping distance. The unit is located in a light curtain with the flag parallel to the beam. When the flag is activated, the light beam or light curtain is interrupted, and the machine stops. Installation on a table or a standard 1/4" camera tripod is suitable. The SM11 is connected to the Smart Logger by an M12 connection.



Manufacturer	ABB AB/Jokab Safety, Sweden
Ordering information	2TLJ070300R1100 see page 7:8 for accessories
Dimensions	145 x 85 x 37 mm (WxHxD)
Shaft	ø3 x 45 mm
Weight	0.6 kg
Application area	Light curtain, light beam
Protection class	IP 40
Batteries	10 rechargeable 1.2 V NiMH batteries, total 12 V
Power	Max 1200 mAh (approximately 200 operations)
Temperature	0 to +45°C.
Installation	Table or standard 1/4" tripod
Charger	SM14

## Smart Units Technical Data (continued)

### SM5 1250/2500 Linear Sensor

The SM5 is an incremental pulse sensor for connection to a Smart Logger. The sensor is protected by a robust enclosure. The sensor and end of the cable are secured to the machine by powerful magnets.

The SM5 is connected to the Smart Logger by an M12 connection.



Manufacturer	ABB AB/Jokab Safety, Sweden
Ordering information SM5/1250 SM5/2500	see page 7:8 for accessories 2TLJ070300R0400 2TLJ070300R0500
Dimensions SM5/1250 SM5/2500	106 x 88 x 100 mm (WxHxD) 114 x 125 x 116 mm (WxHxD)
Weight SM5/1250 SM5/2500	SM5/1250: 1 kg 1.4 kg
Application area	Linear movement, e.g. press tools
Supply voltage	Fed from the Smart Logger
Max length	1250 or 2500 mm
Max speed	5 m/s
Resolution	0.1 mm

### SM7 Rotation Sensor

The SM7 is an incremental sensor for connection to a Smart Logger. The sensor detects rotational movement via a wheel rolling against a shaft. The Stand secures the sensor with the aid of just one knob. The stand itself is secured to the machine by a powerful magnetic foot. The SM7 is connected to the Smart Logger by an M12 connection.



Manufacturer	ABB AB/Jokab Safety, Sweden
Ordering information	2TLJ070300R0700 see page 7:8 for accessories
Dimensions Sensor size Stand size, extended	46 x 40 x 59 mm (WxHxD) approx. 400 x 50 x 90 (WxHxD)
Weight	1.7 kg including stand
Application area	Rotating motion, e.g. lathes, rollers
Supply voltage	Fed from the Smart Logger
Max speed	5 m/s
Resolution	0.1 mm
Wheel circumference	125 mm

### SM13 Battery Pack

SM13 is a battery pack for the Smart Logger, which makes the Smart a completely mobile measuring tool. With the SM13 you don't need to connect the Logger to a wall socket for power, and can easily move it from one machine to another when you are measuring. Since the SM13 battery pack is the same physical size as the SM11 flag unit, it fits snugly into the SM9 carrying case. The charger for the SM13 is called the SM14 and provides a charging time of about 3 hours, 15 minutes (2100 mAh). The SM14 also acts as a fast charger for the SM11.



Manufacturer	ABB AB/Jokab Safety, Sweden
Ordering information	2TLJ070300R2300 see page 7:8 for accessories
Dimensions	145 x 85 x 37 mm (LxWxH)
Weight	0.8 kg
Protection class	IP 40
Connector	Negative pole at the center of the charging connector
Current rating	Maximum 0.9A
Power	2100 mAh. With normal use lasts about 10-12 hours (higher capacity on request)
Batteries	20 rechargeable 1.2 V NiMH batteries of size AA(R06). Total 24 V

### SM9 Carrying Case

The SM9 is a practical carrying case with pockets to suit the various Smart units. Part of the protective foam insert in the lid of the case can be removed to make room for a laptop computer, so that all the equipment required can be carried in a single case.



Manufacturer	ABB AB/Jokab Safety, Sweden
Ordering information	2TLJ070300R0900 see page 7:8 for accessories
Dimensions	535 x 155 x 430 mm (LxWxH)
Weight	3.5 kg

## Component List - Smart Accessories

Designation	Ordering Information	Description
SM6	2TLJ070300R0600	AC/DC converter for Smart.
Encoder Adapter	2TLJ070300R1300	Adapter for old type JSSM sensor.
Stop Unit Adapter	2TLJ070300R1400	Adapter for old type JSSM stop units.
USB Cable	2TLJ070300R1500	USB cable for communication from computer to Smart.
JSNA-AC-Cord	2TLA850007R0500	AC power supply cord for Smart.
SM12 Charger Unit	2TLA850007R0600	Small Charger Unit for North America used with the SM11 Flag Unit.
SM14	2TLJ070300R2400	Charger for flag unit SM11 and battery pack SM13.
Extension Cables	2TLJ020056R2000 2TLJ020056R2100 2TLJ020056R2200 2TLJ020056R2300 2TLJ020056R2400	ABB Jokab Safety's extension cables with 5 conductors ideal for all Smart accessories.

## Component List - Smart Kits

Designation	Ordering Information	Description
JSNA-SMART Complete Smart Kit	2TLA850007R0000	Complete Kit, includes Smart Logger, Smart Software, USB 2 cable, SM6 Power Supply with cord, SM2 Button Unit, SM3 Relay Unit, SM11 Flag Unit, SM5 2500 Linear Sensor, SM7 Rotation Sensor, SM12 Charger Unit and SM9 Carrying Case.
JSNA-SMART-LP1 Linear Press Kit 1	2TLA850007R0100	Linear Press Kit 1, includes Smart Logger, Smart Software, USB 2 cable, SM6 Power Supply with cord, SM2 Button Unit, SM11 Flag Unit, SM5 1250 Linear Sensor, SM12 Charger Unit and SM9 Carrying Case.
JSNA-SMART-LP2 Linear Press Kit 2	2TLA850007R0200	Linear Press Kit 2, includes Smart Logger, Smart Software, USB 2 cable, SM6 Power Supply with cord, SM11 Flag Unit, SM5 2500 Linear Sensor, SM12 Charger Unit and SM9 Carrying Case.
JSNA-SMART-RP Rotary Press Kit	2TLA850007R0300	Rotary Press Kit, includes Smart Logger, Smart Software, USB 2 cable, SM6 Power Supply with cord, SM2 Button Unit, SM11 Flag Unit, SM7 Rotation Sensor, SM12 Charger Unit and SM9 Carrying Case.
JSNA-SMART-TC Tooling Cell Kit	2TLA850007R0400	Tooling Cell Kit, includes Smart Logger, Smart Software, USB 2 cable, SM6 Power Supply with cord, SM2 Button Unit, SM3 Relay Unit, SM11 Flag Unit, SM5 2500 Linear Sensor, SM12 Charger Unit and SM9 Carrying Case.

This document and any attachments may include suggested specifications, drawings, schematics and similar materials from ABB Inc. Use of such information and/or documentation by the recipient is subject to and conditioned upon your acceptance of the terms of the General Document Disclaimer which can be found at [www.jokabsafetyna.com](http://www.jokabsafetyna.com). Your acceptance of the terms of such General Document Disclaimer is conclusively presumed unless you notify ABB in writing of your disagreement with the terms of such Disclaimer immediately upon receipt of this document and you return to ABB all specifications, drawings, schematics and similar materials provided to you by ABB.



# Safety Sensors and Switches

Meet existing safety standards!  
Supervise doors and hatches!  
Safe stops and reliable restarts!



Why should I use Safety Sensors and Switches? .....	8:2
Eden provides the Highest Safety Level and Reliability .....	8:3
How safe is a Sensor/Switch? .....	8:3
Eden Non-Contact Safety Sensor .....	8:4
SafeSlide™ Safety Lockout System .....	8:8
JSNY5 Safety Interlock Switch .....	8:10
JSNY7 Magnetic Switch .....	8:12
Solenoid Locking Safety Interlock Switches	
JSNY8 .....	8:14
JSNY9 .....	8:16
Magne 1A/2A Magnetic Lock with Indication .....	8:18
Knox Safety Lock .....	8:24
Component List and Ordering Information .....	8:28

# Why should I use Safety Sensors and Switches?

## ...to supervise doors and hatches around dangerous machines!

Assurance that a machine stops when a door or a hatch is opened can be solved by using different types of switches and sensors which are monitored with a Safety Relay, Vital 1 or Safety PLC. Switches and sensors are available both as non-contact (dynamic or magnetic) and various types of interlocking devices. Interlocking devices can be used when it is required, via a signal, to lock a gate during processes that cannot be stopped during certain operations. They are also used with machines that have a long stopping time.



## ...to manage safety in harsh environments!

Non-contact dynamic sensors have a long life-time because they are not physically mechanically operated. They also endure very harsh environments (i.e. cold, heat, high-pressure wash-down) which is important in the food industry. Because the sensors are small, they are very easy to position and even completely conceal on doors and hatches.



## ...to ensure that a position is reached!

The sensor monitors that the robot is standing still in a monitored position when someone enters the robot's working area. The robot is then only stopped by the program. If the robot leaves the position, the power will directly be cut. This is used when the robot does not stop safely without restarting problems.

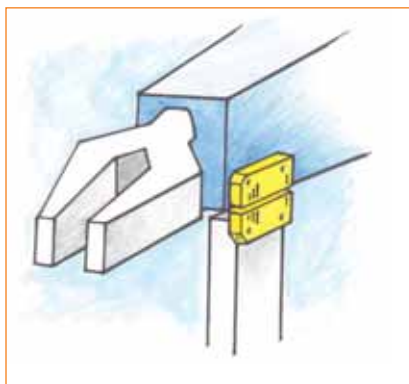

## Eden provides the Highest Safety Level and Reliability

Our recommendation is to use the Eden sensor because it is the safest and most reliable solution. The Eden sensor is both a non-contact switch and it has a dynamic function. It is also possible to connect up to 30 Eden sensors in series and still achieve a safety category 4.

### What requirements should one have on sensors/switches?

The sensor/switch shall be reliable in both the safety and production point of view.

- A person must be able to trust that dangerous movements and functions are safely stopped by the sensors/switches.
- In the production point of view, unintentional stops should be avoided.

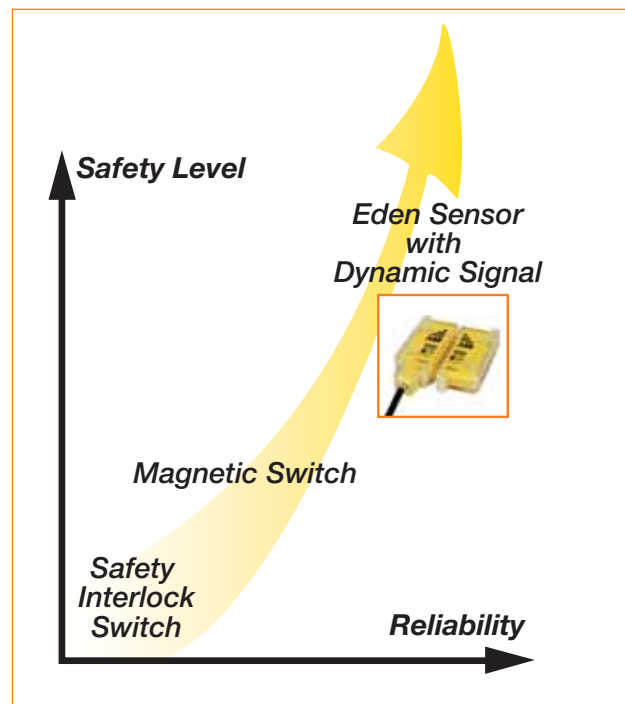

## How safe is a Sensor/Switch?

*In order to trust the safety function, it is essential to be aware that a safety sensor/switch must be mounted and used according to the specifications. The certification authorities only test the product according to the appropriate standards and to the specifications from the manufacturer.*

### Mechanical Switches

For mechanical switches (e.g. key operated), a door or hatch has to be constructed to small tolerances in order for the switch, the key or the mounting brackets to last according to the life time specification from the supplier. The screws holding the parts have to be locked in such a way that they cannot be loosened. In order to prevent material from getting into the slot for the key, the environment has to be clean.

If a door goes outside the design tolerances from wear, the screws loosen or material comes into the slot, this may lead to the interlocked switch not giving a stop signal when the door is opened. Even two mechanical switches on a door could break to an unsafe state if the door somehow gets outside the tolerances of the switches. To prevent accidents the mechanical switch normally needs continuous checks of both the switch and the installation.

### Non-Contact Sensors/Switches

For non-contact sensors the risks associated with mechanical switches do not exist. If screws, brackets or sensors get loose, it will lead to a stop signal. Therefore only one sensor with dual or dynamic function is needed in order to reach the highest safety level.

There are two types of non-contact sensors—active and passive. The active sensor, Eden, is constantly communicating with a dynamic signal between the two parts and any failure will directly lead to a stop signal. The passive type, a magnet switch, has two reed contacts which are activated by a coded magnet. Both the passive and the active sensors are checked every time a door is opened. From a safety point of view, the active sensor, Eden, is preferred because it is checked constantly whereas the passive sensor is only checked when a door opens.

From the reliability point of view, a long detection distance with large tolerances and a well-defined on and off position is needed. The active sensor, Eden, fulfills these demands. A magnet switch has smaller tolerances and an intermediate position where only one contact opens. A bad installation or vibrations can lead to an unintentional stop if one contact opens and closes again. The supervision of a two-channel system is based on both contacts having to be operated in order to permit a new start. In a dynamic safety circuit, there is only one pulsed signal and therefore no intermediate position.

# Eden Non-Contact Non-Magnetic Safety Sensor for the Highest Level of Safety

Eden—Adam and Eva—is a non-contact safety sensor for use on interlocked gates, hatches, etc. A coded signal is transmitted from the control device Vital or from the safety PLC Pluto via Adam to Eva, which modifies the signal and sends it back again. The maximum sensing distance between Adam and Eva is currently 15mm +/- 2 mm.

Up to 30 Edens can be connected in series to Vital and still achieve the same safety level in the safety circuit. It is also possible to connect safety light beams and E-stops in the same safety circuit.

Adam is available with cable lengths up to 20 m and with M12 connectors. The LED on Adam provides indication of four different conditions, contact/non-contact between Adam and Eva, alignment, and safety status. The same information is also available via the Adam connection cable. For harsh environments, ABB Jokab Safety offers Eden E—Adam E and Eva E.

## Flexible Mounting

The ability to operate at distances of up to 15mm and at different detection directions allows a wide range of mounting possibilities.

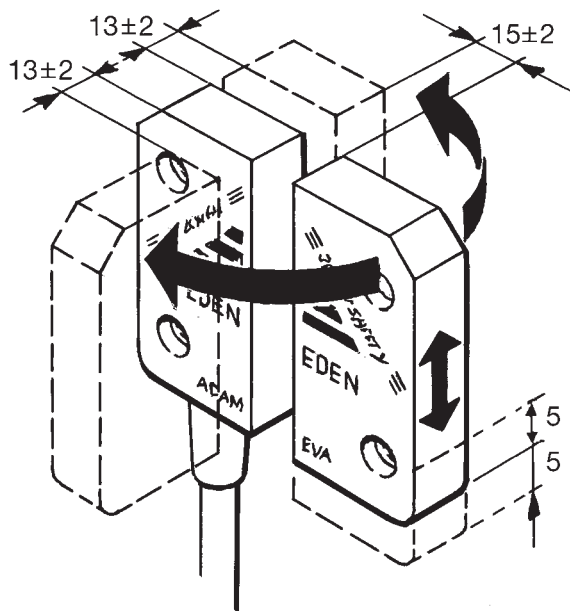

Eden E for harsh environments



## Applications

- Doors and Hatches
- Position Control
- Sector Detection
- Slot Detection

## Features

- Safety category 4 according to EN 954-1/EN ISO 13849-1 together with Vital or Pluto
- Non-contact detection, large sensing distance 0 - 15 mm +/- 2 mm
- Up to 30 sensors connected in series at safety category 4
- Versatile mounting, 360° detection
- Protection class IP67 (Eden E - IP69K)
- Signal will penetrate through non-metallic materials (wood, plastic, etc.)
- Safety light beams, E-stops and Eden can be connected in the same safety circuit together with Vital or Pluto meeting safety PLe according to EN ISO 13849-1
- LED indication on sensor and status information via the connector cable
- Small hysteresis (< 1mm)

## Approvals

TÜV Nord  

## Eden Application Examples

### Eden to Detect Position

Adam and Eva has contact only if they are within 15 mm from each other.

### Eden Used for Sector Detection

Metal stops the signal between Adam and Eva. Additional Eden sensor(s) can be mounted to detect metal plate(s) in place.

### Eden Used for Detection of Position of Saw Guard

Wood, plastic and other non-metallic material lets the signal pass between Adam and Eva.

### Eden Hidden in Doors and Hatches

Non-metallic door material between Adam and Eva allows signal through.

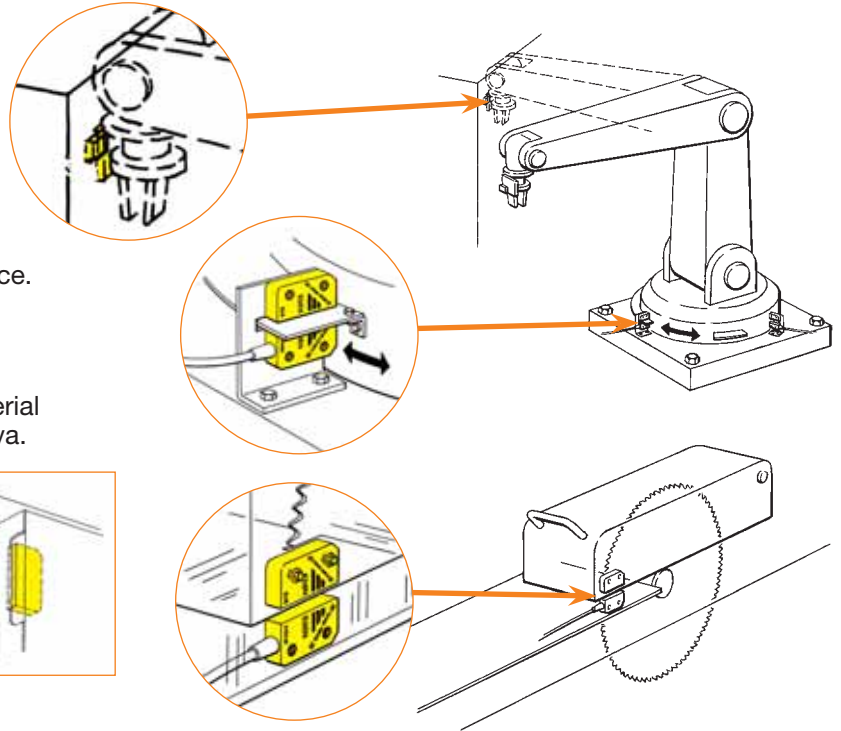

## Eden Mounting

Mounting Adam with integral cable.



Mounting with one protection plate (DA1) for Adam M12 using prewired molded M12 connector.



Mounting with two protection plates (DA1) for Adam M12 using field wirable M12 connector.

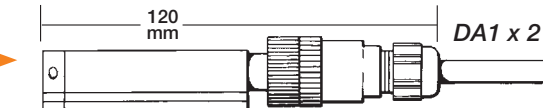

Incorrect mounting without protection plate may cause permanent damage to sensor.

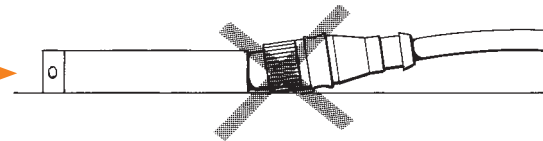

### DA2 Mounting Spacer

The DA2 mounting spacer must be used in order to physically protect Eden from damage. Four spacers are provided with each Adam and Eva.

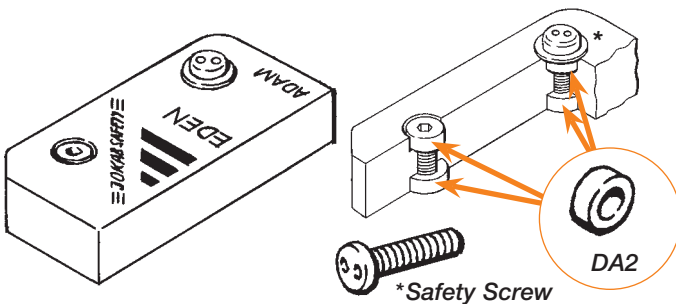

### DA1 Protection Plate

Four protection plates (2.5 mm) are supplied with Adam M12. To protect Adam and Eva protection plate (DA1) can be used on both sides.

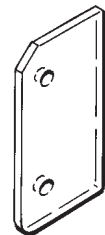

## Eden Technical Data

Manufacturer	ABB AB/Jokab Safety, Sweden	
Ordering information	see pages 8:28 - 8:30	
Safety level IEC/EN 61508-1...7 EN 62061 EN ISO 13849-1	SIL3 SIL3 Cat. 4/PL e	
PFH <sub>d</sub>	4.50×10 <sup>-9</sup>	
Color	Yellow and black	
Weight		
Eva	26 g	
Eva E	36 g	
Adam M12	30 g	
Adam 3 m	220 g incl. cable	
Adam 10 m	650 g incl. cable	
Adam 20 m	974 g incl. cable	
Adam E10 m	660 g incl. cable	
Adam E20 m	1250 g incl. cable	
Adam E 0.5 m + M12	100 g incl. cable	
Power supply	24VDC +15%-25%	
Power consumption	Adam: without info output 45 mA with info output max 55 mA	
Max cable length	see Vital technical data	
Ambient temperature Eden/Eden C	-40°C ... +70°C (operation) -25°C ... +70°C (stock)	
Eden E/EC	-40°C ... +70°C (operation) (Test ok +90°C ... +100°C) -25°C ... +70°C (stock)	
Protection class Eden Eden E	IP67 IP69K	
Mounting Installation Eden	M4 screw, e.g. safety screw 20-053-42. Max. torque 2 Nm. Screw to be locked with Loctite or similar	
Installation Eden E	M4 screw, e.g. safety screw 20-053-42. Max. torque 2 Nm. Screw to be locked with Loctite or similar	
Detection distance max Adam/Eva 15 ± 2 mm Adam E/Eva E 12 ± 2 mm Hysteresis approx. 1 mm	Flash 2 mm before red position Flash 2 mm before red position	
Metal may have influence on detection distance. This can be prevented by protection plates, DA1		
Minimum distance to metal when there is metal on one or more sides.		
Adam/Eva	One	More
Adam E/Eva E	0 mm	2.5 mm
Adam E/Eva E	0 mm	0 mm
Minimum distance between Eden pairs	50 mm	
Life	>10 <sup>7</sup> cycles	
Material	Macromelt (Based on polyamid) Eden E for extreme surroundings	
Cable	3 or 10 m, ø 5.7mm, black, PVC 5 x 0.34mm <sup>2</sup> + screen, UL 2464	
Connector	M12: 5-pin male contact	

Chemical resistance Macromelt	Cutting oils, vegetable and animal oils, hydrogen peroxide, diluted acids and bases: good Alcohol and strong acids: not recommended
PU (EdenE)	Cutting oils, vegetable and animal oils, hydrogen peroxide, diluted acids and bases, alcohols: good Strong oxidating acids: not recommended
LED on Adam Green	Eva within range, safety circuit closed (door closed)
Flashing	Eva within range, earlier safety circuit open (door closed)
Red	Eva out of range, safety circuit open (door open)
Fast flashing	Eva is within 2 mm from maximum sensing distance (door closed)
Connections	
Brown (1)	+24 VDC
White (2)	Dynamic signal in
Blue (3)	0 VDC
Black (4)	Dynamic signal out
Grey (5)	Info output, see below
24 VDC when LED is green or flashing (tolerance -2 VDC), 10 mA max 0 VDC when LED is red. (tolerance +2 VDC)	
<b>Warning:</b> Incorrect connection may cause permanent damage to Adam devices	
Conformity	2006/42/EG EN ISO 12100 1/2, EN 954-1, EN 60204-1, EN ISO 13849-1, EN 1088, GS-ET 15
Approvals	TÜV Nord 

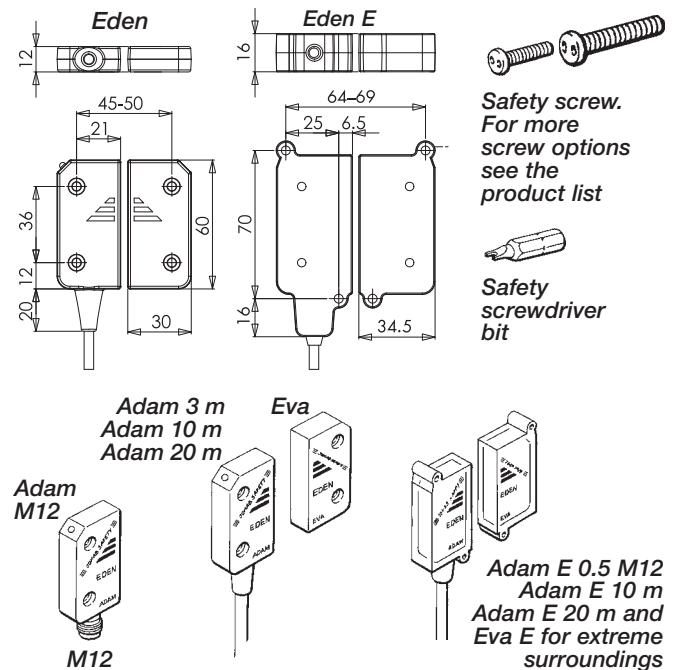

# Eden Connection Example

## Connection of Eden to Vital 1

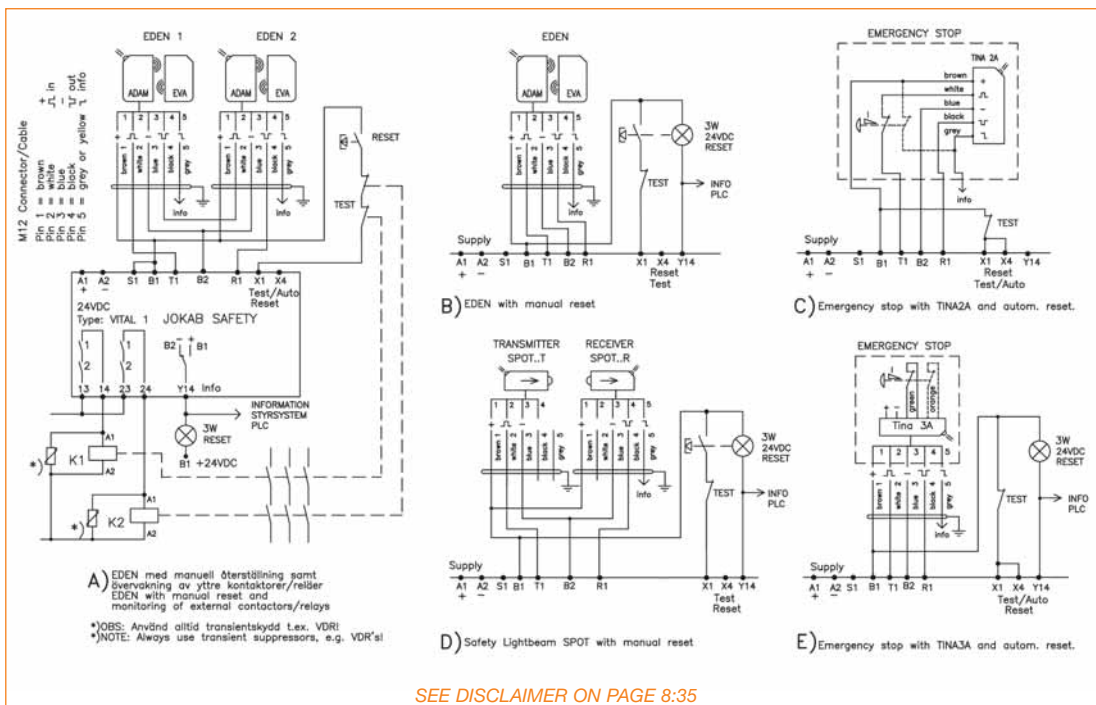

# Eden Connection Example

## Connection of Eden to Pluto

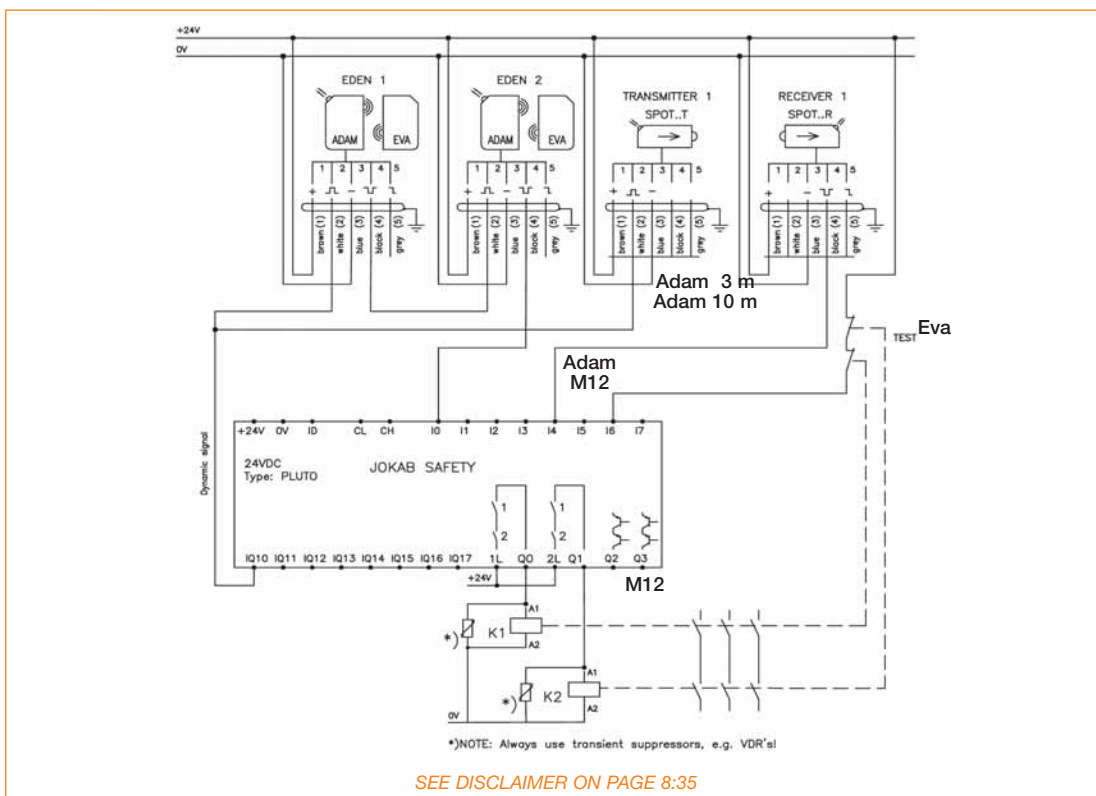

# SafeSlide™ Safety Lockout System

SafeSlide, a unique Safety Lockout System, was designed and developed by ABB Jokab Safety North America to be used in conjunction with ABB Jokab Safety's Eden non-contact, non-magnetic electronic safety sensor.

The product is engineered to be installed on doors, gates and hatches of all types used on machine guarding, barrier and fencing systems to provide safe entry and exit.

When the SafeSlide is engaged while the door is open and secured with a single or multiple padlocks, the system prevents the door from inadvertently closing which would cause the Eden Adam and Eva to reestablish contact creating an unsafe situation.

When the SafeSlide is engaged while the door is closed, it slides down over the flange on the bracket attached to the door and secures the door until the SafeSlide is disengaged.

The handle on the front of the slide allows for opening of the door, gate or hatch from the outside of the guarded area and a metal tab allows opening from the inside.



*When SafeSlide is engaged it completely eliminates the possibility of the Eden Adam and Eva making contact. A simple padlock can secure the position for further safety.*



*With the door closed and SafeSlide engaged, the Eden Adam and Eva are able to make contact and the door is secured.*



*With the door open and SafeSlide engaged, the Eden Adam and Eva are unable to make contact preventing an unsafe situation.*

## Applications

- Hinged or Sliding Doors, Hatches and Gates for Machine Guarding, Barrier and Fencing Systems

## Features

- Lock out holes for padlocks and scissor type lockout devices
- Mounting holes to accommodate installation of Eden—Adam and Eva Safety Sensor
- Adjustable slots for door, gate or hatch gap differences
- Upper slide with handle provides an automatic or manual lock cover upon opening of door gate or hatch
- Tabs located on device allow for wire and cable connections the the Eden switches
- Slots provided to allow viewing of LEDs located on the switches



## SafeSlide Technical Data

<b>Manufacturer</b>	ABB/Jokab Safety, North America
<b>Ordering information</b>	see page 8:30
<b>Color</b>	Yellow and black
<b>Weight</b>	1.9 kg
<b>Mounting</b>	Quick-Guard Fencing Profile (can be mounted to other handles or locking devices)
<b>Material</b>	Steel with UHMW slide block

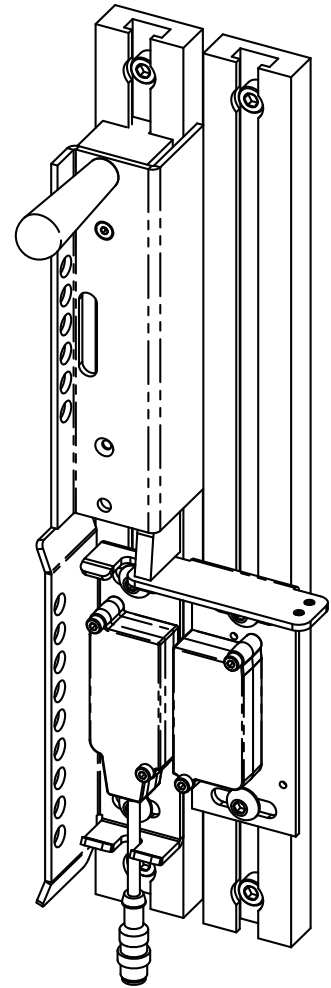
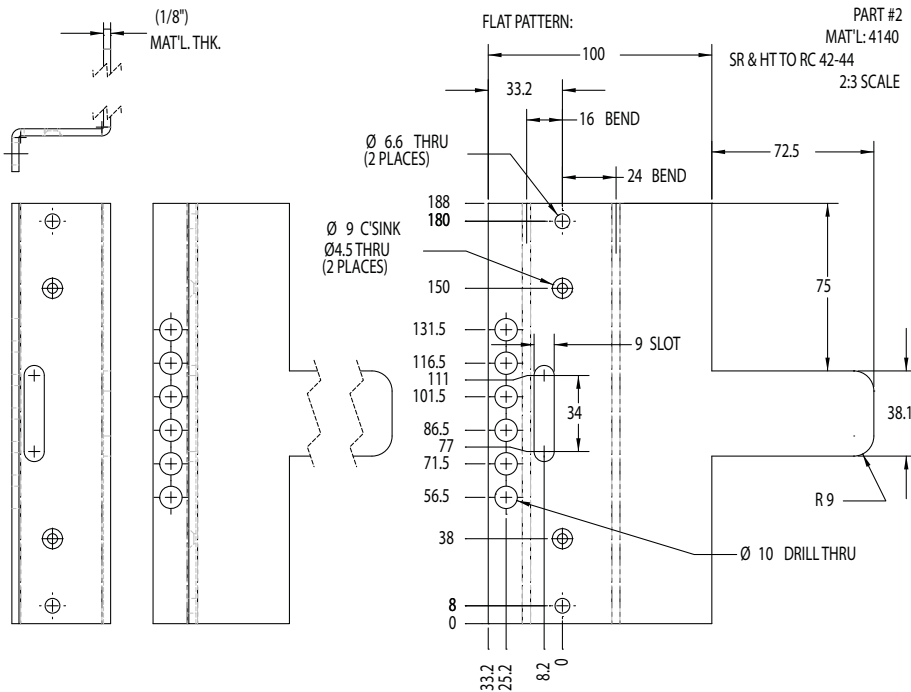

## SafeSlide Isolates Hazardous Motion and Offers Control Reliability during Non-Lockout/Tagout Applications

SafeSlide meets safety standards that apply to the control of energy during servicing and/or maintenance of machines and equipment.

Normal production operations are not covered by OSHA 1910 - Subpart O - Lockout/Tagout. Servicing and/or maintenance which takes place during normal production operations is covered by this standard only if one of these situations occurs:

- An employee is required to remove or bypass a guard or other safety device
- An employee is required to place any part of his or her body into an area on a machine or piece of equipment where work is actually performed upon the material being processed (point of operation) or where an associated danger zone exists during a machine operating cycle.

Minor tool changes and adjustments, and other minor servicing activities, which take place during normal production operations, are not covered by this standard if they are routine, repetitive and integral to the use of the equipment for production, provided that the work is performed using alternative measures which provide effective protection.

# JSNY5 Safety Interlock Switch

## Switch Operational Description

Increasing automation and more demanding safety regulations have led to the development of the JSNY5 safety switch. This switch enhances the range of Safety Switches, incorporating advanced features and benefits making this switch a market leader. This switch offers three contacts which gives both the two contacts needed for high safety level as well as a contact for the indication of operating status.

The advanced design offers the choice of four operating positions from only two actuator entries by simply rotating the head 180°.

However, when installed and in its working condition only one entry can be used, ensuring no other element can tamper with the switch function.

When mounting the switch from the front two elongated holes are provided to aid alignment with two set screw holes for accurate mounting. Top mounting is also possible.

Two M20 cable entries allow for a variety of cabling options including through wiring.

## Positive Forced Disconnected Contacts

The design assures that the contacts will not fail or be held in a normally closed position, due to failure of the spring mechanism or the welding/sticking of the contacts.

## Safety Level

The positive forced disconnect contacts give a high electrical safety level. By combining the JSNY5 with one of our suitable safety relay in the RT-series, Pluto Safety PLC or Vital (Tina) the requirements for both hatch and gate switch supervision can be fulfilled. To obtain the same level of safety as Eden, two switches per gate are required.

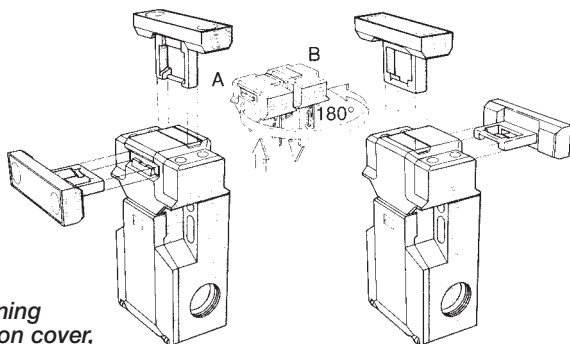

After opening the snap-on cover, the head portion can be removed (version A), after turning the head through 180° (version B) it can be replaced onto the body of the switch and be locked into position by closing the snap-on cover. This ensures 4 actuating positions are possible.



## Applications

- Gates and Hatches
- Removable Cover

## Features

- 2 NC + 1 NO (actuator in)
- 4 actuating positions
- Actuator force 10 or 30 N

## Protection from Unauthorized or Incidental Access

To avoid unauthorized operation, the JSNY5 switch is manufactured using multi-coding to GS-ET 15. The switch cannot be defeated by screwdrivers, magnets or any other mechanism.

## Connection Examples

For examples of how our safety switches can solve various safety problems, see "Connection Examples" beginning on page 4:44 of the Safety Relay Section.

## Regulations and Standards

The JSNY5 is designed and approved in accordance with appropriate directives and standards. Examples of such are: 98/37/EC, EN ISO 12100-1/-2, EN 60204-1 and EN 954-1/EN ISO 13849-1, EN 1088 and GS-ET 15.

## Approvals



## JSNY5A/B Technical Data

Manufacturer	ABB AB/Jokab Safety, Sweden
Ordering information	see page 8:30
Color	Black and yellow label
Enclosure/Cover	PA 6 (UL94-VO)
Actuator	Steel
Min. opening radius for actuator on a hatch	150 mm
Ambient operating temperature	-30°C to +80°C
Contacts (actuator key inserted)	2 NC + 1NO (NC are direct opening action)
Mechanical life	1 million switch operations
Max switching frequency	30/min
Fixing	body 2 x M5, actuator 2 x M5
Cable entry	2 x M20 x 1.5
Weight	approx. 0.13 kg
Degree of protection	IP65 IEC 60529 / DIN VDE 0470 T1
Rated insulation voltage	400 V AC
Rated operational current	5A
Utilization category	AC-15/DC-13
Short-circuit protection	Fuse 6A Slow acting, 16A quick acting

CSA	5A 300V AC B300 (same polarity)
B <sub>10d</sub>	JSNY 5A: 2.00×10 <sup>6</sup> JSNY 5B: 2.00×10 <sup>6</sup>
Conformity	2006/42/EG EN ISO 12100 1/2, EN 954-1, EN 60204-1, EN ISO 13849-1, EN 1088, GS-ET 15

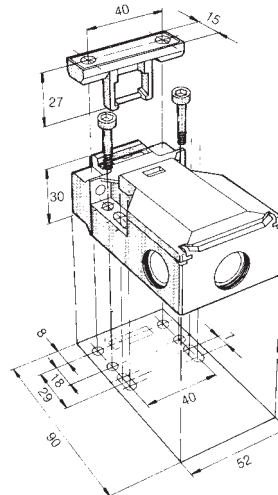

## JSNY5A/B Contact Description

### Overlapping Contact 33-34

The overlapping contact 33-34 enables operational status indication of e.g. incorrect adjustment of switch before the positive forced disconnect NC contacts open.

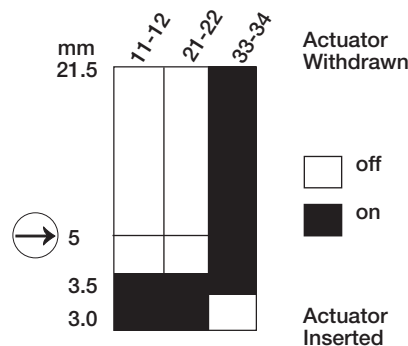
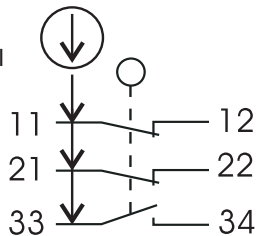

## Accessories and Spare Parts

- Standard actuator
- Flexible key for smaller opening radius
- Cable gland
- Snap-on cover
- Tina 2A with M20 connection for a dynamic loop
- Tina 2B with cable connection
- Tina 3A with M12 and M20 connections for a dynamic loop

## JSNY5A/B Assembly

### Easy Accessibility for Wiring

The snap-on cover is released by a screwdriver and can be opened to an angle of 135° providing easy access to the wiring terminals. Should the snap-on cover not provide adequate security, a retaining screw can be used.

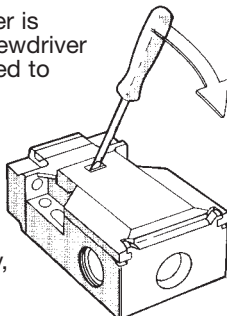

### Protected Contact Block

A transparent cover protects the contact block from external elements during the installation and wiring process.

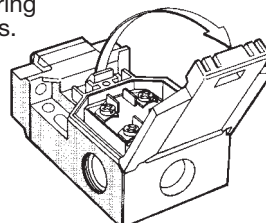

### Prevention of Actuator Dismantling

A cover plate with a one-way snap-fit which seals the mounting screws prevents unauthorized dismantling of the actuator assembly. The cover plate must be mounted to prevent overtravel of the switching mechanism.

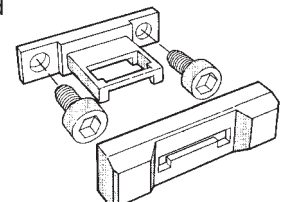

# JSNY7 Magnetic Switch

## Switch Operational Description

The magnetic switch is designed to operate in dirty industrial environments and is certified to the highest level of safety regulation when working together with a suitable ABB Jokab Safety safety relay.

The magnetic switch is small and resistant to both dirt and water, and has no dust collecting cavities making it useful in environments where hygiene is paramount. The small size of the switch makes it easy to position and hide on gates and hatches. The magnetic switch has a long working life since no mechanical contact is made during operation.

## Contacts

The magnetic switch has one closing and one opening contact. Both contacts have to be monitored. The contacts may be monitored by either the RT9 safety relay or other suitable relays in the new RT-series, i.e. RT6, RT9 or the Pluto Safety PLC.

## Safety Level

The JSNY7 is approved to the highest level of safety regulations, PLe according to EN ISO 13849-1 together with a safety relay in the RT-series or Pluto Safety PLC. The magnetic switch is approved and certified by Inspecta.

## Protection from Unauthorized or Incidental Access

To avoid unauthorized operation of the JSNY7 switch it is only possible to actuate the JSNY7R with the coded magnet, JSNY7M. Other magnets, screwdrivers and tools have no affect on the switch contacts.

## Connection Examples

For examples of how our safety switches can solve various safety problems, see "Connection Examples" beginning on page 4:44 of the Safety Relay Section.



## Applications

- Gates and Hatches
- Position Control

## Features

- Small size
- IP 67
- Certified for highest level of safety regulations

## Regulations and Standards

The JSNY7 is designed and approved in accordance with appropriate directives and standards. See technical data.

## Approvals



# JSNY7 Technical Data

Manufacturer	ABB AB/Jokab Safety, Sweden
Ordering information	see page 8:31
Color	Black
Enclosure/Cover	PA 6 (UL94-VO)
Supply voltage max	30 VDC
Switch current max	100 mA
Max switching frequency	1 Hz
Mechanical life	3 x 108 switch operations, depending on load
Operating temperature range	-5°C to +70°C (moveable) -20°C to +70°C (fixed)
Connection	Cable $\varnothing$ 4.5, 4x0.25 mm <sup>2</sup> , 3 meter ; PVC (other lengths upon request)
Switching point	Min. switch-on point 5 mm Max. switch-off point 14 mm
Weight	Coded magnet: 32 g Sensor with 3m cable: 133 g
Protection class	IP67
B <sub>10d</sub>	JSNY 7R-3: 3.00x10 <sup>7</sup> JSNY 7R-6: 3.00x10 <sup>7</sup> JSNY 7R-10: 3.00x10 <sup>7</sup>

Conformity	2006/42/EG EN ISO 12100 1/2, EN 954-1, EN 60204-1, EN ISO 13849-1, EN 1088, GS-ET 15
------------	-----------------------------------------------------------------------------------------------

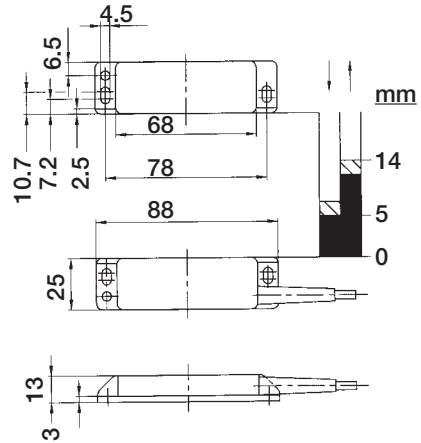

Electrical connection  
Two-channel switching, high safety level.

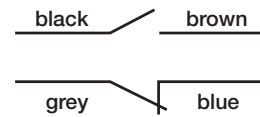

# JSNY7 Contact/Electrical Connection Description

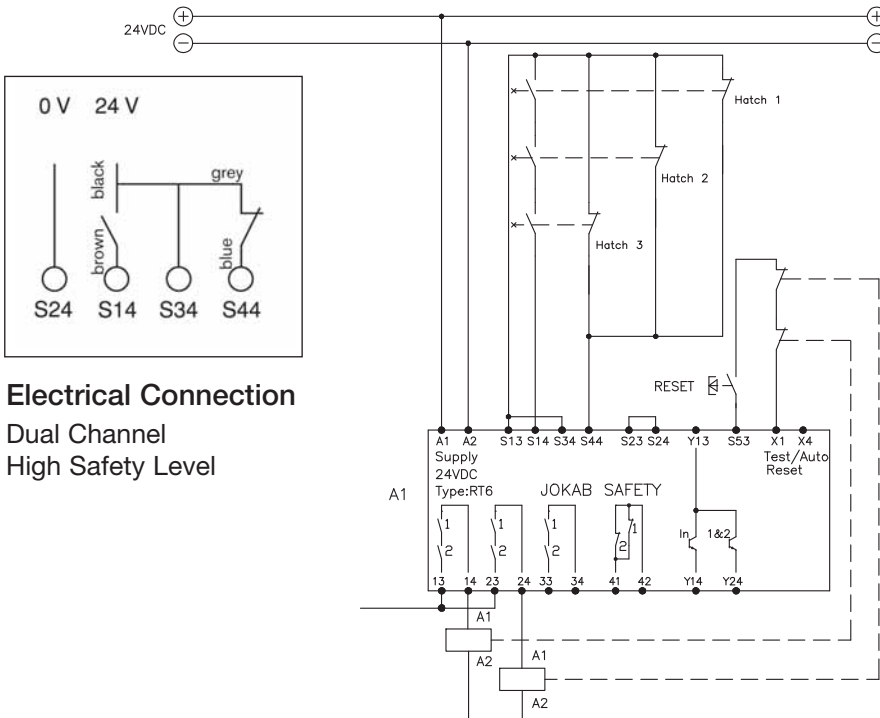

**Electrical Connection**  
Dual Channel  
High Safety Level

**Electrical Connection Example**  
Three JSNY7 connected to RT6 Safety Relay

*Note:*  
Safety components drawn in released position.

*This solution with 3 magnetic switches only complies with category 3 as per EN 954-1/EN ISO 13849-1.*

*To reach highest level of safety only one magnetic switch should be connected to the safety relay.*

# JSNY8 Solenoid Locking Safety Interlock Switch

## Description

The JSNY8 Safety Interlock Switch, in conjunction with the machine control system, enables gates, movable guards, etc. to be locked in their protective positions, thus preventing access to machinery until dangerous operations have ceased.

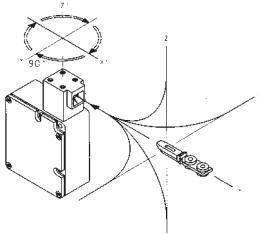

Applications include:

- Processes which cannot be interrupted, such as welding.
- Machinery with a long stopping procedure, such as paper machinery that requires a long braking operation.
- Prevention of unauthorized access to a particular area.

The JSNY8 has 2 + 2 NC positive force disconnection contacts. The first pair closes when the actuator key is pushed into the head. The other pair closes when the locking mechanism is in the locked position.

The head can be set in four positions, thus providing the safety device with four different operating positions. These are selected by twisting the head according to the instructions in the diagram above. The leading edges of the actuator key are reinforced and beveled in order to guide it properly into the hole. The JSNY8 is encased in a robust metal housing (IP67) providing a high level of protection to the internal operating components.

## Two Versions

The JSNY8 is available in two basic versions, either with a spring lock or a magnetic lock. In the spring lock (JSNY8S) version, the locking mechanism moves into the locked position directly when the door is closed and the actuator key is pushed into the lock. The actuator key can only be released and the gate opened by supplying operational voltage to the solenoid (E1-E2). The JSNY8S also has an emergency 'unlocking' facility to enable the actuator key to be released without the energization of the solenoid (E1-E2).

In the magnetic lock (JSNY8M) version, the locking mechanism is only in the locked position when the solenoid (E1-E2) is supplied with operating voltage. Release of the actuator key is only possible when the operating voltage is removed from the solenoid (E1-E2).

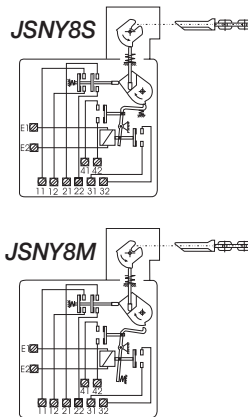

## Safety Level

The JSNY8 has double forced disconnection contacts to the actuator key and the locking mechanism. The actuator key has a triple coding design. To achieve maximum safety level in the connection to the machine's control system, it is recommended that the JSNY8 is monitored by an appropriate ABB Jokab Safety safety relay, Pluto Safety PLC or Vital. To obtain the same level of safety as Knox, two switches per gate are required.



## Applications

- Gates and Hatches

## Features

- Robust design
- Universal installation
- 2 NC + 2 NC outputs
- 1000 N locking force

## Tamper-Proof

The JSNY8 Safety Interlock Switch is tamper-proof. The safety device cannot be manipulated by screwdrivers, magnets or other tools.

## Connection Examples

For examples of how our safety switches can solve various safety problems, see "Connection Examples" beginning on page 4:44 of the Safety Relay Section.

## Regulations and Standards

The JSNY8 is designed and approved in accordance with appropriate standards. See technical data.

## Approvals



# JSNY8S/M Technical Data

Manufacturer	ABB AB/Jokab Safety, Sweden
Ordering information	see pages 8:31-8:32
Color	Black
Enclosure	Metal housing
Actuator key	Steel and plastic (PA6)
Min. operating radius for hatch	400 mm (smaller radius on request)
Actuator holding force	1000 N
Working temperature	-30°C to +60°C
Contacts actuator key inserted locking mechanism, locked position	2 NC 2 NC
Mechanical service life	1 million switch operations
Installation fixings	3 x M5
Cable entry	2x M20 x 1.5
Weight	550 g
Enclosure class	IP67
Operating voltage	24V DC, 230 V AC
Rated insulation voltage	250V
Rated operating current	10A

Utilization category	AC 12 250V/10A AC 15 230V/4A
Short-circuit protection	Fuse 10A slow-acting, 16A quick-acting
Power consumption	5.2 W
B <sub>10d</sub>	JSNY 8M 24 VDC: 2.00×10 <sup>6</sup> JSNY 8M 230 VAC: 2.00×10 <sup>6</sup> JSNY 8S 24 VDC: 2.00×10 <sup>6</sup> JSNY 8S 230 VAC: 2.00×10 <sup>6</sup>
Conformity	2006/42/EG EN ISO 12100 1/2, EN 954-1, EN 60204-1, EN ISO 13849-1, EN 1088, GS-ET 19, EN 60947-5-1

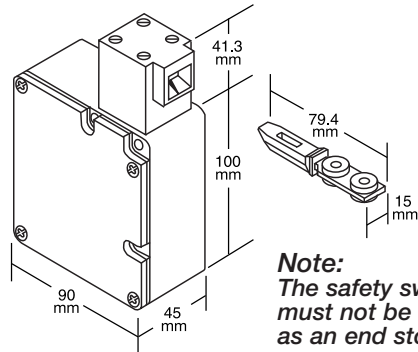

**Note:**  
The safety switch must not be used as an end stop!

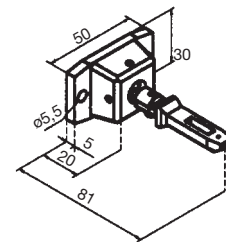
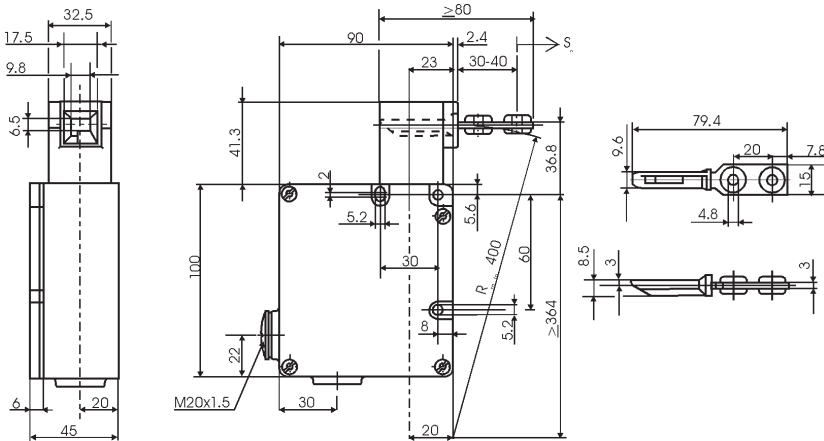

**JSNY8/9N2**  
Rmin: 150 mm  
Flexible actuator.

## JSNY8S/M Contact Description

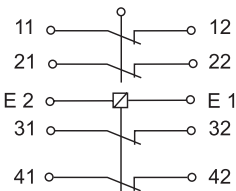

### JSNY8S

Key actuator inserted  
Normally locked  
(E1-E2 unpowered)

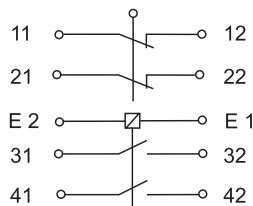

### JSNY8M

Key actuator inserted  
Normally unlocked  
(E1-E2 unpowered)

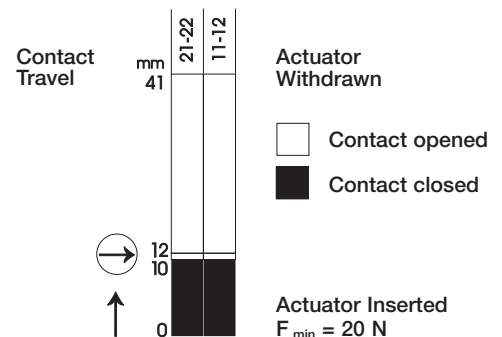

# JSNY9 Solenoid Locking Safety Interlock Switch

## Description

The JSNY9 is used for locking a gate/hatch, to prevent access to machinery, until hazardous operations have ceased.

Applications include:

- Processes which cannot be interrupted, e.g. welding.
- Machinery with a long stopping time, e.g. paper machinery which requires a long braking operation.
- Prevention of unauthorized access to a particular area.

The JSNY9 is equipped with a 2 x (1NO + 1 NC) contact configuration, the first pair of contacts changeover when the key is inserted. The second pair of contacts changeover when the locking mechanism is in the locked position.

The JSNY9 switch is encased in a robust plastic housing and can be mounted either horizontally or vertically. The advanced design of the head provides eight possible key insertion options. This is achieved by mounting the head either vertically or horizontally on the base unit, as shown in the diagram. The location for the actuator key is reinforced and beveled to ensure a smooth operation.

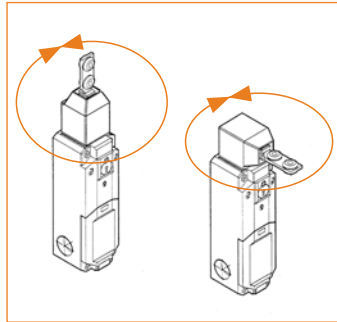

*The control unit offers eight operating positions that provide the actuator with eight different input options.*

## Two Versions

The JSNY9 switch is available in two basic versions, either with a spring lock or an electromagnetic locking mechanism.

The JSNY9S (spring lock) switch operates immediately when the gate/hatch is closed, i.e. when the key actuator is inserted into the locking mechanism. The gate/hatch can be opened and the actuator key released only by supplying the operational voltage to the solenoid connections (E1 E2). The JSNY9S also has a manual emergency "unlocking" facility to enable authorized release of the actuator key.

In the JSNY9M (magnetic lock) version, the mechanism is only locked when the gate/hatch is closed i.e. the actuator key inserted and the solenoid (E1 E2) supplied with the operating voltage. The gate/hatch can only be opened when this operating voltage is removed.

## Safety Level

In order to achieve a high safety level, the JSNY9 switch is equipped with dual sets of contacts operated with a coded actuator key. In order to meet the required installation safety level it is recommended that the JSNY9 safety switch is monitored by an appropriate ABB Jokab Safety safety relay, Pluto Safety PLC or Vital. To obtain the same level of safety as Knox, two switches per gate are required.



## Applications

- Gates and Hatches

## Features

- Compact and robust
- Universal installation
- 2 x (1 NO + 1 NC)
- Actuator holding force 1500 N
- Eight head configurations

## Protection from Unauthorized or Incidental Access

The JSNY9 is designed to protect against unauthorized access; screwdrivers, magnets or similar tools cannot manipulate the safety switch.

## Connection Examples

For examples of how our safety switches can solve various safety problems, see "Connection Examples" beginning on page 4:44 of the Safety Relay Section.

## Regulations and Standards

The JSNY9 is designed and approved in accordance with appropriate standards. See technical data.

## Approvals





## JSNY9S/M Technical Data

Manufacturer	ABB AB/Jokab Safety, Sweden
Ordering information	see page 8:32
Color	Black
Enclosure/Cover	Polyamid PA6
Actuator	Steel and plastic (PA6)
Min. key operating radius	400 mm
Actuator holding force	1500 N
Operating temperature	- 25° C to + 70° C
Contacts	
Actuator in	1 NO + 1 NC
Locking mechanism in locked position	1 NO + 1 NC (NC are direct opening action)
Mechanical life	1 million switch operations
Installation fixing	4 x M5
Cable entry	3 x M20 x 1.5
Weight	approx. 300 g
Enclosure class	IP67
Operating voltage	24 V AC/DC
Isolation voltage	250 V
Thermal current	2.5 A
Utilization category	AC 15 230V / 4A

Short-circuit protection	Fuse 6 A slow acting
Power consumption	1.1 VA (56 VA during 0.2s)
B <sub>10d</sub>	JSNY 9M: 2.00E+06 JSNY 9S: 2.00E+06
Conformity	2006/42/EG EN ISO 12100 1/2, EN 954-1, EN 60204-1, EN ISO 13849-1, EN 1088, GS-ET 19, EN 60947-5-1

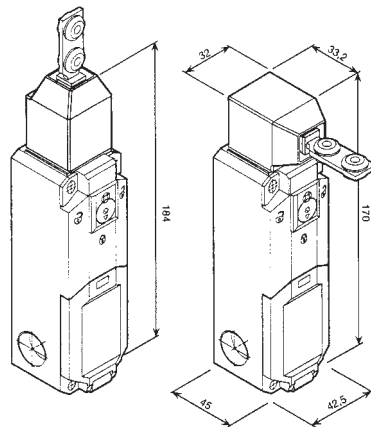

**Note:**  
The safety switch must not be used as an end stop!

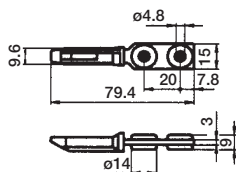

JSNY8/9N1

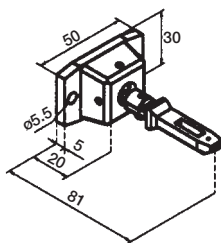

JSNY8/9N2  
Rmin: 150 mm

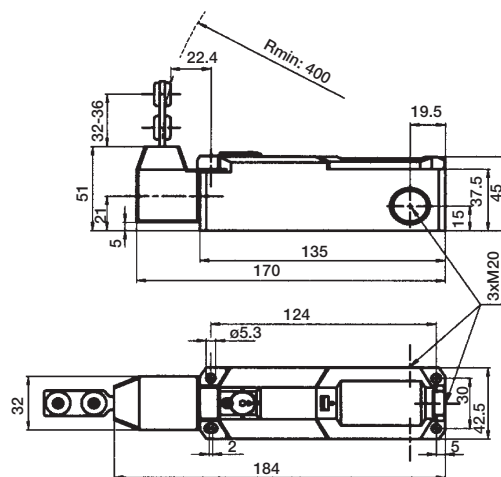

## JSNY9S/M Contact Description

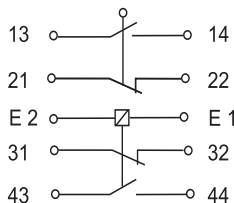

### JSNY9S

Actuator inserted  
Locked position  
(E1-E2 unpowered)

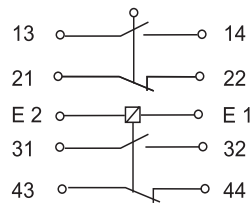

### JSNY9M

Actuator inserted  
Unlocked position  
(E1-E2 unpowered)

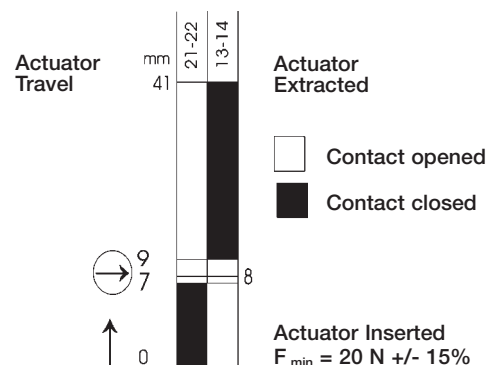

# Magne 1/2 Magnetic Process Lock with Indication

The Magne 1 is a magnetic lock which has been adapted for use in industrial applications and other harsh environments. It can electrically lock and hold a door closed with up to 1500 Newtons of force and when power is turned off no magnetic material will stick on the magnet surface.

Magne 1 can be used together with Eden door position sensors providing protection from dangerous machine movements.

Magne 2 already has an Eden sensor built in. Use of M12 connectors makes it easy to connect several Magne units and Eden sensors in series enabling control and monitoring by either a Pluto Safety PLC, a Vital Safety Module or a Urax block (for use in AS-i applications). Via the connection cable it is also possible to obtain an indication signal informing if the Magne unit is locked or not.



## Applications

- Electrical locking of doors and hatches to production applications that are sensitive to unintentional/unnecessary interruptions
- For safety supervision the Magne 2 has an integrated Eden

## Features

- Robust construction
- No moving parts
- Strong magnetic holding force of 1500N
- Can stand and operate in harsh environments
- Locked/unlocked indication
- Possible to connect in series with Eden sensors
- No current peaks on activation
- Magne 2 in combination with a handle profile provides a complete door solution
- Magne 1/2 B versions come with a built-in 30mm magnet
- Magne 1/2 A/B X versions interface with the Urax block for AS-i applications

## Accessories

- Mounting kit for conventional door, with fitting and screws for assembly on ABB Jokab Safety Quick-Guard fencing system (5-15 mm door gap)
- Plastic handle
- Handle profile for mounting on a hinged door with Jokab Safety Quick-Guard fencing system (5-15 door gap)



*Magne is easy to assemble, adjust and dismantle in and out of the T-slot of the Quick-Guard fencing system.*

## Magne Models and Accessories



Handle profile that hides Magne completely when the door is closed.



Magne 1A with installation kit (JSM D21B) and handle (incl. screw) fitted on profile.



Magne 2A with installation kit (JSM D21B) (JSM D23) for sliding door fitted on profile.

<b>Magne 1A</b>	2TLJ042022R0000	Process lock, incl. anchor plate
<b>Magne 2A</b>	2TLJ042022R1000	Process lock with built-in Eden, incl. anchor plate
<b>Magne 1B</b>	2TLJ042022R0100	Process lock incl. anchor plate with built-in permanent magnet (30 N)
<b>Magne 2B</b>	2TLJ042022R1200	Process lock incl. anchor plate with built-in Eden and built-in permanent magnet (30 N)
<b>Magne 2Ax</b>	2TLJ042022R1300	Process lock with built-in Eden and 5-pin M12 connector for Urax, incl. anchor plate
<b>Magne 2Bx</b>	2TLJ042022R1400	Process lock with built-in Eden and 5-pin M12 connector for Urax, incl. anchor plate with built-in permanent magnet (30 N)
<b>Accessories</b>		
<b>JSM D21B</b>	2TLJ042023R0500	Assembly kit for anchor plate
<b>JSM D2AGS</b>	2TLJ042023R0100	Handle profile for Magne
<b>JSM D23</b>	2TLJ042023R0200	Fixture for sliding door
<b>JSM D24</b>	2TLJ042023R0300	Assembly kit for Eva
	2TLJ042023R0400	Anchor plate with permanent magnet
	2TLJ042023R1000	Handle for JSM D21B



Magne 2A with installation kit (JSM D21B, JSM D24) and handle (incl. screw) fitted on profile.

## Magne Technical Data

<b>Manufacturer</b>	ABB AB/Jokab Safety, Sweden
<b>Ordering information</b>	see page 8:33
<b>Safety level</b> IEC/EN 61508-1...7 EN 62061 EN ISO 13849-1	SIL3 SIL3 Cat. 4/PL e
<b>PFH<sub>d</sub></b>	4.50×10 <sup>-9</sup>
<b>Power supply</b> Magnet Eden	24 VDC + 15% -20% 17–27 VDC, ripple max 10%
<b>Power consumption</b> Magnet Eden	7 W (300 mA at 24VDC) 45–55 mA (see data for Eden)
<b>Operating temp. range</b>	-20°C to +50°C
<b>Protection class</b>	IP67
<b>Weight</b> Magne 1 Magne 2 Anchor	610 g 700 g 290 g
<b>Material</b> Anchor plate and magnet Housing	steel aluminum
<b>Holding force</b> 24 VDC 0 VDC 0 VDC	Min 1500 N 0 N (Magne 1A/2A) 30 N (Magne 1B/2B)
<b>Contacts</b>	Reed sensor (not safe)
<b>Switch current max</b>	100 mA
<b>Mechanical life</b>	>10 <sup>7</sup> switch operations
<b>Connector</b>	M12 5-pole male connector (Magne 1A, 1B, 2Ax, 2Bx) M12 8-pole male connector (Magne 2A, 2B)

<b>Connections</b>	<p>Magne 1A/B: (1) Brown: Locking, +24 VDC (2) White: Sensor supply (3) Blue: 0 VDC (4) Black: NO-contact (5) Grey: NC-contact</p> <p>Magne 2A/B: (1) White: Dynamic signal input (2) Brown: +24V DC (3) Green: Locking, +24V DC (4) Yellow: Locking, 0V DC (5) Grey: Info closed (max 10 mA) (6) Pink: Dynamic signal output (7) Blue: 0V DC (8) Red: Info locked (max 100 mA)</p> <p>Magne 2Ax/Bx: (1) Brown: +24 VDC (2) White: Dynamic signal input (3) Blue: 0 VDC (4) Black: Dynamic signal output (5) Grey: Locking</p>
<b>Conformity</b>	2006/42/EG EN ISO 12100-1/2:2003, EN ISO 13849-1:2008, EN 62061:2005, EN 1088
<b>Certifications</b>	TÜV Nord 

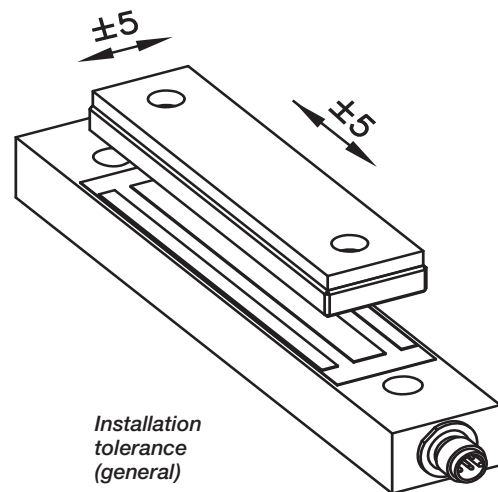

## Magne Dimensions

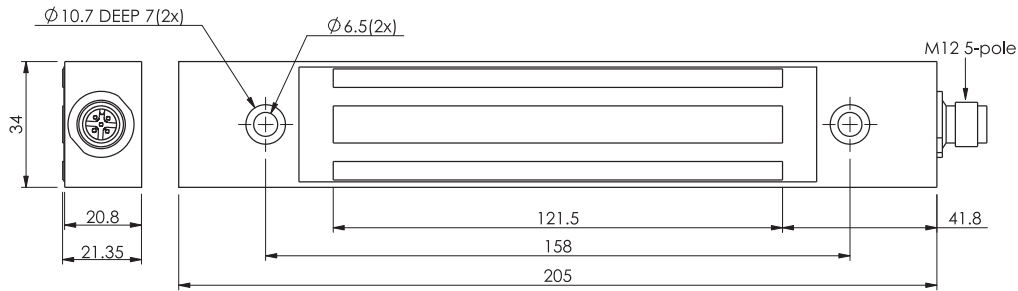

**Dimensions Magne 1A/B**

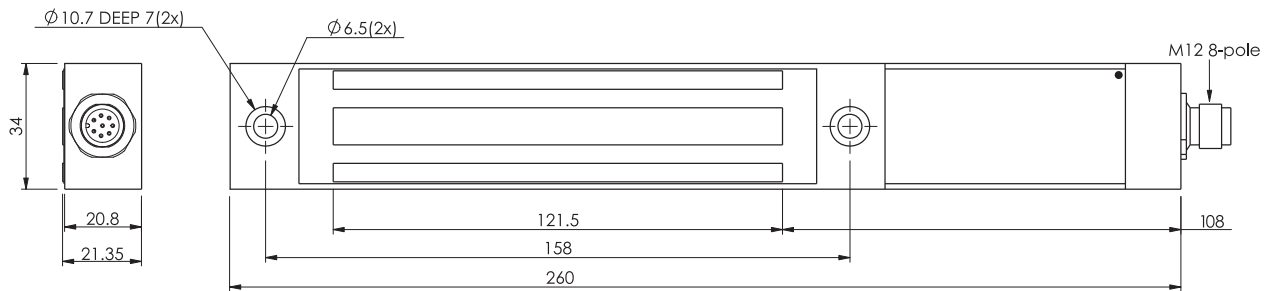

**Dimensions Magne 2A/B**

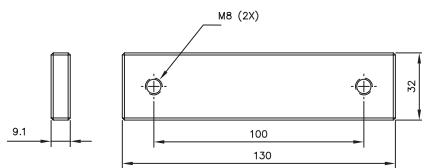

**Dimensions Anchor plate  
(without permanent magnet)**

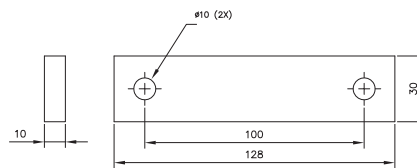

**Dimensions - cell rubber**

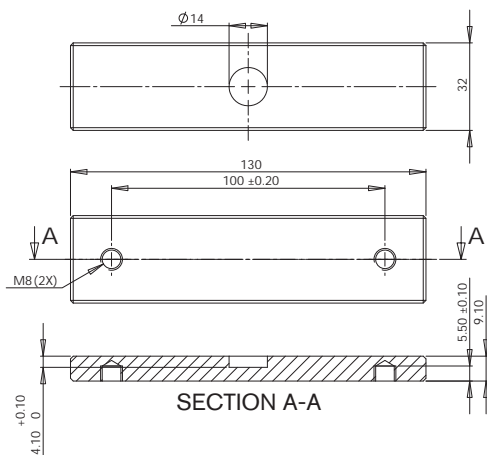

**Dimensions Anchor plate  
(with permanent magnet)**



## Connection Example Magne 1A in series

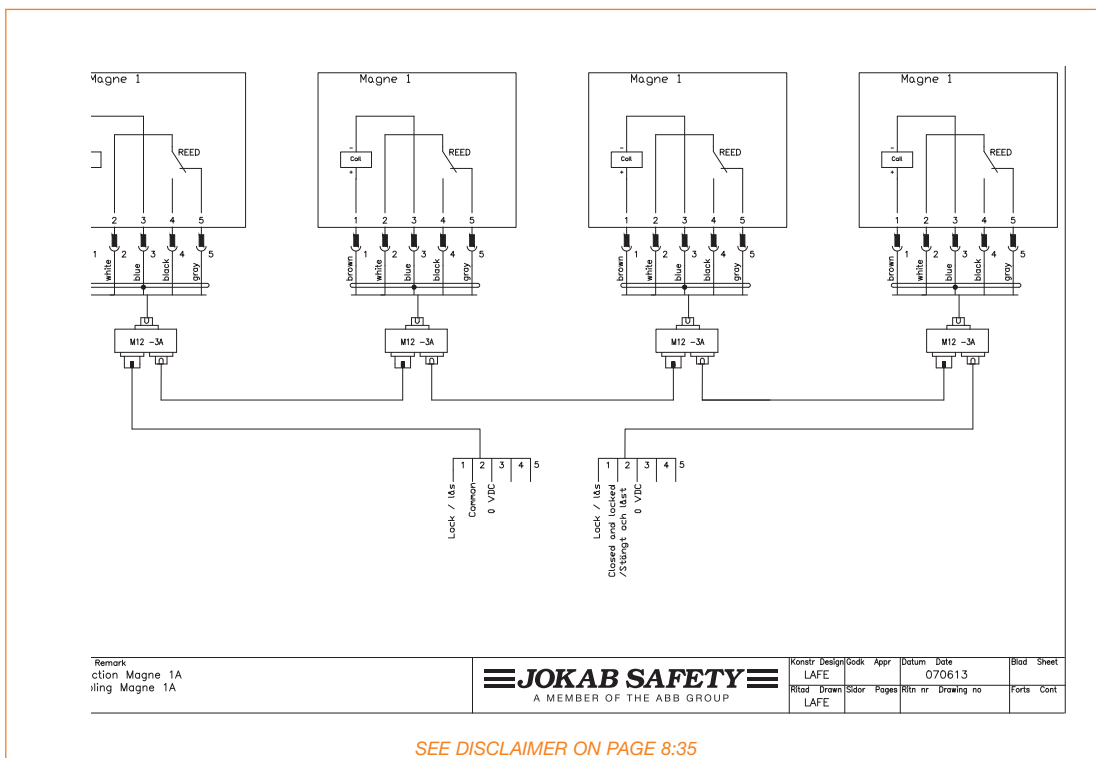

## Connection Example Magne 2A in series

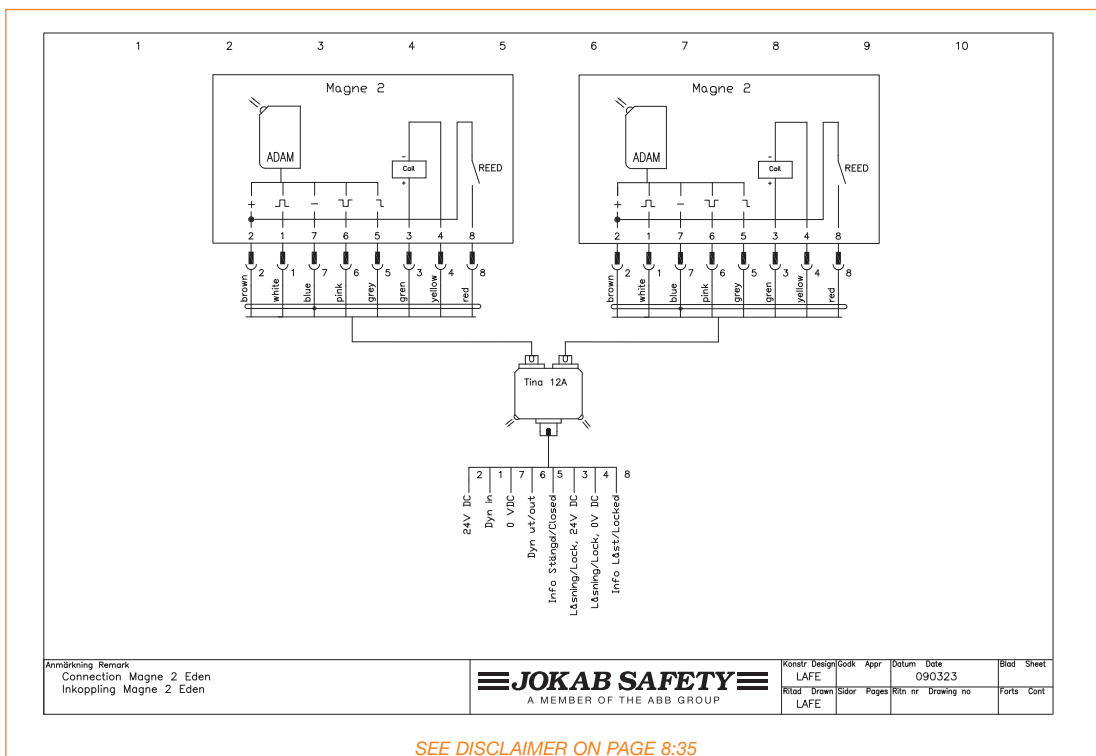

# Knox Safety Lock for Secure Locking

Knox is a double lock that complies with the highest safety level — two lock cylinders with monitored positions — that can be used both as a safety and process lock. The locking function is electronically controlled and is bi-stable, i.e. it retains its position (locked/unlocked) in the event of a power failure.

The handles operate as they would on a normal door — except that the exterior handle also has a reset function and there is an interior handle that can be used for emergency opening.

Its design and durability mean that it is ideal for harsh environments, as the sensors in the lock are non-contact and the lock is manufactured of stainless steel.



*Knox Safety Lock Open*



*Knox Safety Lock Emergency Opened*



*Knox Safety Lock Reset, Openable*



*Knox Safety Lock Operational Mode Locked and Reset (Emergency Opening Only)*

## Applications

- Locking doors to cells/lines with long stop times
- Application where you need a robust lock

## Features

- Double locking function as specified in PL e/Category 4 (EN ISO 13849-1)
- Withstands harsh environments
- Status information with LEDs on lock housing and at cable connection
- Controlled to locked and unlocked positions—remain locked/unlocked in the event of power failure
- Electronic connection only on the door frame
- Optional manual unlock from the outside available



## Approvals













Intertek

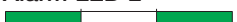

# Knox Technical Data

<b>Manufacturer</b>	ABB AB/Jokab Safety, Sweden	
<b>Ordering information</b>	see page 8:34-8:35	
<b>Safety level</b> EN ISO 13849-1	Cat. 4/PL e	
<b>PFH<sub>d</sub></b>	4.50×10 <sup>-9</sup>	
<b>Lock function</b>	S/M - unlocked and locked with voltage	
<b>Operating voltage</b>	24 VDC +/- 15%	
<b>Power consumption</b>	70 mA (in locked position)	
Electronics	135 mA (when locking/unlocking)	
Lock/lock inverse	150 mA	
Total max	Max. 10 mA	
Information output		
<b>Insulation class</b>	IP65	
<b>Holding strength</b>		
Unlocked	5000 N (10,000 N ultimate breaking strength)	
Locked	5000 N (10,000 N ultimate breaking strength)	
<b>Connection</b>	Male plug M12, 8-pole	
<b>Connections Knox 2A</b>		
Function	8-pole	Color
Dynamic input signal	1	(White)
+24 VDC	2	(Brown)
Lock	3	(Green)
Lock inverse	4	(Yellow)
Information Locked	5	(Grey)
Dynamic output signal	6	(Pink)
0 VDC	7	(Blue)
Information reset	8	(Red)
<b>Connections Knox 2X</b>		
Function	5-pole	Color
+24 VDC	1	(Brown)
Dynamic signal input	2	(White)
0 VDC	3	(Blue)
Dynamic signal output	4	(Black)
Lock	5	(Grey)
<b>Warning</b>		
Knox locks mechanically. Forcing the lock may damage Knox permanently		
When mounting Knox on door with mesh the accessory PC plate for Knox is recommended. This is to prevent emergency opening from the outside		
When mounting Knox on a low door it is recommended to replace emergency release handle with the accessory PC plate for Knox to prevent opening from the outside by reaching over		
<b>Conformity</b>	2006/42/EG EN ISO 12100-1/2:2003, EN ISO 13849-1:2008, EN 62061:2005, EN 1088	
<b>Approvals</b>	 	

<b>LED indicator</b>	 =Red  =Green  =Pause	Function
<b>LED 1</b>	  	Locked (and reset) Locked, no dynamic signal in Unlocked
<b>LED 2</b>	 	Reset Not reset
<b>Alarm LED 2</b>	 	Dirt indicator reset sensor Reset Not reset

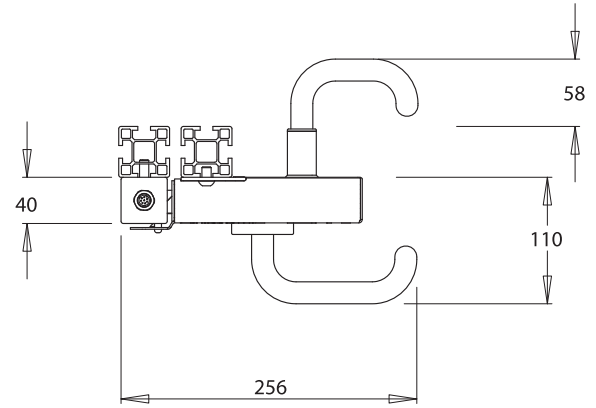
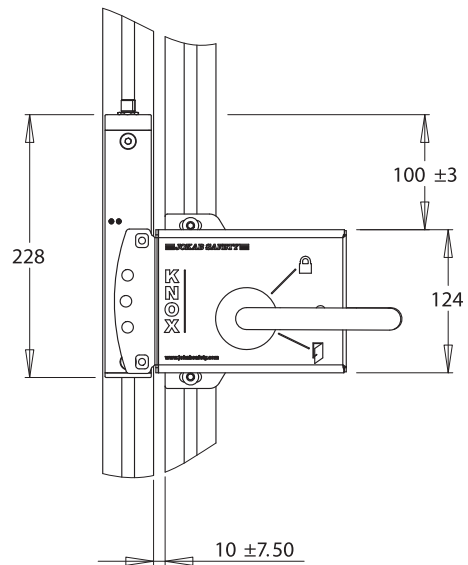

# Connection Example

## Knox

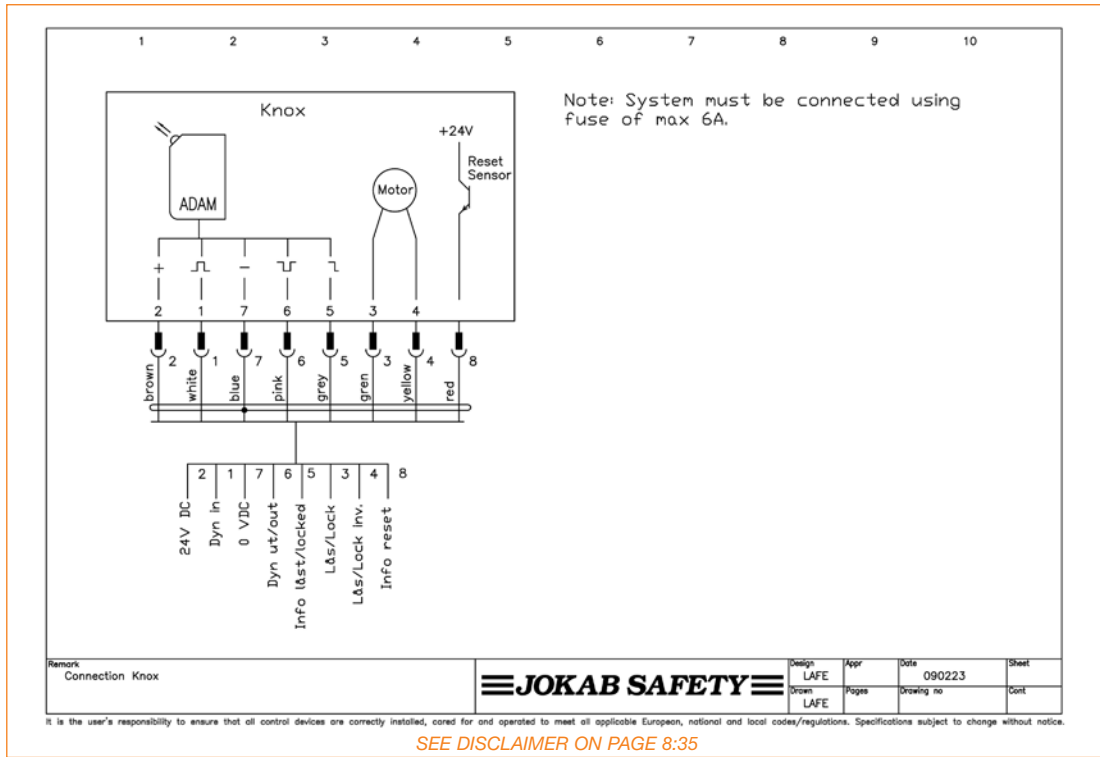

# Connection Example

## Knox and Pluto

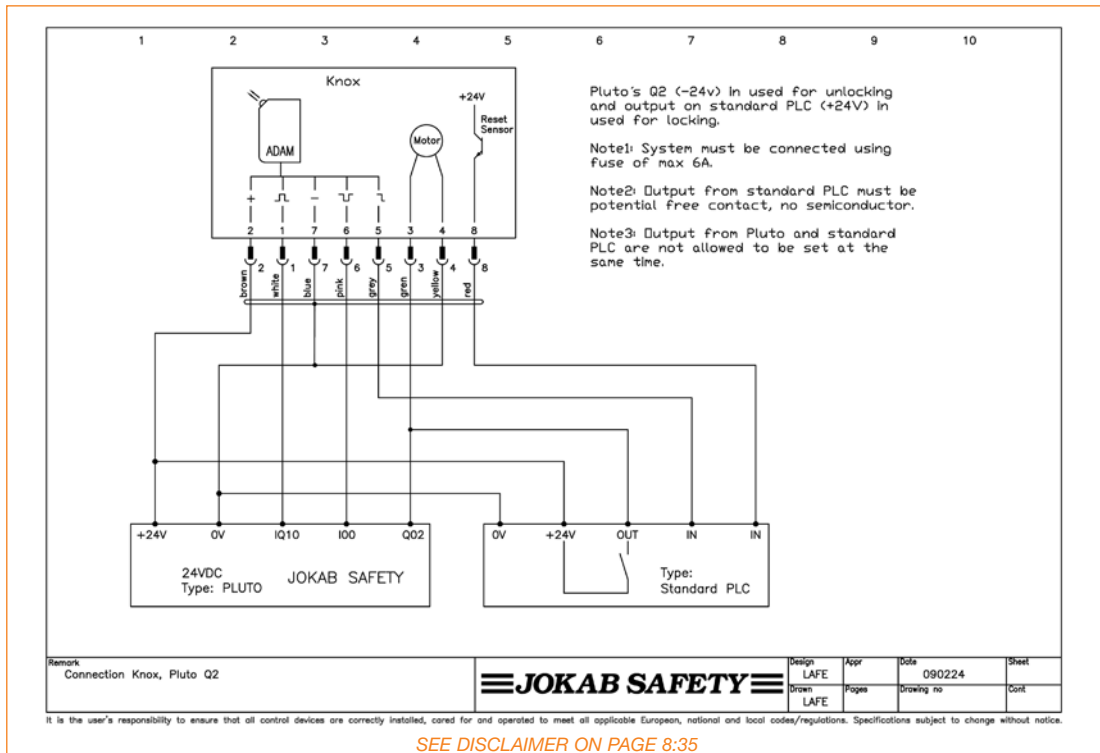



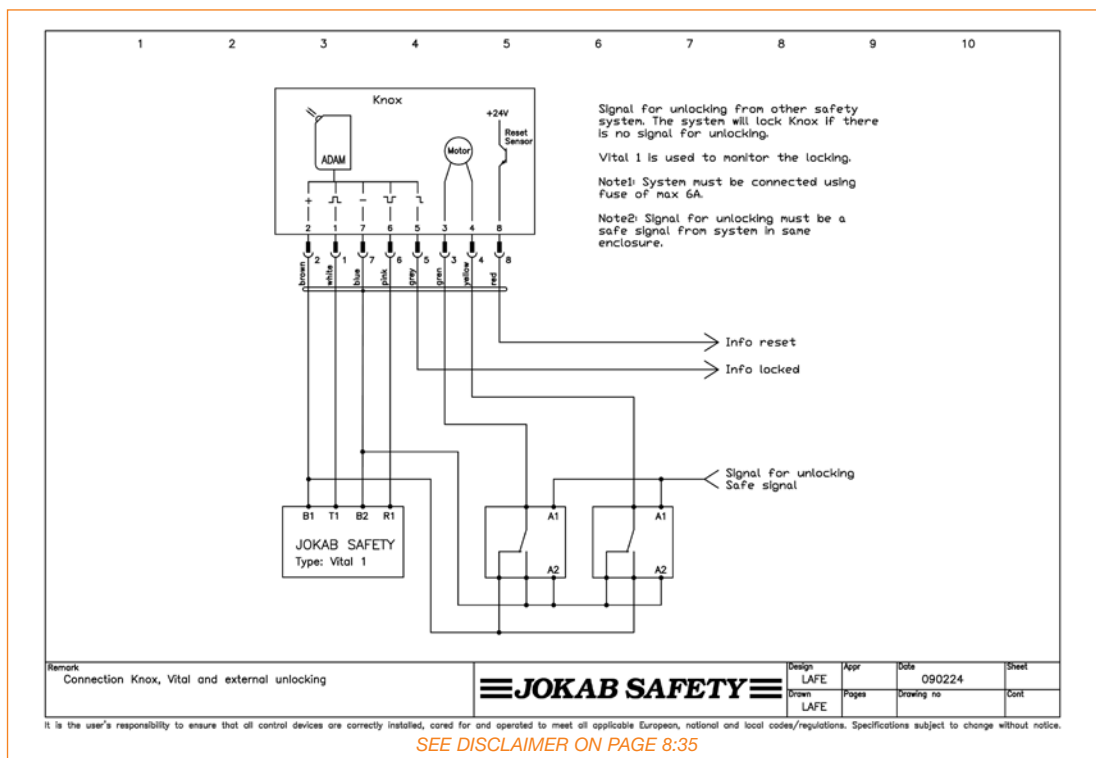

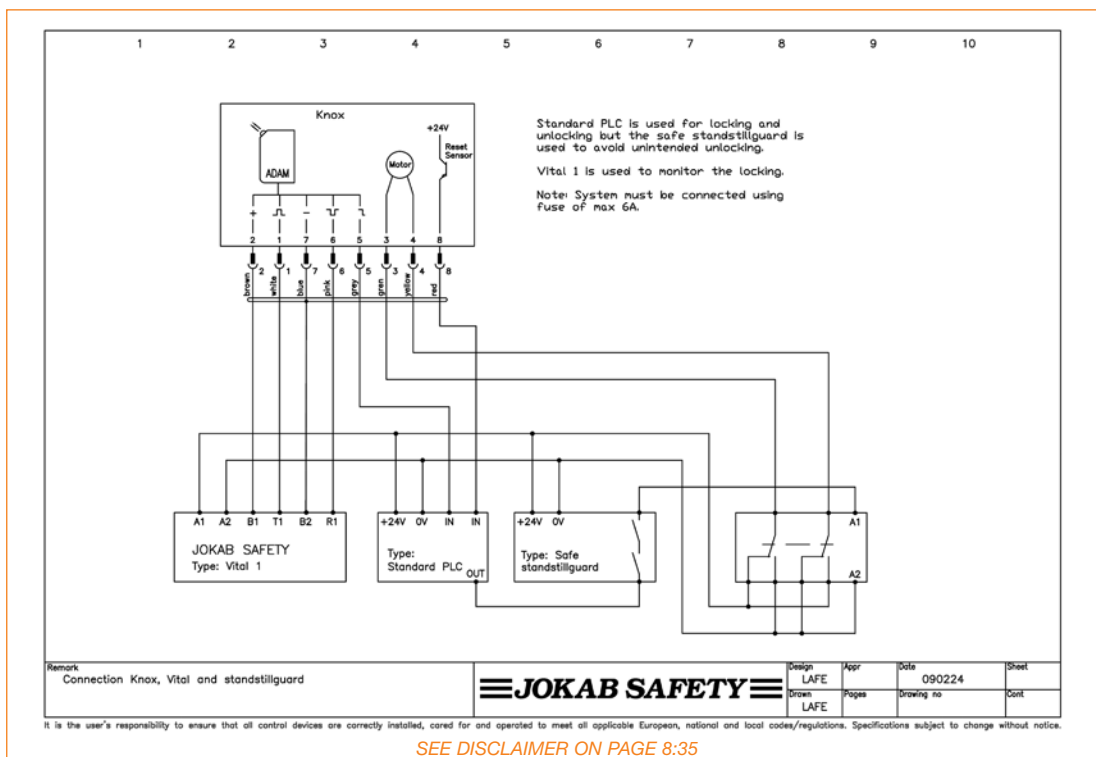

## Connection Example Knox with Vital and External Unlocking











## Connection Example Knox with Downtime Monitor

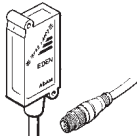

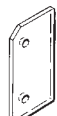



## Component List - Sensors and Switches

Designation	Ordering Information	Description
Eva	 2TLJ020046R0000	Electronic actuator for Adam switches, IP67 protection degree, polyamid housing. Includes 4 pieces of DA2 mounting washers.
Eva E	 2TLJ020046R0600	Electronic actuator encapsulated for Adam switches, IP69K protection degree, polyamid housing.
Adam M12	 2TLJ020051R0000	Non-contact electronic safety sensor with 5 pole M12 male quick disconnect, multi-function status indicator LED, integrated information output 24VDC - 10mA, IP67 protection degree, versatile mounting with 360 degree detection, sensing distance of 0-15mm +/- 2mm with Eva, polyamid housing. Requires Vital 1 controller or Pluto Safety PLC to function. Maximum of 30 Eden sensors connected to one Vital controller possible while maintaining category 4 level of safety (10 per Pluto input). 4 pieces DA1 distance protection plate and 4 pieces DA2 mounting washers included.
Adam 3m	 2TLJ020051R0200	Non-contact electronic safety sensor with 3 meter molded PVC cable, multi-function status indicator LED, integrated information output 24VDC - 10mA, IP67 protection degree, versatile mounting with 360 degree detection, sensing distance of 0-15mm +/- 2mm with Eva, polyamid housing. Requires Vital 1 controller or Pluto Safety PLC to function. Maximum of 30 Eden sensors connected to one Vital controller possible while maintaining category 4 level of safety (10 per Pluto input). 4 pieces DA1 distance protection plate and 4 pieces DA2 mounting washers included. M12 male connection at end of cable.
Adam 10m	 2TLJ020051R0400	Non-contact electronic safety sensor with 10 meter molded PVC cable, multi-function status indicator LED, integrated information output 24VDC - 10mA, IP67 protection degree, versatile mounting with 360 degree detection, sensing distance of 0-15mm +/- 2mm with Eva, polyamid housing. Requires Vital 1 controller or Pluto Safety PLC to function. Maximum of 30 Eden sensors connected to one Vital controller possible while maintaining category 4 level of safety (10 per Pluto input). 4 pieces DA1 distance protection plate and 4 pieces DA2 mounting washers included. M12 male connection at end of cable.
Adam 20m	 2TLJ020051R0500	Non-contact electronic safety sensor with 20 meter molded PVC cable, multi-function status indicator LED, integrated information output 24VDC - 10mA, IP67 protection degree, versatile mounting with 360 degree detection, sensing distance of 0-15mm +/- 2mm with Eva, polyamid housing. Requires Vital 1 controller or Pluto Safety PLC to function. Maximum of 30 Eden sensors connected to one Vital controller possible while maintaining category 4 level of safety (10 per Pluto input). 4 pieces DA1 distance protection plate and 4 pieces DA2 mounting washers included. M12 male connection at end of cable.

## Component List - Sensors and Switches

Designation		Ordering Information	Description
Adam E 10m		2TLJ020051R0600	Non-contact electronic safety sensor encapsulated with 10 meter molded PVC cable, multi-function status indicator LED, integrated information output 24VDC - 10mA, IP69K protection degree, versatile mounting with 360 degree detection, sensing distance of 0-12mm +/- 2mm with EvaE, polyurethane housing for harsh environments. Requires Vital 1 controller or Pluto Safety PLC to function. Maximum of 30 Eden sensors connected to one Vital controller possible while maintaining category 4 level of safety (10 per Pluto input). M12 male connection at end of cable.
Adam E 0.5m M12		2TLJ020051R0700	Non-contact electronic safety sensor encapsulated with 0.5 meter molded PVC cable and 5 pole M12 male quick disconnect, multi-function status indicator LED, integrated information output 24VDC - 10mA, IP69K protection degree (IP67 at connector), versatile mounting with 360 degree detection, sensing distance of 0-12mm +/- 2mm with EvaE, polyurethane housing for harsh environments. Requires Vital 1 controller or Pluto Safety PLC to function. Maximum of 30 Eden sensors connected to one Vital controller possible while maintaining category 4 level of safety (10 per Pluto input).
Adam E 20m		2TLJ020051R0800	Non-contact electronic safety sensor encapsulated with 20 meter molded PVC cable, multi-function status indicator LED, integrated information output 24VDC - 10mA, IP69K protection degree, versatile mounting with 360 degree detection, sensing distance of 0-12mm +/- 2mm with EvaE, polyurethane housing for harsh environments. Requires Vital 1 controller or Pluto Safety PLC to function. Maximum of 30 Eden sensors connected to one Vital controller possible while maintaining category 4 level of safety (10 per Pluto input).
DA 1		2TLJ020053R0000	Distance protective plate for Adam M12. Polycarbonate with 2.5mm thickness. Suitable for Adam 3m/10m/20m if necessary.
DA 2		2TLJ020053R0100	Mounting spacer 4.5 x 8 x 4 mm, polyamid for use with Adam and Eva units.
		2TLJ020053R1000	M4 mounting screw (length 18 mm) for recessed mounting of Adam and Eva.
		2TLJ020053R2000	M4 mounting screw (length 16 mm) for projecting mounting of Adam and Eva.
		2TLJ020053R3000	M4 mounting screw (length 25 mm) for projecting mounting of Adam E and Eva E.
		2TLJ020053R3200	M4 nylon mounting screw (length 25 mm) for recessed or projecting mounting of Adam and Eva ( Adam E and Eva E).

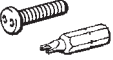

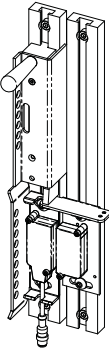

## Component List - Sensors and Switches

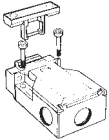
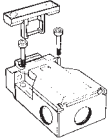
Designation	Ordering Information	Description
DA 2 (continued) 	2TLJ020053R4200	Safety screw (SM4 x 20) for mounting Adam and Eva.
	2TLJ020053R4300	Safety screw (SM4 x 25) for mounting of Adam E and Eva E.
	2TLJ020053R5000	Safety screwdriver bit SBITS
	2TLJ020053R6200	4 Safety screws (SM4 x 20mm) + 1 screwdriver bit
	2TLJ020053R6300	4 Safety screws (SM4 x 25mm) + 1 screwdriver bit
JSNA-SafeSlide™ 	2TLA850003R0800	Eden lockout assembly for safe lockout at the door. Provisions for up to 6 locks that fastens the metal plate between the Eden pair. Adjustable for either right side or left side opening doors.
JSNA-SafeSlide™ Sliding Doors	2TLA850103R0500	Eden lockout assembly for safe lockout at the door. Provisions for up to 6 locks that fastens the metal plate between the Eden pair. Designed for Quickguard sliding doors.

## Component List - Mechanical Switches

Designation	Ordering Information	Description
JSNY5A 	2TLJ020022R0000	Safety interlock switch with 2 NC positive opening & 1 NO contacts, 6A rated operational current, 10N actuator retention force, IP65, plastic body, two M20 conduit entries, comes with steel actuator.
JSNY5B 	2TLJ020022R0100	Safety interlock switch with 2 NC positive opening & 1 NO contacts, 6A rated operational current, 30N actuator retention force, IP65, plastic body, two M20 conduit entries, comes with steel actuator.

## Component List - Mechanical Switches

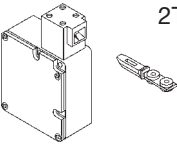
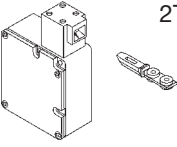
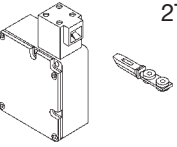
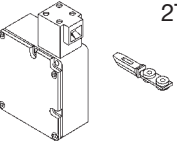





Designation		Ordering Information	Description
JSNY7R-3		2TLJ020023R0000	Magnetic safety switch with 1 NO & 1 NC contacts, 100mA switched current maximum, IP67, plastic body, 3 meters of molded cable.
JSNY7R-6		2TLJ020023R0100	Magnetic safety switch with 1 NO & 1 NC contacts, 100mA switched current maximum, IP67, plastic body, 6 meters of molded cable.
JSNY7R-10		2TLJ020023R0200	Magnetic safety switch with 1 NO & 1 NC contacts, 100mA switched current maximum, IP67, plastic body, 10 meters of molded cable.
JSNY7M		2TLJ020024R0000	Coded magnet for JSNY7 IP67, plastic body.
JSNY8M		2TLJ020030R0000	Safety interlock switch with power to lock 24VDC (5.2W) solenoid, 2 NC positive opening contacts from actuator and 2NC contacts from solenoid, 10A rated operating current, 1000N locking force, IP67, metal body, two M20 conduit entries, comes with metal actuator.
JSNY8S		2TLJ020030R0100	Safety interlock switch with power to unlock 24VDC (5.2W) solenoid, 2 NC positive opening contacts from actuator and 2NC contacts from solenoid, 10A rated operating current, 1000N locking force, IP67, metal body, two M20 conduit entries, comes with metal actuator.
JSNY8MN2		2TLJ020030R0200	Safety interlock switch with power to lock 24 VDC (5.2W) solenoid, 2 NC positive opening contacts from actuator and 2NC contacts from solenoid, 10A rated operating current, 1000 N locking force, IP67, metal body, two M20 conduit entries, comes with flexible actuator.
JSNY8SN2		2TLJ020030R0300	Safety interlock switch with power to unlock 24 VDC (5.2W) solenoid, 2 NC positive opening contacts from actuator and 2NC contacts from solenoid, 10A rated operating current, 1000 N locking force, IP67, metal body, two M20 conduit entries, comes with flexible actuator.

## Component List - Mechanical Switches

Designation	Ordering Information	Description
JSNYN1	2TLJ020032R0000	Steel actuator for JSNY4/5 safety interlock switches.
JSNYN2	2TLJ020032R0100	Steel actuator for JSNY4/5 safety interlock switches for horizontal operation.
JSNYN5	2TLJ020032R0600	Steel actuator for JSNY4/5 safety interlock switches with flexible bend.
JSNY8/9N1	2TLJ020032R0400	Steel actuator for JSNY8/9 safety interlock switches, standard.
JSNY8/9N2	2TLJ020032R0500	Steel actuator for JSNY8/9 safety interlock switches, flexible.
JSNY8EO	2TLJ020032R2000	JSNY8EO Emergency opening button for JSNY8S
JSNY9S	2TLJ020036R0100	Safety interlock switch with power to unlock 24VAC/DC (1.1VA) solenoid, 1 NO & 1 NC positive opening contacts from actuator and 1 NO & 1 NC positive opening contacts from solenoid, 10A thermal current, 1000N locking force, IP67, plastic body, three M20 conduit entries, comes with metal actuator.
JSNY9SN2	2TLJ020036R0200	Safety interlock switch with power to unlock 24VAC/DC (1.1VA) solenoid, 1 NO & 1 NC positive opening contacts from actuator and 1 NO & 1 NC positive opening contacts from solenoid, 10A thermal current, 1000N locking force, IP67, plastic body, three M20 conduit entries, comes with flexible actuator.
JSNY9M	2TLJ020036R2100	Safety interlock switch with power to lock 24VAC/DC (1.1VA) solenoid, 1 NO & 1 NC positive opening contacts from actuator and 1 NO & 1 NC positive opening contacts from solenoid, 10A thermal current, 1000N locking force, IP67, plastic body, three M20 conduit entries, comes with metal actuator.
JSNY9MN2	2TLJ020036R2200	Safety interlock switch with power to lock 24 VAC/DC (1.1VA) solenoid, 1 NO & 1 NC positive opening contacts from actuator and 1 NO & 1 NC positive opening contacts from solenoid, 10A thermal current, 1000 N locking force, IP67, plastic body, three M20 conduit entries, comes with flexible actuator.

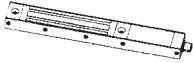
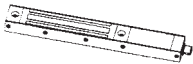
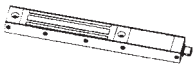
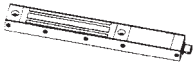



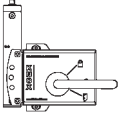
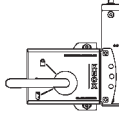
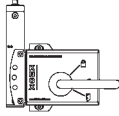
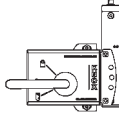
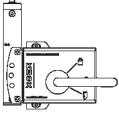
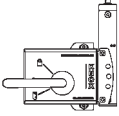
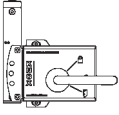
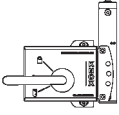
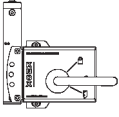
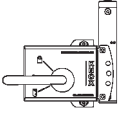

## Component List - Mechanical Switches

Designation	Ordering Information	Description
Magne 1A 	2TLJ042022R0000	Process lock, including anchor plate
Magne 1B 	2TLJ042022R0100	Process lock including anchor plate with built-in permanent
Magne 2A 	2TLJ042022R1000	Process lock with built-in Eden, including anchor plate.
Magne 2B 	2TLJ042022R1200	Process lock included. Anchor plate with built-in permanent magnet (30 N).
Magne 2Ax 	2TLJ042022R1300	Process lock with built-in Eden and 5-pin M12 connector for Urax, including anchor plate.
Magne 2Bx 	2TLJ042022R1400	Process lock with built-in Eden and 5-pin M12 connector for Urax, including anchor plate with built-in permanent magnet (30 N).
JSM D21B 	2TLJ042023R0500	Assembly kit for anchor plate.
JSMD2 	2TLJ042023R01000	Handle profile for JSM D21B.
JSM D23	2TLJ042023R0200	Fixture for sliding door.
JSM D24	2TLJ042023R0300	Assembly kit for Eva.
	2TLJ042023R0400	Anchor plate with permanent magnet.
JSMD2AGS 	2TLJ042023R0100	Magne protective handle mounting kit for use with Magne 1A and Magne 2A anchors and optional Evas on regular swing doors. Extruded aluminum profile completely hides the Magne unit when the door is closed. This handle can be used for both right and left doors as well as cable exit up or down.

## Component List - Mechanical Switches

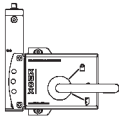
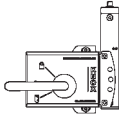
Designation	Ordering Information	Description
Knox 1A-R v2 	2TLJ020105R5000	Knox door part for outward-opening right-hung door.
Knox 1A-L v2 	2TLJ020105R5100	Knox door part for outward-opening left-hung door.
Knox 1B-R v2 	2TLJ020105R5200	Knox door part for inward-opening right-hung door.
Knox 1B-L v2 	2TLJ020105R5300	Knox door part for outward-opening left-hung door.
Knox 1AX-R v2 	2TLJ020105R5800	Knox door part for outward-opening right-hung door with the option for manual unlocking from the outside.
Knox 1AX-L v2 	2TLJ020105R5900	Knox door part for outward-opening left-hung door with the option for manual unlocking from the outside.
Knox 1F-R v2 	2TLJ020105R6000	Knox door part for sliding door that opens to the right. Including additional fastening fixtures for the frame.
Knox 1F-L v2 	2TLJ020105R6100	Knox door part for sliding door that opens to the left. Including additional fastening fixtures for the frame.
Knox 1BX-R v2 	2TLJ020105R6200	Knox door part for inward-opening right-hung door with the option for manual unlocking from the outside.
Knox 1BX-L v2 	2TLJ020105R6300	Knox door part for inward-opening left-hung door with the option for manual unlocking from the outside.

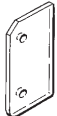
## Component List - Mechanical Switches

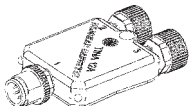
Designation	Ordering Information	Description
Knox 1FX-R v2 	2TLJ020105R6400	Knox door part for sliding door that opens to the right with the option for manual unlocking from the outside. Includes additional fastening fixtures for the frame.
Knox 1FX-L v2 	2TLJ020105R6500	Knox door part for sliding door that opens to the left with the option for manual unlocking from the outside. Includes additional fastening fixtures for the frame.
Knox 2A v2 	2TLJ020105R2200	Standard Knox frame part 8-pin M12 contact, supplied for right-hung door. For instructions for turning, see the Knox manual.
Knox 2X v2	2TLJ020105R2300	Knox process lock, no duplicate unlocking signal, with 5-pin M12 contact.
PC Plate for Knox on Mesh Door	2TLJ020106R0000	When mounting Knox on door with mesh the accessory PC plate for Knox is recommended. This is to avoid emergency opening from the outside.
Mounting Plate for Knox without Emergency Release	2TLJ020106R0600	When mounting Knox on a low door, it is recommended to replace emergency release handle to prevent opening from the outside by reaching over.
DA 1 	2TLJ020053R0000	Distance protective plate for Adam M12. Polycarbonate with 2.5mm thickness. Suitable for Adam 3m/10m/20m if necessary.
M12-CT0214 	2TLJ020060R0100	Extension cable 20cm, black PVC jacket with straight 5 pole M12 female, 8 pole M12 male connectors, 22AWG conductors, overall braid shield.
Tina 12A 	2TLJ020054R1800	Dynamic connection block, 2 ports for connecting up to 2 safety devices with dynamic signals and locking inputs. Ports are 8 pole M12 female quick disconnects. 8 pole M12 male quick disconnect for connecting the safety devices to the Vital 1 controller or Pluto Safety PLC. Multi-function status indicator LEDs, integrated information output 24VDC - 10mA.

This document and any attachments may include suggested specifications, drawings, schematics and similar materials from ABB Inc. Use of such information and/or documentation by the recipient is subject to and conditioned upon your acceptance of the terms of the General Document Disclaimer which can be found at [www.jokabsafety.com](http://www.jokabsafety.com). Your acceptance of the terms of such General Document Disclaimer is conclusively presumed unless you notify ABB in writing of your disagreement with the terms of such Disclaimer immediately upon receipt of this document and you return to ABB all specifications, drawings, schematics and similar materials provided to you by ABB.

# Notes



# Safety Control Devices

Meet existing safety standards!  
 Keep hands outside of risk area!  
 Safe stops and reliable restarts!

- Why should I use Safety Control Devices? ..... 9:2
- JSHD4 Three-Position Enabling Devices  
 The Safest Solution ..... 9:4
  - Standard Features and Options ..... 9:6
  - Cable/Connectors Accessories ..... 9:8
  - Pendant Holster ..... 9:9
  - Design a Three-Position Device ..... 9:10
  - Available Combinations and Accessories ..... 9:11
  - Technical Data ..... 9:12
  - Three-Position Devices for Different Types of Mounting ..... 9:12
  - Connection Examples ..... 9:13
- JSTD1 Safeball™ ..... 9:16
  - Technical Data and Electrical Connections ..... 9:17
  - Safeball Function ..... 9:18
  - Safeball Mounting ..... 9:19
  - JSTD25 Two-Hand Control Station ..... 9:20
- JSTD20 Conventional Two-Hand Control Device ..... 9:25
  - Technical Data and Electrical Connection ..... 9:26
- Component List and Ordering Information ..... 9:27

# Why should I use Control Devices?

...for the machine operator to be able to directly start and stop dangerous machine movement!



## Three-Position Enabling Devices

Three-position devices, hold-to-run devices and enabling devices are used during troubleshooting, programming and test running when no other safety components are possible or suitable. The device is held in the hand and...

*...the operator, in an emergency situation, can either press harder or entirely release the device to stop the machine.*



*JSHD4 Ergonomic Three-Position Devices with double three-position button, gives a stop signal when released or fully pressed in.*

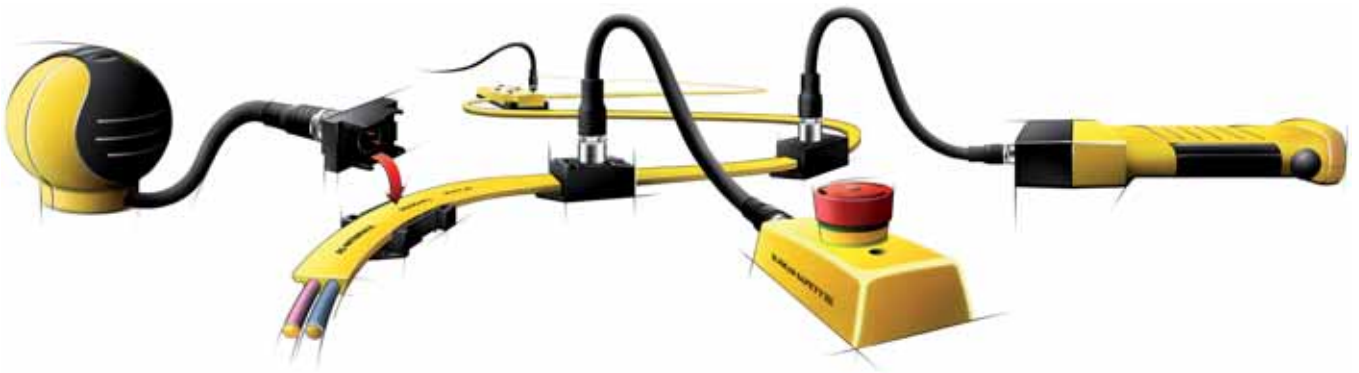

## Two-Hand Control Devices

A two-hand control device is used when it must guarantee that the operator's hands will be kept outside the risk area. If there is a risk that someone else other than the operator can reach into the machine without the operator seeing it, the safety device must be supplemented by something more—e.g. a light beam.

To be able to operate the machine with the two-hand device, all the buttons on the device have to be operated within 0.5 seconds of each other. This is called concurrence. All the buttons also have to be returned to their initial position before one can start again. If any button is released during the machine movement, the machine will be stopped. Using the stopping time, one can calculate the necessary safety distance. A safety distance of less than 100 mm must not be used.



*The two-hand device protects against “after-grasp”—if the operator by reflex tries to enter or reach into a machine during the dangerous machine movement.*

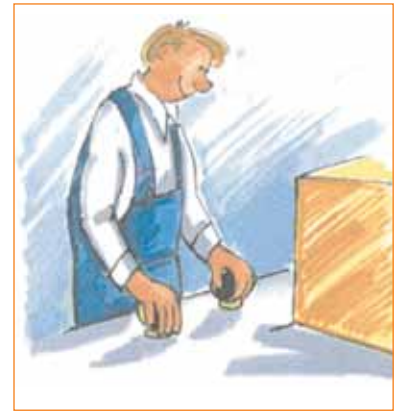

*JSTD1 Ergonomic Safeball is a two-hand control device with four built-in buttons.*



# JSHD4 Three-Position Enabling Devices: The Safest Solution during Troubleshooting, Programming and Testing

## Why choose three-position devices?

An operator who is under pressure must be able to give a stop signal, whether in panic they push harder on the button or just lets go of it. Three-position devices, hold-in and acceptance devices can be used for troubleshooting, programming and test running in situations where no other protection is available or feasible.

If the operator has to enter a risk area to troubleshoot or run a test, it is extremely important that they are able to stop the machinery without having to rely on someone else to stand by a stop button that is further away. In addition, no one else should be able to start the machinery from the outside after it has been stopped by use of the three-position device.

## Hold-to-Run Device vs Acceptance Device

**Hold to run device:** The start signal is given when the button is pressed. The stop signal is given when the button is released or pushed fully in.

**Acceptance device:** The start signal for separate starting is given when the button is pressed. The stop signal is given when the button is released or pushed fully in. "Separate start" means, for example, that a program start signal is sent to the robot via a separate button in the acceptance device.

## Ergonomic Design

The device is ergonomically designed—its shape, the way it fits the hand, and the way the buttons are operated. It is easy to operate the three-position device using just the fingers, and the middle position provides a secure resting position.

The device has LED indications that show the operational status, i.e. stop or ready signal. The two additional buttons can be used, for example, for start/stop, up/down or forward/back. Internally the device is duplicated. The three-position function itself is built up of two completely independent three-position buttons which are felt by the user to be one button.

## Cheat Safe Three-Position Device with Hand Recognition

The three-position device JSHD4 has sensors which ensure that it is a human hand holding it. By using this, the safety level is increased, and the risk of manipulation or bypass of the safety function is reduced. It is no longer possible to expose the operator or others to danger by trying to lock the three-position device in run mode.



## Applications

- Troubleshooting
- Test Running
- Programming

## Advantages

- Ergonomic
- LED Information
- Adaptable
- Cheat Safe
- Adapted for AS-i

## Regulations and Standards

The JSHD4 is designed and approved in accordance with appropriate directives and standards. See technical data.

## Approvals



## Three-Position Device Adapted for AS-i

The three-position device JSHD4 also comes in a version adapted for direct attachment to the AS-i bus.



## How does a three-position device work?

### Safety Level

A safe Enabling or Hold to Run device should function as follows:

1. The Stop signal in released (top) and bottom position shall have the same safety level.
2. Provide a 'Start' or 'Ready' signal in a distinct middle position.
3. After a 'Stop' in the bottom position, a 'Start' signal or 'Ready' signal is not permitted until the three position push-buttons have been totally released and again pressed to the middle position. This function is achieved mechanically within the three position push-buttons in the device.
4. A Short or Open circuit in the connection cables shall not lead to a dangerous function e.g. 'Start' or 'Ready' signal.

In order to meet the above conditions, the three-position switch must be connected to a suitable safety relay with a two channel function, e.g. RT6, RT9 or the Pluto Safety PLC, which can monitor that both three-position buttons are working and that there is no short or open circuit in the connection cable or the switch.

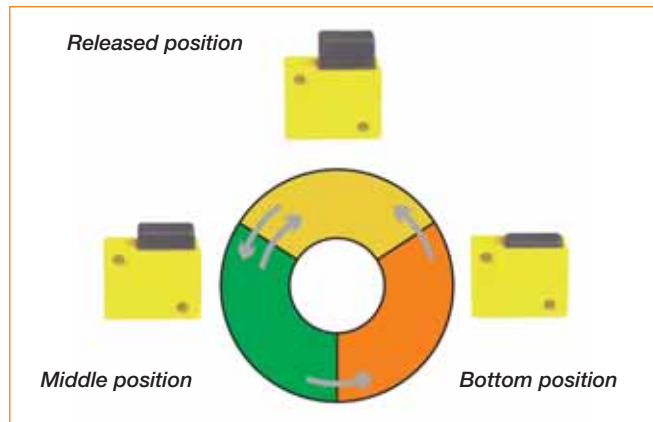

### Highest Safety Level whether the Button is Pushed or Released



*When the three position button is pushed all the way in you will obtain a dual stop. It is essential that the machine stops in an emergency situation.*



*When the three-position button is released you will obtain a dual stop. It is essential that the machine stops when you put aside the three-position device, for example during adjustment.*

## Three-Position Devices in Different Versions



*Three-position device fitted to a machine control unit.*



*Panel assembly of JSHD4H2 on a programming unit for robots.*



## Standard Features and Options

### Button Configurations

The 3-Position Enabling Device can have up to two auxiliary buttons on the front and top to be used for any functions the user desires. Common functions

such as jogging, start/stop, up/down or safety relay reset are achievable with one hand while maintaining the safety function.



Enabling Device with Top and Front Buttons

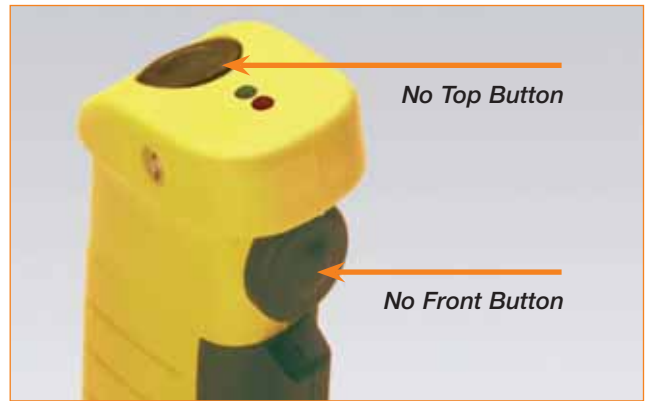

Enabling Device with No Auxiliary Buttons

### LED Options

One green LED and one red LED are standard as function indicators for the Enabling Device. When the Enabling Device is cycled to position 3, the start

function in position 2 is not reinitiated when the enabling button returns from position 3 to position 1.



**Position 1 (Red LED)  
STOP Function**

Enabling Button  
Not Pressed or Released



**Position 2 (Green LED)  
START Function**

Enabling Button  
Pressed to the Middle Position



**Position 3 (Red LED)  
STOP Function**

Enabling Button Pressed Down  
Fully Past the Middle Position

### Bottom Plate

The ABB Jokab Safety Enabling Device comes standard with a large bottom plate with provisions for mounting the actuators from the pendant holster JSNA-JSM-2A accessory. The large bottom plate accommodates both 5 pole and 8 pole connection types.



## Connection Types and Special Applications



**8 Poles Male Mini Series Size II Plug with Cable**  
Standard cable lengths of 20, 30 or 40 feet in oil resistant PVC and 20 or 30 feet in PUR cable. (8MP Designator)



**4 Poles Male Micro DC (M12) Plug with Cable**  
Standard cable lengths of 6, 10 or 15 meters in oil resistant PVC. (4MP Designator)

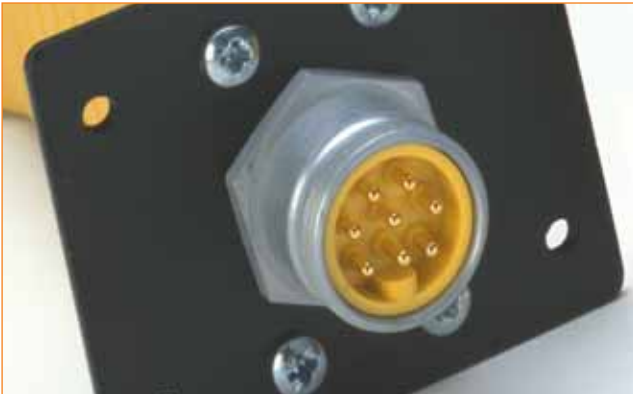

**8 Poles Male Mini Series Size II Receptacle**  
(8MR Designator)

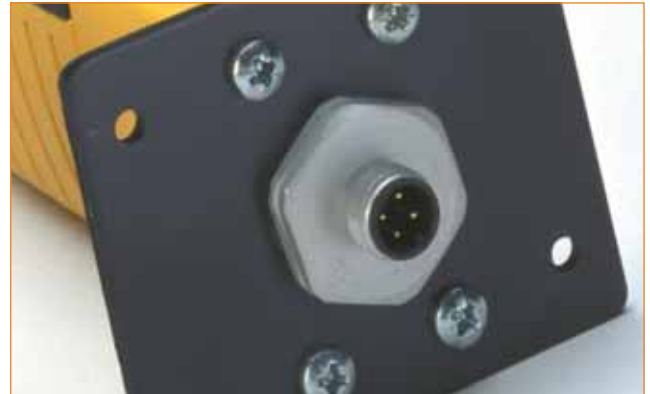

**5 Poles Male Micro DC (M12) Receptacle**  
(5MR Designator)



### 3-Position Switches

For customers who would like to retrofit or incorporate switches into existing robot teach pendants or other devices, ABB Jokab Safety offers three versions of our 3-Position Switches.



### Custom 3-Position Enabling Devices for Many Special Applications

The 3-Position Enabling Device can be customized to accommodate many special applications, including special cables, connection type or wiring configurations that are necessary to meet certain application criteria.

## Connection of Pluto Version Enabling Device to Pluto Safety PLC

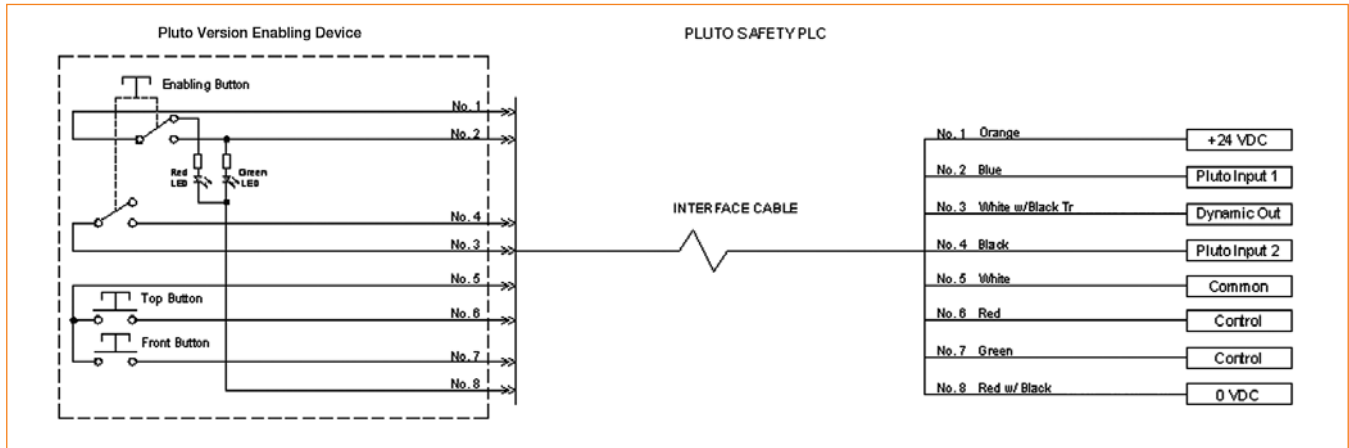

## Accessories



### 8 Pole Mini Series Size II

Available in standard cable lengths of 20, 30 or 40\* feet with 18AWG wire. Custom lengths are available upon request and are subject to a minimum quantity requirement. (\*only in PVC)



### 5 Pole Micro DC (M12)

Standard cable lengths of 10, 15 or 20 meters with 18AWG wire in PVC or 22AWG wire in PUR cable. Custom lengths are available upon request and are subject to a minimum quantity requirement.



### Panel Mount Receptacles

Both 8 Pole Mini Series Size II and 5 Pole Micro DC (M12) style female versions available with 1/2" NPT mounting and 18AWG wire.

Standard wire lengths of 12, 36 or 72 inches for the 8 pole style and 0.3 or 1 meter for the 4 pole style. Custom lengths are available upon request and are subject to a minimum quantity requirement.



### Terminating Plugs

Both 8 Pole Mini Series Size II and 4 Pole Micro DC (M12) style male versions available with pins 1-2 and 3-4 shorted.

## Pendant Holster

The pendant holster can be used for a variety of applications, including:

- Disabling of robot hazardous motion
- Disabling of external reset buttons to prevent unintentional start-ups
- Disabling of input devices to allow access to the hazardous area of other equipment within a cell, such as transfer stations, while using the enabling device

The non-safety N.O. contact on the pendant holster safety interlock switches can be used to provide a software or visual signal to indicate that the enabling device has been removed from the pendant holster.

### Interlock Switch Pendant Holster

The Enabling Device Pendant Holster consists of two safety interlock switches mounted to a U-channel wall mounting bracket. Each safety interlock switch contains two N.C. positive openings and one N.O. contact.

The actuator from each safety interlock switch is mounted to the standard large bottom plate of the enabling device. The enabling device is then inserted into the pendant holster. The safety interlock switches provide a very strong and secure holder for the enabling device while providing the customer user interface contact to perform various functions.

### Eden Pendant Holster

The Eden Enabling Device Pendant Holster consists of a two-piece metal bracket and is designed for use with the Adam and Eva non-contact, non-magnetic safety switch and the JSHD4 Enabling Device.

The top bracket (JSM53A) is formed to step-up near the center of the bracket. The lower end of this bracket is pre-drilled with four holes to attach the enabler pendant handle with screws and a M16 threaded opening for enabling device cable or bulkhead connector. The stepped-up end of the top bracket is drilled and tapped with two 4 mm holes to attach the Eva or Eva E side of the Eden Safety Switch. A beveled guide pin is welded to the underside of the stepped-up end of the top bracket and will fit into a pre-drilled hole with metal tube welded to the underside of the lower bracket.

The lower bracket (JSM54) is formed with a 90° angle that has pre-drilled holes for attachment to walls, panels or fencing. The rest of the bracket has two drilled and tapped 4 mm holes to attach the Adam or Adam E side of the Eden Safety Switch and is shaped to mate with the top bracket. This allows for the insertion of the guide pin into the pre-drilled hole and properly positions the Adam and Eva Safety Switch. The Eden Pendant Holster comes assembled with Enabling Device or can be ordered without the Enabling Device to retrofit your current enabling device.



## Design a Three-Position Device for your Needs

### 1. Choose between five different top units



- No LEDs
- No front button
- No top button

JSHD4-1  
2TLA020006R2100



- LEDs
- Front button
- Top button

JSHD4-2  
2TLA020006R2200



- LEDs
- No front button
- No top button

JSHD4-3  
2TLA020006R2300



- LEDs
- Front button
- No top button

JSHD4-4  
2TLA020006R2400

### 2. Choose a bottom part suitable for your assembly



AA, AH, AJ



AB



AC, AD



AF, AG



AE

AA	2TLA020005R1000 with cable gland
AB	2TLA020005R1100 with Cannon connection
AC	2TLA020005R1200 with M12 connection (5 poles)
AD	2TLA020005R1300 with M12 connection (8 poles)
AE	2TLA020005R1400 with M12 connection (8 poles) and emergency stop
AF	2TLA020005R1500 with M12 connection (4 poles) and 2 AS-i nodes (for front and top button)
AG	2TLA020005R1600 with M12 connection (4 poles) and 1 AS-i node (without front and top button)
AH	2TLA020005R1700 with cable gland and PCB with 10 screw connections
AJ	2TLA020005R1800 with cable gland and PCB with 16 screw connections

### 3. Choose hand recognition for making your three position device cheat protected (option)



Anti-tamper PCB – 2TLA020005R0900

### 4. Check the chart (above right) to see if your combination is available

### 5. Choose a bottom plate (option)



JSM50G, bottom plate for Safety Interlock switch JSNY5  
2TLA020205R6300



JSM50H, bottom plate for non-contact sensor Eden (Eva)  
2TLA020205R6400

## Available Combinations of Bottom and Top Parts

	JSHD4-1	JSHD4-2	JSHD4-3	JSHD4-4	JSHD4-5
AA without Cheat Safe	JSHD4-1AA	-	-	-	-
AA with Cheat Safe	-	-	-	-	-
AB without Cheat Safe	-	JSHD4-2AB	JSHD4-3AB	JSHD4-4AB	JSHD4-5AB
AB with Cheat Safe	-	JSHD4-2AB-A	JSHD4-3AB-A	JSHD4-4AB-A	JSHD4-5AB-A
AC without Cheat Safe	JSHD4-1AC	-	-	-	-
AC with Cheat Safe	-	-	-	-	-
AD without Cheat Safe	-	JSHD4-2AD	JSHD4-3AD	JSHD4-4AD	JSHD4-5AD
AD with Cheat Safe	-	JSHD4-2AD-A	JSHD4-3AD-A	JSHD4-4AD-A	JSHD4-5AD-A
AE without Cheat Safe	-	-	JSHD4-3AE	-	-
AE with Cheat Safe	-	-	-	-	-
AF without Cheat Safe	-	JSHD4-2AF	JSHD4-3AF	JSHD4-4AF	JSHD4-5AF
AF with Cheat Safe	-	JSHD4-2AF-A	JSHD4-3AF-A	JSHD4-4AF-A	JSHD4-5AF-A
AG without Cheat Safe	-	-	JSHD4-3AG	-	-
AG with Cheat Safe	-	-	-	-	-
AH without Cheat Safe	-	JSHD4-2AH	JSHD4-3AH	JSHD4-4AH	JSHD4-5AH
AH with Cheat Safe	-	JSHD4-2AH-A	JSHD4-3AH-A	JSHD4-4AH-A	JSHD4-5AH-A

## Three-Position Enabling Device Accessories



Cable, Available in Different Lengths



Spiral Cable, Available in Different Lengths



JSHK0 12 Pole Connector for JSHD4



JSHD4 Protection Coat



JSM55 Wall Bracket for Three-Position Device



Cable Drum



JSM5B Wall Bracket for Interlock Switches and Three-Position Device

## Technical Data - JSHD4 Enabling Device

Manufacturer	ABB AB/Jokab Safety, Sweden
Ordering information	see pages 9:27-9:32
Safety level EN ISO 13849-1	Category 4/PL e
Electrical contact ratings Three-position button	30 VDC, max 0.5 A (min. 10 mA, 10V)
Extra button	50 VAC/DC max 0.2 A
Protection class	IP 65
Operating temperature	-10 to +50° C
Function indication Three-position buttons ready signal	'Yes', green LED 'No', red LED
Material	Polyamide 6.6
Insulation resistance	min 20 M Ohm
Operation force	approx. 15 N
Mechanical life	1 000 000 cycles to middle position
Conformity	AFS 1994:48, EN ISO 12100-1/-2, EN 954-1/EN ISO 13849-1

Pin	Color STD	Color JSHK-S
A	White	White
B	Brown	Brown
C	Green	Green
D	Yellow	Yellow
E	Grey	-
F	Pink	Grey
G	Blue	Pink
H	Red	Blue
I	Black	Red
J	Purple	-
K	-	-
L	-	-

STD: JSHK, JSHK-E, JSHK-T

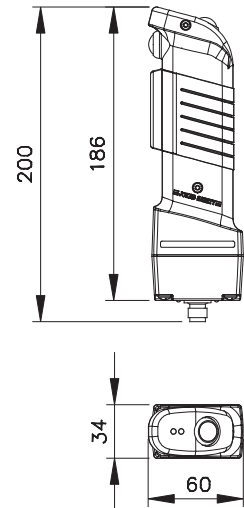

## Three-Position Devices for Different Types of Mounting

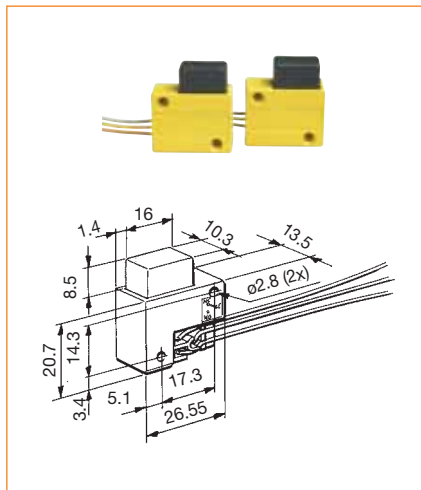

### 3-Position Push Button JSHD2C

The button is the main component in a safe three-position solution. To achieve the highest safety level two buttons are used in a two-channel system.

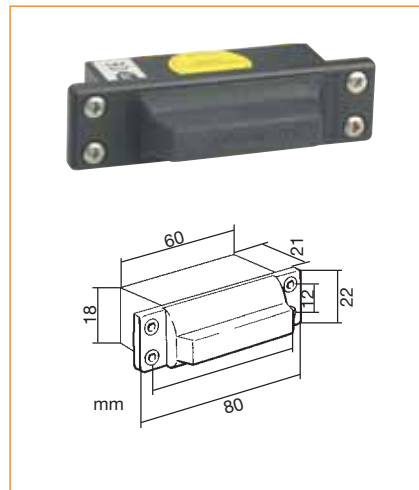

### Panel Assembly JSHD4H2

A panel assembly suitable for building into programming units or similar control boxes. Provides simultaneous activation of both of the three-position buttons.

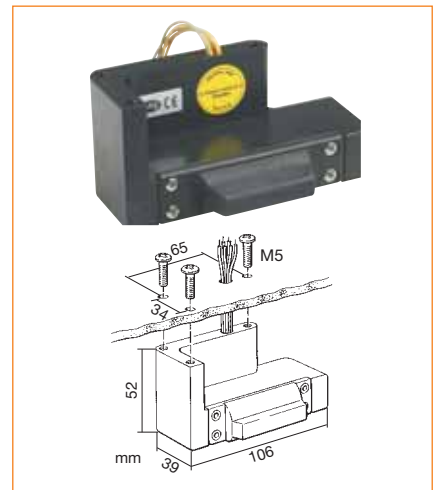

### External Assembly JSHD4H2A

The external assembly is similar to the panel assembly unit, although it is a 'handle' design making it suitable for assembly on the outside of a control box.



# JSHD4 Connection Example

## Three-Position Device JSHD4 to Pluto

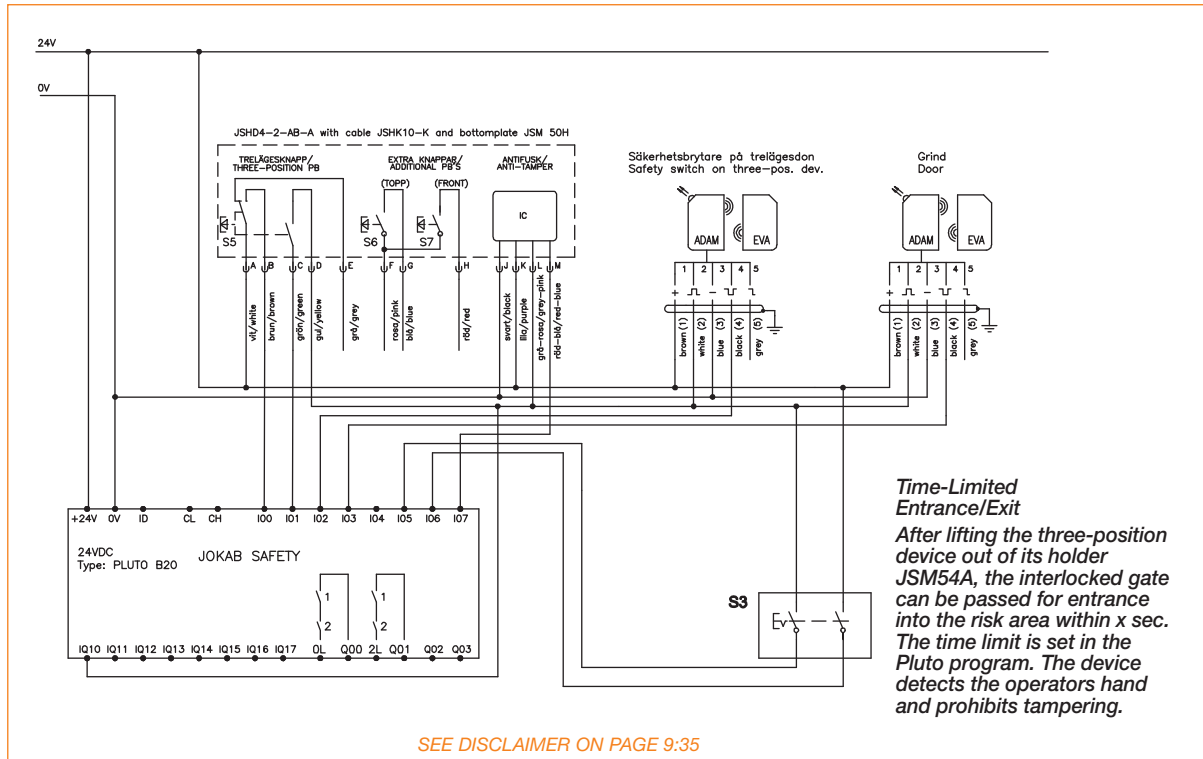

# JSHD4 Connection Example

## Three-Position Device JSHD4 with Various Safety Controllers

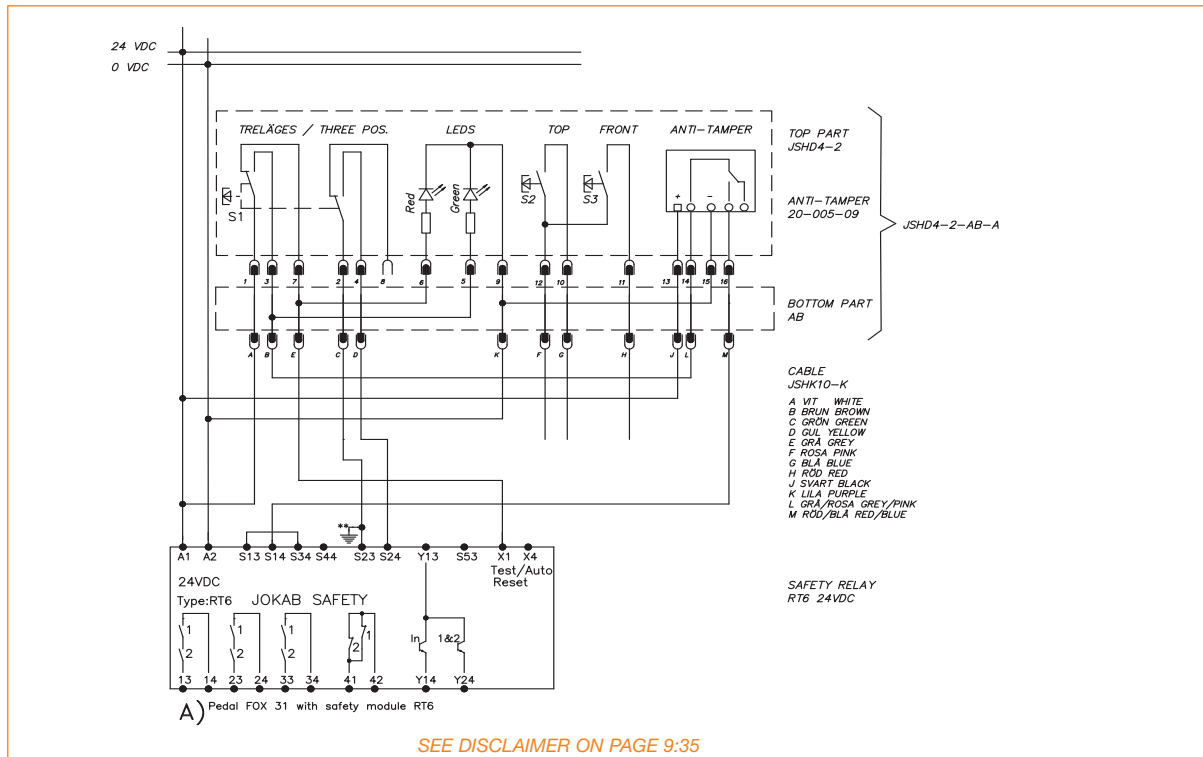

## JSHD4 Connection Example

### Connection with bottom parts AB

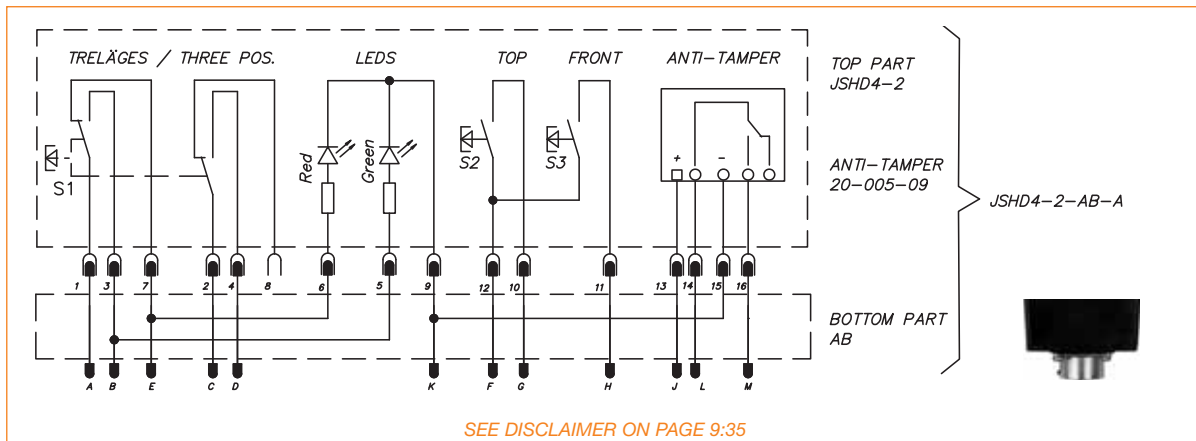

## JSHD4 Connection Example

### Connection with bottom parts AC

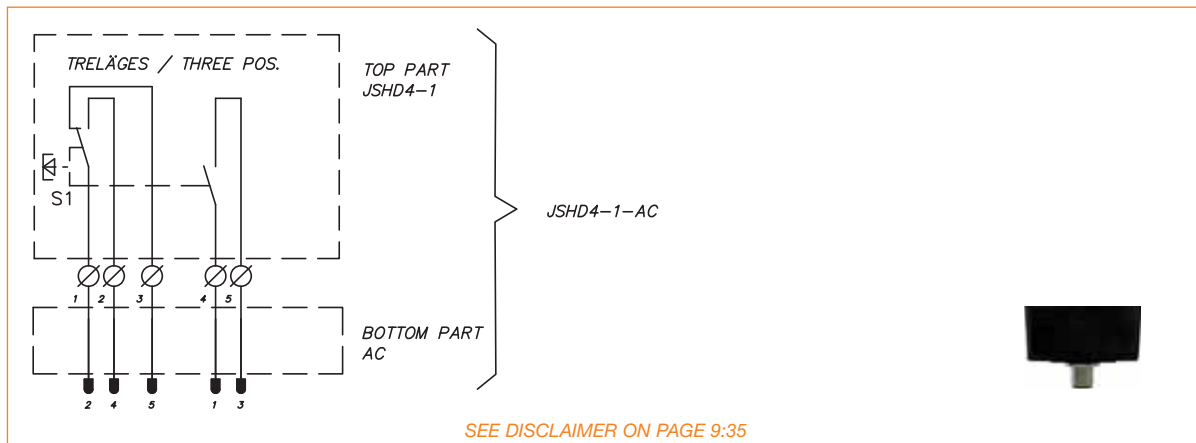

## JSHD4 Connection Example

### Connection with bottom parts AD

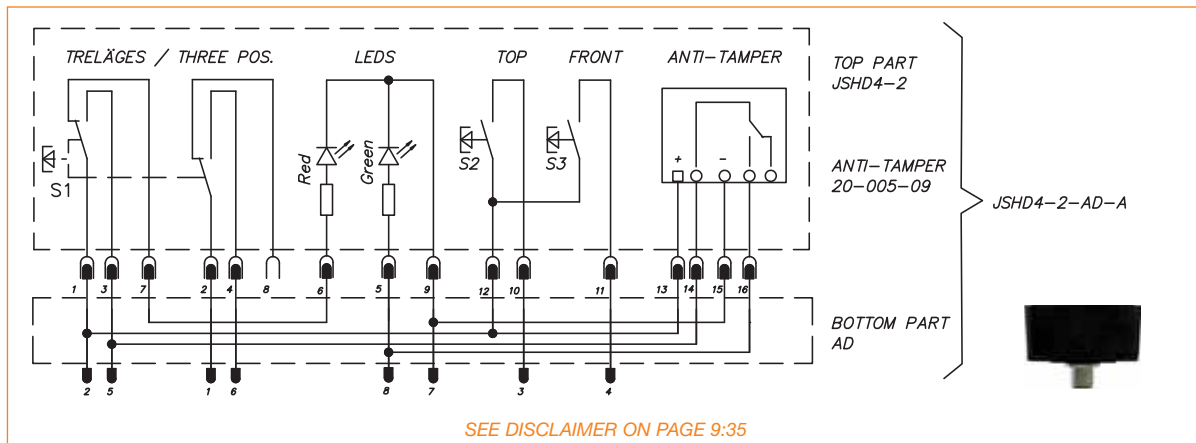

## JSHD4 Connection Example

### Connection with bottom parts AE

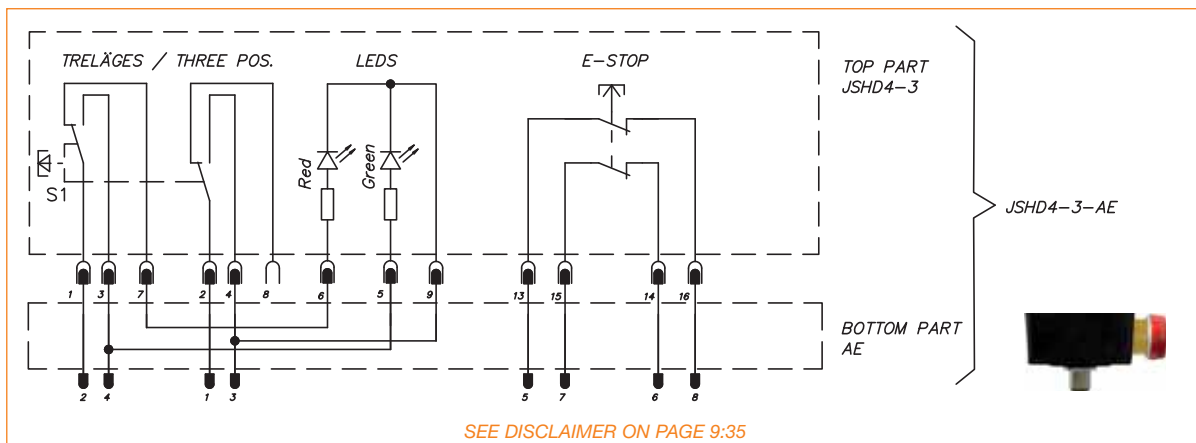

## JSHD4 Connection Example

### Connection with bottom parts AH

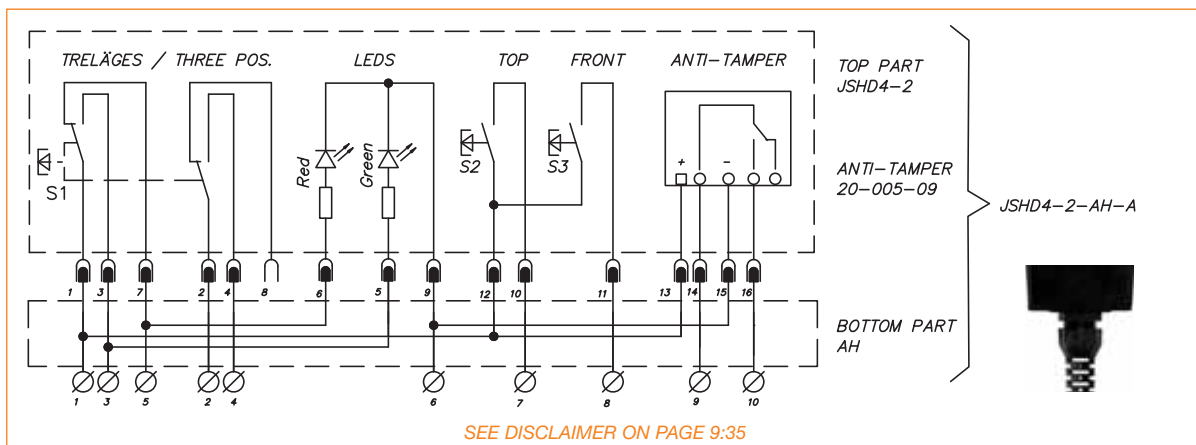

## JSHD4 Connection Example

### Connection with bottom parts AJ

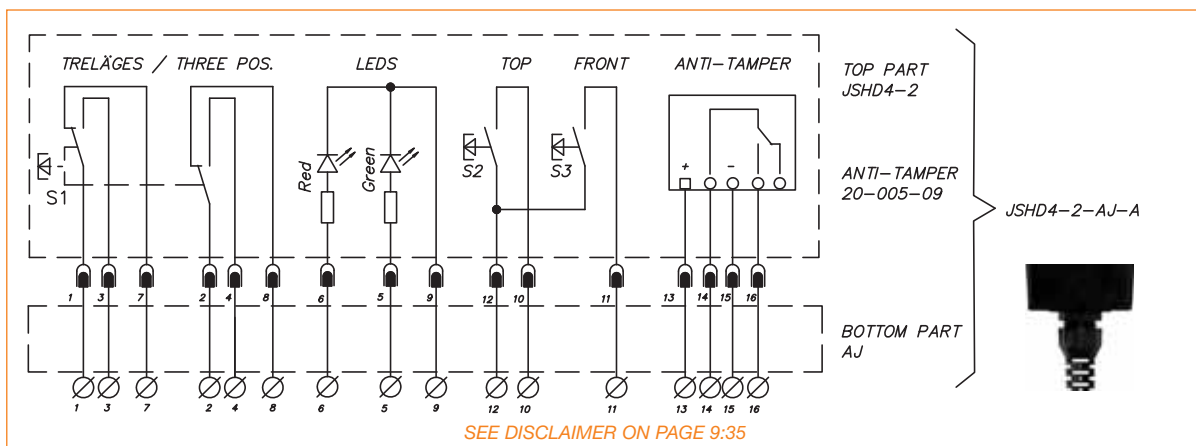

# JSTD1 Safeball™

## A Unique New Category 4 Two-Hand Control Device

Safeball is a completely new approach to the design of one and two-hand safety devices. Instead of the conventional approach using ordinary push buttons and non-ergonomic protection for unintentional activation, a 'hands on' approach has been developed. Safeball consists of a spherical ball containing two embedded push button switches, one on each side of the ball. By using this push button configuration, the risk of unintentional activation is minimized and the device is simple and ergonomic to use.

Safeball can be utilized for either one-hand (one Safeball) or two-hand (two Safeballs) applications. In either application, and in order to meet the required level of safety, the Safeball(s) switches are monitored by specified/certified ABB Jokab Safety safety relays or Pluto Safety PLCs.

In the case where two-hand control is used, both Safeballs i.e. all four push buttons have to be activated within 0.5 seconds. If one or more push buttons are released a stop signal is given to the machine. In order to provide the highest level of safety the Safeball design provides the operator with a dual switching function and short circuit supervision in each hand.

Each Safeball is ergonomically designed and has both its cover and actuator made of environmental friendly polypropylene. The design allows for comfort of use for all hand sizes and operation from numerous gripping positions. Mounting of the Safeball is also very flexible allowing the device to be mounted in the most ergonomic position for the operator.

### Two-Hand Controls vs One-Hand Controls

A two-hand control can be used when it is necessary to ensure that the operator is outside and must be prevented from reaching into the hazardous area. If the operator decides, after the start signal has been given to the machine, to make an 'after grasp' i.e. try to adjust the part that has been placed into the machine, then a dual stop signal is given to the machine.

A one-hand control device can be used when the operator cannot reach the hazardous area with his/her free hand or on less dangerous machines.

### High Safety Level

The Safeball is certified by Inspecta in Sweden for use as a two-hand control device, when used with a JSBR4 ABB Jokab Safety safety relay or Pluto Safety PLC, in accordance with the highest safety level in standard EN 574 (type IIIc).

### Two-Hand Device Adapted for AS-i

The two hand device, Safeball also comes in a version adapted for direct attachment to the AS-i bus.



JSTD25A  
Mounting Station

### Applications

- Presses
- Punches
- Fixtures
- Shearing machines

### Features

- Ergonomic design
- Low activation force
- Flexible mounting
- Several grip possibilities
- Highest safety level (category 4)
- Two-channel switching in each hand

### Regulations and Standards

The JSTD1 Safeball is certified by DNV. approval numbers are 01-MAL-CM-0101 (two-hand device) and 01-NAL-CM-0100 (one-hand device).

### Approvals



## JSTD1 Safeball Technical Data

Manufacturer	ABB AB/Jokab Safety, Sweden
Ordering information	see pages 9:32 - 9:34
Material	Polypropylene
Color	Yellow and black
Size	
Height	approx. 71 mm
Diameter, min.	68 mm
Diameter, max	72 mm
Diameter, base	42 mm
Weight	0.2 kg with 2 m cable 0.7 kg with 10 m cable 0.1 kg with 4x0.2 m wires
Safety level	
EN ISO 13849-1	Up to category 4/PLe
EN 954-1	Up to category 4
Temperature	
Operating	0°C to +55°C
Storage	-20°C to +70°C
Protection class	IP67. Not intended for use under water
Operating force	Approx. 2 N
Actuator travel	1.3 +/- 0.6 mm
Max switching load	30 V 2A DC, resistive load
Recommended load	24 V 10mA DC
Min switching load	6V 10mA DC, resistive load

Contact resistance	100 mohm
Life, mechanical	> 1x10 <sup>6</sup> operations at max. 1 Hz
Life, electrical	Dependant upon electrical load characteristics
Connection cable	
JSTD1-A	2m PVC-cable, 4 x 0.75mm <sup>2</sup>
JSTD1-B, JSTD1-E	4 x 0.75mm <sup>2</sup> wires, approx. 0.2 m
JSTD1-C	10 m PVC-cable, 4x0.75 mm <sup>2</sup>
Conformity	EN ISO 12100-1:2003, EN ISO 12100-2:2003, EN 574+A1:2008

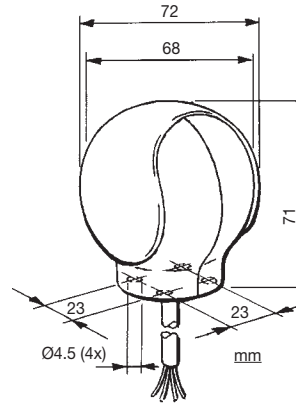

Chemical resistance at 20°C	
Chemical	Resistance
Alcohols	good
Paraffin oil	good
Milk	good
Silicon oil	good
Acetone	good
Please contact us for more information.	

## JSTD1 Safeball Electrical Connections

### Two-Hand Control Device

The Safeballs are designed to be connected to an ABB Jokab Safety JSBR4 safety relay or safety PLC to achieve the requirements for a two-hand device. By connecting the Safeballs in this electrical configuration Type IIIc, the highest safety level according to European standard EN 574 is achieved.

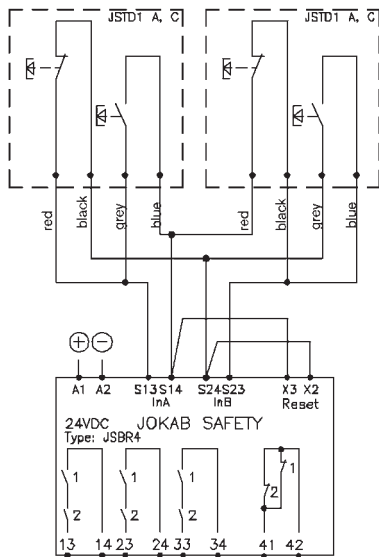

Example of two Safeballs connected to Jokab Safety relay JSBR4. The reaction time at 'stop' is < 15 ms.

### One-Hand Control Device

When used as a one-hand device the Safeball is designed to be connected to an ABB Jokab Safety RT6, RT7 or RT9 safety relay in order to achieve the highest possible safety level for this type of control.

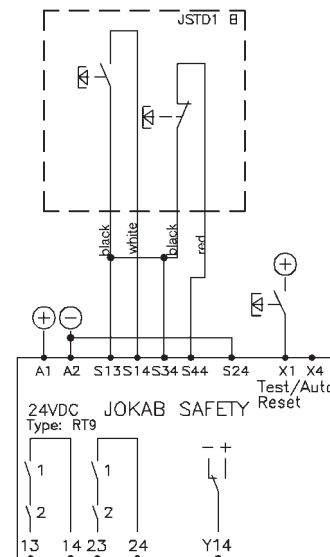

Example of a single Safeball connected to Jokab Safety relay RT6. The reaction time at 'stop' is < 20 ms.

## JSTD1 Safeball Function

### Two-Hand Control Device

The two-hand control device is made by using two Safeballs, each having two internal push buttons. The Safeballs must be mounted a minimum distance between each other (see mounting specifications on page 9:19). By utilizing two push buttons in each device a double safety function is provided in each hand.

The highest safety level is achieved by connecting all four push buttons to the ABB Jokab Safety JSBR4 safety relay or Pluto Safety PLC. The safety controller gives a dual and supervised safety function and requires input activation within 0.5 seconds in order to start the machine. It also checks that all four push buttons have returned to their deactivated positions before a new start is allowed. The safety controller also provides a stop signal if one or more push buttons are released.

### One-Hand Control Device

Safeball is also a very practical method of providing a one-hand control device as it is very easy to find and activate by the machine operator. One-hand devices should only be used when the operator cannot reach into the hazardous area with his/her free hand or on less dangerous machines. Before installation necessary risk assessment must be made to determine suitability of this type of control. To achieve the highest safety level for one-hand control the Safeball must be connected to the ABB Jokab Safety RT6 safety relay.

### Versions

Safeball is available in several versions to meet different environmental conditions and mounting methods.

**JSTD1-A** The standard version with actuators made of plastic and 2 m cable.

**JSTD1-B** Made as standard version but without cable. Instead it has four wires each 0.20m long.

**JSTD1-C** Same as JSTD1-A but with 10 m cable.

**JSTD1-E** Same as JSTD1-B but with 2 NO contacts.

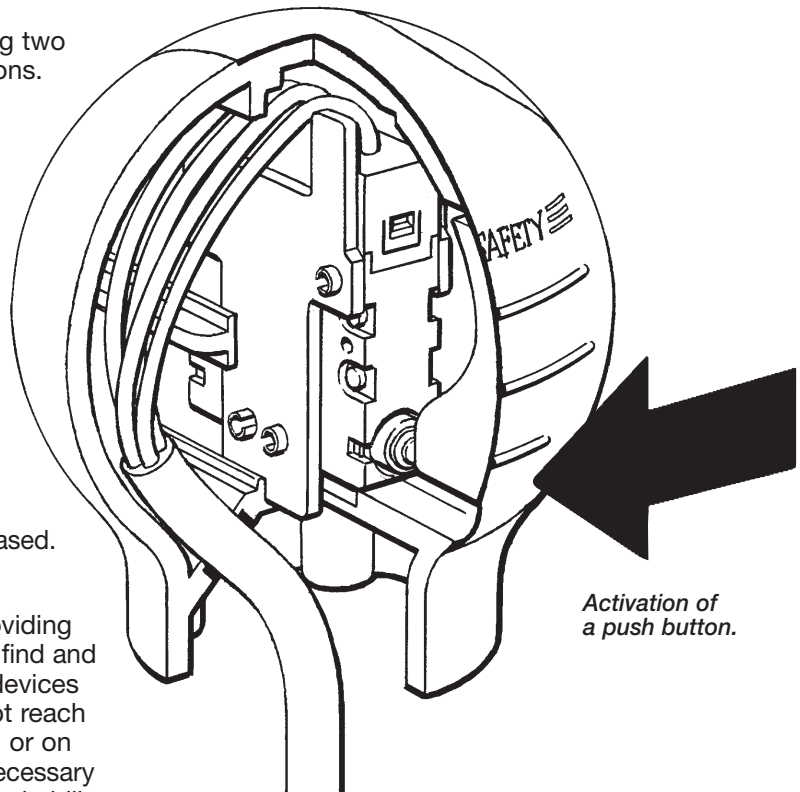

*Activation of a push button.*

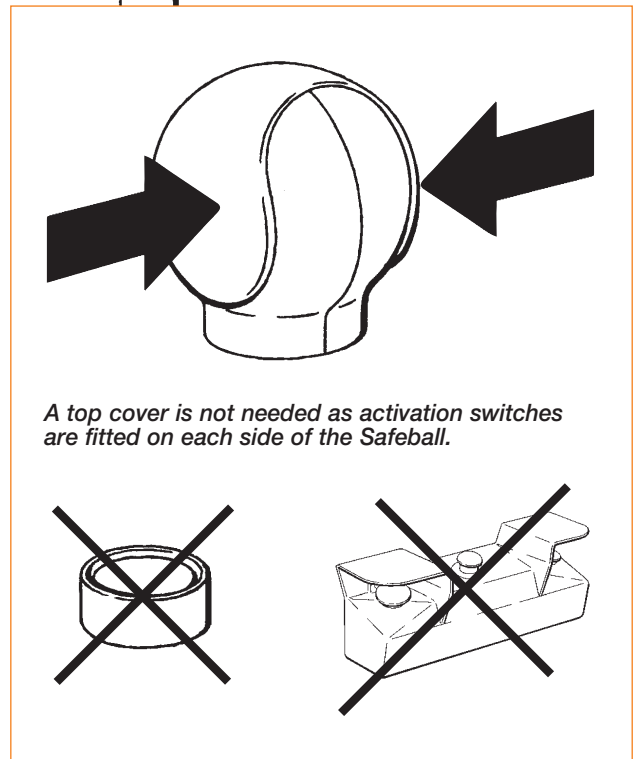

## JSTD1 Safeball Mounting

The Safeballs can be mounted in many different ways. They can be mounted on a table, a machine, on a support or wherever suitable for ergonomic reasons. The Safeball can be mounted in a fixed position or on a tilt and rotational support. This flexibility of mounting permits the Safeball to be fitted in the best ergonomic position for the ease of operation by the operator.

The distance requirement between two Safeballs or between a Safeball and a wall or edge of a table depends on how the Safeball is mounted. Safeball can be mounted with four M5 screws or ST4.8 self-tapping screws. If required, the connection cable can be taken out at the side of the lower part of the Safeball. There are two prepared outlets provided for this purpose.

### Mounting Methods

To be an approved two-hand device, both Safeballs must be mounted a minimum distance apart in order to prevent operation of both balls with one hand. Safeballs must be fitted a minimum distance from edges of tables or a wall.

It is essential that Safeballs are correctly installed in order to prevent unintended activation of the devices with part of the body in combination for example with a wall.

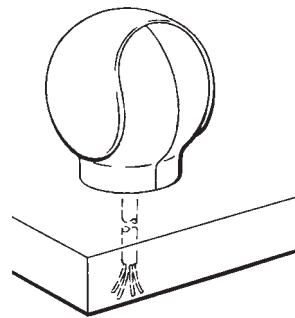

Mounting on a table.

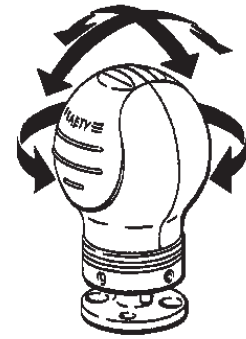

Mounting with ball joint, which can be rotated and angled.

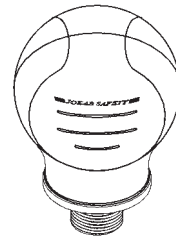

Mounting with 22 or 30 mm threaded adapter

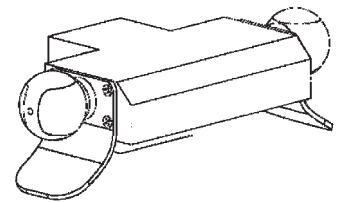

Example of alternative mounting method.

*Note: When Safeballs are mounted in such a way that the distance between them can be adjusted to less than the specified minimum, the mounting screws must be locked to ensure any changes in the distance between the two balls cannot be made.*

### Mounting Distance

Table mounting two Safeballs. In order to prevent cheating, the distances shown are the minimum allowed.

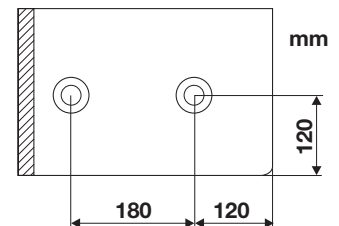
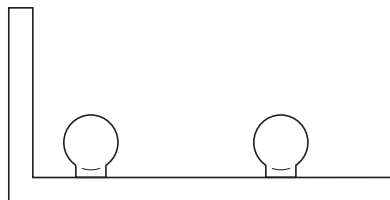

### Safety Distance

The Safety distance is the distance between the Safeballs and the dangerous machine movement. The safety distance requirement can be calculated using the following formula for Safeball according to approving authority and EN ISO 13855:

$S = KxT + C$  where—  
 S = safety distance in mm  
 K = hand speed, 1600 mm/s  
 T = total stopping time for the dangerous movement  
 (including the response time of the safety controller in seconds)  
 C = Constant = 0 mm for Safeball

*Note: S must never be less than 100 mm.*

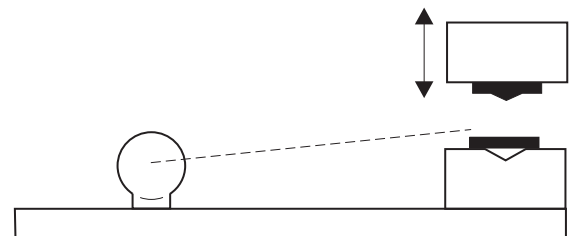

Safety distance is the distance between the Safeballs and the dangerous machine movement.

## JSTD25 Two-Hand Control Station with €

With a JSTD25 you have a prepared two-hand station that is easy to install, while utilizing the good ergonomics of the Safeball. There are several variants to meet differing needs. All versions meet EN 574, EN954-1 and EN13849-1 and are supplied with the internal connections made to simplify installation.

### JSTD25A/B/D/E for Fixed Installation

JSTD25A, B, D and E are supplied with two Safeballs mounted on steel housing and replaces a traditional two-hand device. It is available with an emergency stop button and ball joint fixtures for the Safeballs.

Three 22mm openings are prepared on the top for buttons or signal lamps. A hatch is supplied for wire routing in the base and securing holes for mounting on the rear. The Safeballs are connected to terminal blocks for the user to connect the external wiring through one of the two inlet alternatives (underneath



*JSTD25A Two-Hand Control Unit with 2 Safeballs*



*JSTD25B Two-Hand Control Unit with 2 Safeballs and Emergency Stop Button*



*JSTD25D Two-Hand Control Unit with two Safeballs mounted with two JSM C5 Ball and Socket Table Mounts*



*JSTD25E Two-Hand Control Unit mounted with two JSM C5 Ball and Socket Table Mounted Safeballs and Emergency Stop Button*

## JSTD25A/B/D/E Accessories

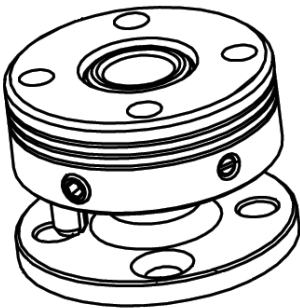

*JSM C5 Angled Ball Joint for installation of a Safeball on a table or a steel housing. Included on JSTD25D and JSTD25E (see above).*

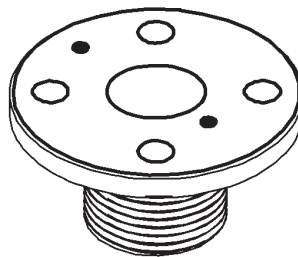

*JSNA-SB Adapter for mounting Safeball in any opening designed to hold standard 22 mm or 30 mm devices.*

*JSTS31 Stand with spacer ring for JSTD25A-E*

*JSTS30 Stand without Spacer Ring for JSTD25A-E*

*Adjustable Height 850-1100 mm*





# JSTD25 Dimension Sketch

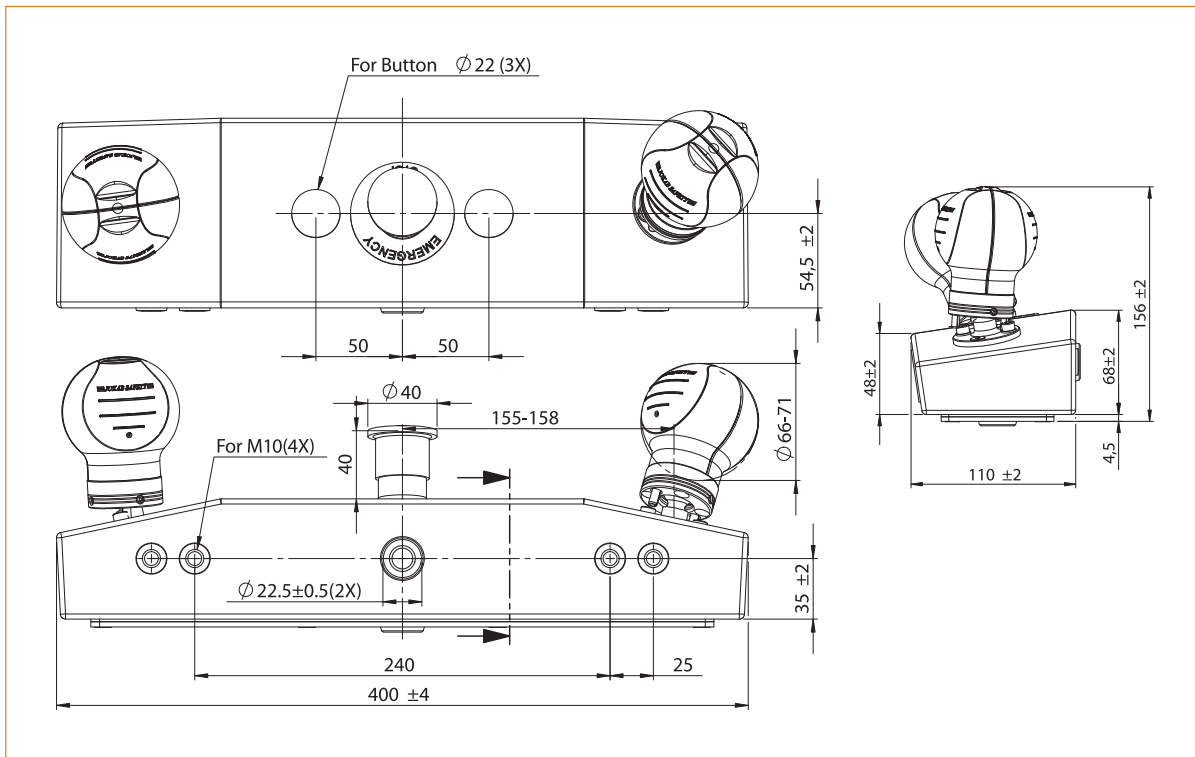

# JSTD25/A/B/D/E Connection Example

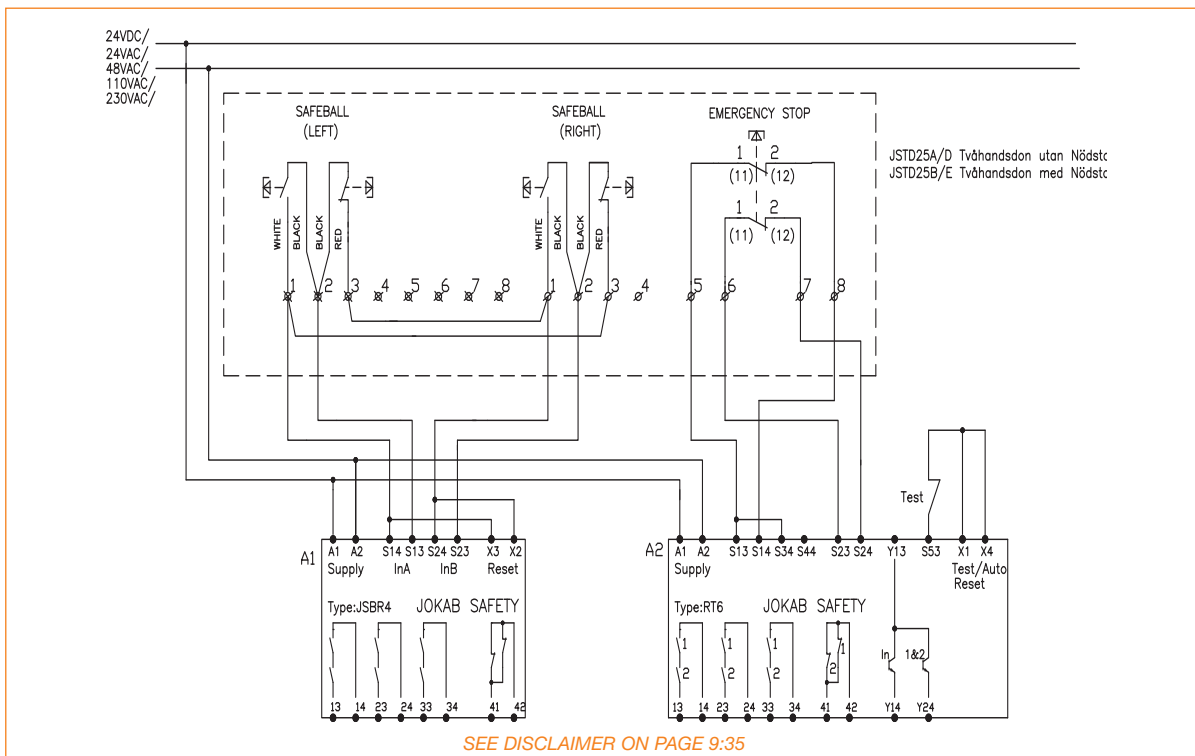

### JSTD25F/G for Mobile Installation

JSTD25F is supplied with two Safeballs mounted on the ends of an aluminum profile, shielded by over hand guards and replaces a traditional two-hand device. It is installed with the aid of grooves in the aluminum profile. It is connected to an M12 connector underneath.

The JSTD25F can be equipped with an external Smile Emergency Stop and an Eden Sensor for position control. Its low weight makes this particularly suitable for frequent repositioning.



*JSTD25F Two-Hand Control Unit with 2 Safeballs is suitable for frequent repositioning.*

JSTD25G is similar to JSTD25F except the dimensions, additional equipment and type of connection can, to a large extent, be customized before delivery. It can also be equipped with doubled protection plates for use in particularly severe conditions.



*JSTD25G Two-Hand Control Unit with 2 Safeballs can be customized for your particular application.*

### JSTD25P-1 for Mobile Installation with a Built-In Eden Sensor

JSTD25P-1 is supplied with two Safeballs mounted on the ends of an aluminum profile, shielded by over hand guards and is portable. It includes a built-in Eden Sensor for position control.

The JSTD25P-1 was developed as a portable two-hand device where the response of the machine to operation can vary at different operating stations — since each station can be connected separately. Connection is made via an 8+1 Zylind connector. Accessories include a connector, spiral cable with connector and universal suspension shelf.



### JSTD25P-1 Accessories



*JSMC14 Universal Suspension Shelf*



*JSTK40S 4 m long Spiral Cable with Connector*

*JSTK80S 8 m long Spiral Cable with Connector*

## JSTD25F/P-1 Dimension Sketch

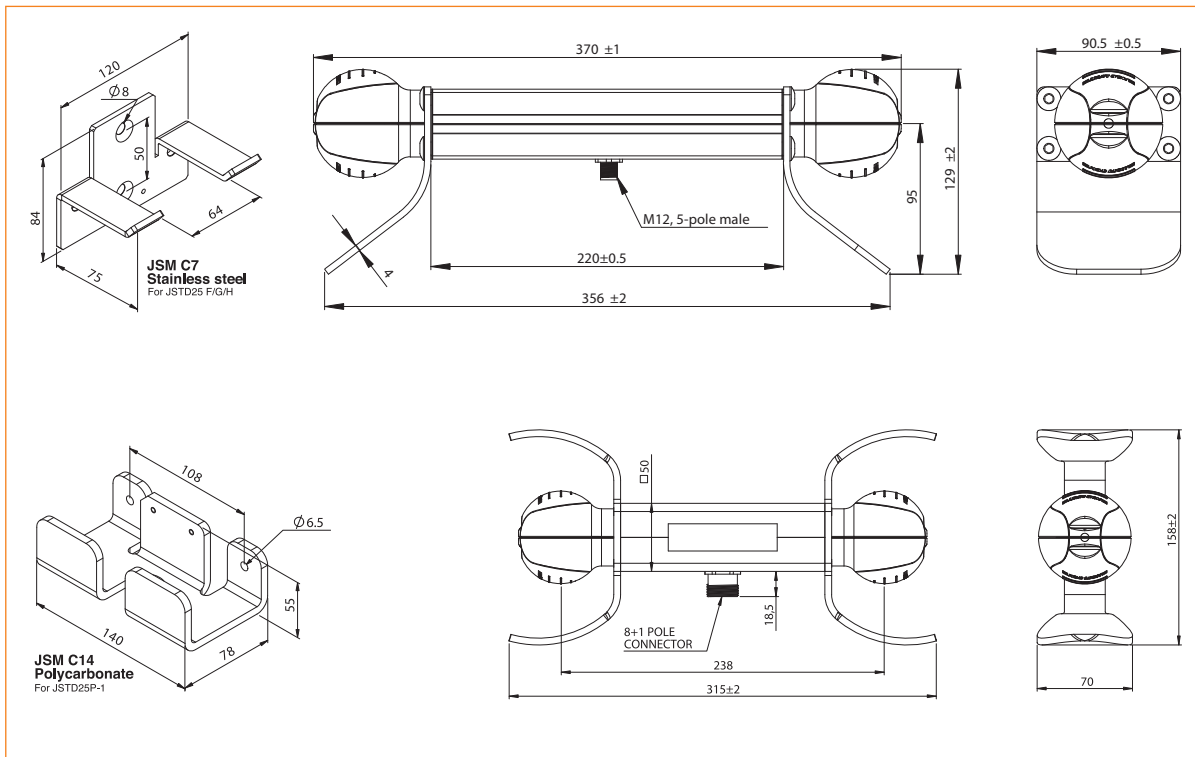

## JSTD25F Connection Example

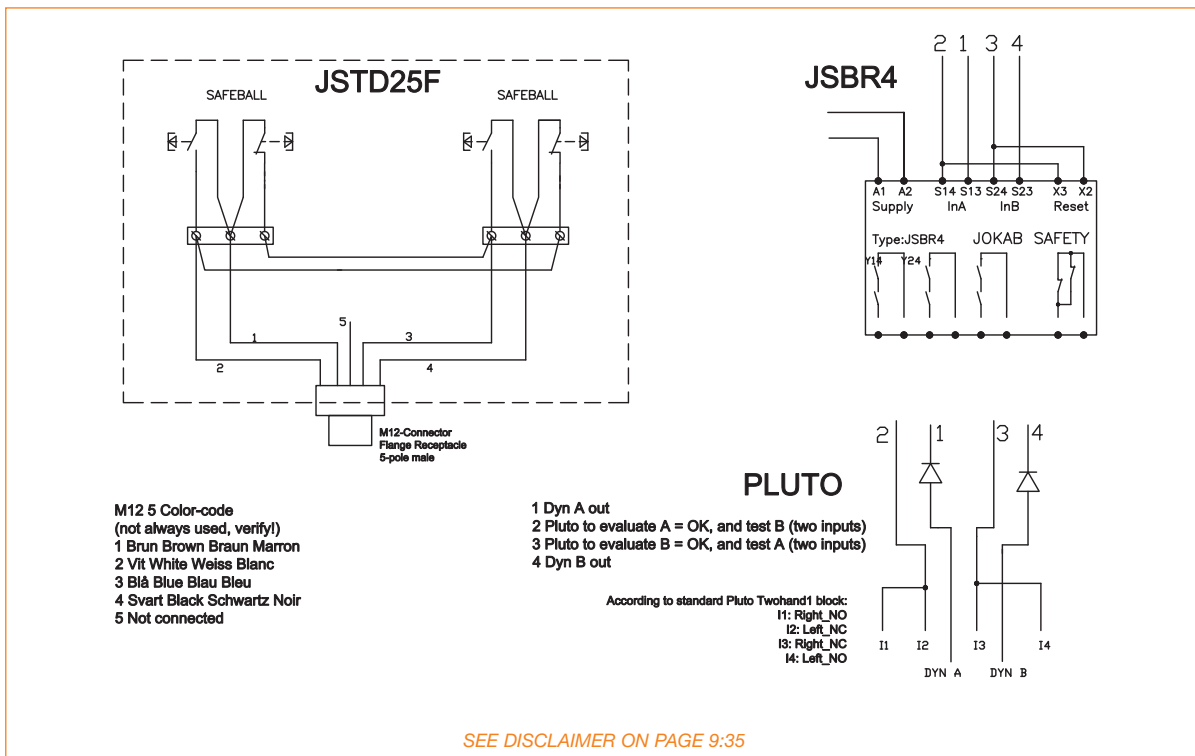

## JSTD25H Connection Example

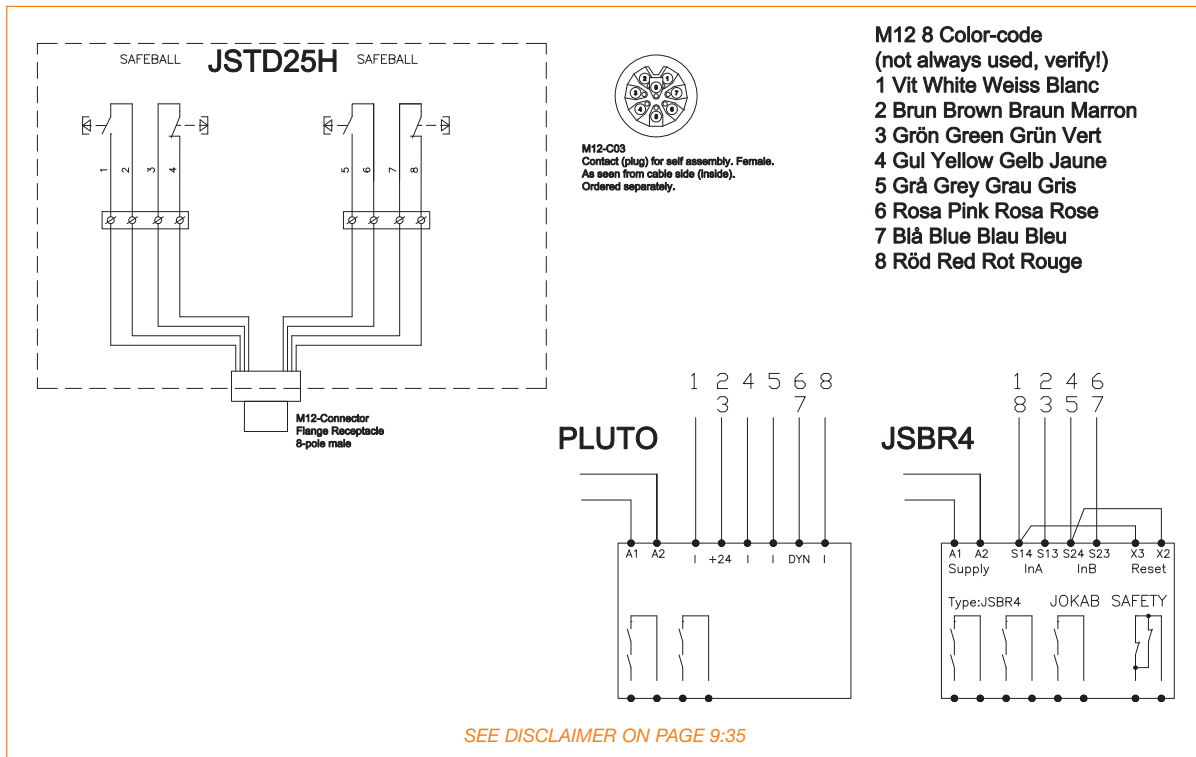

## JSTD25P-1 Connection Example

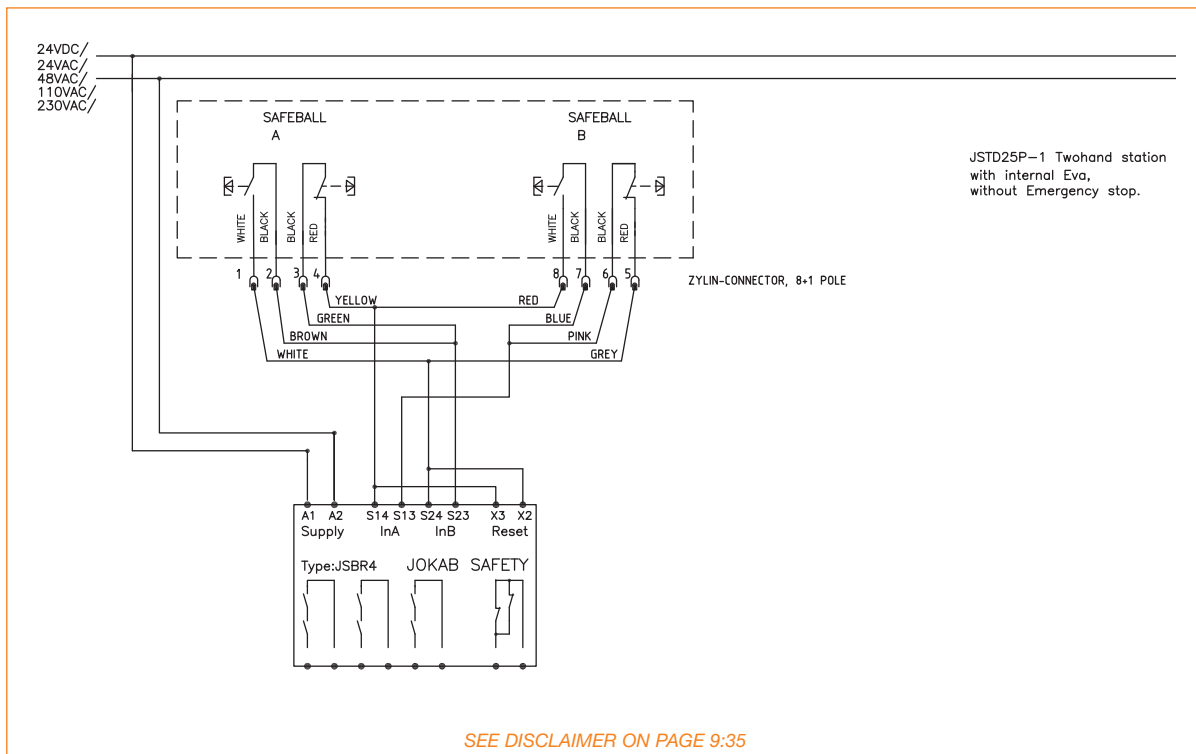

# JSTD20 Conventional Two-Hand Control Device

The conventional JSTD20 two-hand device utilizes a welded steel housing. Two operating push buttons are protected by over hand flanges. Between these push buttons there is space for a emergency push button and two extra controls or indication lamps. Below each of the operating push buttons is one normally open and one normally closed contact. To start and run the machine both push buttons must be activated within 0.5 seconds. If one or both push buttons are released a stop signal is given to the machine, and all contacts must return to their deactivated positions before a new start is allowed.

The design is robust and can withstand harsh environments and long use. The push buttons and contact blocks are easy to assemble for quick and easy installation. The device can be mounted directly on the machine, on the ABB Jokab Safety fencing system or on the JSTS30 floor mount. For use with movable Two hand devices the JSTS31 floor mount, which is provided with a distance ring to fulfill the requirements of EN 574, is recommended. The JSTD20 is available with or without emergency stop push button.

## Why use a two-hand device?

A two hand device can be used when it is necessary to ensure that the operator is outside and must be prevented from reaching into the hazardous area. If the operator decides, after the start signal has been given to the machine, to make an 'after grasp' i.e. try to adjust the part that has been placed inside the machine, then a dual stop signal is given to the machine.

The JSTD20 is equipped with a large over hand flange according to EN 574. These prevent unintended activation by a knee or elbow.

A two-hand device only protects the operator using it. Large machines operated by several operators can be equipped with one control for each operator.

To calculate the correct safety distance, which depends on the machine's stopping time including the safety controller's reaction time, the use of the ABB Jokab Safety SMART Stopping Analyzer is recommended.

## Highest Safety Level

Correct connection to an ABB Jokab Safety JSBR4 Safety Relay or Pluto Safety PLC ensures the highest level of safety with dual and supervised safety function and requires input activation of both operating push buttons within 0.5 seconds (two hand device type III C according to EN 574. If the emergency push button is installed it should be provided with two normally closed contacts and be connected to a separate safety relay, e.g. from the RT series or Pluto Safety PLC.



## Applications

- Presses
- Punching Machines
- Cutting Machines
- Fixtures

## Features

- Durable material
- With or without emergency stop push button
- Fulfills requirements of EN 574
- Highest safety level (category 4)

*Optional Floor Mount with or without Distance Ring*

## Regulations and Standards

The JSTD20 is designed and approved in accordance with appropriate standards. Examples of such are: EN 418, EN 574, EN 954-1/EN ISO 13849-1, EN 999, EN 60947-1 and EN 60947-5-1.

## Approvals



## JSTD20 Technical Data

Manufacturer	ABB AB/Jokab Safety, Sweden
Ordering information	see page 9:35
Weight	JSTD20: 6.4 Kg JSTS30: 20 Kg JSTS31: 23 Kg
Color	Black housing, Black pushbuttons, Black floor stand
Temperature	-10°C...+70°C (Operating) -20°C to +70°C (storage)
Safety level EN ISO 13849-1 EN 954-1	Upp till kat. 4/PL e Upp till kat. 4
Material	Housing: 3mm Steel Gasket: Rubber Pushbuttons: Plastic
Operating pushbuttons Diameter Operating force Operating distance Mechanical life	60 mm Approx. 9N 3.5±1mm 10 <sup>6</sup> operations
Emergency pushbutton (JSTD20B only) Diameter Operating force Mechanical life Contacts	40 mm 40N 3 x 10 <sup>5</sup> operations Mechanically separated contact blocks
Operating pushbuttons	1 NO + 1 NC
Emergency pushbuttons	2 x NC
Isolation voltage	690V rms
Contact resistance	20 mohm
Rated current	10A
Utilisation categories	AC 15 240V 3A DC 13 240V 0.27A
Cabling	screw clamp terminals, 1 or 2 wires with max. cross-section 2.5 mm <sup>2</sup>
Contact material	Silver alloy on brass

Protection class	IP 65
Conformity	EN 418, EN 574, EN 954-1, EN ISO 13849, EN 60947-1, EN 60947-5-1, EN 999

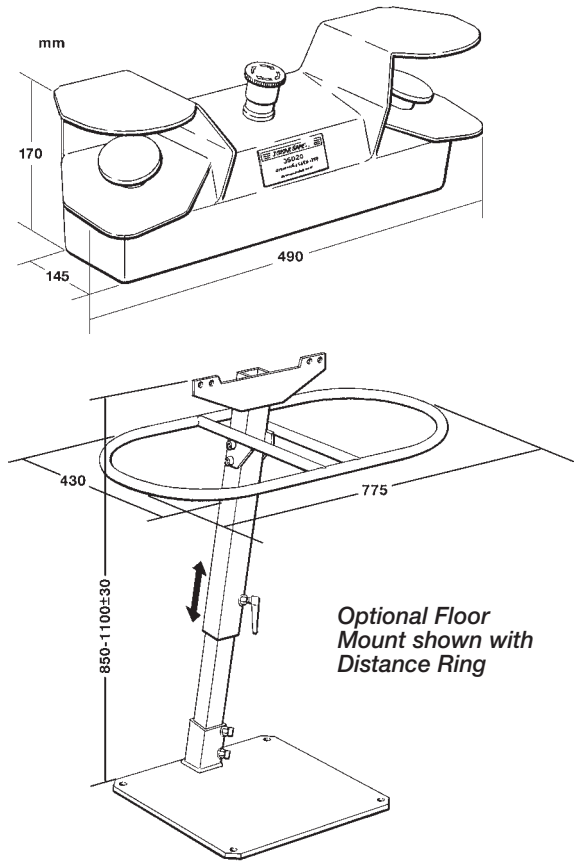

## JSTD20 Electrical Connection

The two-hand device is intended for use with ABB Jokab Safety's JSBR4 safety relay or Pluto Safety PLC to ensure the highest level of safety. The safety controller ensures that all contacts have returned to their deactivated positions before a new start is allowed. The safety relay also requires that all contacts are activated within 0.5 seconds. The safety controller gives a stop signal if one or both of the push buttons are released.

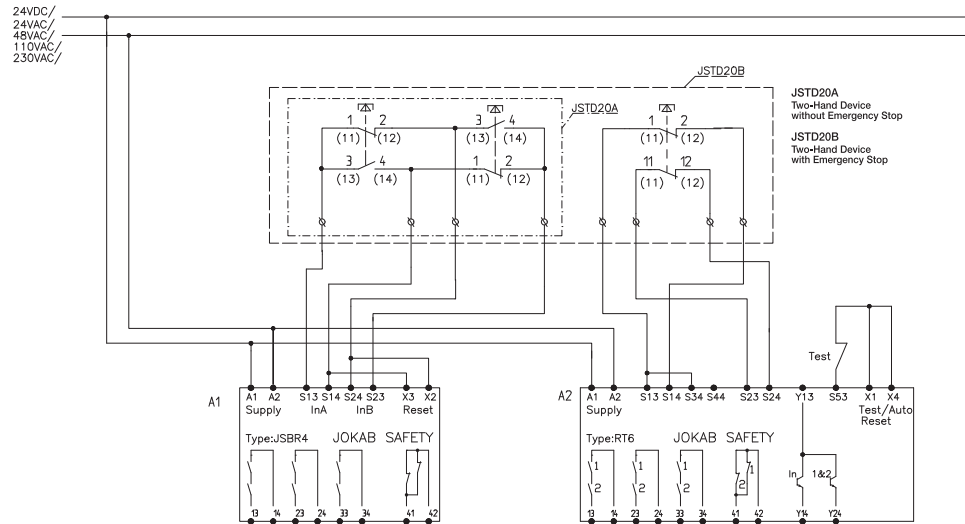

## Component List - Three-Position Enabling Device

Designation	Ordering Information	Description
JSNAHD4-4MR	2TLA850002R0800	No LEDs or buttons, large plate 5-pole micro receptacle
JSNAHD4S-5MR	2TLA850202R5800	No LEDs or buttons, small Plate 5-pole micro receptacle
JSNAHD4L-4MR	2TLA850002R7200	No buttons, with LEDs, large plate 5-pole micro receptacle
JSNAHD4LS-5MR	2TLA850202R6800	No buttons with LEDs, small plate 5-pole micro receptacle
JSNAHD4-4MP-10M	2TLA850002R0400	No LEDs or buttons, large plate 4-pole micro 10M single ended PVC cable
JSNAHD4-4MP-15M	2TLA850002R0500	No LEDs or buttons, large plate 4-pole micro 15M single ended PVC cable
JSNAHD4-4MP-20M	2TLA850202R6000	No LEDs or buttons, large plate 4-pole micro 20M single ended PVC cable
JSNAHD4S-4MP-10M	2TLA850002R8800	No LEDs or buttons, small plate 4-pole micro 10M single ended PVC cable
JSNAHD4S-4MP-15M	2TLA850202R6100	No LEDs or buttons, small plate 4-pole micro 15M single ended PVC cable
JSNAHD4S-4MP-20M	2TLA850002R8900	No LEDs or buttons, small plate 4-pole micro 20M single ended PVC cable
JSNAHD4L-4MP-10M,	2TLA850002R6900	No buttons with LEDs large plate 4-pole micro 10M single ended PVC cable
JSNAHD4L-4MP-15M	2TLA850002R7000	No buttons with LEDs, large plate 4-pole micro 15M single ended PVC cable
JSNAHD4L-4MP-20M	2TLA850202R2400	No buttons with LEDs, large plate 4-pole micro 20M single ended PVC cable
JSNAHD4LS-4MP-10M	2TLA850202R6900	No buttons with LEDs, small plate 4-pole micro 10M single ended PVC cable
JSNAHD4LS-4MP-15M	2TLA850202R2800	No buttons with LEDs, small plate 4-pole micro 15M single ended PVC cable
JSNAHD4LS-4MP-20M	2TLA850102R9700	No buttons with LEDs, small plate 4-pole micro 20M single ended PVC cable
JSNAHD4BL-8MR	2TLA850002R3400	LEDs with front and top auxiliary buttons, large plate 8-pole mini receptacle
JSNAHD4BLS-8MR	2TLA850002R4200	LEDs with front and top auxiliary buttons, small plate 8-pole mini receptacle
JSNAHD4BL-8MP-20FT	2TLA850202R6200	LEDs with front and top auxiliary buttons, large plate 8-pole mini receptacle, 20 ft PVC cable
JSNAHD4BL-8MP-30FT	2TLA850202R6300	LEDs with front and top auxiliary buttons, large plate 8-pole mini receptacle, 30 ft PVC cable
JSNAHD4BL-8MP-40FT	2TLA850202R6400	LEDs with front and top auxiliary buttons, large plate 8-pole mini receptacle, 40 ft PVC cable

## Component List - Three-Position Enabling Device

Designation	Ordering Information	Description
JSNAHD4BLS-8MP-20FT	2TLA850202R6500	LEDs with front and top auxiliary buttons, small plate 8-pole mini receptacle, 20 ft PVC cable
JSNAHD4BLS-8MP-30FT	2TLA850202R6600	LEDs with front and top auxiliary buttons, small plate 8-pole mini receptacle, 30 ft PVC cable
JSNAHD4BLS-8MP-40FT	2TLA850202R6700	LEDs with front and top auxiliary buttons, small plate 8-pole mini receptacle, 40 ft PVC cable
JSNAHD4BLE-8MR	2TLA850002R3700	LEDs with front and top auxiliary buttons, Eden bracket, 8-pole mini receptacle
JSNAHD4LE-8MR	2TLA850002R8200	No buttons with LEDs, Eden bracket, 8 pole mini receptacle
JSHD4H2A	2TLJ020002R0200	Three-position device for external panel assembly. <i>(Complete JSHD4 with standard options are available to order separately.)</i>
JSHD4S2	2TLJ020002R0700	Three-position device, ABB upgrading kit. <i>(Complete JSHD4 with standard options are available to order separately.)</i>
JSHD4H2	2TLJ020002R3100	Three-position devices for internal panel assembly. <i>(Complete JSHD4 with standard options are available to order separately.)</i>
JSHD2C Type E	2TLJ020001R1000	Three-position button. <i>(Complete JSHD4 with standard options are available to order separately.)</i>
JSHD2C Type K	2TLJ020001R1300	Three-position button. <i>(Complete JSHD4 with standard options are available to order separately.)</i>

## Component List - Pendant Holsters

Designation	Ordering Information	Description
JSNA-JSM-2A	2TLA850102R6300	Standard Pendant Holster with JSNY5As
JSNA-EDENPEN-HOL	2TLA850102R7800	Eden-style Pendant Holster JSHD4-1AA

## Component List - Receptacles

Designation	Ordering Information	Description
JSNA-5FR-2-1M	2TLA850102R4000	5-pole micro receptacle with 1M leads
JSNA-8PFR-3	2TLA850102R4500	8-pole mini receptacle with 3 ft leads JSHD4-1AC

## Component List - Shorting Plugs

Designation	Ordering Information	Description
JSNA-4PM-SP1	2TLA850102R3800	4-pole micro shorting plug 1-2-3-4
JSNA-8PM-SP1	2TLA850102R6100	8-pole mini shorting plug, pin 1-2-3-4 jumped JSHD4-2AB



## Component List - 8-Pole Mini Double Ended Cables

Designation	Ordering Information	Description
JSNA-8PMFEX-20	2TLA850102R5300	8-pole mini, double ended, male/female, 20 ft
JSNA-8PMFEX-30	2TLA850102R5400	8-pole mini, double ended, male/female, 30 ft
JSNA-8PMFEX-40	2TLA850102R5500	8-pole mini, double ended, male/female, 40 ft

## Component List - 8-Pole Mini Single Ended Cables

Designation	Ordering Information	Description
JSNA-8PFSE-20	2TLA850102R4800	8-pole mini, single ended, female, 20 ft
JSNA-8PFSE-30	2TLA850102R4900	8-pole mini, single ended, female, 30 ft
JSNA-8PFSE-40	2TLA850102R5000	8-pole mini, single ended, female, 40 ft

## Component List - Wall Brackets

Designation	Ordering Information	Description
JSM 54A	2TLJ020205R2800	Eden wall bracket

## Component List - Accessories and Spare Parts

Designation	Ordering Information	Description
JSNA-PCG.5B	2TLA850013R5300	Plastic cable gland with 1/2" NPT threads, cable OD range = 0.170" to 0.470". Locknut not included.
JSNA-1-50S	2TLA850013R2000	Metal locknut for 1/2" NPT threads.

## Component List - Pre-Assembled Three-Position Enabling Devices (European versions only)

Designation	Ordering Information	Description
JSHD4-1AA	2TLA019995R0000	Standard handle, no LEDs, no buttons, no cheat safe, cable gland
JSHD4-1AC	2TLA019995R0100	Standard handle, no LEDs, no buttons, no cheat safe, M12 5 pole male connector
JSHD4-2AB	2TLA019995R0200	Standard handle, LEDs, top and front buttons, no cheat safe, cannon connection
JSHD4-2AB-A	2TLA019995R0300	Standard handle, LEDs, top and front buttons, cheat safe, cannon connection
JSHD4-2AD	2TLA019995R0400	Standard handle, LEDs, top and front buttons, no cheat safe, M12 8 pole male connector
JSHD4-2AD-A	2TLA019995R0500	Standard handle, LEDs, top and front buttons, cheat safe, M12 8 pole male connector

## Component List - Pre-Assembled Three-Position Enabling Devices (European versions only)

Designation	Ordering Information	Description
JSHD4-2AF	2TLA019995R0600	Standard handle, LEDs, top and front buttons, no cheat safe, M12 4 pole male connector and 2 AS-i nodes for top and front buttons
JSHD4-2AF-A	2TLA019995R0700	Standard handle, LEDs, top and front buttons, cheat safe, M12 4 pole male connector and 2 AS-i nodes for top and front buttons
JSHD4-2AH	2TLA019995R0800	Standard handle, LEDs, top and front buttons, no cheat safe, cable gland and pcb with 10 screw connections
JSHD4-2AH-A	2TLA019995R0900	Standard handle, LEDs, top and front buttons, cheat safe, cable gland and pcb with 10 screw connections
JSHD4-3AB	2TLA019995R1200	Standard handle, LEDs, no buttons, no cheat safe, cannon connection
JSHD4-3AB-A	2TLA019995R1300	Standard handle, LEDs, no buttons, cheat safe, cannon connection
JSHD4-3AD	2TLA019995R1400	Standard handle, LEDs, no buttons, no cheat safe, M12 8-pole male connector
JSHD4-3AD-A	2TLA019995R1500	Standard handle, LEDs, no buttons, cheat safe, M12 8-pole male connector
JSHD4-3AE	2TLA019995R1600	Standard handle, LEDs, no buttons, no cheat safe, M12 8-pole male connector and emergency stop
JSHD4-3AF	2TLA019995R1700	Standard handle, LEDs, no buttons, no cheat safe, M12 4-pole male connector and 2 AS-i nodes for top and front buttons
JSHD4-3AF-A	2TLA019995R1800	Standard handle, LEDs, no buttons, cheat safe, M12 4-pole male connector and 2 AS-i nodes for top and front buttons
JSHD4-3AG	2TLA019995R1900	Standard handle, LEDs, no buttons, no cheat safe, M12 4-pole male connector and 2 AS-i nodes for top and front buttons
JSHD4-3AH	2TLA019995R2000	Standard handle, LEDs, no buttons, no cheat safe, cable gland and pcb with 10 screw connections
JSHD4-3AH-A	2TLA019995R2100	Standard handle, LEDs, no buttons, cheat safe, cable gland and pcb with 10 screw connections
JSHD4-4AB	2TLA019995R2400	Standard handle, LEDs, front button, no cheat safe, cannon connection
JSHD4-4AB-A	2TLA019995R2500	Standard handle, LEDs, front button, cheat safe, cannon connection
JSHD4-4AD	2TLA019995R2600	Standard handle, LEDs, front button, no cheat safe, M12 8-pole male connector
JSHD4-4AD-A	2TLA019995R2700	Standard handle, LEDs, front button, cheat safe, M12 8-pole male connector
JSHD4-4AF	2TLA019995R2800	Standard handle, LEDs, front button, no cheat safe, M12 4-pole male connector and 2 AS-i nodes for top and front buttons
JSHD4-4AF-A	2TLA019995R2900	Standard handle, LEDs, front button, cheat safe, M12 4-pole male connector and 2 AS-i nodes for top and front buttons
JSHD4-4AH	2TLA019995R3000	Standard handle, LEDs, front button, no cheat safe, cable gland and pcb with 10 screw connections

## Component List - Pre-Assembled Three-Position Enabling Devices (European versions only)

Designation	Ordering Information	Description
JSHD4-4AH-A	2TLA019995R3100	Standard handle, LEDs, front button, cheat safe, cable gland and pcb with 10 screw connections
JSHD4-5AB	2TLA019995R3400	Standard handle, LEDs, top button, no cheat safe, cannon connection
JSHD4-5AB-A	2TLA019995R3500	Standard handle, LEDs, top button, cheat safe, cannon connection
JSHD4-5AD	2TLA019995R3600	Standard handle, LEDs, top button, no cheat safe, M12 8-pole male connector
JSHD4-5AD-A	2TLA019995R3700	Standard handle, LEDs, top button, cheat safe, M12 8-pole male connector
JSHD4-5AF	2TLA019995R3800	Standard handle, LEDs, top button, no cheat safe, M12 4-pole male connector and 2 AS-i nodes for top and front buttons
JSHD4-5AF-A	2TLA019995R3900	Standard handle, LEDs, top button, cheat safe, M12 4-pole male connector and 2 AS-i nodes for top and front buttons
JSHD4-5AH	2TLA019995R4000	Standard handle, LEDs, top button, no cheat safe, cable gland and pcb with 10 screw connections
JSHD4-5AH-A	2TLA019995R4100	Standard handle, LEDs, top button, cheat safe, cable gland and pcb with 10 screw connections





## Component List - Accessories for Pre-Assembled Enabling Devices

Designation	Ordering Information	Description
M12-C01	2TLJ020055R1000	M12 5-pole female connector, straight
M12-C03	2TLJ020055R1600	M12 8-pole female connector, straight
JSHK0	2TLJ020003R0300	12-pole connector for JSHD4
C5	2TLJ020057R0000	Cable with 5 conductors; 5x0.34 cut to length
M12-C101	2TLJ020056R1000	Cable with 5 connectors; 10M and connector
M12-C201	2TLJ020056R1400	Cable with 5 connectors; 20M and connector
C8	2TLJ020057R1000	Cable with 8 conductors; 8x0.34 cut to length
M12-C103	2TLJ020056R4000	Cable with 8 connectors; 10M cable and connector
M12-C203	2TLJ020056R4100	Cable with 8 connectors; 20M and connector
HKC12	2TLA020003R5500	Cable with 12 conductors; 12x0.25 cut to length
HK5	2TLA020003R4700	Cable with 12 connectors; 5M and connector
HK10	2TLA020003R4800	Cable with 12 connectors; 10M and connector
HK20	2TLA020003R4900	Cable with 12 connectors; 20M and connector
JSHK16S4	2TLA020003R5000	Spiral cable with 12 connectors; 1.6M and connector
JSHK20S4	2TLA020003R5100	Spiral cable with 12 connectors; 2.0M and connector



## Component List - Accessories for Pre-Assembled Enabling Devices

Designation	Ordering Information	Description
JSHK32S4	2TLA020003R5200	Spiral cable with 12 connectors; 3.2M and connector
JSHK40S4	2TLA020003R3500	Spiral cable with 12 connectors; 4.0M and connector
JSHK3604	2TLA020003R3600	Spiral cable with 12 connectors; 6.0M and connector
JSHK80S4	2TLA020003R5300	Spiral cable with 12 connectors; 8.0M and connector
HK-T2	2TLA020003R5400	Cable drum and connector
JSM55	2TLJ040005R0500	Wall bracket for three-position device
JSM5B	2TLJ040005R0700	Wall bracket for 2 JSNY5 (ordered separately)
JSHD4	2TLA020200R4600	Protection coat

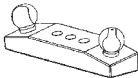
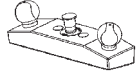
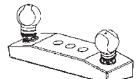

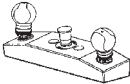
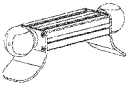
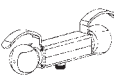

## Component List - Safeball

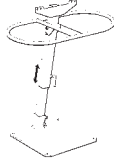
Designation	Ordering Information	Description
JSTD1-A	 2TLJ020007R3000	Safeball device with 1NO & 1NC independent switches for dual channel switching as a one hand device, maximum load of 30VDC - 2A resistive. Ergonomic design with several grip possibilities, low activation force (approx. 2N) and flexible mounting options. Provides highest level of safety for use in two hand control applications when using two Safeballs in conjunction with a JSBR4 safety relay or Pluto Safety PLC. IP67 protection degree, plastic body, 2 meter molded cable.
JSTD1-B	 2TLJ020007R3100	Safeball device with 1NO & 1NC independent switches for dual channel switching as a one hand device, maximum load of 30VDC - 2A resistive. Ergonomic design with several grip possibilities, low activation force (approx. 2N) and flexible mounting options. Provides highest level of safety for use in two hand control applications when using two Safeballs in conjunction with a JSBR4 safety relay or Pluto Safety PLC. IP67 protection degree, plastic body, 0.25m wires x 4 for direct connection into an enclosure.
JSTD1-C	 2TLJ020007R3200	Safeball device with 1NO & 1NC independent switches for dual channel switching as a one hand device, maximum load of 30VDC - 2A resistive. Ergonomic design with several grip possibilities, low activation force (approx. 2N) and flexible mounting options. Provides highest level of safety for use in two hand control applications when using two Safeballs in conjunction with a JSBR4 safety relay or Pluto Safety PLC. IP67 protection degree, plastic body, 10 meter molded cable.
JSTD1-E	 2TLJ020007R3400	Safeball device with 2 NO independent switches for dual channel switching as a one hand device, maximum load of 30VDC - 2A resistive. Ergonomic design with several grip possibilities, low activation force (approx. 2N) and flexible mounting options. Provides highest level of safety for use in two hand control applications when using two Safeballs in conjunction with a JSBR4 safety relay or Pluto Safety PLC. IP67 protection degree, plastic body, 0.25m wires x 4 for direct connection into an enclosure.
JSTD25A	 2TLJ020007R5000	Safeball each with 1NO & 1NC independent switches, maximum load of 30VDC - 2A resistive. Ergonomic design with several grip possibilities and low activation force (approx. 2N). Buttons are mounted in black painted steel housing designed for two-hand applications. Terminal blocks within housing for connection to buttons. Highest level of safety can be achieved when using in conjunction with a JSBR4 safety relay or Pluto Safety PLC.
JSTD25B	 2TLJ020007R5100	2 hand device with JSTD1B Safeballs and e-stop button. Safeball each with 1NO & 1NC independent switches, maximum load of 30VDC - 2A resistive. Ergonomic design with several grip possibilities and low activation force (approx. 2N). E-stop button diameter is 40mm, 40N operating force, 2 NC positive opening contacts, rated current of 10A. Buttons are mounted in black painted steel housing designed for two-hand applications. Terminal blocks within housing for connection to buttons. Highest level of safety can be achieved when using in conjunction with a JSBR4 safety relay for two-hand buttons and RT9/RT6 safety relay for e-stop button or a Pluto Safety PLC.
JSTD25D	 2TLJ020007R5300	2 hand device with JSTD1B Safeballs and JSMC5 ball and socket mounting supports. Safeball each with 1NO & 1NC independent switches, maximum load of 30VDC - 2A resistive. Ergonomic design with several grip possibilities and low activation force (approx. 2N). Buttons are mounted in black painted steel housing designed for two-hand applications. Terminal blocks within housing for connection to buttons. Highest level of safety can be achieved when using in conjunction with a JSBR4 safety relay or Pluto Safety PLC.

## Component List - Safeball

Designation	Ordering Information	Description
<b>JSTD25E</b> 	2TLJ020007R5400	2 hand device with JSTD1B safeballs and JSMC5 ball and socket mounting supports and e-stop button. Safeball each with 1NO & 1NC independent switches, maximum load of 30VDC - 2A resistive. Ergonomic design with several grip possibilities and low activation force (approx. 2N). E-stop button diameter is 40mm, 40N operating force, 2 NC positive opening contacts, rated current of 10A. Buttons are mounted in black painted steel housing designed for two-hand applications. Terminal blocks within housing for connection to buttons. Highest level of safety can be achieved when using in conjunction with a JSBR4 safety relay for two-hand buttons and RT9/RT6 safety relay for e-stop button or a Pluto Safety PLC.
<b>JSTD25F</b> 	2TLJ020007R6000	2 hand device with JSTD1B Safeballs. Safeballs each have 1NO & 1NC independent switches, maximum load of 30VDC - 2A resistive. Ergonomic design with several grip possibilities and low activation force (approx. 2N). Buttons are side mounted 44x88 extruded aluminum profile designed for two-hand applications. Pre-wired to a M12 4 pin connector with protective flanges of the safeballs. Highest level of safety can be achieved when used in conjunction with a JSBR4 safetyrelay or Pluto Safety PLC.
	2TLJ020007R6400	Protective plates for Safeball (kit) including fasteners
<b>JSTD25G</b>	2TLJ020007R6200	2 hand device with JSTD1B Safeballs. Safeballs each have 1NO & 1NC independent switches, maximum load of 30VDC - 2A resistive. Ergonomic design with several grip possibilities and low activation force (approx. 2N). Buttons are side mounted 44x88 extruded aluminum profile designed for two-hand applications. Pre-wired to molded yellow cable with protective flanges of the safeballs. Integrated Smile illuminated E-Stop. Highest level of safety can be achieved when used in conjunction with a JSBR4 safety relay for two-hand buttons and RT9/RT6 safety relay for e-stop button or a Pluto Safety PLC.
<b>JSTD25H</b>	2TLJ020007R6300	2 hand device with JSTD1B Safeballs. Safeballs each have 1NO & 1NC independent switches, maximum load of 30VDC - 2A resistive. Ergonomic design with several grip possibilities and low activation force (approx. 2N). Buttons are side mounted 44x88 extruded aluminum profile designed for two-hand applications. Pre-wired to a M12 8 pole connector with protective flanges of the safeballs. Highest level of safety can be achieved when used in conjunction with a JSBR4 safety relay or Pluto Safety PLC.
<b>JSTD25P-1</b> 	2TLJ020007R6500	2 hand device with JSTD1B Safeballs. Safeballs each have 1NO & 1NC independent switches, maximum load of 30VDC - 2A resistive. Ergonomic design with several grip possibilities and low activation force (approx. 2N). Buttons are side mounted on black aluminum profile designed for two-hand applications. Pre-wired to a 9 pin Zylin connector with dual protective flanges of the safeballs. Integrated Eva inside housing for Eden sensor holster JSMC14. Highest level of safety can be achieved when used in conjunction with a JSBR4 safety relay or Pluto Safety PLC.
<b>JSTS30</b> 	2TLJ020007R4000	Floor mount stand for JSTD20/25 two-hand devices. Black painted steel with adjustable height lever.
<b>JSTS31</b> 	2TLJ020007R4100	Floor mount stand for JSTD20/25 two-hand devices. Black painted steel with adjustable height lever and distance ring.

## Component List - Safeball

Designation	Ordering Information	Description
JSM C5 	2TLJ020007R0900	Flexible mount for mounting the Safeball to Enclosures. Extrusion or table tops. Includes all hardware.
JSNA-SB Adapter 	2TLA850004R0300	Safeball adapter for integration into 22mm or 30mm punched enclosures. Two are required for a Safeball pair.
JSTS32	2TLJ020007R4200	Distance ring for JSTS30 floor mount stand 2 hand device with JSTD1B Safeballs.
JSTKO-A	2TLJ020007R6600	Connector for JSTD25P-1
JSTK40S	2TLJ020007R6700	4 m long spiral cable for JSTD25P-1
JSTK80S	2TLJ020007R6800	8 m long spiral cable for JSTD25P-1
JSMC14	2TLJ020007R8000	Universal suspension shelf for JSTD25P-1
JSTD20A 	2TLJ020007R2000	2 hand device with conventional operating buttons. Operating push-buttons are 60mm in diameter, black, 9N operating force, 1 NO + 1 NC contacts, rated current of 10A. Buttons are mounted in black painted steel housing designed for two-hand applications. Ingress protection IP65. Terminal blocks within housing for connection to buttons. Highest level of safety can be achieved when using in conjunction with a JSBR4 safety relay for two-hand buttons or a Pluto Safety PLC.
JSTD20B 	2TLJ020007R2100	2 hand device with conventional operating buttons and e-stop button. Operating push buttons are 60mm in diameter, black, 9N operating force, 1 NO + 1 NC contacts, rated current of 10A. E-stop button diameter is 40mm, 40N operating force, 2 NC positive opening contacts, rated current of 10A. Buttons are mounted in black painted steel housing designed for two-hand applications. Ingress protection IP65. Terminal blocks within housing for connection to buttons. Highest level of safety can be achieved when using in conjunction with a JSBR4 safety relay for two-hand buttons and RT9/RT6 safety relay for e-stop button or a Pluto Safety PLC.
JSTD20C 	2TLJ020007R2200	JSTD20 housing only, for two-hand device. Steel and black painted. Accepts up to 60mm operating buttons for two-hand device and 40mm e-stop button.

This document and any attachments may include suggested specifications, drawings, schematics and similar materials from ABB Inc. Use of such information and/or documentation by the recipient is subject to and conditioned upon your acceptance of the terms of the General Document Disclaimer which can be found at [www.jokabsafetyna.com](http://www.jokabsafetyna.com). Your acceptance of the terms of such General Document Disclaimer is conclusively presumed unless you notify ABB in writing of your disagreement with the terms of such Disclaimer immediately upon receipt of this document and you return to ABB all specifications, drawings, schematics and similar materials provided to you by ABB.

Notes





# Emergency Stops

Shut down all machine functions!  
 Protect machine during breakdown!  
 Meet emergency stop regulations!

Why should I use an Emergency Stop? .....	9:2
INCA1/INCA1 Tina Emergency Stop for Enclosure Installation .....	9:3
Technical Data.....	9:4
Smile Emergency Stop with LED .....	9:5
Connection Examples and Technical Data .....	9:6
Smile Tina Emergency Stop with LED .....	9:9
Connection Examples and Technical Data .....	9:10
Smile AS-i Emergency Stop with Indication .....	9:13
Technical Data.....	9:14
Stop-Line Emergency Stop Grab Wire Safety Switch.....	9:15
Technical Data and Mounting .....	9:16
Contact Adjustment and Electrical Connection .....	9:17
Smile and Inca Safety Stops.....	9:18
Smile 11R Reset Button.....	9:18
Component List and Ordering Information .....	9:19



## Why should I use an Emergency Stop?

...to be able to stop a machine during a machine break-down or if someone is in danger!

### How do I recognize an E-Stop?

All E-Stops which comply with the relevant standards for marking are red with a yellow background. An emergency stop grab wire should be red for high visibility.

### How should an E-Stop stop the machine?

An E-Stop should stop the machine as quickly as possible. To obtain a quick stop, one either removes the power directly or one lets a frequency converter 'run down' and afterwards —after a little delay— remove the power. An E-Stop should not create other hazards. Therefore a risk analysis must be made for the E-stop to be correctly connected.

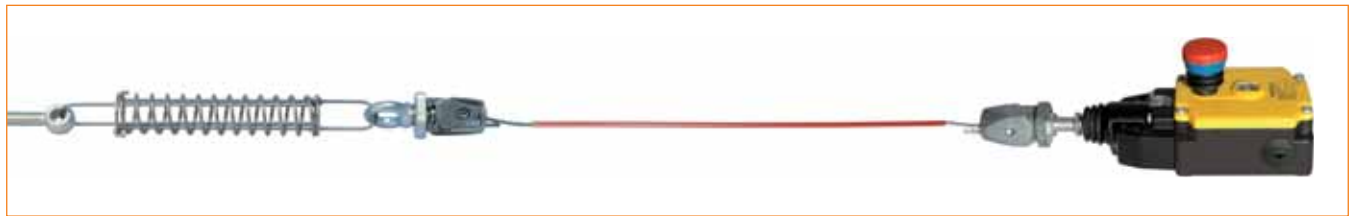

## Requirements for E-stops are stated in these standards and regulations:

### 2006/42/EC The Machinery Directive

Clause 1.2.4.3 in Annex 1 gives requirements for the emergency stop function for new machines. See also clause 1.2.2 Control devices.

### Council Directive 89/655/EEC

*(with amendments) concerning the minimum safety and health requirements for the use of work equipment by workers at work*

Clause 2.4 gives the requirements for the emergency stop function for older machines. See also clause 2.1.

### EN ISO 13850 Safety of machinery

#### *Emergency stop — Principles for design*

A harmonized standard that gives technical specifications for the requirements in the Machinery Directive. Could also be used for older machinery.

### EN 60204-1 Safety of Machinery

#### *Electrical equipment of machines – Part 1: General requirements.*

Harmonized standard that gives requirements for the electrical equipment of machinery including the emergency stop actuator/function. See clauses 9.2.2 and 9.2.5.4.2.

# INCA1/INCA1 Tina Emergency Stop for Enclosure Installation

INCA1 is an emergency stop device designed for installation in a 22.5mm opening in an enclosure. There are two versions—the INCA1 Tina, with electronic adaptation for connection to a dynamic safety circuit and connection to Vital and Pluto units—and INCA1, that contains only contacts, for use in dual channel solutions.

There is an LED in the emergency stop button, which shows the current status:

- Green = all OK
- Red = this emergency stop has been pressed
- Unlit (INCA1) or flashing red/green (INCA1 Tina) = a protective device earlier in the circuit has been pressed in.

## Regulations and Standards

The INCA1/INCA 1 Tina is designed and approved in accordance with appropriate standards. Examples of such are: EN ISO 13850:2006, EN ISO 13850, EN 60204, EN 60947-5-1 and EN 60947-5-5.



## Features

- Installation in 22.5mm opening
- Only 53mm installation depth in an apparatus enclosure
- LED information in the button and an electrical information output (IP65)
- Available with a black button for an ordinary push button line stop

## Approvals

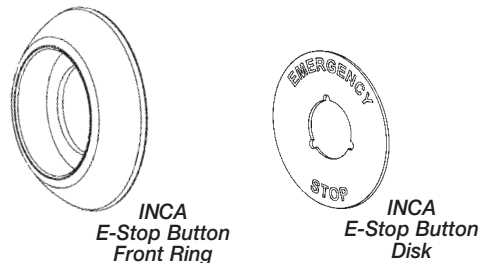
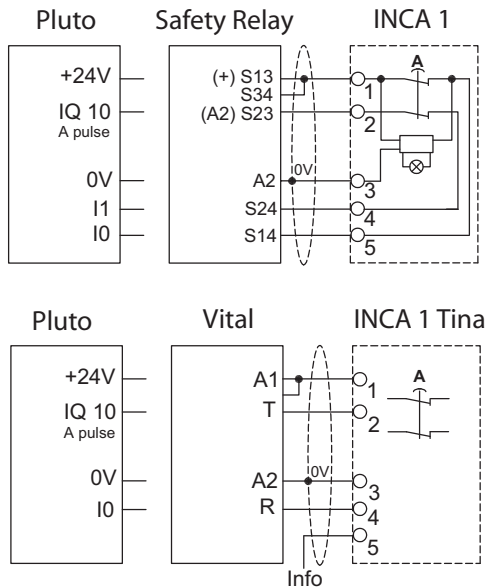
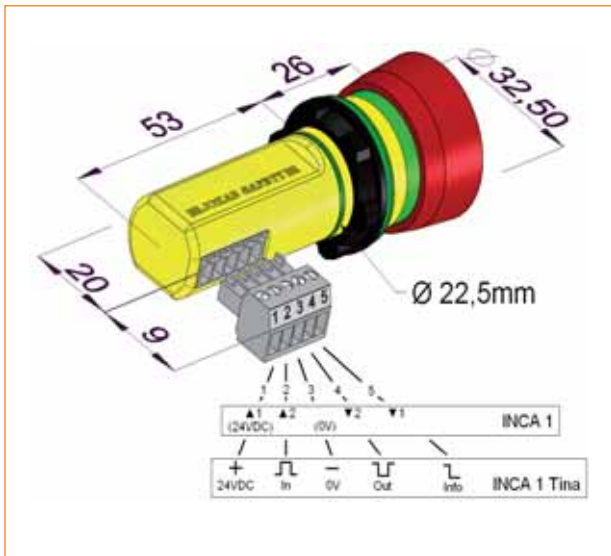

## INCA 1/INCA 1 Tina Technical Data

Manufacturer	ABB AB/Jokab Safety, Sweden
Ordering information	see page 10:19
Impact resistance (half sinusoidal)	Max. 150m/s <sup>2</sup> , pulse width 11 ms, 3-axis, acc. to EN IEC 60068-2-27
Vibration resistance (sinusoidal)	Max. 50 m/s <sup>2</sup> at 10 Hz...500 Hz, 10 cycles, 3 axis, acc. to EN IEC 60068-2-6
Climate resistance Damp heat, cyclical	96 hours, +25 °C / 97%, +55 °C / 93 % relative humidity, as per EN IEC 60068-2-30
Damp heat, sustained	56 days, +40 °C / 93 % relative humidity, as per EN IEC 60068-2-78
Dry heat	96 hours, +70 °C, as per EN IEC 60068-2-2
Cooling	96 hours, -40 °C, as per EN IEC 60068-2-1
Salt mist	96 hours, +35 °C in a chemical solution with NaCl as per EN IEC 60068-2-11
Level of safety Cat. 4/PL e Category 4 SIL 3 SIL 3	EN ISO 13849-1 EN 954-1 EN 62061 IEC/EN 61508-1...7
PFH <sub>d</sub> INCA 1 INCA 1 Tina	PFH <sub>d</sub> : 1.60×10 <sup>-10</sup> PFH <sub>d</sub> : 4.66×10 <sup>-9</sup>
Color	Yellow, red and black
Weight	Approx. 45 grams
Size	See drawing
Material	Polyamide PA66, Macromelt, Polybutylenterephthalate PBT UL 94 V0
Temperature	-10°C to +55°C (operation), -30°C to +70°C (storage)
Enclosure classification	Print: IP 65, Connector: IP20
Installation	22.5 mm
Emergency stop LEDs	
INCA 1 Green Not lit	Safety device OK A unit earlier in the circuit is affected
Red	This emergency stop has been pressed
INCA 1 Tina Green Flashing	Safety device OK, safety circuit OK Safety device OK, safety circuit previously broken
Red	This button is pressed in, and the safety circuit is broken

Operating voltage (LED) INCA 1 INCA 1 Tina	24 VDC 24VDC +15% -25%
Current consumption (LED) INCA 1 INCA 1 Tina	15 mA 47 mA
Emergency stop button Operating force	22 ± 4 N
Operating movement	Approx. 4 mm to locked position
Contact material	Gold-plated silver alloy
Minimum current INCA 1 INCA 1 Tina	10 mA, 10 VDC/10 VAC —
Maximum current INCA 1 INCA 1 Tina	2 A 24 VDC, 1A 125 VAC —
Mechanical life	> 50,000 operations
Standards	EN 60204, EN 60947-5-1 & -5 EN ISO 13850
Accessories Front ring yellow for INCA Emergency stop sign S D F, 22.5mm Emergency stop sign E FT, 22.5mm	2TLJ030054R0400 2TLJ030054R0500 2TLJ030054R0600
Conformity	2006/42/EG EN 954-1, EN ISO 13849-1 EN 62061, EN 60204-1 EN 61496-1, IEC 60664-1 EN 61000-6-2, EN 61000-6-4 EN 60947-5-1, EN 1088

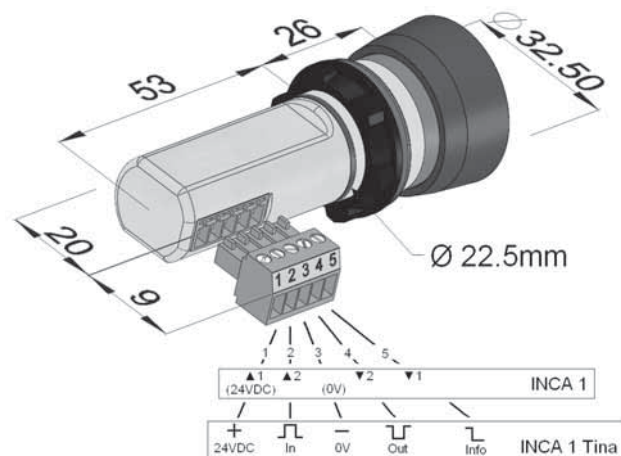

# Smile Emergency Stop with LED

## Small and Cost Effective

Smile is an emergency stop button designed to be installed in areas with space limitations. This device is much like a common quick disconnect proximity switch which is engineered into the design of a machine. The connector allows for the use of premolded cables, eliminating labor and improper wiring. With M12 connection/s and centralized mounting holes, Smile is very easy to install, especially on aluminum extrusions.

Smile is available for E-Stops in both dynamic and static safety circuits—i.e. for interfacing to Vital/Pluto, Safety Relays or Safety PLCs using dual channel technology. Each version is available with either one or two M12 connections. LEDs in the top of the Smile E-stop unit show the actual status:

- Green = protection is OK
- Red = this E-Stop has been pressed
- OFF = an E-Stop earlier in the circuit has been pressed

### Regulations and Standards

The Smile Emergency Stop is designed and approved in accordance with appropriate standards. Examples of such are: EN ISO 13850, EN 60204, EN 60947-5-1 and EN 60947-5-5.

### 2 Different Variations of Smile Emergency Stops

**Smile 11EA** has a 5-pole M12 connector on one end of the unit.

**Smile 12EA** has two 5-pole M12 connectors, one on each end of the unit.

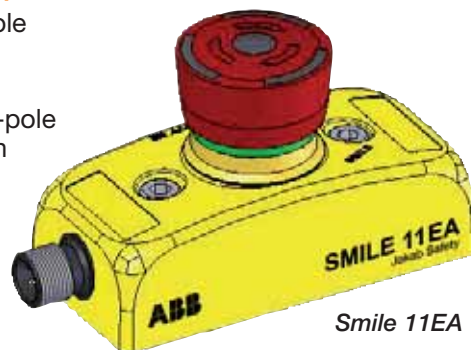

Smile 11EA



### Applications

- To stop a machine or a process

### Features

- Emergency push button up to Category 4 PL e according to EN ISO 13849-1
- LED indication at every E-Stop
- Robust construction
- IP65

### Approvals

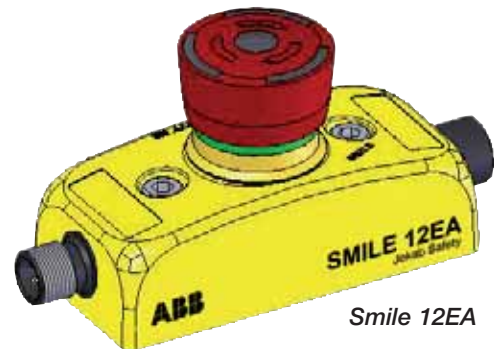

Smile 12EA

## Smile Connection Examples

**Smile 11EA** can be connected to either a Safety Relay or Safety PLC using dual channel technology. Single channel example with LED indication. Safety category 1. Connection via an M12 connector.

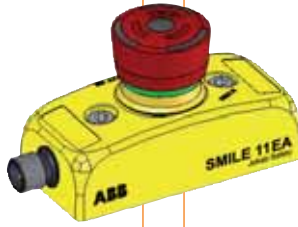
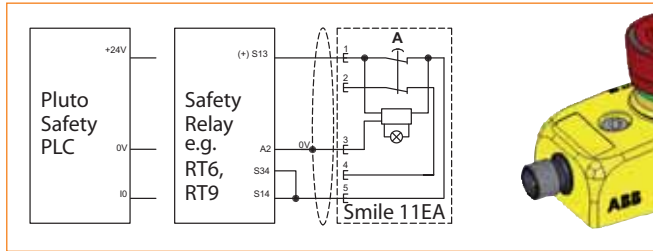

**Smile 11EA** can be connected to either a Safety Relay or Safety PLC using dual channel technology. Dual channel example with LED indication. Safety circuit category 4. Connection via an M12 connector.

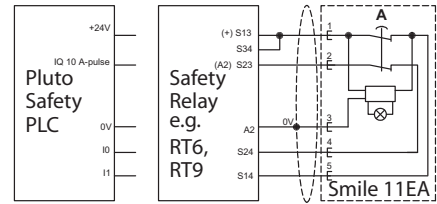

**Smile 12EA** can be connected to either a Safety Relay or Safety PLC using dual channel technology. Single channel example with LED indication. Safety category 1. Connection via an M12 connector, plus a termination connector.

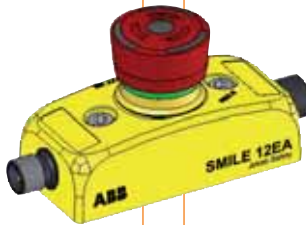
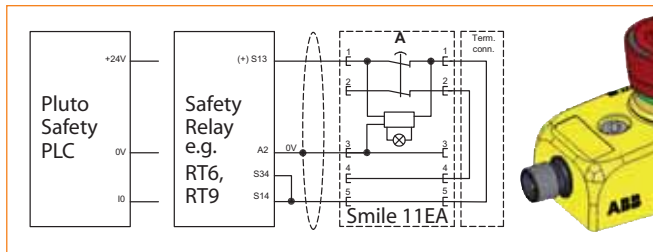

**Smile 12EA** can be connected to either a Safety Relay or Safety PLC using dual channel technology. Dual channel example with LED indication. Safety circuit category 4. Connection via an M12 connector, plus a termination connector.

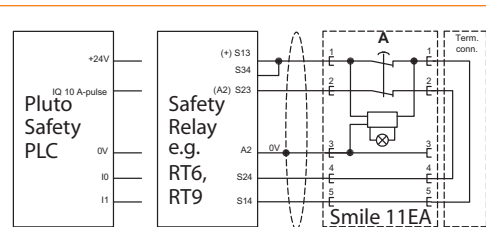

**Smile 12EA** can be connected to either a Safety Relay or Safety PLC using dual channel technology. Dual channel serial connection example with LED indication. Safety circuit category 3. Connection via

M12 connectors. Note that there is no termination connector for the Smile 12EA (see C on drawing), this unit being connected back to the Pluto/Safety Relay via a separate cable.

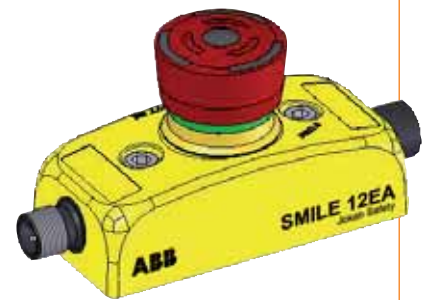
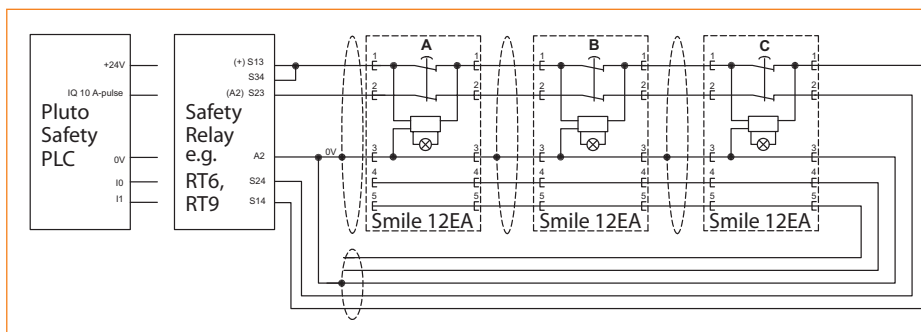

## Smile Connection Examples

**Smile 12EA and 11EA** can be connected to either a Safety Relay or Safety PLC using dual channel technology. Dual channel example with LED indication. Safety circuit category 3. Connection via M12

connectors. Note that there is no termination connector as the Smile 11EA (see C on drawing) completes the circuit without the need for a termination connector or return cable.

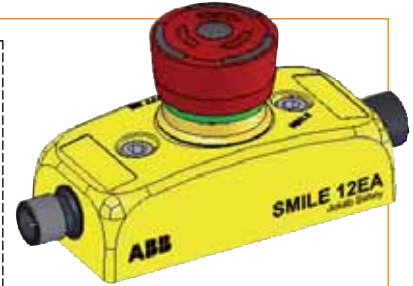
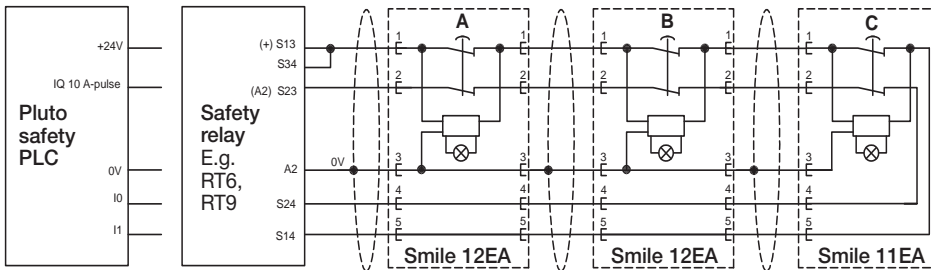

E-Stop Button Status				LED Indication		
A	B	C	↔	A	B	C
R	R	R	↔	G	G	G
R	R	D	↔	G	G	Rd
R	D	R	↔	G	Rd	B
R	D	D	↔	G	Rd	B
D	R	R	↔	Rd	B	B
D	R	D	↔	Rd	B	B
D	D	R	↔	Rd	B	B
D	D	D	↔	Rd	B	B

The table at the left shows the LED indication status of the E-Stop buttons from the example shown above.

- A = Smile 12EA
- B = Smile 12EA
- C = Smile 11EA
- R = Released
- D = Depressed
- G = Green light from the top of the button
- Rd = Red light from the top of the button
- B = Blank, no light



Termination device JST2

**Smile 11EA/12EA** are like any other emergency stops when 0V to the LED indication is not connected. This means that any suitable Safety PLC or Safety Relay can be used. If the LED indication is used, the

voltage between Pin 1 (+) and Pin 3 (-) should be between 19.2 and 28.8 VDC. The following examples show connections to Safety PLC and Safety Relay.

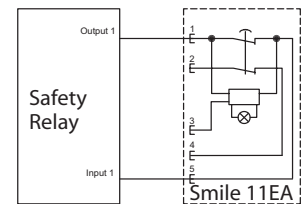
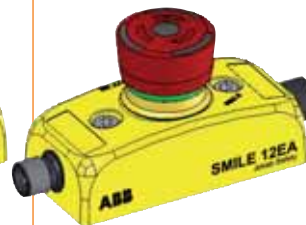
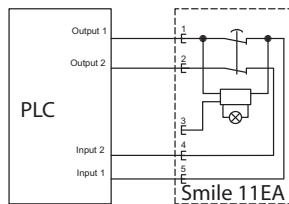

## Smile Technical Data

Manufacturer	ABB AB/Jokab Safety, Sweden
Ordering information	see page 10:19
Impact resistance (half sinusoidal)	max. 150 m/s <sup>2</sup> , pulse width 11 ms, 3-axis, as per EN IEC 60068-2-27
Vibration resistance (sinusoidal)	max. 50 m/s <sup>2</sup> at 10 Hz, 10 cycles, 3-axis, as per EN IEC 60068-2-6
Climate resistance Damp heat, cyclical	96 hours, +25 °C / 97%, +55 °C / 93% relative humidity, as per EN IEC 60068-2-30
Damp heat, sustained	56 days, +40 °C / 93% relative humidity, as per EN IEC 60068-2-78
Dry heat	96 hours, +70 °C, as per EN IEC 60068-2-2
Cooling	96 hours, -40 °C, as per EN IEC 60068-2-1
Salt mist	96 hours, +35 °C in a chemical solution with NaCl as per EN IEC 60068-2-11
Level of safety IEC/EN 61508-1...7	SIL 3
PFH <sub>d</sub>	1.60E-10
Color	Yellow, red and black
Weight	Approx. 65 grams
Size	Length: 84 mm + M12 contact(s) (12.5 mm each) Width: 40 mm Height: 52 mm
Material	Polyamide PA66, Macromelt, Polybutylenterephthalate PBT, Polypropylene PP, UL 94 V0
Ambient temperature	-10°C to +55°C (operation), -30°C to +70°C (stock)
Protection class	IP 65
Mounting	Two M5 recessed hexagon head screws, L ≥25 mm Hole cc: 44 mm

LED on E-Stop Green	Safety device ok, Safety circuit closed
Off	Safety circuit broken (When an E-Stop is depressed all following units in the circuit lose the LED function)
Red	Safety device actuator depressed and Safety circuit broken
Input voltage (LED)	17-27 VDC ripple ±10% (LED supply voltage)
Current consumption (LED)	15 mA
E-Stop button Actuating force	22 ± 4 N
Actuator travel	Approx. 4 mm to latch
Material, contacts	Silver alloy gold plated
Min current	10 mA 10 VDC/ 10 VAC
Max current	2 A 24 VDC, 1 A 125 VAC
Mechanical life	> 50,000 operations
Accessories Emergency stop button S D F, 32.5mm	2TLJ030054R0700
Emergency stop button E F T, 32.5mm	2TLJ030054R0800
Conformity	EN ISO 13850, EN 60204 EN 60947-5-1 & -5

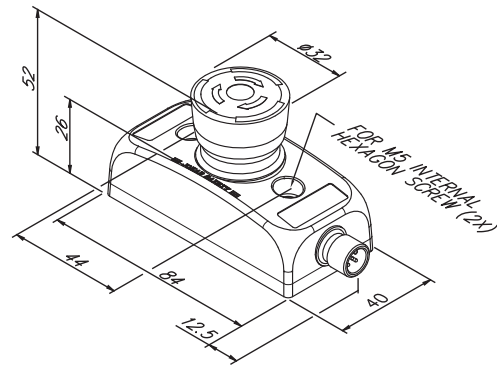

## Smile Connection Examples

### Smile 11EA

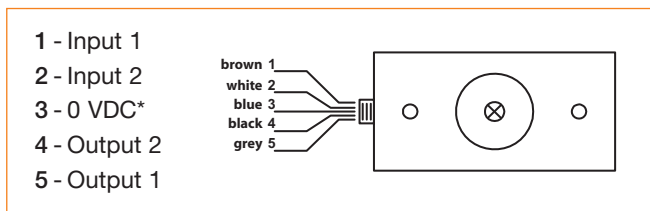

\*Note: 3 - 0 VDC is to be connected only if LED indication is required.

### Smile 12EA

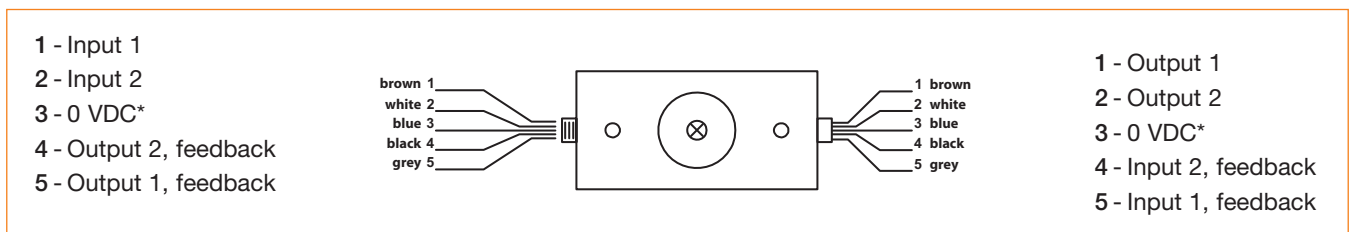



# Smile Tina Emergency Stop with LED

## Small and Cost Effective

Smile is an emergency stop button designed to be installed in areas with space limitations. This device is much like a common quick disconnect proximity switch which is engineered into the design of a machine. The connector allows for the use of premolded cables, eliminating labor and improper wiring. With M12 connection/s or cable and centralized mounting holes, Smile is very easy to install, especially on aluminum extrusions.

Smile is available for E-Stops in both dynamic and static safety circuits—i.e. for interfacing to Vital/Pluto, Safety Relays or Safety PLCs using dual channel technology. Each version is available with either one or two M12 connections or cable. Two M12 connectors are used to enable the connection of E-Stops in series, which is often used with dynamic safety circuits, fulfilling safety category 4. In the top of the Smile E-Stop unit LEDs show the actual status:

- Green = protection is OK
- Red = this E-Stop has been pressed
- Flashing Red/Green = an E-Stop earlier in the circuit has been pressed

### Regulations and Standards

The Smile Emergency Stop is designed and approved in accordance with appropriate standards. Examples of such are: EN ISO 13850:2006, EN ISO 13850, EN 60204, EN 60947-5-1 and EN 60947-5-5.

### 2 Different Variations of Smile Tina Emergency Stops

Smile 11EA Tina has a 5-pole M12 connector on one end of the unit.

Smile 12EA Tina has two 5-pole M12 connectors, one on each end of the unit for serial connecting.

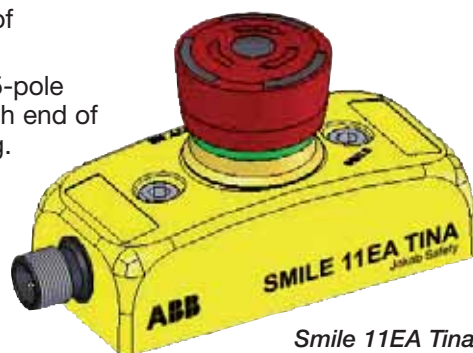

Smile 11EA Tina



### Applications

- To stop a machine or a process

### Features

- Emergency push button up to Category 4 PL e according to EN ISO 13849-1
- Light beam, E-Stop and Eden in the same safety circuit connected to Vital or Pluto enables safety Category 4 according to EN ISO 13849-1
- LED indication at every E-Stop
- Robust construction
- Info-signal from each E-Stop
- IP65

### Approvals

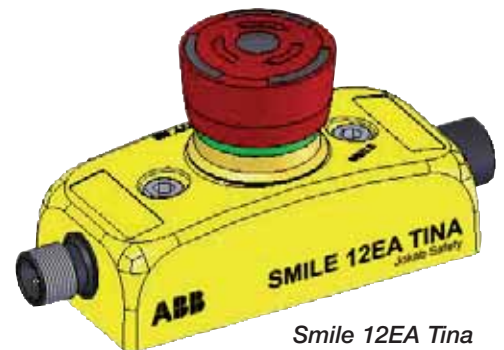

Smile 12EA Tina

## Smile Tina Connection Examples

**Smile 11EA Tina** can be connected to either Pluto or Vital system. Safety circuit category 4 with LED indication/information. Connection via M12 connec-

tors. The circuit below shows three Smile 11EA Tina units connected in series via connection terminals in the electrical cabinet.

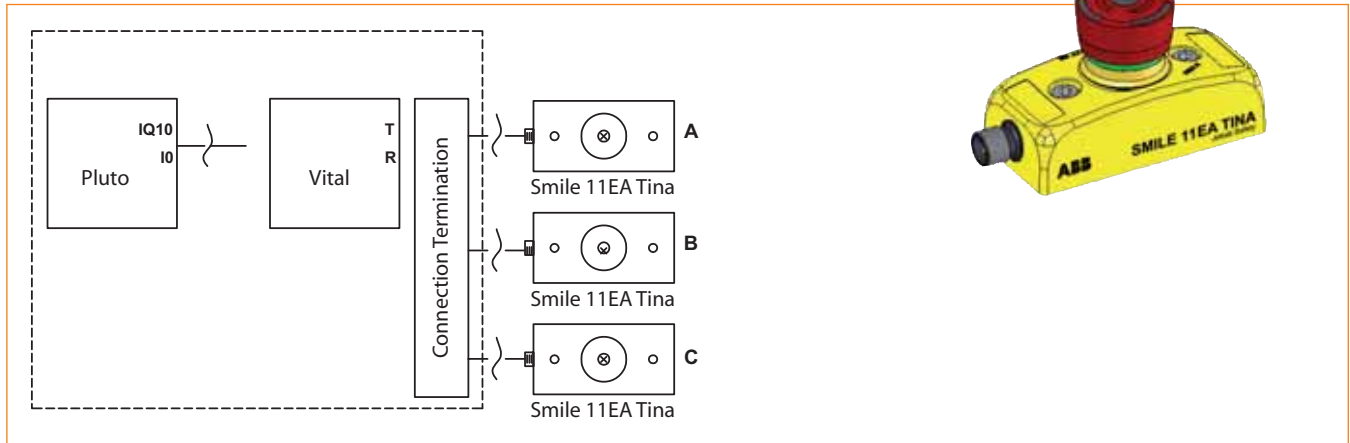

**Smile 11EA Tina** can be connected to either Pluto or Vital system. Safety circuit category 4 with LED indication/information. Connection via M12 connec-

tors. The circuit below shows three Smile 11EA Tina units and one Eden connected in series via a Tina 4A connection block.

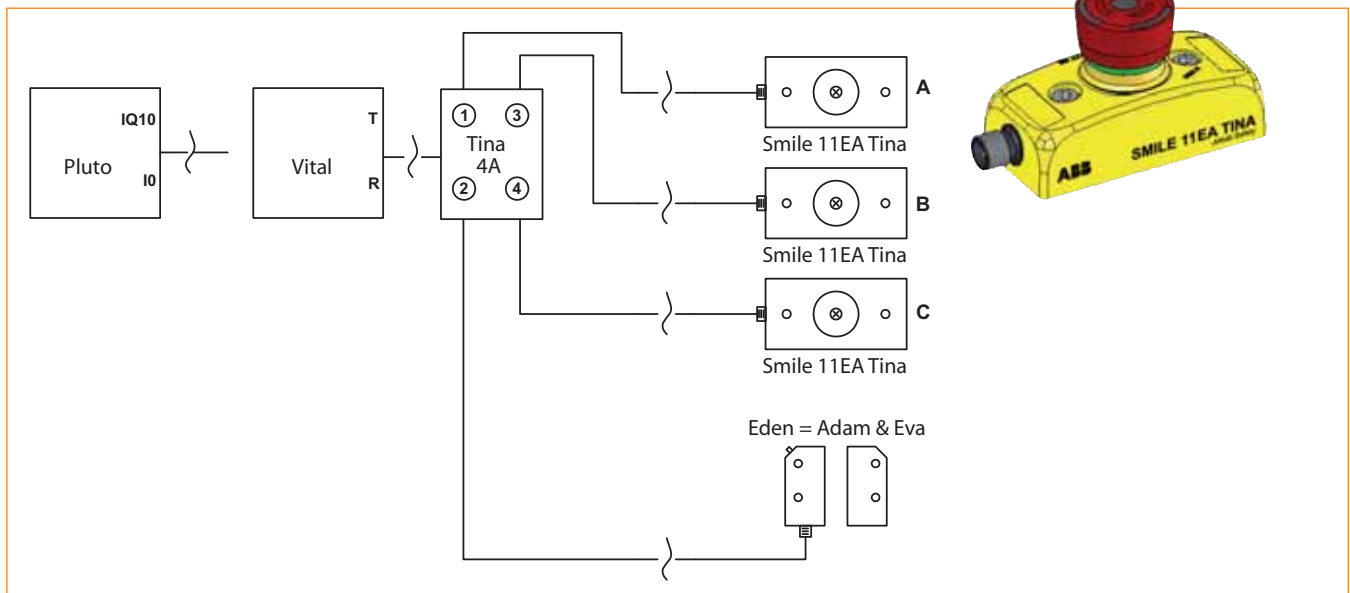

## Smile Tina Connection Examples

The table below shows the information output signal status from each of the **Smile 11EA Tina** units in the connection examples on the previous page. In the example showing connection with an Eden sensor,

the Eden status information signal acts in the same way as the Smile Tina 11EA Units. The status information signal can be connected to, for example, the PLC input.

E-Stop Button Status				Information Output Signal		
A	B	C	↔	A	B	C
R	R	R	↔	H	H	H
R	R	D	↔	H	H	L
R	D	R	↔	H	L	H
R	D	D	↔	H	L	L
D	R	R	↔	L	H	H
D	R	D	↔	L	H	L
D	D	R	↔	L	L	H
D	D	D	↔	L	L	L

A = Smile 11EA Tina  
 B = Smile 11EA Tina  
 C = Smile 11EA Tina  
 R = Released  
 D = Depressed  
 H = High (i.e. supply voltage)  
 L = Low (= 0 VDC)

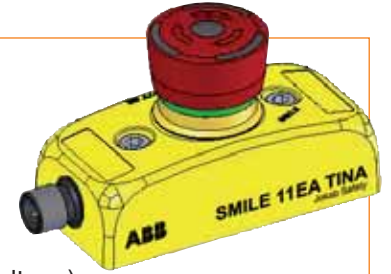

*Note: The information signal must not be used as a safety signal. The signal should only be used to indicate the status of connected devices.*

**Smile 12EA Tina** can be connected to either Pluto or Vital system. Safety circuit category 4 with LED indication/information. Connection via M12 connectors.

The last Smile 12EA Tina unit feeds the dynamic signal back to the Pluto/Vital.

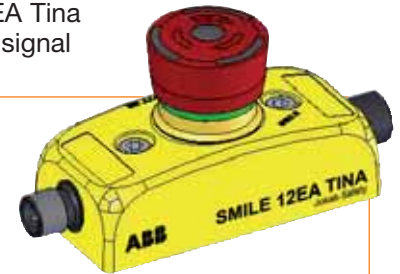
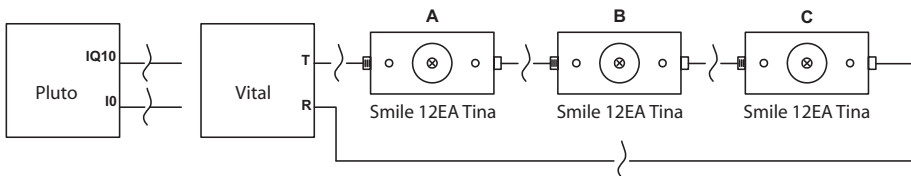

E-Stop Button Status				LED Indication		
A	B	C	↔	A	B	C
R	R	R	↔	G	G	G
R	R	D	↔	G	G	Rd
R	D	R	↔	G	Rd	F
R	D	D	↔	G	Rd	Rd
D	R	R	↔	Rd	F	F
D	R	D	↔	Rd	F	Rd
D	D	R	↔	Rd	Rd	F
D	D	D	↔	Rd	Rd	Rd

The table at the left shows the LED indication status of the E-Stop buttons from the example shown above where three Smile 10EA/11EA/12EA Tina units are connected in series.

A = Smile 11EA/12EA Tina  
 B = Smile 11EA/12EA Tina  
 C = Smile 11EA/12EA Tina  
 R = Released  
 D = Depressed  
 G = Green light from the top of the button  
 Rd = Red light from the top of the button  
 F = Flashes between green and red light

**Smile 12EA Tina** can be connected to either Pluto or Vital system. Safety circuit category 4 with LED indication/information. Connection via M12 connectors. The circuit shows two Smile 12EA TinAs, one Eden sensor and one Focus Light Curtain connected in series.

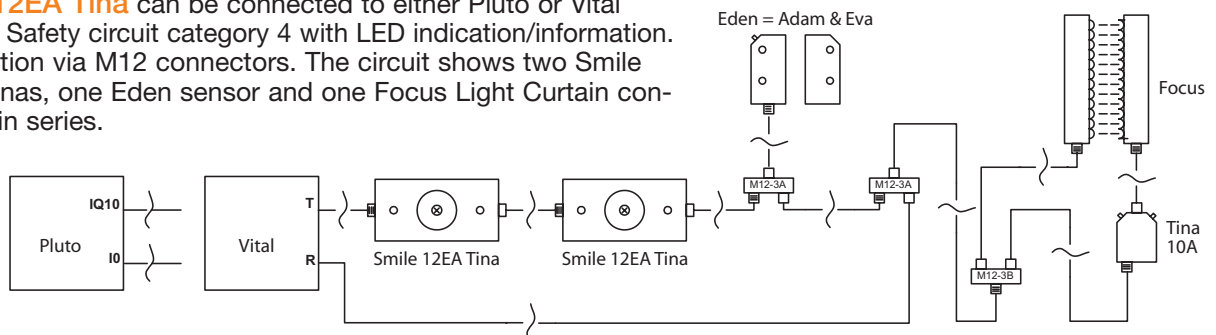

## Smile Tina Technical Data

<b>Manufacturer</b>	ABB AB/Jokab Safety, Sweden
<b>Ordering information</b>	see page 10:19
<b>Impact resistance (half sinusoidal)</b>	max. 150 m/s <sup>2</sup> , pulse width 11 ms, 3-axis, as per EN IEC 60068-2-27
<b>Vibration resistance (sinusoidal)</b>	max. 50 m/s <sup>2</sup> at 10 Hz, 10 cycles, 3-axis, as per EN IEC 60068-2-6
<b>Climate resistance</b>	
Damp heat, cyclical	96 hours, +25 °C / 97%, +55 °C / 93% relative humidity, as per EN IEC 60068-2-30
Damp heat, sustained	56 days, +40 °C / 93% relative humidity, as per EN IEC 60068-2-78
Dry heat	96 hours, +70 °C, as per EN IEC 60068-2-2
Cooling	96 hours, -40 °C, as per EN IEC 60068-2-1
Salt mist	96 hours, +35 °C in a chemical solution with NaCl as per EN IEC 60068-2-11
<b>Level of safety IEC/EN 61508-1...7</b>	SIL 3
<b>PFH<sub>d</sub></b>	4.66E-09
<b>Color</b>	Yellow, red and black
<b>Weight</b>	Approx. 65 grams
<b>Size</b>	Length: 84 mm + M12 contact(s) (12.5mm each) Width: 40 mm Height: 52 mm
<b>Material</b>	Polyamid PA66, Macromelt, Polybutylenterephthalate PBT, Polypropylene PP, UL 94 V0
<b>Ambient temperature</b>	-10°C to +55°C (operation) -30°C to +70°C (stock)
<b>Protection class</b>	IP 65
<b>Mounting</b>	Two M5 hexagon socket screws, L ≥25 mm; Hole centers: 44 mm

<b>LED on E-Stop</b>	
Green	Safety device OK, Safety circuit OK
Flashing	Safety device OK, safety circuit broken
Red	Breaks in safety device and safety circuit
<b>Time delay</b>	1:1.5 (Two Smile units are equal to three Edens in time delay)
<b>Input voltage</b>	17-27 VDC ripple ±10%
<b>Current consumption</b>	47 mA (57mA with max. current from information output)
<b>Current from information output</b>	10 mA max
<b>E-Stop button actuating force</b>	22±4 N
<b>Actuator travel</b>	Approx. 4 mm to latch
<b>Material, contacts</b>	Silver alloy gold plated
<b>Mechanical life</b>	> 50,000 operations
<b>Accessories</b>	
Emergency stop sign S D F, 32.5mm	2TLJ030054R0700
Emergency stop sign E F T, 32.5mm	2TLJ030054R0800
<b>Conformity</b>	EN ISO 13850, EN 60204 EN 60947-5-1 & -5

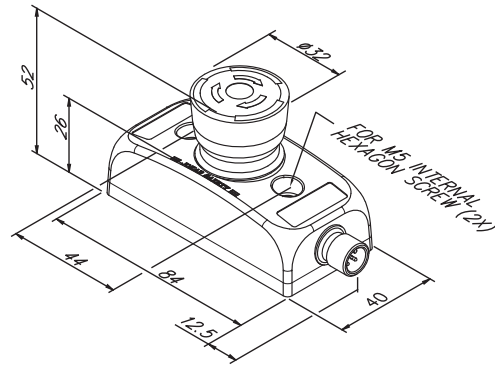

## Smile Connection Examples

### Smile 11EA Tina

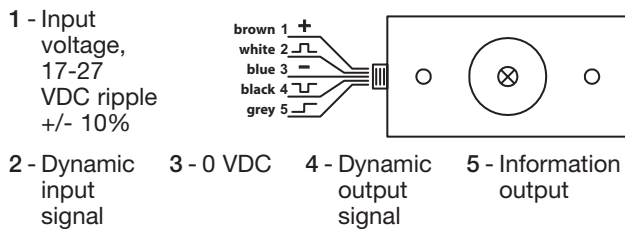

### Smile 12EA Tina

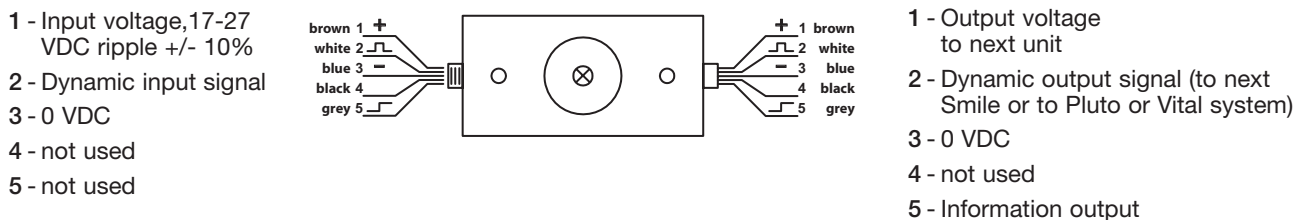

# Smile AS-i Emergency Stop with Indication

Smile 11EA AS-i is an emergency stop with a built-in dual channel safe AS-i input node. The AS-i bus and the safety around it is specified by the two organizations “AS-International Association” and “AS-Interface Safety at Work”, and is described in publications such as “AS-Interface The Automatic Solution”.

Smile 11EA AS-i is supplied with 30 V DC from the AS-i bus. The recommended connection to the AS-i bus is made via a flat cable terminal to M12, which makes it possible to quickly and easily connect the device to the yellow AS-i cable.

Smile AS-i can also be connected directly to the AS-i bus using only two conductors (pins 1 and 3 on the unit's M12 contact). Smile is also available with black push button and is used in this case as a safety stop. See page 10:18.

## Regulations and Standards

The Smile Emergency Stop is designed and approved in accordance with appropriate standards. Examples of such are: EN ISO 13850:2006, EN ISO 13850, EN 60204, EN 60947-5-1 and EN 60947-5-5.



## Applications

- To stop a machine or a process
- Safe input node in AS-i systems

## Features

- Emergency push button up to Category 4 PL e according to EN ISO 13849-1
- Simple connection AS-i bus
- LED indication on push button and AS-i status indication
- Robust construction
- Push button IP 65, housing IP67
- Available as safety stop with black push button

## Approvals



## Smile AS-i Technical Data

Manufacturer	ABB AB/Jokab Safety, Sweden
Ordering information	see page 10:19
AS-i data AS-i profile Addressing Node address on delivery Response time across the AS-i bus	S-7.B.0 M12-contact 0  5 ms (+ response time for safety monitor)
Pin configuration (1) (2) (3) (4) (5)	AS-i + Not used AS-i - Not used Not used
Voltage supply Output voltage Total current consumption	30 V DC from the AS-i bus Tolerance 26.5 – 31.6 V DC < 60 mA
General Enclosure protection class Ambient temperature Dimensions Color  Actuating force Actuating movement	IP65 -25...+50°C 52 x 40 x 84 (+12.5 mm M12 contact) (H x B x D) Base: yellow Emergency stop button (Smile 11EA AS-i): red Safe stop button (Smile 11SA AS-i): black 22 ±4 N Ca 4 mm to latch
Mechanical life	> 50,000 operations
PFH <sub>d</sub>	6.95x10 <sup>-9</sup>
Safety/Harmonized standards IEC/EN 61508-1..7 EN 62061 EN ISO 13849-1 EN 60947-5-1 & -5 EN ISO 13850:2008 Certification	SIL3, PFD <sub>avr</sub> : 2.95x10 <sup>-5</sup> SIL3 Performance level PL e, Category 4, MTTF <sub>d</sub> : high For emergency stop buttons/ safety stop buttons For emergency stop buttons/ safety stop buttons TÜV Nord

### LED in Emergency Stop Button

LED displays can be individually programmed in the PLC program as shown below.

LED in push-button	Indicator	Description
Red	ON	Output bit 1 ON
	OFF	Output bit 1 OFF or Output bit 1 & 2 ON
Green	ON	Output bit 2 ON
	OFF	Output bit 2 OFF or Output bit 1 & 2 ON

### AS-i LED and Fault LED in Combination

LED pair at the M12 contact.

AS-i (Green)	Fault (Red)	
OFF	OFF	AS-i voltage missing
ON	OFF	Normal operation
ON	ON	No data exchange with master
Flash	ON	No data exchange due to address = 0

# Stop-Line Emergency-Stop Grab Wire Safety Switch

## Duplicated Safety in Both Directions

Stop-Line is used for easy reach of an emergency stop along machines, conveyors and processes. Stop-Line is easier to install than a system of several emergency stop buttons along a carriage path. Stop-Line indicates operation status, reset or triggered mode. There is also indication of how taut the wire is.

Stop-Line can be used as protection for conveyors with low risks. The wire can, for example, be installed at waist height in front of the conveyor, which provides an emergency stop if someone falls towards the conveyor.

Stop-Line has four contacts. If someone pulls the wire or if the wire is broken, all the contacts are affected. In both cases, the machine is emergency-stopped. Just before the safety contacts are broken an indication is given since the wire may accidentally trigger the stop signal as a result of temperature differences.

To reset the Stop-Line, the combined emergency and reset button must be pulled out.

## Forced Disconnected Contacts

The contacts of the Stop-Line are forced disconnected. Forced disconnection means that the contacts are mechanically pulled apart, thus ensuring protection against contact welding or sticking.

## Safety Level

The forced disconnected contacts provide a high level of safety. To achieve a high level of safety in the machine control system, it is appropriate to use a safety relay, Vital controller or Pluto Safety PLC manufactured by ABB Jokab Safety. Stop-Line can be combined with Tina devices for use in a safety circuit containing other safety devices and emergency stops according to PL e.



## Applications

- Emergency stop grab wire safety switch along machines or conveyors

## Features

- Emergency switch up to Category 4 PL e according to EN ISO 13849-1
- Duplicate extraction in two directions
- Up to 75m in length
- Robust construction
- IP 67
- Integrated emergency stop button
- Warned before safety circuit is broken

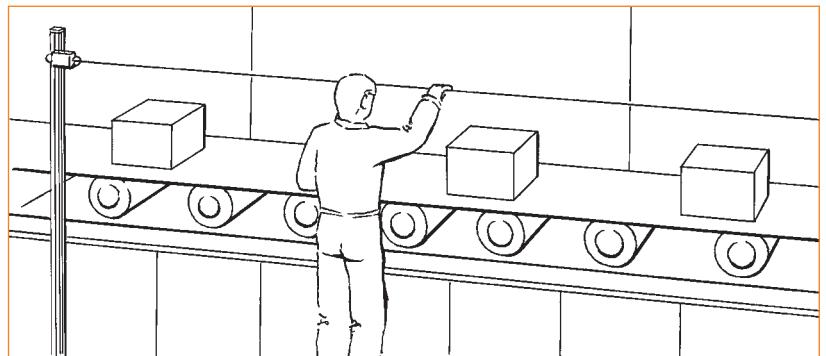

*Emergency-Stop Grab Wire is easily accessible during normal work operation.*

## Regulations and Standards

The Stop-Line is designed and approved in accordance with appropriate standards. See Technical Data.

## Approvals



## Stop-Line Technical Data

Manufacturer	ABB AB/Jokab Safety, Sweden
Ordering information	see page 10:20
Color	Black with yellow label
Level of safety	Cat. 4/PL e, EN ISO 13849-1
Housing material	Cast aluminium
Lid material	Cast aluminium
Operating temperature	-30°C to +80°C
Switching contacts	2 NC + 2 NO
Protection class	IP 67, EN 60529
Mechanical life	100,000 switching cycles
Max. switching frequency	20/min
Reset method	mushroom-head slam button
Max. wire length	37.5 m/75 m
Mounting	4 x M5/4 x M6
Terminals	Screw terminal, 8 x M4
Cable access	3 x M20 x 1.5
Weight	0.9 kg
Max. voltage	250 VAC
Information output	
Rated voltage	Ue 10-30 V DC
Rated current	Ie 50mA
Thermal current	10A
Utilization category	AC 15, DC 13
Short-circuit protection	Melting Fuse 6A DII type gG
Conformity	EN ISO 13849-1 EN ISO 13850, EN60947-1 EN 60947-5-1, VDE 0113 EN ISO 12100-1, -2 och VDE 0660 T200

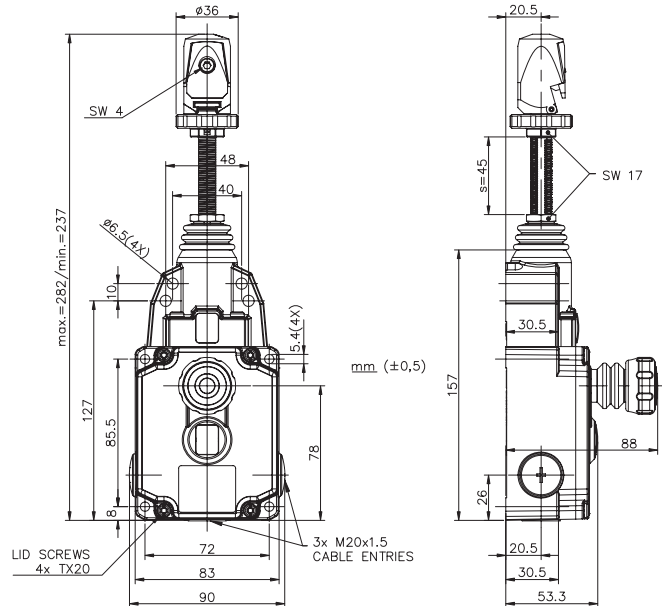

## Stop-Line Mounting

The wire should be mounted at least 20 mm from the underlying surface. If the wire is longer than 25 m it must be supported with low friction supports. The ambient temperature during installation should be the

same as during operation. For the Stop-Line type A, after installation pull the wire strongly several times and then adjust the tension to compensate for any extensions due to deformation of the thimbles.

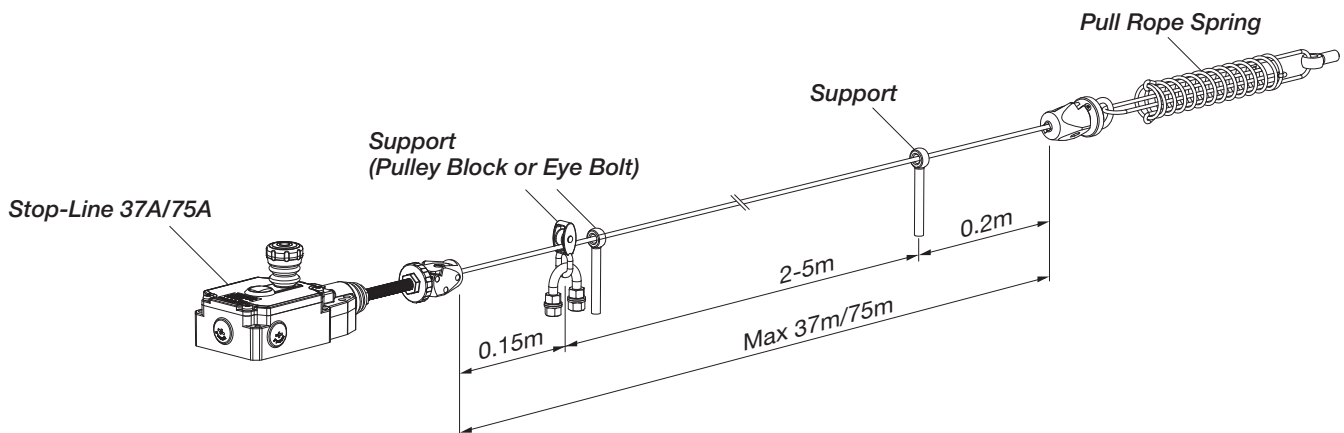



## Stop-Line Contact Adjustment

The tension is adjusted using the built-in set screw until the arrowhead is aligned with the label in the window. (See picture below.) When the combined emergency and reset button is then pulled making the status window show green, all contact pairs are in operational mode and the machine can be started.

Pulling the wire, or if the wire is broken, all the contact pairs shift position and the machine is stopped.

Before doing so, an electronic warning signal is provided which can be used to alert an operator to compensate for slow variations of the tension in the Stop-Line wire. This is useful to avoid unnecessary stops caused by e.g. ambient temperature variations.

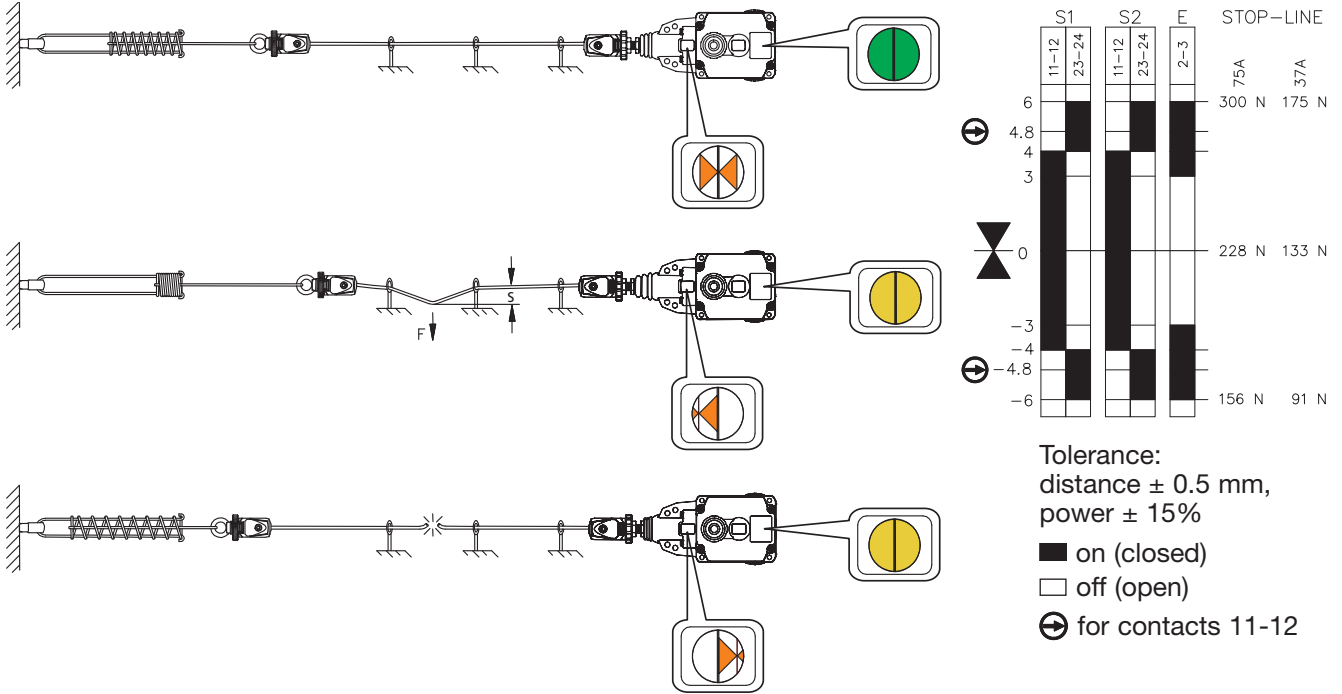

## Stop-Line Electrical Connection

Electrical connection of Stop-Line, highest level of safety.

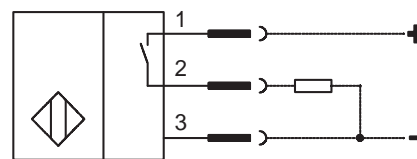
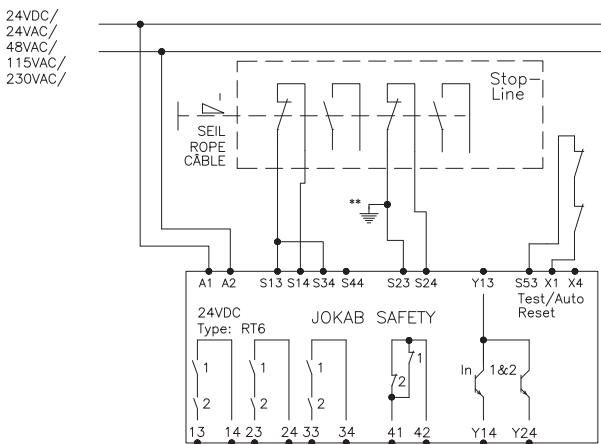

Connection terminal 1 and 3:  
 Connection of supply voltage 10-30V DC

Connection terminal 2 and 3:  
 Connection to signal circuit or lamp for indication

*Note: The connection shows the Stop-Line in a correctly tensioned condition.*

## Smile and Inca Safety Stops

Safety stops are used to stop the operation of a machine in a safe manner. It must not be used as an emergency stop, but only as a stop for an individual hazardous motion. This is indicated by black push button. Likewise, an emergency stop push button with red push button must not be used as a safety stop.

### Smile with Indication

The Smile series is available with black push button and has a similar designation apart from an S in the name instead of E. The safety stops are identical to the corresponding emergency stops apart from the black push button. For technical data see the Smile emergency stop.

### Inca for Panel Mounting

The Inca series is available with black push button and is called Inca 1S/Inca 1S Tina. The safety stop is identical to the corresponding emergency stop apart from the black push button. For technical data see the Inca emergency stop.



## Smile 11R Reset Button

Smile 11RA/B are reset push buttons intended to reset safety circuits. Smile 11RA has connections for the NO-contact and for the LED in the push button. The reset LED is to be turned off after reset of the safety circuit. Smile 11RB is used together with our Pluto Safety PLC in order to reduce the number of terminals— one terminal is used as both input for the reset as well as output for the LED.





### Smile 11R Technical Data





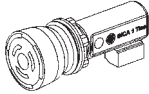
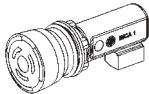
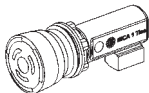
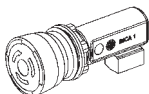

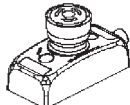
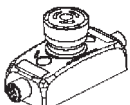
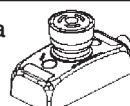
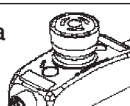
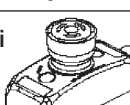
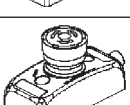
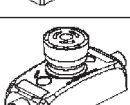
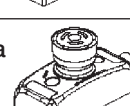
Manufacturer	ABB AB/Jokab Safety, Sweden
Ordering information	see page 10:20
Color Base Pushbutton	yellow blue
Material Housing Push button contact	Polypropylene PP Au
Power Supply LED operating voltage LED current consumption	24 VDC (maximum 33 VDC) 20 mA at 24 VDC 30 mA at 33 VDC
Pushbutton operating voltage Pushbutton current consumption Pushbutton rated power	Min: 5 V, max: 35 V Min: 1 mA, max 100 mA Max: 250 mW

Ambient temperature	-25...+55°C
Humidity range	35 to 85% (with no icing or condensation)
Protection class	IP65
Connectors	5-pole male M12 connector
Size	84x40x36 (LxWxH) + 12 mm for M12 connector (L)
Weight	approx. 60 g
Mechanical life	1,000,000 operations at 10 mA/24 VDC
Switching reliability	10 x 10 <sup>-6</sup> at 5 mA/24 VDC

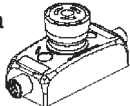
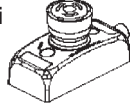
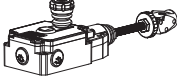
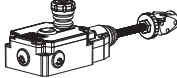
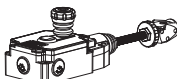
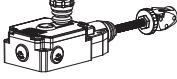







## Component List - Emergency Stops

Designation	Ordering Information	Description
INCA 1	 2TLJ030054R0100	Emergency stop button for panel mounting with mechanical contacts. Red/green LED.
INCA 1 Tina	 2TLJ030054R0000	Emergency stop button for panel mounting with Tina function and dynamic function principle. Red/green LED. For use with Vital/Pluto.
INCA 1S	 2TLJ030054R0300	Safety stop button for panel mounting with mechanical contacts. Red/green LED.
INCA 1S Tina	 2TLJ030054R0200	Safety stop button for panel mounting with Tina function and dynamic function principle. Red/green LED. For use with Vital/Pluto.
INCA Yellow Surround	 2TLJ030054R0400	Yellow surround for emergency stop button.
Smile 11EA	 2TLJ030051R0000	Emergency stop, 2 x NC, 1 x M12 5-pole male connector. Red/green LED.
Smile 12EA	 2TLJ030051R0200	Emergency stop, 2 x NC, 1 x M12 5-pole male connector, 1 x M12 5-pole female connector. Red/green LED.
Smile 11EA Tina	 2TLJ030050R0000	Emergency stop for Vital/Pluto, 1 x M12 5-pole male connector. Red/green LED.
Smile 12EA Tina	 2TLJ030050R0200	Emergency stop for Vital/Pluto, 1 x M12 5-pole male connector, 1 x M12 5-pole female connector. Red/green LED.
Smile 11EA AS-i	 2TLJ030052R0000	Emergency stop with built-in dual channel safe AS-i input node, Red/green LED. 1 x M12 5-pole male connector.
Smile 11SA	 2TLJ030051R0900	Safety stop, 2 x NC, 1 x M12 5-pole male connector. Red/green LED.
Smile 12SA	 2TLJ030051R1000	Safety stop, 2 x NC, 1 x M12 5-pole male connector, 1 x M12 5-pole female connector. Red/green LED.
Smile 11SA Tina	 2TLJ030050R0500	Safety stop for Vital/Pluto, 1 x M12 5-pole male connector. Red/green LED.

## Component List - Emergency Stops

Designation	Ordering Information	Description
Smile 12SA Tina 	2TLA030050R0600 2TLJ030050R0600	Safety stop for Vital/Pluto, 2 x NC, 1 x M12 5-pole male connector, 1 x M12 5-pole female connector. Red/green LED.
Smile 11SA AS-i 	2TLA030052R0100 2TLJ030052R0100	Safety stop with built-in dual channel safe AS-i input node, 1 x M12 5-pole male connector. Red/green LED.
Stop-Line 75A 	2TLJ020041R0000	Emergency stop grab wire safety switch with integrated expansion spring, 2 NC contacts for safety circuit, 2 NC contacts for status, 1 NO contact for warning, 75m length. Quick connect head.
Stop-Line 37A 	2TLJ030042R0000	Emergency stop grab wire safety switch, 2 NC contacts for safety circuit, 2 NC contacts for status, 1 NO contact for warning, 37m length. Quick connect head.
Stop-Line 75B 	2TLJ020041R0100	Emergency stop grab wire safety switch with integrated expansion spring, 2 NC contacts for safety circuit, 2 NC contacts for status, 1 NO contact for warning, 75m length. Conventional head.
Stop-Line 37B 	2TLJ030042R0100	Emergency stop grab wire safety switch, 2 NC contacts for safety circuit, 2 NC contacts for status, 1 NO contact for warning, 37m length. Conventional head.
Stop-Line Installation Kit 1	2TLJ020043R1200	Mounting kit for use with Stop-Line emergency stop grab wire switch, including 25m x 3mm wire (sheath 4mm), 6 wire clamps, 6 thimbles, 1 turnbuckle, 8 eye bolts (M8x50).
Stop-Line Installation Kit 2	2TLJ020043R1300	Mounting kit for use with Stop-Line emergency stop grab wire switch, including 40m x 3 mm wire (sheath 4mm), 1 pull wire spring, 9 pulley blocks, 9 fasteners for pulley block.
Wire 3mm (sheath 4mm) 	2TLJ020034R0500	Red plastic coated wire for use with Stop Line.
Wire Clamp for 3mm 	2TLJ020034R0400	Duplex wire clamp for 3mm Stop-Line wire.
Thimble 	2TLJ020034R0300	Wire thimble for use with wire clamp and 3mm Stop-Line wire.
Turnbuckle 	2TLJ020034R0600	Wire turnbuckle M6 x 60 for tensioning Stop-Line 3mm wire.
Eye Bolt M8x50 	2TLJ020034R0900	Eye bolt for use with 3mm Stop-Line wire.

## Component List - Emergency Stops

Designation		Ordering Information	Description
Pull wire spring QF75		2TLJ020043R0000	Pull wire spring for use with Stop-Line 75.
Pull Wire Spring QF37		2TLJ020043R0100	Pull wire spring for use with Stop-Line 37.
Pulley Block, Unhinged		2TLJ020043R0300	Pulley block for use with Stop-Line 37/75.
Fastener for Pulley Block		2TLJ020043R0600	Fastener for use with Stop-Line 37/75 pulley block.
Pulley Block, Hinged		2TLJ020043R0400	Hinged pulley block for use with Stop-Line 37/75.
Deflection Pulley Ø 75mm		2TLJ020043R0200	Deflection pulley for use with Stop-Line 37/75.
Smile 11RA		2TLJ030053R0000	Reset push button, 1 NO, 1 LED, 1 x M12 5-pole male connector.
Smile 11RB		2TLJ030053R0100	Reset push button for use with the Pluto Safety PLC, 1 x M12 5-pole male connector.
Termination Device JST2		2TLJ030051R1300	Smile 12 termination device.

This document and any attachments may include suggested specifications, drawings, schematics and similar materials from ABB Inc. Use of such information and/or documentation by the recipient is subject to and conditioned upon your acceptance of the terms of the General Document Disclaimer which can be found at [www.jokabsafety.com](http://www.jokabsafety.com). Your acceptance of the terms of such General Document Disclaimer is conclusively presumed unless you notify ABB in writing of your disagreement with the terms of such Disclaimer immediately upon receipt of this document and you return to ABB all specifications, drawings, schematics and similar materials provided to you by ABB.

# Notes

# Contact Edges, Bumpers and Safety Mats

Protection against crushing accidents!  
Protection around hazardous machinery!  
Personal protection within dangerous areas!

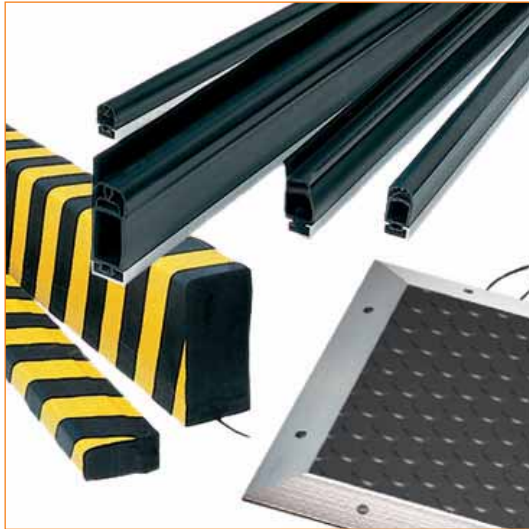

When should I use Contact Edges, Bumpers and Safety Mats? .....	11:2
Safety Contact Edges and Bumpers .....	11:3
Technical Data.....	11:4
Mounting and Electrical Connections.....	11:7
The Safety Bumper Principle .....	11:8
Standard Shapes .....	11:9
Safety Mats .....	11:10
Technical Data.....	11:11
Electrical Connection .....	11:13
Connection Examples .....	11:14
Component List and Ordering Information .....	11:15



# When should I use Contact Edges, Bumpers and Safety Mats?

...to be able to stop a machine during crushing accidents or around hazardous machinery!

## Contact Edges and Bumpers

Contact edges are used as protection against crushing accidents, i.e. on moving machine parts and automatic doors and hatches. The strips come in customized lengths and various cross sections.

Bumpers are used as safety buffers to protect against remote control transport vehicles and other dangerous moving objects that require long stopping distances.

## Safety Mats

Safety mats are used for protection around hazardous machinery. They are well suited for monitoring an area used for loading and unloading of material to a machine.

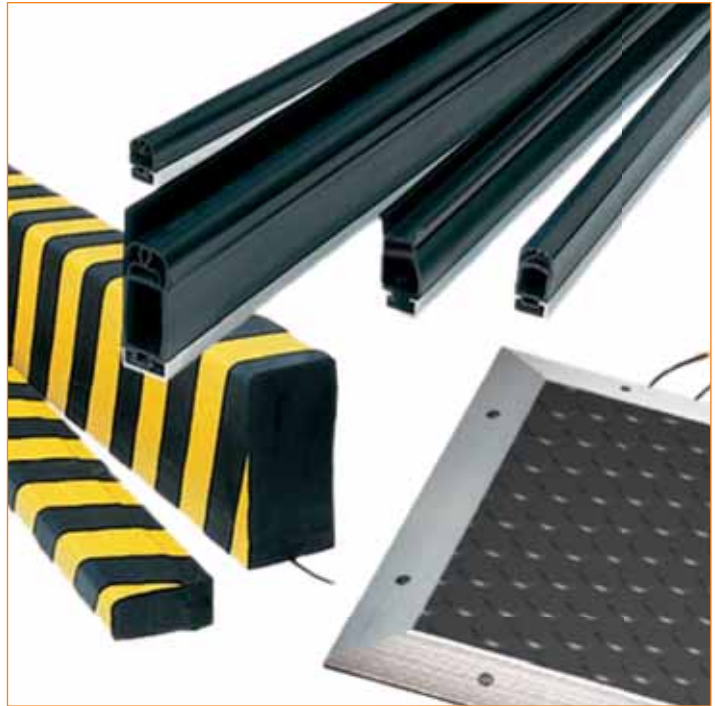

## Requirements for Contact Edges, Bumpers and Safety Mats are stated in these standards and regulations

### EN 1760-1 Safety of Machinery

*Pressure Sensitive Protective Devices – Part 2: General requirements.*

General principles for the design and testing of pressure sensitive edges and pressure sensitive bars.

### EN 1760-1 Safety of Machinery

*Pressure Sensitive Protective Devices – Part 1: General requirements.*

General principles for the design and testing of pressure sensitive mats and pressure sensitive floors.



# Safety Contact Edges and Bumpers

## Safety Contact Edges

Contact edges are used as protection against crushing injuries, for example, moving machine parts, automatic doors.

### Contact Edges with Cast-in Contact Strips

Our new contact edges consist of a rubber profile with a cast-in contact strip. They are made up simply using connection plugs that are glued to the ends together with a terminal cap. The rubber profile is fitted on an aluminium profile and is available in EPDM design, supplied in lengths up to 25 m.

### Contact Edges with Contact Strips SKS18

The contact edge consists of a rubber profile with a safety contact strip inside. The contact edge is fitted on an aluminium profile.

The special design of rubber profiles of EPDM or NBR rubber protect the inner contact strip in the best way possible against damage and also allow for a contact angle exceeding  $\pm 45^\circ$ . Normally supplied in lengths up to 25 m.

## Bumpers

Bumpers are employed on automatic production lines to minimize danger to both people and machines. The large foam rubber cushions enable long practical braking and run-through distances, thus enabling designers to optimize protection for both personnel and machines.

The safety contact strips are mounted inside aluminium profiles which are, in turn, protected by the large foam cushions that are glued to the carrier profile and then sprayed with a thin film of polyurethane which makes the bumper waterproof and helps to minimize wear and tear.

The bumpers are delivered mounted to the carrier profile in ordered lengths (0,2 m – 3 m).



## Applications

- Protection against crushing accidents on moving machine parts and automatic doors

## Features

- Can be connected to a safety relay, Vital or Pluto Safety PLC
- IP 65
- Simple assembly on site
- Lengths up to 25 m

## Approvals



## Fields of Application

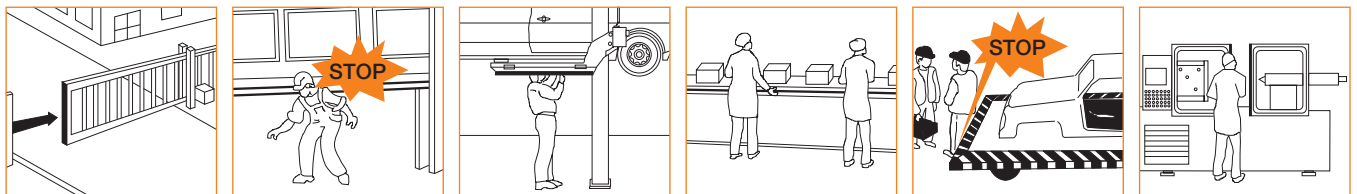

## Safety Contact Edges GP - General

The safety contact strip, SKS 18, the actual contactor, is located inside the safety contact edge. The safety contact strip consist of a homogeneous highly insulating outer EPDM material and has two internal conducting contact surfaces. The conducting elastomer contains two copper wires that provide low-resistance detection even in lengths exceeding 100 metres.

Because of the contact points, the safety contact edge has approximate 20 mm of inactive length at each end.

To provide protection against damage and to enable its proper use, the safety contact strip is inserted into the switching chamber of the rubber contactor profile. The rubber profiles (EDPM or NBR) are then permanently sealed with a special elastic adhesive and end caps to make them watertight.

The safety contact edge is then pressed into the aluminium profile.

## Safety Contact Edge, Construction

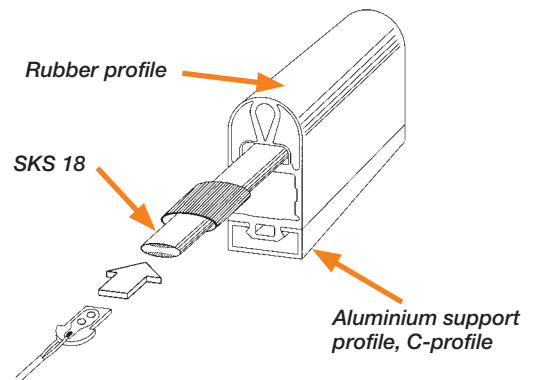

## Safety Contact Strip SKS 18 for Contact Edge GP Technical Data

Outer material	EPDM, electrical insulation >30 Mohm
Inner material	EPDM, electrical elastomer with reinforce copper wire
Conductivity	60 ohm / 100 meters
Contact resistance	approx. 50 ohm
Max. electrical load	24 V / 100 mA
Max. applied pressure	6.5 N/cm <sup>2</sup>
Dimensions	18 x 6 mm

## Safety Contact Strip SKS 18

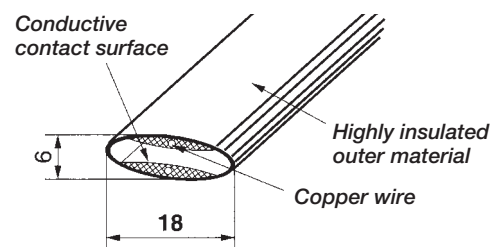

## Construction - Contact Edge GE

Inside the contact edge there is a cast-in contact strip that consists of two conductive alternating surfaces on the inside and a highly-effective insulating shell. There are two conductive wires in the contact surfaces that allow for low ohm measurements even when the contact edge has an extended length. The cast-in contact strip is protected against damage by the surrounding chamber. The cast end plugs ensure a permanent contact from the conductive surfaces in the contact strip. A special flexible adhesive is used to make the connector ring watertight.

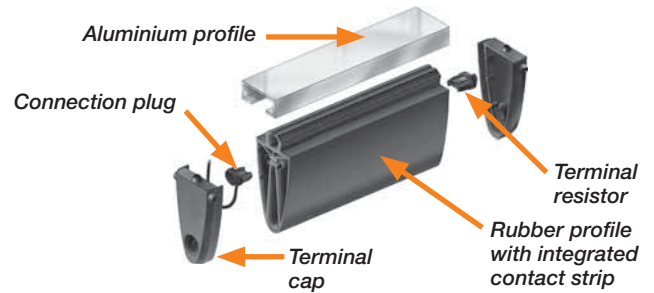

## Rubber Profiles Technical Data

Type		GP 25-25	GP 25-40	GE 25-25	GE 25-45
Fixing Profile		AL 25-14	AL 25-14	AI 25-14	AI 25-14
Material		EPDM/NBR	EPDM/NBR	EPDM	EPDM
Length max (m)	(1)	6(10)	6(10)	25	25
Weight (g/m)		370	480	510	770
Weight incl. C-Profile (g/m)		690	800	820	1080
Activation force (N)	(2)	34/37	39/52	64,1	69,1
Actuating distance (mm)	(3)	8.0/7.5	9.4/9.7	4,7	6,73
Braking distance (mm)	(3)	7.2/5.9	10.2/9.5	6.48	20.73
Max. Actuating (°)	(4)	2x 45°	2x 60°	2x20°	2x20°

- (1) 10-metre lengths of GP edges on request
- (2) Measured with (Ø 80 mm test specimen), 10 mm/s
- (3) Measuring speed 10 mm/s
- (4) Not including DIN 31006-2 (GS - BE - 17)

**Note: Contact us for other profile sizes.**

## Contact Edge Technical Data

Manufacturer	ABB AB/Jokab Safety, Sweden
Ordering information	see pages 11:15-11:16
Mechanical load max <sup>1</sup>	500 N
Actuating angle (DIN) <sup>1</sup>	2x 20°
Mechanical life <sup>1</sup>	10 <sup>5</sup>
Max. operate temp. range <sup>2</sup>	-20C° to +55°C
Max. temperature range	-25°C to +70°C
Protection classification	IP 65
Max. Electrical load	24V 100mA
Resistance	0.6 Ohm/m
Conductors	GP: 2x 0.38 mm <sup>2</sup> GE: 2x 0.34 mm <sup>2</sup>
Conductors insulation material	GP: PVC GE: PUR matt blackt

(1) According to DIN 31006-2 (GS - BE - 17)

(2) Not including DIN 31006-2 (GS - BE - 17)

## Physical and Chemical Material Properties

Properties	EPDM	NBR
Tensile strength	3	2
Tensile elongation	3	2
Durability	3	2
Tear resistance	3	3
Cold flexibility	2	3
Heat resistance	2	2
Oxidation resistance	1	3
UV-resistance	1	3
Weather/ ozone resistance	1	3
Flame resistance	6	6
Gas permeability	4	2

*1 = excellent - 6 = poor*

Resistance	EPDM	NBR
Water (distilled)	1-2	1
Acids (diluted)	1	3
Bases (diluted)	2	2
Non-oxidised acids	2	3
Oxidised acids	4	5
ASTM oil No. 3	6	1
Vegetable oil	5	1
Ester solvent	2	5
Ketone solvent	3	5
Aliphatic hydrocarb.	5	1
Aromatic hydrocarb.	6	2-3
Halogenic hydrocarb.	6	5
Alcohols	1	5

<b>1 = no effect</b>	for lasting contact
<b>2 = slight effect</b>	non-lasting contact
<b>3 = moderate effect</b>	moderate contact
<b>4 = appreciable effect</b>	limited contact
<b>5 = strong effect</b>	short-term contact
<b>6 = extreme effect</b>	avoid contact

<b>EPDM</b>	Good resistance to ozone and weather, especially against chemicals
<b>NBR</b>	Good resistance to oil and petrol
<b>ASTM</b>	American Society for Testing Material
<b>Kw</b>	Aromatic hydrocarbon
<b>Ester</b>	Organic solvent
<b>Ketone</b>	Oxidized solvent
<b>Aliphatic</b>	i.e. petrol
<b>Aromatic</b>	i.e. benzol

*Note: The information given is based on data obtained from the respective material suppliers. Although all efforts have been made, unforeseen factors can have a considerable effect on the generally applied indications during practical use therefore this information must be used as a general guide only. If there is any doubt as*

*to the suitability of the materials used for any specific application/ environment, we will, upon request, supply rubber samples for your own evaluation or, if given written specifications of your proposed environmental conditions, test the suitability of materials for your specific application.*

## Mounting and Electrical Connection – Safety Contact Edges

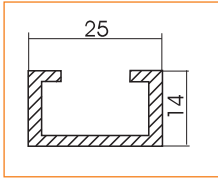

The selected contact profile should be mounted using a suitable aluminium C profile (as shown opposite).

### Mounting - Safety Contact Edges

#### Stage 1 GP and GE

Pan or round-head screws should not be used to mount the aluminium C profile. If such screws are used this can result in the connecting wire in the aluminium profile being damaged.

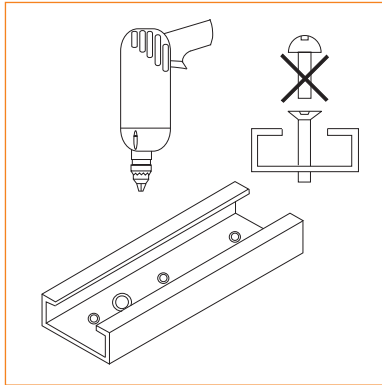

#### Stage 2 GP and GE

In order to feed the connecting wire through the profile, an 8 mm hole must be drilled in a suitable position. Carefully remove the burr from the hole edges and insert the supplied rubber collar. The connecting wires can also be placed in the aluminium profile.

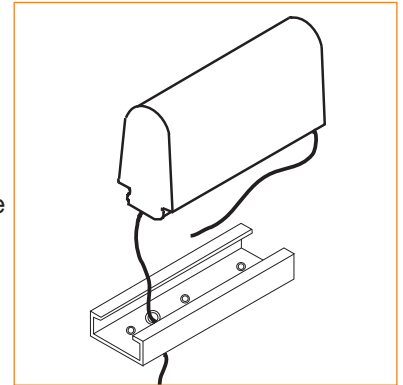

#### Stage 3 GP

In order to make fitting of the safety contact edge easier, the aluminium profile and the safety contact edge should be sprayed with a water based soap solution. One side of the rubber profile must then first be inserted into the profile and then the whole profile pressed in. Once the soap solution has evaporated, the contact strip will be firmly fitted into the profile. In order to prevent subsequent slipping of the safety contact edge, talcum powder, oils or similarly permanent lubricating agents must not be used.

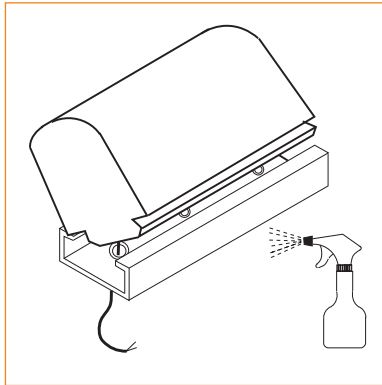

#### Stage 3 GE

Safety contact edges with a t-base have to be pushed into the aluminium profile.

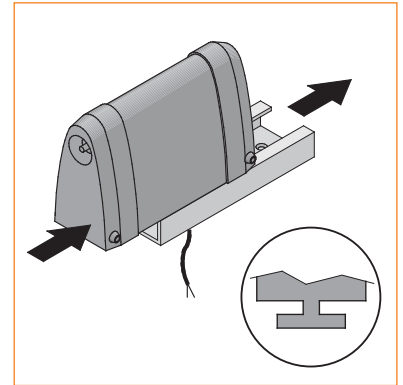

**Note:** Pulling or pushing the safety contact edge into the aluminium profile can cause damage to the contact edge and should be avoided at all costs. Any other proposed methods of fixing should only be attempted after consultation with ABB Jokab Safety. Other methods of fixing, unless approved by ABB Jokab Safety may invalidate the warranty and may lead to incorrect device operation.

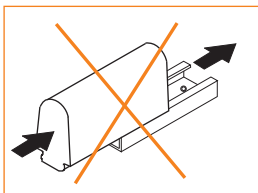

## The Safety Bumper Principle

The contact function of the ABB Jokab Safety bumper consists of the safety contact strip SKS 18 being actuated by a special mechanical construction. This construction, which is protected by a large foam cushion, is inserted and glued to the carrier profile. The foam rubber is covered with a polyurethane skin. The safety bumper is also covered with cross-bound polyurethane, which can be provided in a range of colours. By utilising this construction the bumper gives a stop signal when impacted from all directions with soft sides.

The Safety Bumper must be connected to a suitable two input channel Safety Relay. e.g. ABB Jokab Safety type RT6 or RT7 which provides all necessary monitoring of the bumpers activation and detection of cable faults.

The twin cable connection makes it possible to connect several bumpers in series.

For further information and examples of electrical connection see Connection examples.

## Bumps Technical Data

Ordering information	see page 11:16
Dimensions	in accordance with the illustration, or special dimensions
Actuating distance	approx. 20% of height
Braking distance	at least 50% of height
Actuating force [N]	150 N at 80 mm around the test specimen
Life	greater than 10 <sup>5</sup>

Protection class	IP 65
Ambient temperature	-20° to +60°
Chemical resistance Oil, grease 10% acid 10% alkaline (caustic) solutions	good resistant resistant
Connection cable	2 x 2 m; 2 x 0,34 mm <sup>2</sup> PU covered

*Foam rubber core*

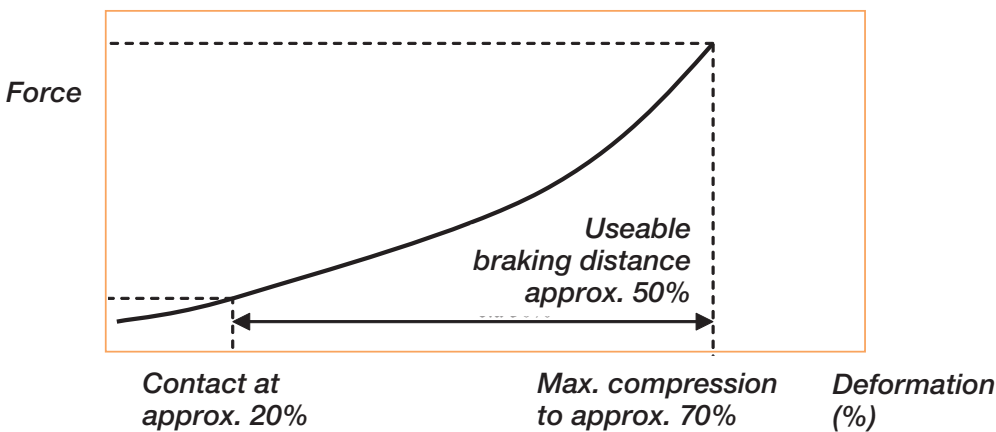
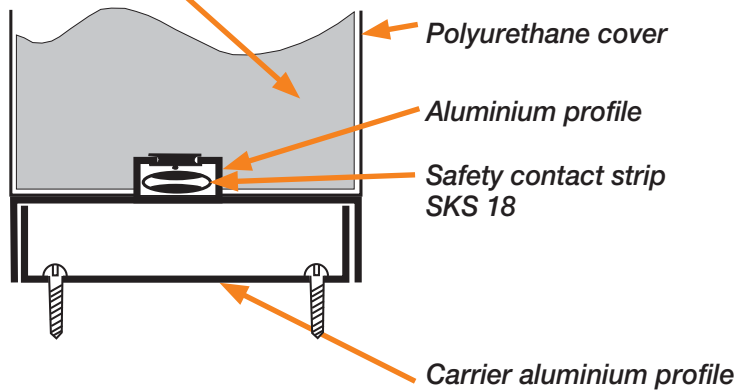

## Standard shapes

Shape A

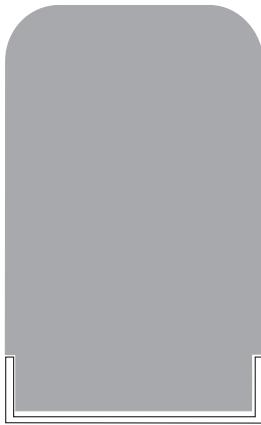

Shape B



Customer-Specified Special Shape



Cable exits at the ends of the bumper or according to customer requirements.

## Dimensions

Bumpers are available in four different standard dimensions. Other dimensions can be supplied on request. Note that in the case of customized orders,

the ratio of 2:1 for X:Y must not be exceeded. Bumpers can be supplied in lengths of up to 3000 mm. The minimum cross-section is 53 x 100 mm.

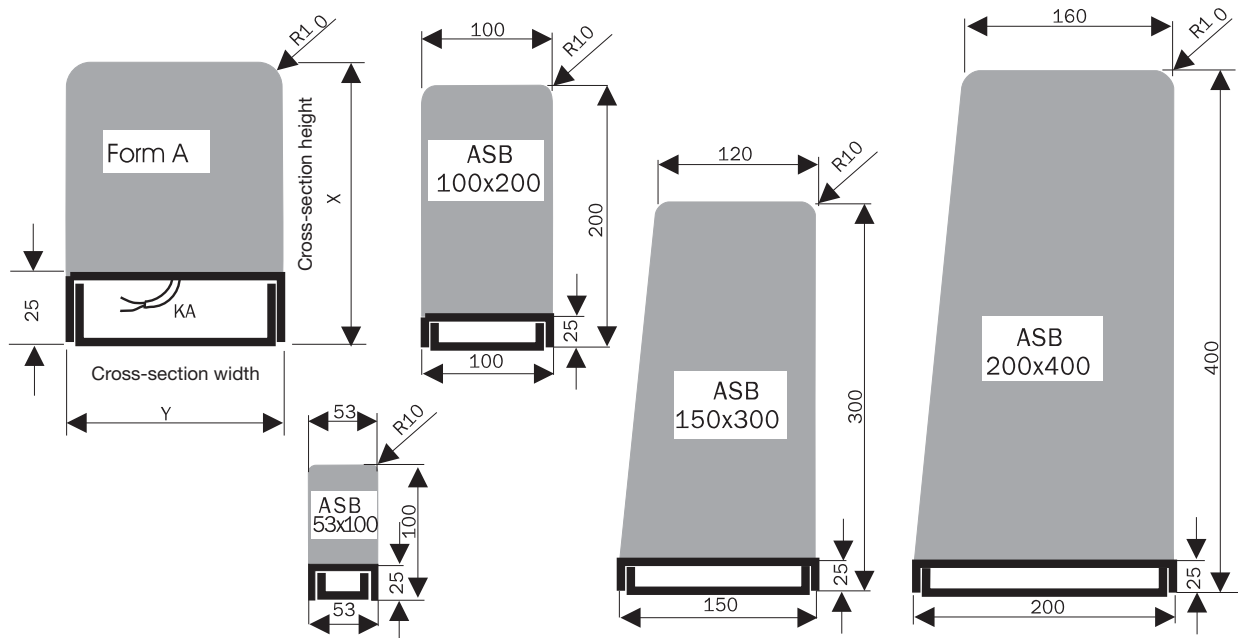

# Safety Mats

## A Safety Mat used as Personal Protection Within Dangerous Areas

The ASK Safety Mat is used as personal protection within the dangerous areas around presses, robots, production lines, machines etc.

When connected to a suitable monitoring system stepping on the Safety Mat will immediately be detected causing dangerous machine movements to be stopped. This is made possible by the detection of electrical contacts closing within the sandwich construction of the Mat. As a load-bearing component the Mat is made with a bottom plate of either synthetic material or metal. The Safety Mat is provided with a slip-free surface, which is fixed by adhesive to the surface of the Safety Mat.

The safety mat and its connection cabling can be supervised by a suitable ABB Jokab Safety safety relay, Vital Controller or Pluto Safety PLC which provides PL d.

### Mat Construction

The basic Mat construction consists of a ground plate of either PVC, Aluminium or Stainless Steel which provides protection against uneven ground etc. The Mat is made up of a sandwich construction, the pressure contact switch consisting of two conducting sheets separated from each other by a webbed isolating layer. The internal switching surface is cast into a durable polyurethane to protect against moisture, and this is then covered with a top layer of slip-free rubber mat or a thin aluminium plate.

Attachment to the floor is by means of a ramped edge trim or special profiles made of aluminium. The ramp profile has a channel for connection cables.

Custom Mats can be made, i.e. special shape, resistant against harsh industrial environments (mineral oil, acid, bleach etc.) or with a non-slip surface or M12-contacts.

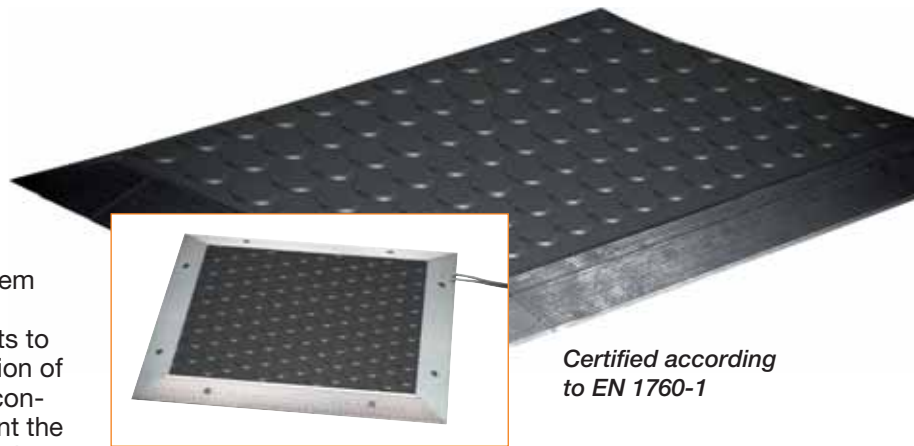

### Applications

- Personal protection within the dangerous areas around presses, robots, production lines, machines etc.

### Features

- Can be connected to a safety relay, Vital or Pluto
- Very durable
- IP 67

### Approvals

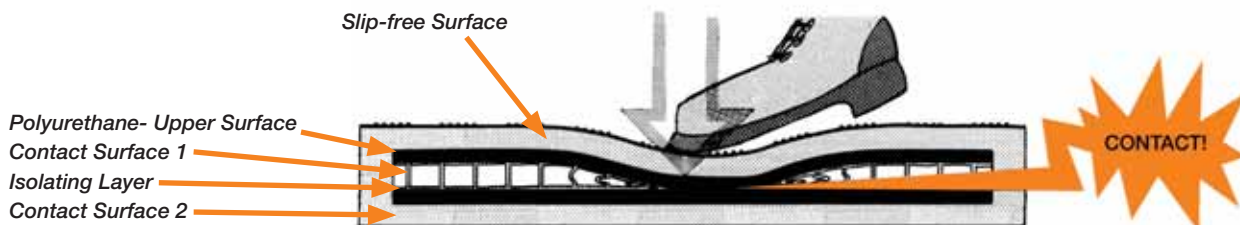



## Safety Mats Technical Data

Manufacturer	ABB AB/Jokab Safety, Sweden
Ordering information	see page 11:17
Max. area	Entire mat = 2350 x 1350 mm 10 m <sup>2</sup> (divided mat) Rec. relation max 3:1 Min 100x100 mm
Height	10mm without slip-free surface max 14.5 mm with slip-free surface
Inactive Area	Nominally 10 mm from Mat edge
Switching Force	150N (Round body 80mm)
Max. Pressure	2000 N over ø 80 mm
Material	Black polyurethane, other colours on request
Protection Class	IP 67
Ambient Air Temperature	0°C to +60°C

Chemical Resistance	
Oil, grease	good
10% acid	resistant
10% alkaline (caustic) solutions	resistant
Cable	2 x 5 m, 2 x 0,34 mm <sup>2</sup> , PU sheathed
Mechanical Life	> 1,5x10 <sup>6</sup> load shifting

## Edge Trim - Safety Mats

### Edge trim RS 14

Eliminates vertical edges and attaches the Safety Mat to the floor. Also provides protection and channel for connection cables.

### Profile BS14

Best for use on the side nearest the machine. Permits a shorter distance from, for example, a wall.

### Corner trim

Can be used between two RS 14 profiles as an alternative to miter cutting of profiles.

### ASK-1 T4.4-NP

Completely molded mat with molded edge profiles in PU.

### ASK-1U4.4-NP

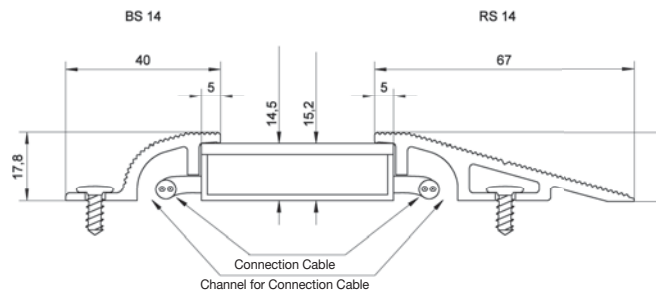

### Surface Protection

#### Fixing Profile

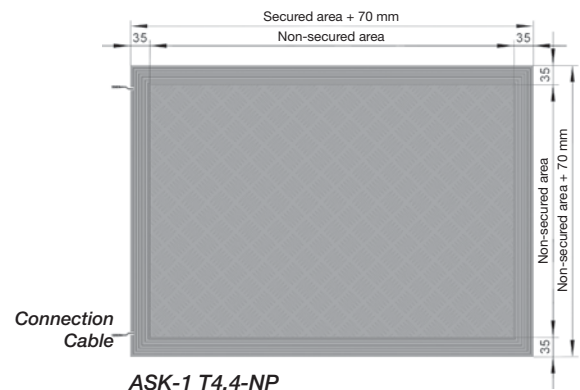
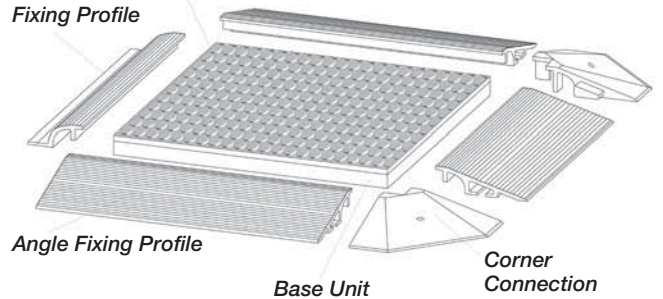

## Surface Layer - Safety Mats

Safety mats are normally supplied with a dotted polyurethane non-slip surface layer that withstands tough conditions very well (oil, acid or caustic substances) and has anti-slip properties. If required, other patterns can be supplied, or for special requirements even other materials, such as NBR rubber. Please contact us for more information about these alternatives.

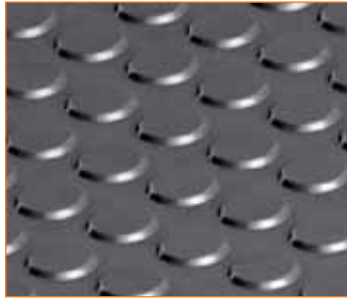

### Safety Distance - Safety Mat as Per EN ISO 13855

If a safety mat is used as entry protection, the smallest permitted safety distance between the hazardous area and the outer edge of the mat (seen from the hazard) is calculated using the formula from EN ISO 13855.

$$S = (K * T) + C$$

where

S = smallest permitted safety distance in mm

K = body speed (velocity of propagation 1600 mm/s)

C = additional distance in mm based on the intrusion of the body into the risk zone before the protection device is actuated (1200 mm)

i.e.

$$S = (1600 * T) + 1200$$

## Mounting - Safety Mats

The ground on which the mats are to be laid must be level, clean and dry. The mats should not be glued to the ground.

Place mat in required position with groundplate downwards. If more than one mat is to be installed be sure to place the mats edge to edge (without space).

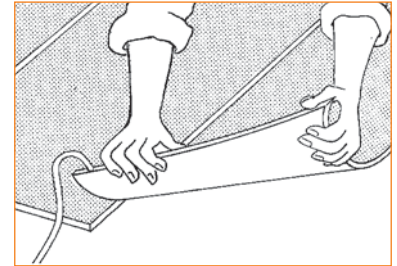

In the case of safety mats with cast-in rubber edge trim, the mat is secured to the floor by screws straight through the edge trim. In the case of safety mats with an aluminium edge trim, see below.

Place the selected edge trim to the mat. Edge trims are usually mitred (at 45 degrees) to provide complete protection around the corners of the mat.

Mark the cable routes on the edge trim and cut out slots to allow cable access into the cable channel as indicated. Connect the cables as shown under Electrical Connection.

Mark the locations of the securing screws along the scribed line on the edge trim. It is recommended that fixing screws should be located at 60 cm spacing.

Secure the edge trim to the ground with 6 mm plugs and suitable screws. Plug the holes above the screws in the edge trim with the cover plugs provided.

**NOTE: Safety mats must not be rolled/twisted or modified in any way. It is also essential that mats are not cut into any shape or shortened following delivery.**

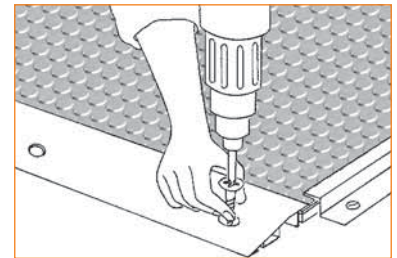

## Electrical Connection - Safety Contact Edges, Bumpers and Safety Mats

Contact edge, bumper or safety mat must be connected to a suitable monitoring unit (e.g. ABB Jokab Safety safety relays RT6, RT7A/B, RT9, Vital with Tina 6A or Pluto safety-PLC).

The monitoring unit monitors the functionality of the contact protection and detects any breaks or short-circuits in the lines. Several crush protection units can be connected in series while still retaining the same level of safety.

When pressure is applied, the active surface of the contact area in the contact protection is closed and

the safety output on the monitoring unit trips. A stop signal will be sent to the machine's safety circuits preventing any dangerous movements.

**Note: If alternative units are used rather than the recommended ABB Jokab Safety relays, it is essential that the user checks their suitability with ABB Jokab Safety before use. Failure to do so may result in incorrect operation and/or damage to the safety bumpers and invalidate warranty.**

## Connection Example

### HK7601A – Connection Contact Protection for Safety Relay RT6

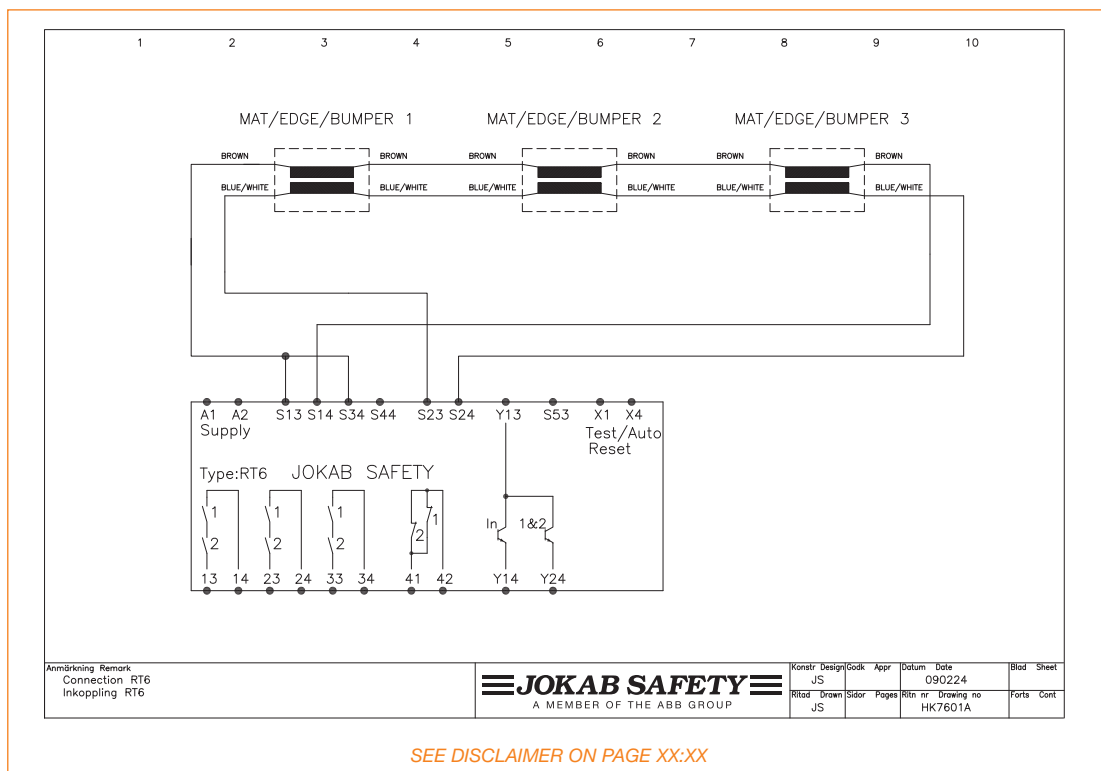

## Connection Example

### HK3310A – Connection Contact Protection for Safety Controller Vital 1

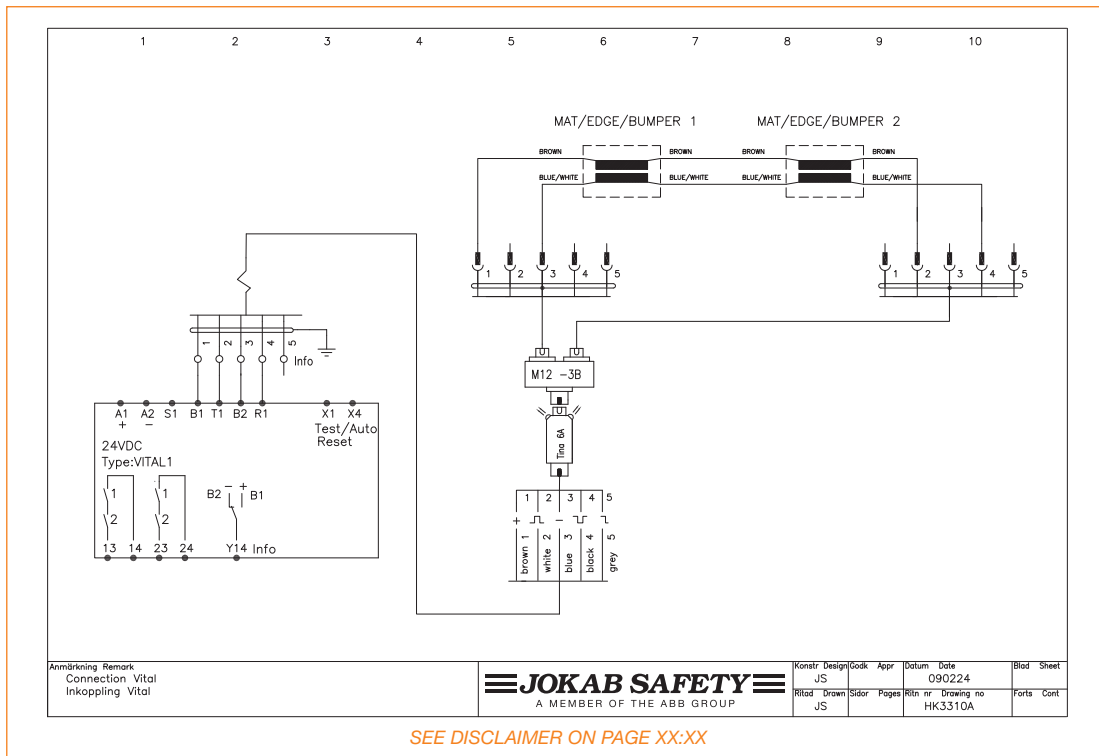

## Connection Example

### HK0001A – Connection Contact Protection for Safety PLC Pluto

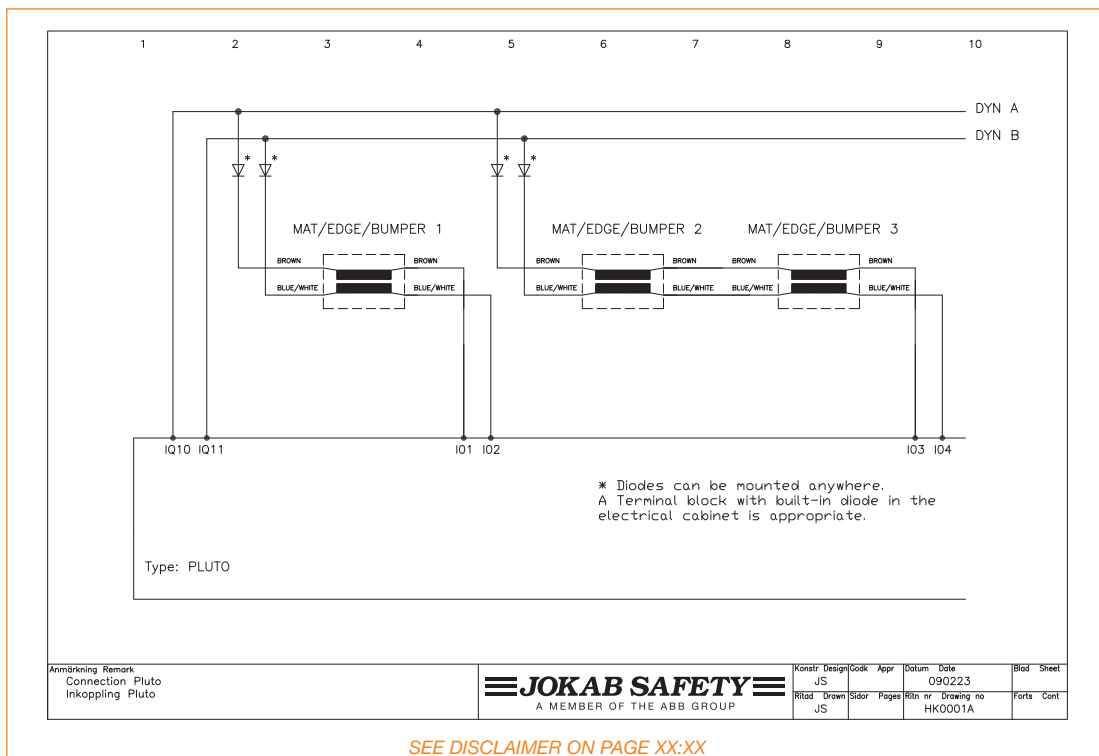

## Component List - Contact Edges

Designation	Ordering Information	Description
GP25/25 EPDM	2TLA076025R2500	GP – Contact edge including aluminium profile. Ordered by length.
GP25/25 NBR	2TLA076125R2500	GP – Contact edge including aluminium profile. Ordered by length.
GP25/40 EPDM	2TLA076025R4000	GP – Contact edge including aluminium profile. Ordered by length.
GP25/40 NBR	2TLA076125R4000	GP – Contact edge including aluminium profile. Ordered by length.
Cable* 2+2	2TLA076009R0100	2+2 m Cable, production cost. Please contact us for more alternatives.
Cable* 5+5	2TLA076009R0500	5+5 m Cable, production cost. Please contact us for more alternatives.
Cable* 7+7	2TLA076009R0800	7+7 m Cable, production cost. Please contact us for more alternatives.
Cable* 10+10	2TLA076009R1000	10+10 m Cable, production cost. Please contact us for more alternatives.
GE25-25 EPDM	2TLA076005R0200	GE – Contact edge per meter. Ordered by length.
GE25-45 EPDM	2TLA076005R0400	GE – Contact edge per meter. Ordered by length.
Cable	2TLA076005R4400	Connection plug with 2.5 m cable. Two pieces per edge.
	2TLA076005R4500	Connection plug with 5m cable. Two pieces per edge.
	2TLA076005R4600	Connection plug with 10m cable. Two pieces per edge.
	2TLA076005R4700	Connection plug with resistor 8.2K $\Omega$ . Two pieces per edge.
End Cap	2TLA076005R6100	End cap for GE25-45. Two pieces per edge.
	2TLA076005R6200	End cap for GE25-25. Two pieces per edge.
	2TLA076005R0000	End cap, Production cost GE (when ready made). Two pieces per edge.
	2TLA076005R6100	End cap for GE25-45. Two pieces per edge.

\* Note: Please contact us for more alternatives.

## Component List - Accessories for Assembly

Designation	Ordering Information	Description
Gluing Set	2TLA076005R7600	Gluing set for assembly.
Scissors	2TLA076005R8500	Scissors.
	2TLA076005R8600	Plug insert tool.

## Component List - Bumps

Designation	Ordering Information	Description
ASB Bumper	2TLA076200R0100	53/100 black.
	2TLA076200R0200	100/200 black.
	2TLA076200R0300	150/300 black.
	2TLA076200R0400	200/400 black.
	2TLA076200R0500	53/100 black/yellow.
	2TLA076200R0600	100/200 black/yellow.
	2TLA076200R0700	150/300 black/yellow.
	2TLA076200R0800	200/400 black/yellow.
	2TLA076200R0900	60/100 NBR black (63/100).
	2TLA076200R1000	100/200 NBR black.
	2TLA076200R1100	150/300 NBR black.
	2TLA076200R1200	200/400 NBR black.
	2TLA076200R1300	200/200 black.
	2TLA076200R1400	150/150 NBR black.
	2TLA076200R1500	100/200 NBR black/yellow.
	2TLA076200R1600	150/250 NBR black/yellow.
	2TLA076200R0000	Bumper base price.

## Component List - Mats

Designation	Ordering Information	Description
Cast Mat	2TLA076301R0000	ASK-1U4.4-NP. Production cost cast mat in PU with NP finish
	2TLA076301R0200	ASK-1T4.4-NP. Production cost cast mat in PU with NP finish and cast-in ramp edge trim.
	2TLA076301R0500	ASK-1U4.4-NP. No ramp edge trim, sq.m.
	2TLA076310R0600	ASK-1U4.4-NP. No ramp edge trim, 1000 x 1000 mm.
	2TLA076310R0700	ASK-1U4.4-NP. No ramp edge trim, 1000 x 1500 mm.
Edge Trim	2TLA076310R1000	ASK-1T4.4-NP. Cast-in ramp edge trim, 1000 x 750 mm.
	2TLA076310R1100	ASK-1U4.4-NP. No ramp edge trim, 1000 x 1000 mm.
	2TLA076310R1200	ASK-1U4.4-NP. No ramp edge trim, 1000 x 1500 mm.
	2TLA076301R0600	ASK-1U4.4-NP. No ramp edge trim, sq.m.
Edge Trim RS14	2TLA076300R0500	Eliminates vertical edges and attaches the safety mat to the floor. Also provides protection and channel for connection cables.
Profile BS14	2TLA076300R0800	Best for use on the side nearest the machine. Permits a shorter distance from, for example, a wall.
Corner Trim	2TLA076300R0900	Can be used between two RS 14 profiles as an alternative to miter cutting of profiles.
Cabling	2TLA076900R3200	Connection cabling including 1 off M8 male and 1 off M8 female, 2.5 m.
	2TLA076900R3300	Connection cabling including 1 off M8 male and 1 off M8 female, 5 m.

*\* Note: The above have a PU surface layer. Mats are available in any size and in other materials.*

This document and any attachments may include suggested specifications, drawings, schematics and similar materials from ABB Inc. Use of such information and/or documentation by the recipient is subject to and conditioned upon your acceptance of the terms of the General Document Disclaimer which can be found at [www.jokabsafety.com](http://www.jokabsafety.com). Your acceptance of the terms of such General Document Disclaimer is conclusively presumed unless you notify ABB in writing of your disagreement with the terms of such Disclaimer immediately upon receipt of this document and you return to ABB all specifications, drawings, schematics and similar materials provided to you by ABB.

Notes





# Quick-Guard® Safety Fencing Systems

Lightweight, flexible, economical!  
Easy to assemble or modify!  
All components are 100% recyclable!



- Quick-Guard Fencing Systems ..... 12:2
- A Flexible and Stable Fencing System  
which is Easy to Intall..... 12:3
- What do the standards say? ..... 12:4
- Quick-Guard is Supplied in Three Ways..... 12:6
- Quick-Guard E..... 12:7
- Quick-Guard S ..... 12:10
- Quick-Guard Standard and SafeCAD ..... 12:11
- Quick-Guard Standard Assembly ..... 12:12
- Aluminum Profiles ..... 12:14
- Fittings..... 12:19
- Door Components..... 12:22
- Fittings for Switches..... 12:32
- Terminal Caps and Strips ..... 12:35
- Accessories ..... 12:36
- Surfaces ..... 12:37
- Component List and  
Ordering Information ..... 12:39



# Quick-Guard® Fencing Systems

Flexible, stable and easy to install!

## Adaptation and Modification

Quick-Guard is a very flexible fencing system consisting of a minimum of different components, e.g. aluminum profiles, patented brackets, net-locks, mesh, solid or noise reduction panels. Using these components there are almost no limitations as to what can be built. Quick-Guard fencing costs little to assemble and modify.

## Assembly

Due to our patented screw-lock system, we can supply all brackets pre-mounted with fixing screws and nuts. No holes need to be drilled in the profiles and all cuts are made straight. This makes assembly and modification very easy.

## Two Versions of Quick-Guard

The Quick-Guard fencing system is available in two versions—Quick-Guard (Standard) and Quick-Guard Express—which also can be combined. The fencing systems are also easy to adjust when production equipment is modified and/or moved.

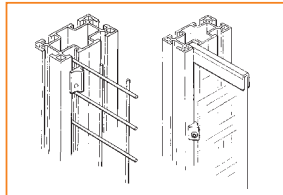

## Proposal and Ordering

By utilizing our AutoCAD® Mechanical Desktop based SafeCAD® program, we are able to make system designs in 3-D very quickly. Drawings, cutting lists, etc. are generated from SafeCAD and the drawings can also be used for installation purposes.

## Our policy is to create systems that are environmentally friendly and provide ergonomic working conditions

Quick-Guard is environmentally friendly. All components in the Fencing System can easily be disassembled and reused. All materials in the Fencing System are 100% recyclable. Quick-Guard can also provide a pleasing, ergonomic working environment.



Standard assembled with mesh.



Standard with black and transparent Polycarbonate in-fill panels as used for medical applications.



Quick-Guard E with few components and easy to angle at up to 20°.

## Advantages

- Brackets are supplied pre-mounted with screws and nuts
- Easy to adjust, assemble and modify
- Designed for various types of mesh, solid and noise reduction panels
- Short delivery time
- SafeCAD, a special program for designing fencing systems which automatically generates cutting lists

# A Flexible and Stable Fencing System which is Easy to Install

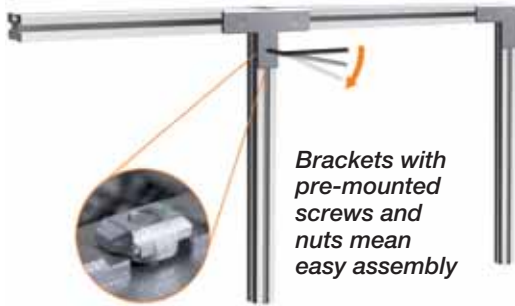

*Brackets with pre-mounted screws and nuts mean easy assembly*



*Depending on the application, some Quick-Guard doors can be designed to automatically open and close.*

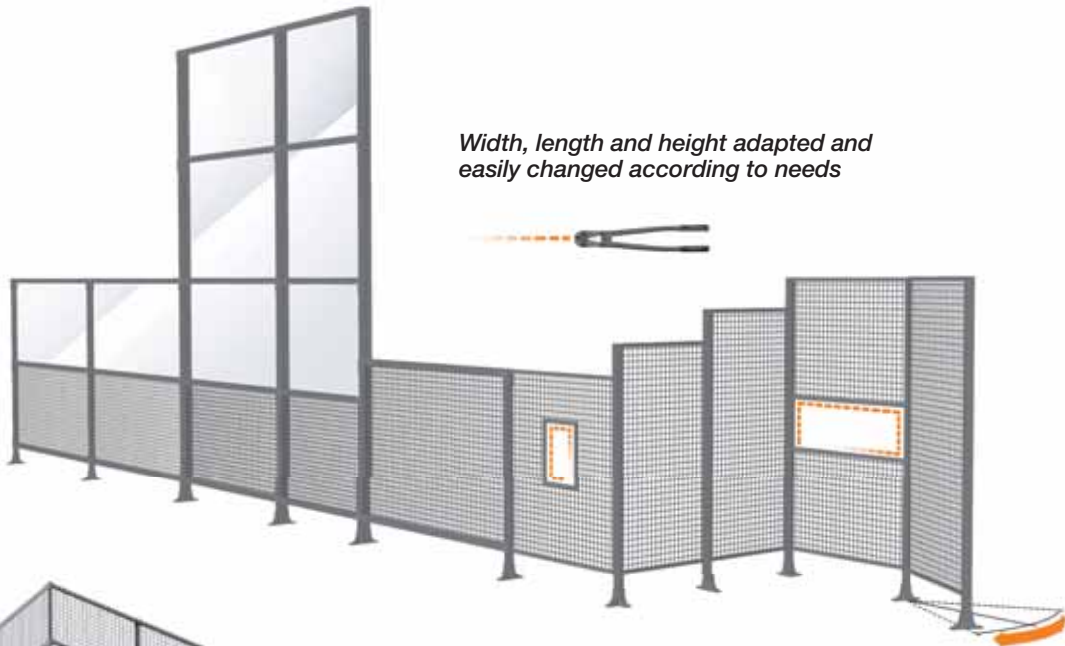

*Width, length and height adapted and easily changed according to needs*

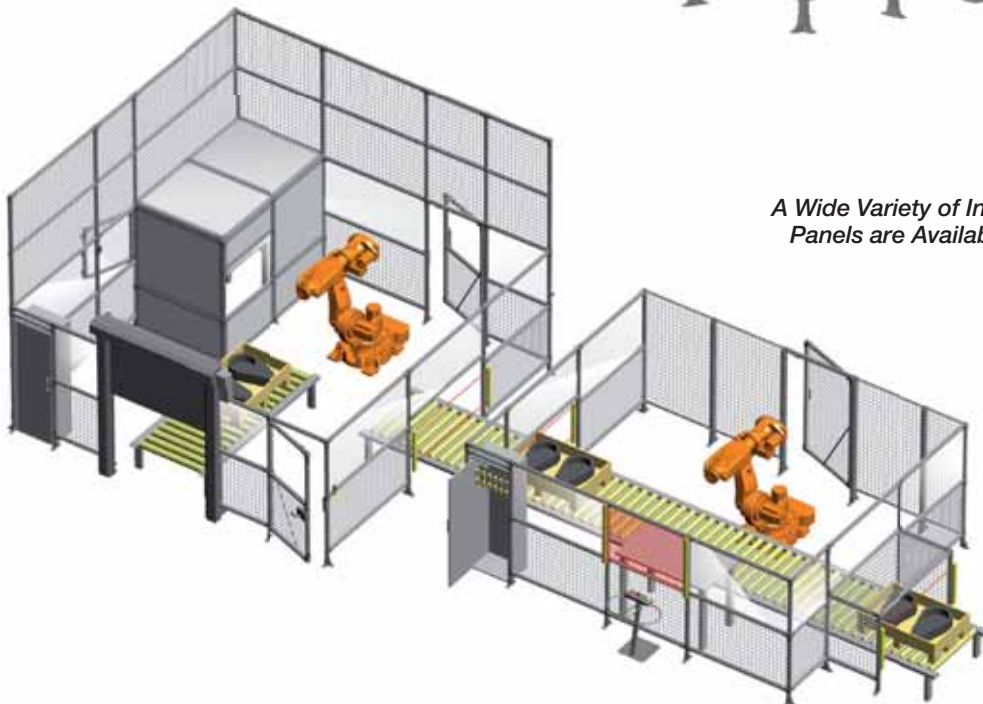

*A Wide Variety of Infill Panels are Available*

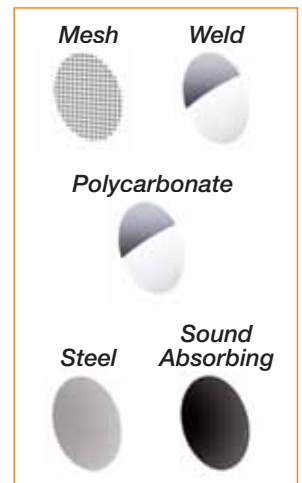

## What do the standards say?

The American National Standard for Machines, ANSI B11.19, provides information on acceptable safety distances in hazardous areas.

These figures give examples of the safety distances required for two different fencing heights, where the risk is considered to be low if somebody reaches into the hazardous area. If there is a risk of direct injury and/or if personnel can be dragged into the hazardous area the safety distances must be increased. For accepted heights and distances, please refer to ANSI B11.19, Annex D and other relevant standards/regulations.

When mesh is used, there must be a minimum distance of 45 mm for a mesh size of 40 x 40 mm. For shorter distances and for noise reduction, polycarbonate sheet should be considered.

When the fence shall protect, for example a robot cell, the fence should be placed with a minimum distance of 450 mm between the guard fence and the moving machine part which reaches the furthest—RIA 15.06 (1999). During verification and programming, there has to be space between the fence and moving parts to prevent the operator from being squeezed between them.

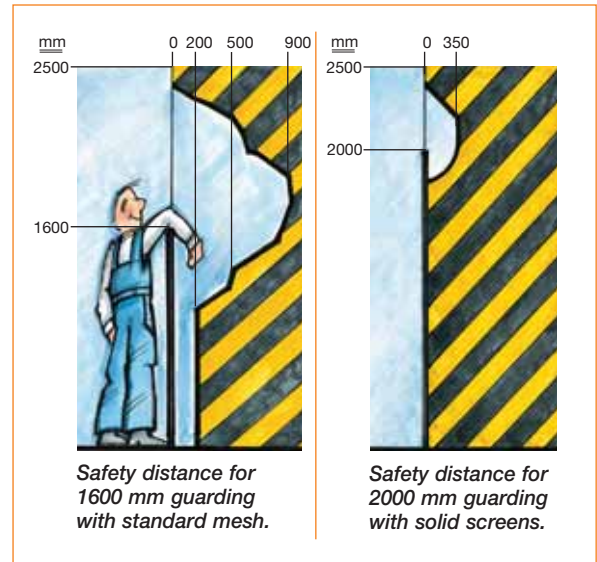

Safety distance for 1600 mm guarding with standard mesh.

Safety distance for 2000 mm guarding with solid screens.

ABB Jokab Safety will be pleased to advise on guarding design and safety distances required. Send requests for quotations to ABB Jokab Safety to [rfq@jokabsafetyna.com](mailto:rfq@jokabsafetyna.com)

## Quick-Guard Fencing Meets Requirements

Quick-Guard is a fencing system which is designed to manage the requirements from a safety perspective. It manages to stop machine parts and material that, during a malfunction, can be thrown against the fence. We have made some collision tests with a large industrial robot, ABB Irb 6600, which was driven into the fence at a pace of 3 m/s. Both our Quick-Guard Standard and Express fencing systems withstood this impact. Thanks to our patented net-lock, both mesh and polycarbonate panels remained firmly attached to the aluminum profile. A video showing these tests is available on our website. In our tension tests of up to

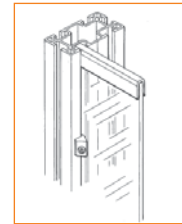
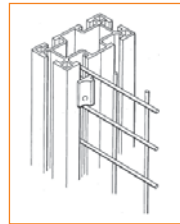

In our pulling tests of up to 500 kg, both mesh and polycarbonate panels remain firmly in the Quick-Guard profile.

500 kg, both mesh and polycarbonate also remained firmly in the aluminum profiles. The fence was deformed during the collision, but it sprung back, with minimal deformation as a result.

## Patented Assembly Function

The ABB Jokab Safety patented guide and locking method makes it simple to assemble and dismantle the fencing system. The nut has several advantages, it can easily be located into the profile and automatically positions itself when the screw is turned 90 degrees clockwise. When in this position the bracket being mounted can be adjusted as required and locked by turning the screw further clockwise. To remove the bracket the fixing screw is turned counterclockwise until the nut is in line with the profile slot.

Mount the fixtures by first slackening the screw 3/4 turn counterclockwise. Then tighten the screw clockwise in the usual way. The nut will then automatically mechanically lock the fixture into the profile.

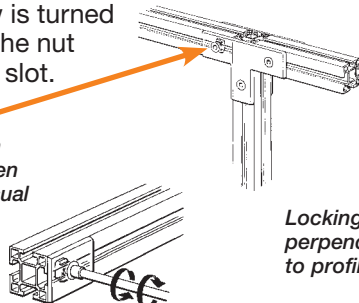

Centralizing and turning limitations

Locking perpendicular to profile slot

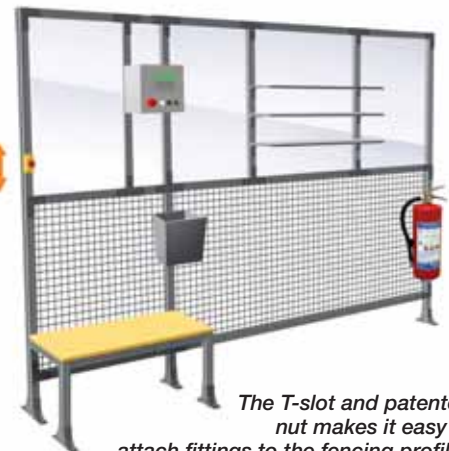

The T-slot and patented nut makes it easy to attach fittings to the fencing profiles or to adjust the position of fittings.

All fittings are supplied Preassembled. Fittings that do not have a cast-in tab can be provided with a centering washer.

## ANSI/RIA R15.06-1999 - Slotted Opening Minimum Distance from Hazard

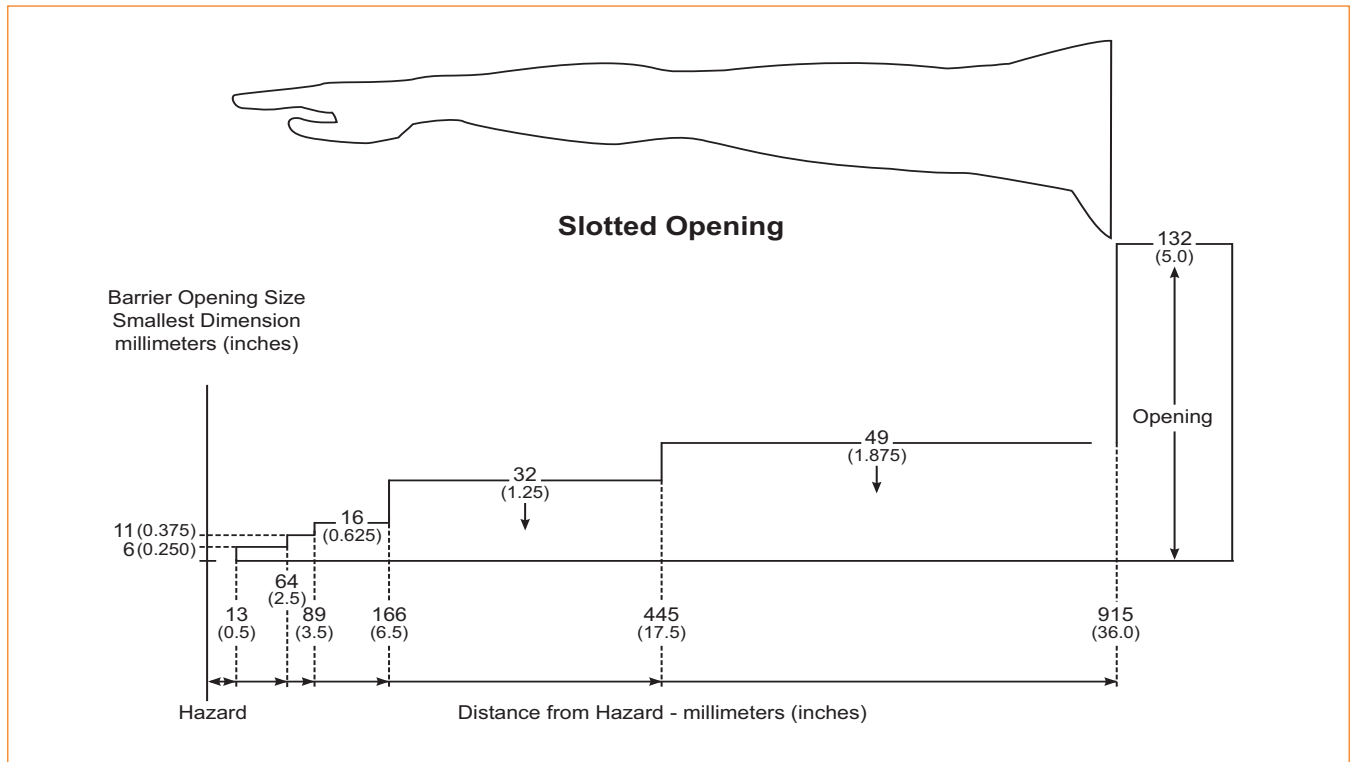

## Square Opening Minimum Distance from Hazard

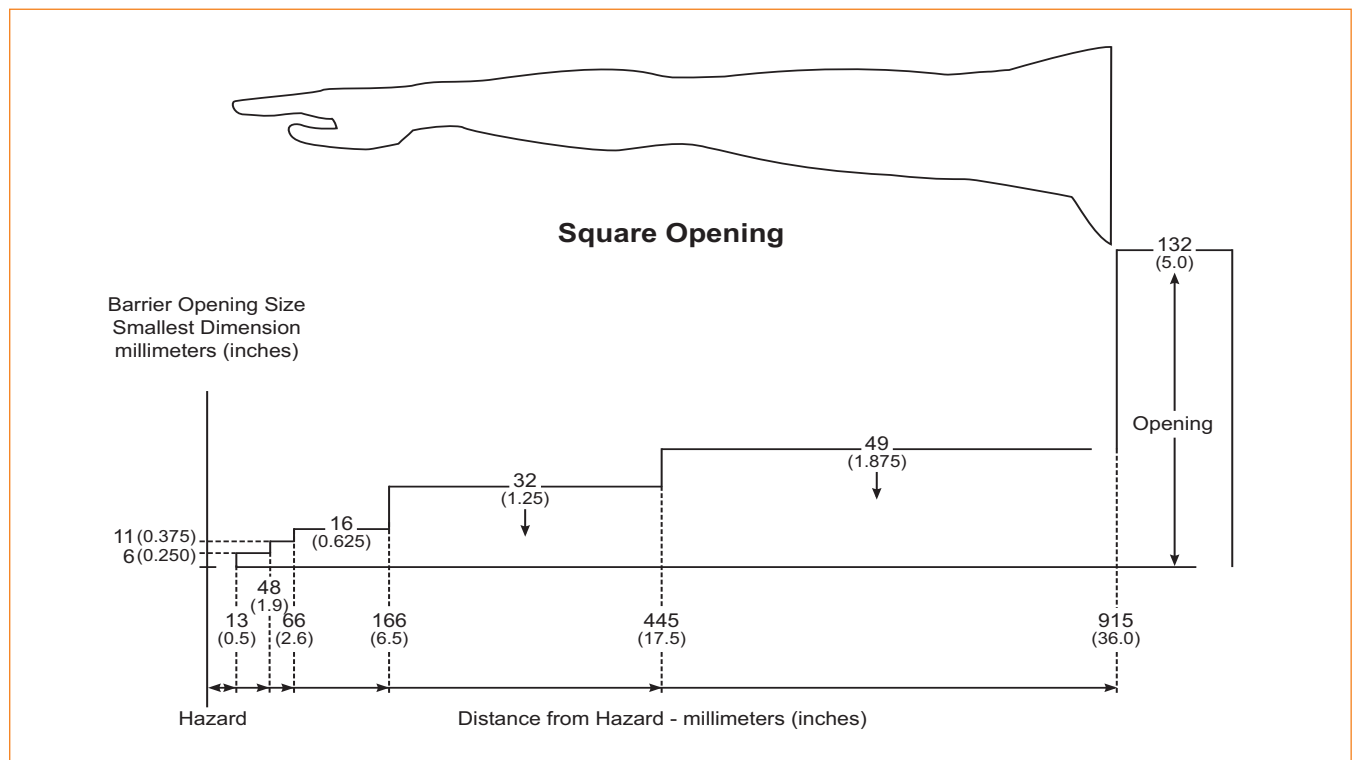

Send requests for quotations to [rfq@jokabsafety.com](mailto:rfq@jokabsafety.com)

# Quick-Guard® is Supplied in Three Ways

## 1 To Be Designed on Site

You only order sections consisting of a few components. Then the fencing system is built on site. A manual mesh clipping tool, for easy cutting of the mesh, is provided with the delivery if needed. The profiles are easily cut with a crosscut saw. The advantage of using aluminium is that it is not flammable when cut—compared to iron which requires a fire-watcher in many industries.



## 2 Cut to Size according to Drawing

You just give us a simple sketch or an AutoCAD® file of how you want the fencing system to look. We input this information into SafeCAD and design the fence in 3D. From this drawing, cutting and component lists and a quotation are generated automatically.

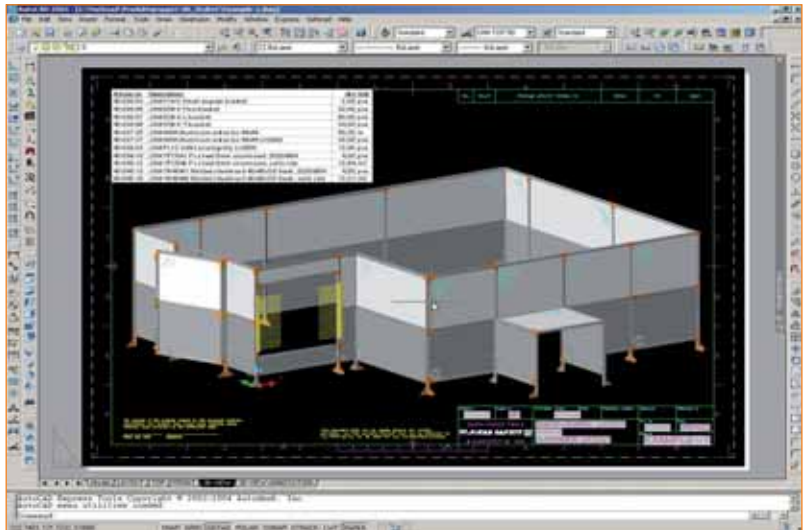

## 3 Pre-Mounted/Assembled on Site

We can deliver full/partially pre-assembled fencing systems or we can assemble them on site.



## Quick-Guard® E - Design Directly on Site

Quick-Guard E is installed quickly and cost effective because it only consists of patented net-locks, welded mesh, panels of polycarbonate, u-profiles and fence posts (profiles with floor-brackets).

All parts for Quick-Guard and Preassembled doors are delivered immediately from stock. The few components of the fencing system make it easy for you to custom build and install the fencing system yourselves.

The strength of the fencing system originates from the fact that the welded mesh and/or panels of polycarbonate are 'locked' into the profile. The outer wire of the mesh is locked by uniquely designed 'net-locks' into the profile making the fixing virtually as strong as being welded. The polycarbonate panels are locked in with specially designed infill-locks which, according to our tests, have been as strong as the mesh net-lock system. If you want more stable fencing posts, you can choose a sturdier profile measuring 44 x 88 mm instead of the standard 44 x 44 mm profile.

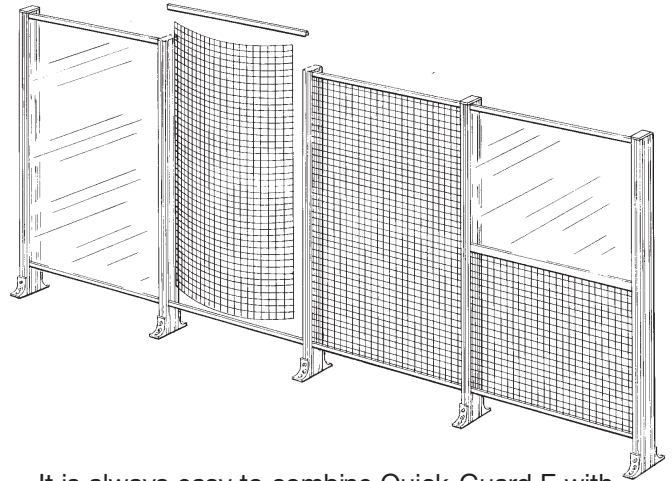

It is always easy to combine Quick-Guard E with Quick-Guard standard to achieve a complete system. It is also easy to adjust and modify the guarding system when production equipment is modified and/or moved.

### Assembly of Quick-Guard E

**1** Premount floor fixtures on vertical posts. Mount fixtures by first slackening the screw counter-clockwise. Then tighten the screw clockwise in the usual way, the nut will then automatically locate into the correct position and mechanically lock the fixture into the profile. Make sure that the nut has turned correctly.

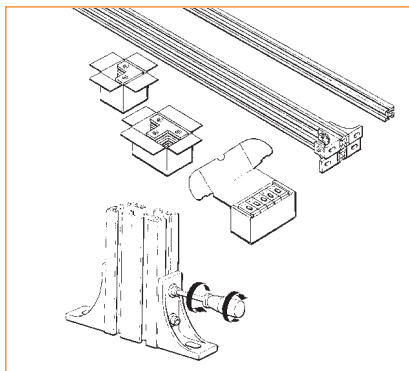

**2** Assemble the next section. The distance between the posts can be adjusted some mm after the mesh is locked in with the Net-locks. The mesh can be angled up to 20° without using hinges (JSM 35-K).

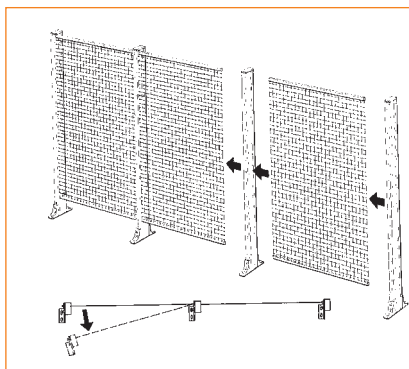

**3** Step 1: Insert spacer screw into the post profiles.

Step 2: Place the lower u-profile on the mesh.

Step 3: Push the mesh into the profile and fix the mesh with NL2 net-locks.

Step 2: Fix top u-profile in place either before or after inserting the mesh.

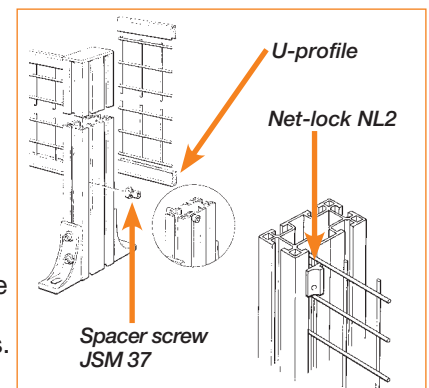

**4** Lock the top of the mesh using NL3 net-locks; this way the mesh is secured, stabilized and electrically grounded.

*Note: Grounding is needed when electrical devices or cables are assembled on the mesh.*

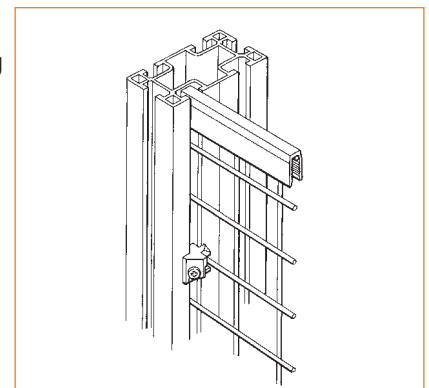

## Quick-Guard® E - Can Be Ordered in Sections

Quick-Guard Express can be ordered in different sections consisting of a few components. By adding the different sections, one can easily build a guard fencing system.

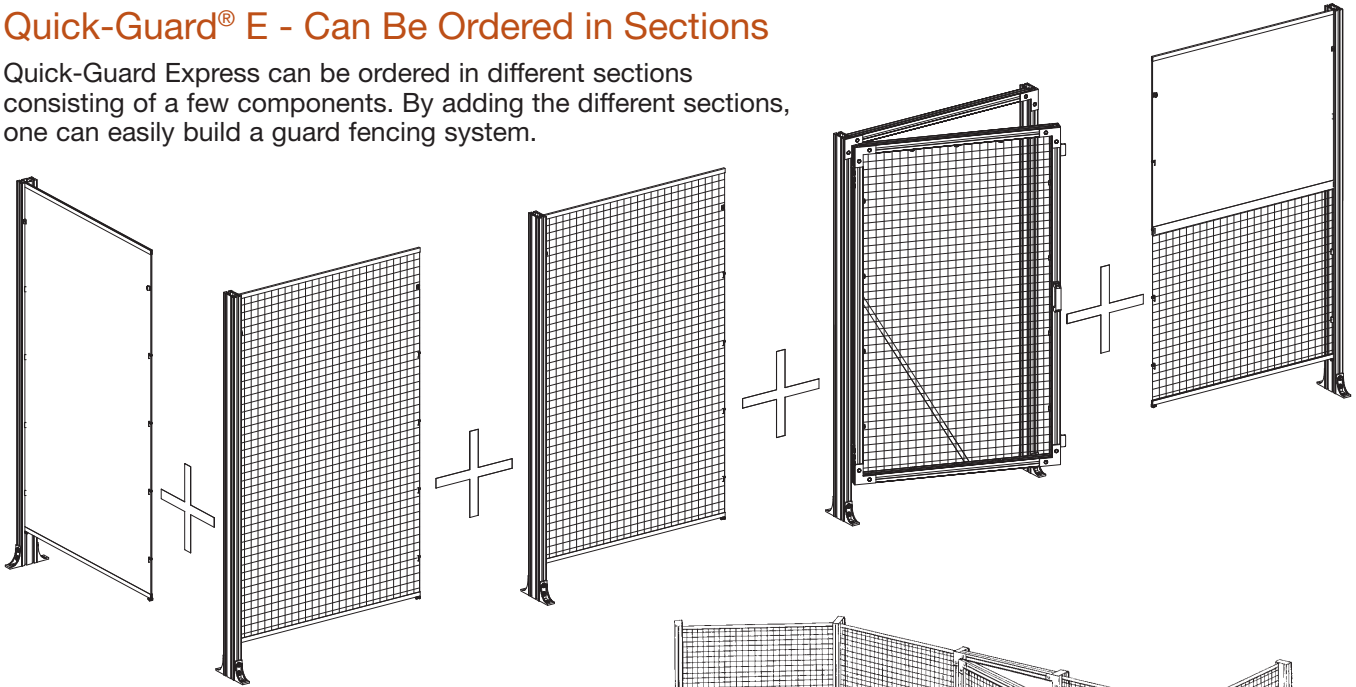

One can easily assemble the Express sections. It is also possible to angle these sections (20°). The mesh can easily be cut to the desired size with a simple clipping tool.

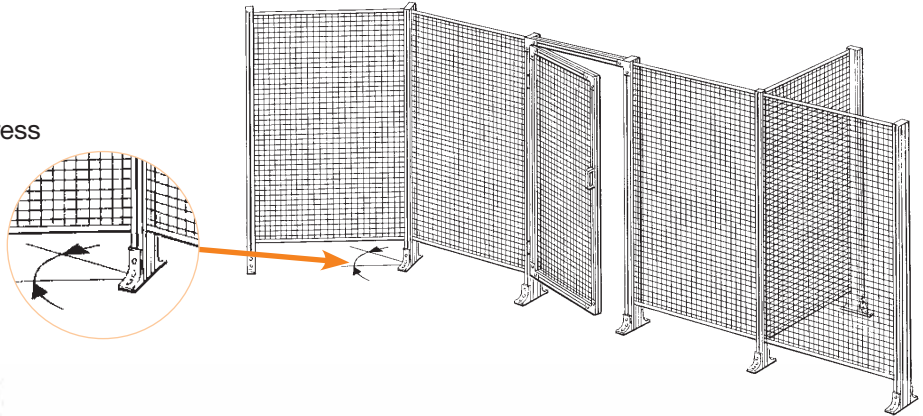

Measure the number of meters of fencing that are required and determine the number of doors. Our two standard sections have a center-to-center width of 1100 mm and 1500 mm. The opening width of the doors is 934 mm (36.0") and can be placed anywhere along the fence line.

If dimensions other than the standard dimensions are needed, just cut the mesh to the correct size with a bolt cutter.



## Quick Guard E

Quick Guard E can be ordered in different sections consisting of a few components. By combining the different sections, one can easily build a complete fencing system. You can order Quick-Guard E by part number, or contact the office for an estimate of your

fencing requirements. Quote lead time for Quick-Guard E is same day, and orders are often shipped the same day a purchase order is received. Consult the charts below to find the section that suits your needs.

### Vertical Posts

Post sizes for Quick-Guard E sections are either 44x44mm or 44x88mm. Each post comes with one yellow end cap, one mesh support screw, two floor brackets and six net locks. Posts come unassembled. Part numbers for each width can be found in the chart.

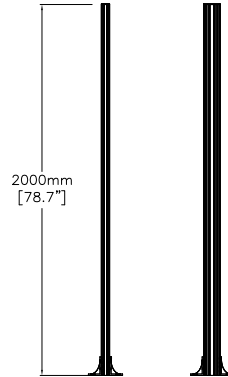

Post Width	Post Height	Part Number
44 x 44mm	2000mm	2TLA858000R9800
44 x 88mm	2000mm	2TLA858000R9900

### Fence Section

Panel widths are all from center to center of vertical posts. Each panel comes with the aluminum u-channel assembled, and with net locks to secure both sides of the mesh to vertical posts. Part numbers for each panel can be found in the chart.



Panel Width (center to center)	Part Number
1100mm	2TLA858001R0000
1500mm	2TLA858001R0100

### Hinged Door

Door widths are measured from inside to inside of each vertical post. Each door comes with all required hardware (frame, brackets, crossbar, handle, hinges, stops and magnetic catch) shown in the drawing to the right. Doors panels come assembled. Part numbers for each width can be found in the chart.

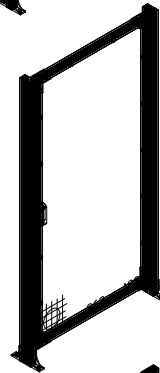

Hinged Door Panel (opening size)	Part Number
934mm (36")	2TLA858001R0200

### Sliding Door

Door widths are measured from inside to inside of each vertical post. Each door comes with all required hardware (frame, brackets, handle, hinges, stops and ball catch) shown in the drawing to the right. Door panels come assembled. Part numbers for each width can be found in the chart.

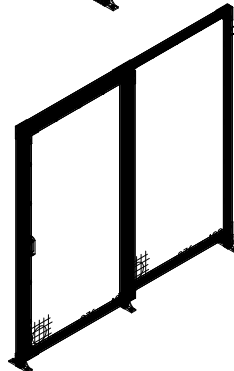

Sliding Door Panel (opening size)	Part Number
934mm (36")	2TLA858001R0300

## Quick Guard S

Quick Guard S can be ordered in different sections consisting of a few components. By combining the different sections, one can easily build a complete fencing system. You can order Quick-Guard S by part number, or contact the office for an estimate of your

fencing requirements. Quote lead time for Quick Guard S is same day, and orders are often shipped the same day a purchase order is received. Consult the charts below to find the section that suits your needs.

### Vertical Posts

Post sizes for Quick Guard S sections are either 44x44mm or 44x88mm. Each post comes with one yellow end cap, one mesh support screw, two floor brackets and six net locks. Posts come unassembled. Part numbers for each width can be found in the chart.

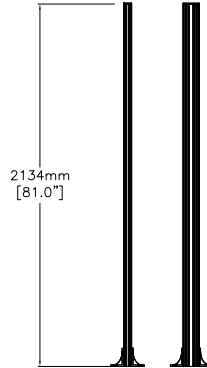

Post Width	Post Height	Part Number
44 x 44mm	2134mm	2TLA858001R0400
44 x 88mm	2134mm	2TLA858001R0500

### Fence Section

Panel widths are all from outside to outside of vertical posts. Each panel comes fully assembled with all necessary hardware. Part numbers for each panel can be found in the chart.

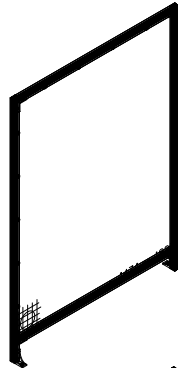

Panel Width (center to center)	Part Number
584mm	2TLA858001R0600
793mm	2TLA858001R0700
1542mm	2TLA858001R0800

### Hinged Door

Door widths are measured from inside to inside of each vertical post. Each door comes with all required hardware (frame, brackets, crossbar, handle, hinges, stops and magnetic catch) shown in the drawing to the right. Doors panels come assembled. Part numbers for each width can be found in the chart.

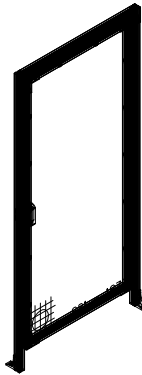

Hinged Door Panel (opening size)	Part Number
934mm (36")	2TLA858001R0900

## Quick-Guard® Standard and SafeCAD®

Quick-Guard consists of a minimum of different components, such as aluminum profiles, patented assembly parts, net-locks, mesh, solid or noise reduction panels. Furthermore the cost for assembly and modification of the system is low. Thanks to our patented screw-lock system, we can supply all brackets pre-mounted with fixing screws and nuts. No holes need to be drilled in the profiles and all cuts are made straight. Assembly and modification is therefore very easy.

To be able to quickly and easily custom design practical safety solutions, we have developed a computer program, SafeCAD. This is a 'plug-in' program for AutoCAD®. A simple sketch of the guarding system that is required is used as the program input. The positions of doors and hatches, choice of mesh, polycarbonate, aluminum/steel sheet or noise reduction panels are typed in. The program automatically generates 3D drawings along with component and cutting lists.

These drawings are also used as the basis for assembly / installation.

It is always easy to combine Quick-Guard Express with Quick-Guard to achieve a complete system. It is also easy to adjust and modify when the production equipment is modified and/or moved.

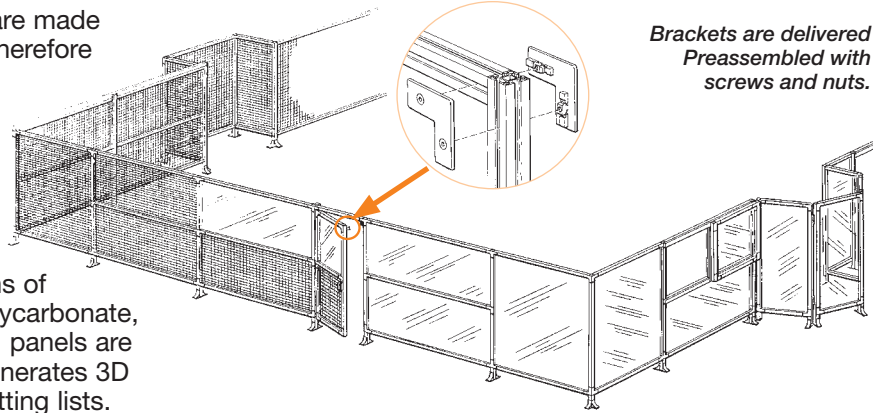

## Using SafeCAD® makes it easy for ABB Jokab Safety to help you customize the Safety Solution for your needs!

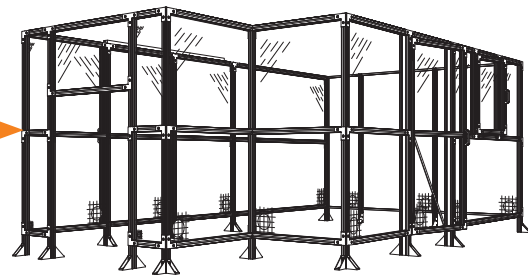
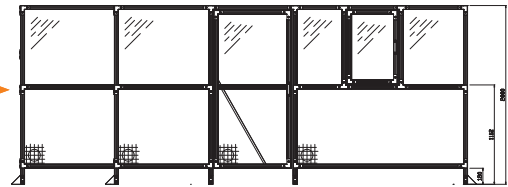

Example of component and cutting list print-outs from SafeCad.

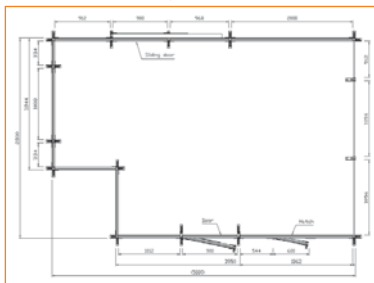

Quote				Qty	Unit
Article no	Description				
40-030-06	JSM 30B-K Floorbracket		26,00	pcs	
40-030-07	JSM 32B-K L-bracket		72,00	pcs	
40-030-08	JSM 33B-K T-bracket		18,00	pcs	
Cutlist Polycarbonate					
Article no	Description	Qty	Length	Width	Sum m <sup>2</sup>
40-039-10	JSM YPC5A1 Pc sheet 5mm uncoloured 2020x864	1	864	2020	1,75
40-039-12	JSM YPC5A9 Pc sheet 5mm uncoloured, cut to size	1	532	1020	0,54
40-039-12	JSM YPC5A9 Pc sheet 5mm uncoloured, cut to size	1	756	504	0,38
Cutlist Welded Mesh					
Article no	Description	Qty	Length	Width	Sum m <sup>2</sup>
40-040-13	JSM YN40W1 Welded steelmesh 40x40x3,5 black, 2020x864	1	864	2020	1,75
40-040-14	JSM YN40W2 Welded steelmesh 40x40x3,5 black, 1074x1816	2	1820	1074	3,91
40-040-16	JSM YN40W9 Welded steelmesh 40x40x3,5 black, cut to size	2	864	354	0,61
40-040-16	JSM YN40W9 Welded steelmesh 40x40x3,5 black, cut to size	1	864	804	0,69
40-040-16	JSM YN40W9 Welded steelmesh 40x40x3,5 black, cut to size	1	864	920	0,79

## Quick-Guard® Assembly, Standard Version

Assembly of the Quick-Guard® system is very easy. All components are very light in weight and ergonomic in design. This enables, in most cases, one man to be able to assemble both simple and complex structures with ease using very few different types of fixing components. All fixtures can be mounted easily from “outside” by using the specially designed “locking nut” which can be located anywhere in the extrusion channel. The fixture components, by means of integral locating keys, ensure that correct angles are achieved and enable the number of bolts/nuts to be reduced to half the number that would otherwise be required.



**1** Premount floor fixtures by first slackening the screw counterclockwise. Then tighten the screw clockwise in the usual way. The nut will then automatically locate into the correct position and mechanically lock the fixture into the profile.

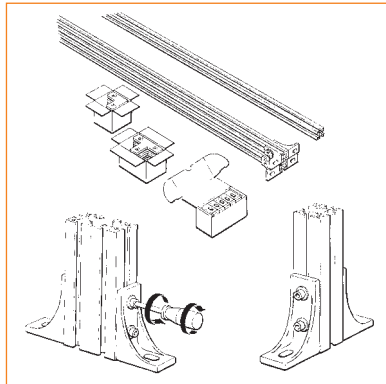

**2** Attach lower horizontal extrusion between vertical posts. Use a spacing block to ensure the correct distance from the floor.

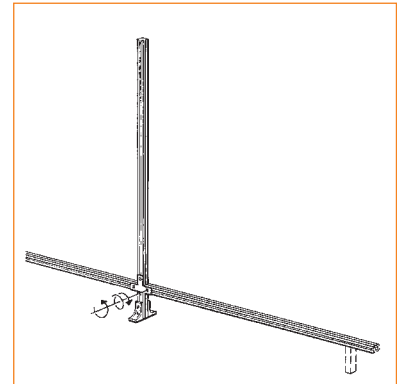

**3** Insert infill panel and fix middle horizontal profile. The distance between the profiles is the width of the infill minus 20 mm.

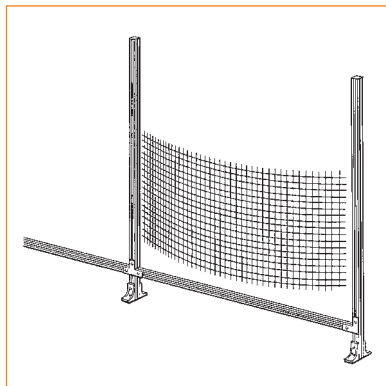

**4** Insert top infill panel. Fix top profile with fittings on the top on both sides.

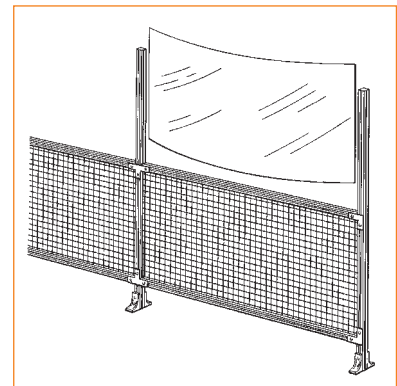

**5** Fix the poles to the floor.

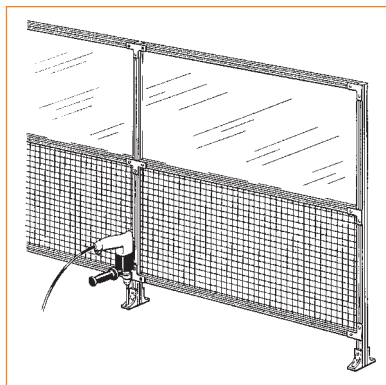

**6** Secure infill sheet with plastic strip or Net-lock fixings. Easy, fast and quick. See more under Assembly of netlocks. If there is a risk of the robot striking the polycarbonate, JSM PL3 panel locks must be used.

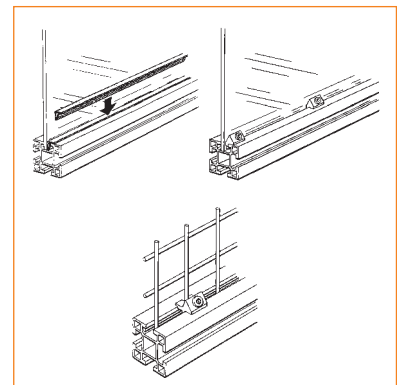

## Assembly using NL2 and NL3 Net-locks on Welded Mesh

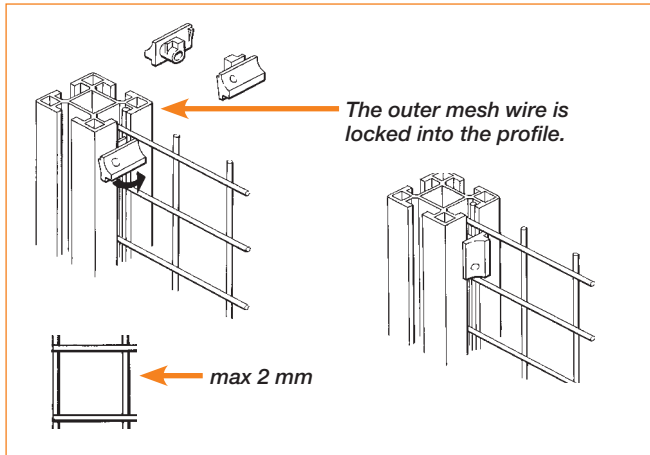

### NL2 Net-lock

When assembling the Net-lock NL2 it is first put into the profile as the drawing shows. Then the Net-lock is turned 90°. When cutting the welded mesh the wire ends should not be longer than two (2) mm.

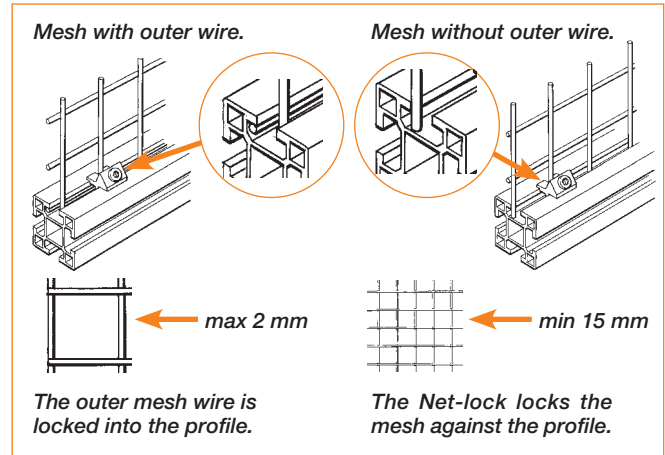

### NL3 Net-lock

When assembling the Net-lock NL3 it is first put into the profile with the tabs on each side of the mesh wire. The screw is then tightened. When cutting the welded mesh the wire ends should be at least 15 mm to fit into the profile. NL3 must be used to lock the mesh into the slot.

## Number of Net-locks

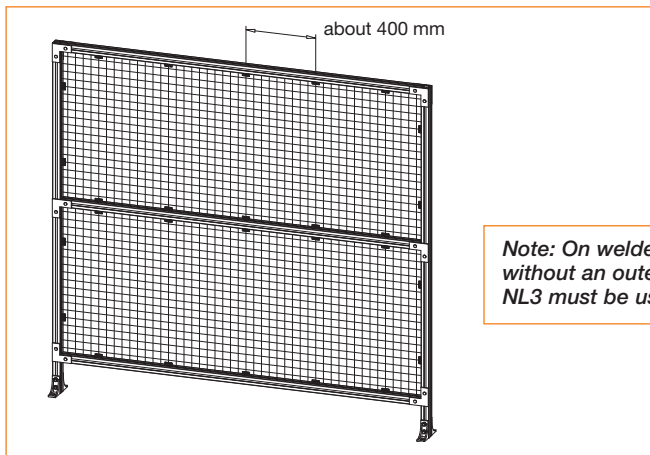

### Quick-Guard Standard Version

On Quick-Guard standard version NL3 is recommended as it can handle mesh with and without an outer wire.

**Note: On both Quick-Guard Standard and Quick-Guard E at least two NL3 should be used in order to mechanically lock the mesh and to electrically ground the mesh. NL3 should only be used on doors.**

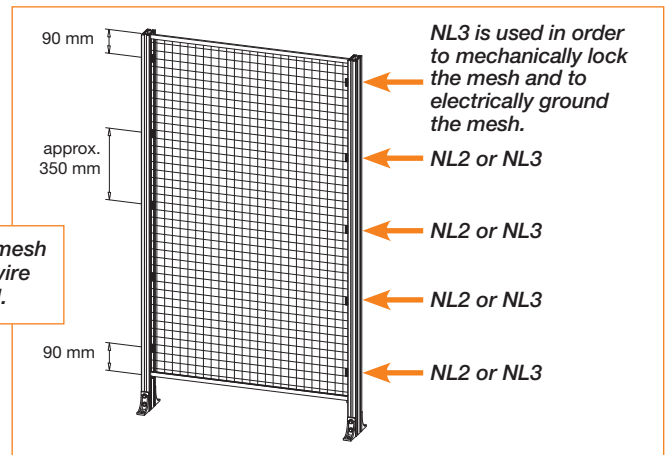

### Quick-Guard E Version

On Quick-Guard E both Net-lock NL2 and NL3 can be used. For mesh edges without outer wire NL3 must be used instead of NL2.

## Fixing posts to the floor when mesh is required to be fitted at a later date—

Temporarily mount at least two middle profiles before drilling and fixing posts to the floor. This method is used when infill mesh or panels are to be fitted at a later date.

**Note: Never attempt to fix the posts to the floor without first connecting at least two middle profiles to ensure the posts are parallel to each other and vertical.**

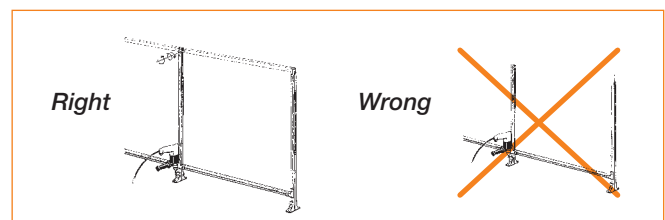

## Dimensions for Aluminum Profile Lengths and Panels

Material	Width	Height
Polycarbonate	X+20 mm	Y+20 mm
Welded mesh	X+20 mm	Y+20 mm
Steel panel	X+20 mm	Y+20 mm
Sound-absorbing panel 25mm	X-37 mm	Y-37 mm
Sound-absorbing 50 mm	X-37 mm	Y-37 mm
Laminated glass	X+15 mm	Y+15mm
Double Pc	2 pcs. X-7	2 pcs. Y-7
Sound absorbent panel profile JSM AS1	2 pcs. L=X	2 pcs. L=Y-73
Sound-absorbing profile JSM AS3	2 pcs. L=X (mitred 2 x 45 degrees)	2 pcs. L=Y (mitred 2 x 45 degrees)
Double Pc profile JSM AS2	2 pcs. L=X	2 pcs. L=Y-33

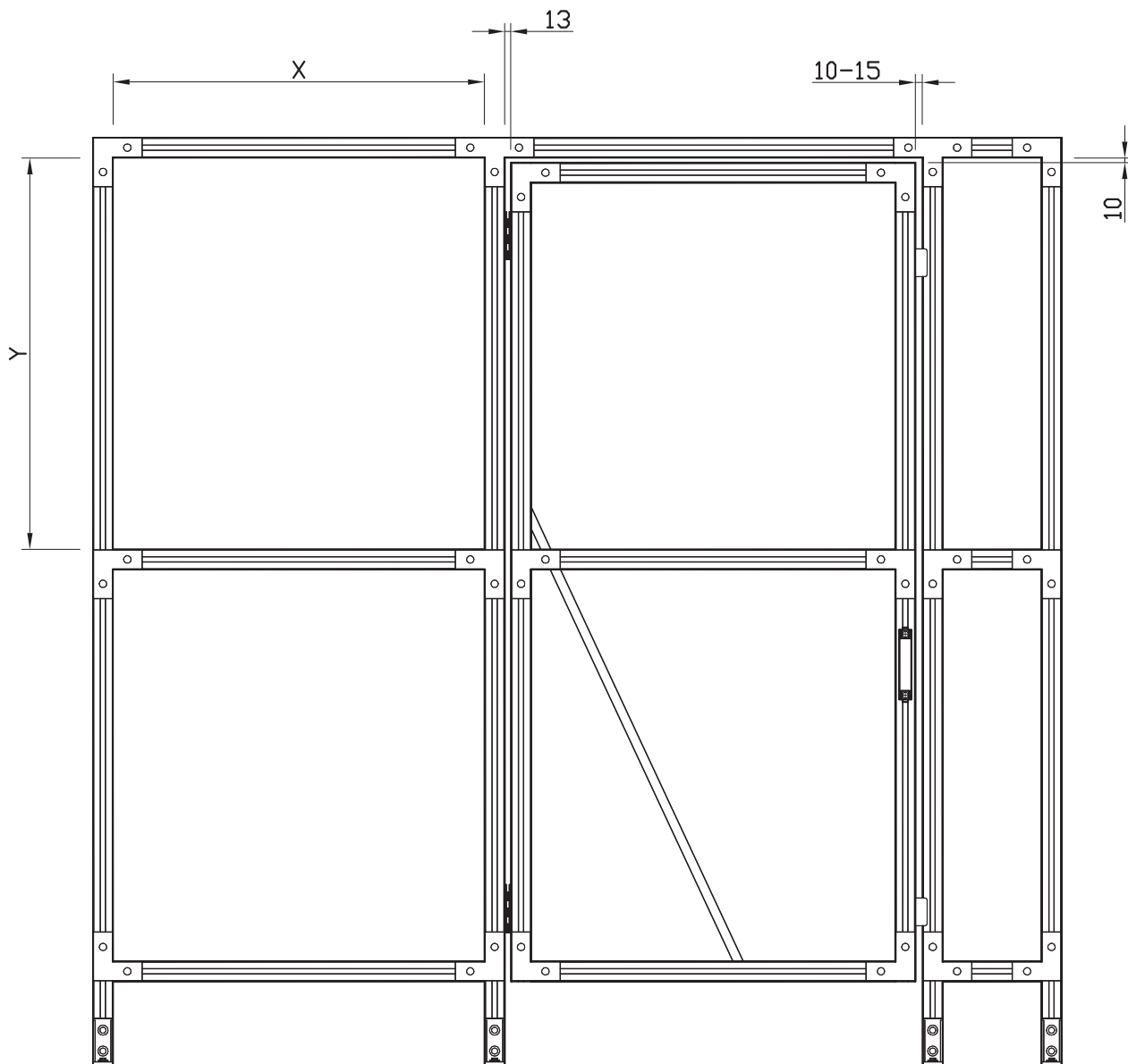

## Aluminum Profiles

A wide range of aluminium profiles are available and include, fencing profile, guide rails, and cable ducting. The cable ducting is available in three sizes. The cable ducting is easy to open and can be provided with end caps. Cover strips of plastic are also available, inclu-

ding fencing profiles making the entire groove cross section utilisable as 'installation conduit' for cables. The Aluminium profiles have integral "V" grooves to aid in centering any drilling that may be necessary.

## Fencing Profile

Designation	JSM A4416
Ordering information	2TLJ040037R7400 (ordered in meters)
Material	Naturally anodized aluminum
Dimensions	16.5 x 44 mm

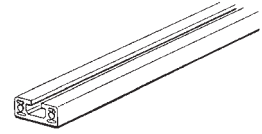
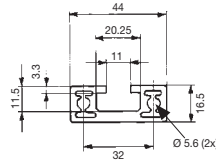

Designation	JSM A4426
Ordering information	2TLJ040037R8100 (L = 6000)
Material	Naturally anodized aluminum
Dimensions	44 x 26 mm

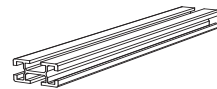
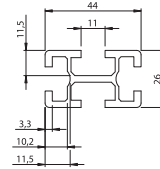

Designation	JSM A44A
Ordering information	2TLJ040037R3700 (L = 2000) 2TLJ040037R4100 (L = 6000)
Material	Naturally anodized aluminum
Dimensions	44 x 44 mm
Ordering unit	10 pcs / box

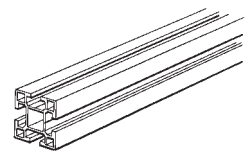
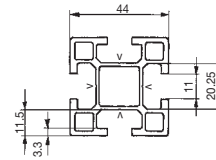

Designation	JSM A4488A
Ordering information	2TLJ040037R4300 (L = 2000) 2TLJ040037R4500 (L = 6000)
Material	Naturally anodized aluminum
Dimensions	44 x 88 mm
Ordering unit	5 pcs / box

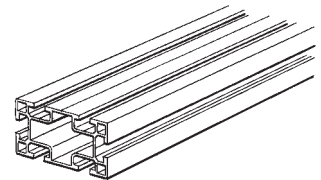
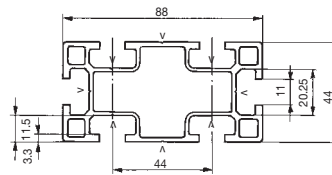

Designation	JSM A8888
Ordering information	2TLJ040037R7900 (L = 6000)
Material	Naturally anodized aluminum
Dimensions	88 x 88 mm

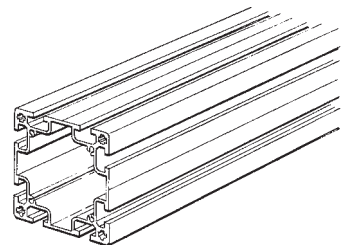
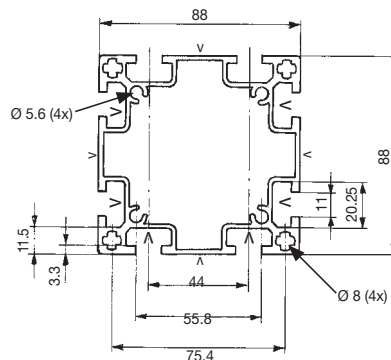

*Note: All fencing profiles can be ordered in meters. Ask your ABB Jokab Safety representative for more information.*

## Fencing Profile - Technical Data

Type	Weight (kg/m)	Angular moment		Flexural resistance	
		$I_x$ (mm <sup>4</sup> x10 <sup>4</sup> )	$I_y$ (mm <sup>4</sup> x10 <sup>4</sup> )	$W_x$ (mm <sup>3</sup> x10 <sup>3</sup> )	$W_y$ (mm <sup>3</sup> x10 <sup>3</sup> )
JSM A4416	1.040	1.1	7.6	1.19	3.43
JSM A4426	1.023	3.2	7.4	2.47	3.36
JSM A44A	1.504	12.4	12.4	5.64	5.64
JSM A4488A	2.379	79.6	21.6	18.1	9.8
JSM A8888	3.632	143.0	143.0	32.5	32.5

### Fencing U-Profile

Designation	JSM A12
Ordering information	2TLJ040037R2700 (L = 1076) 2TLJ040037R4600 (L = 1476) 2TLJ040037R4700 (L = 2000)
Material	Naturally anodized aluminum
Weight	0.230 kg/m

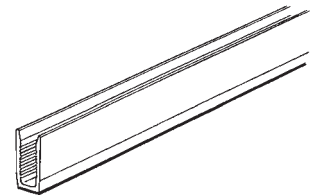
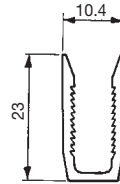

### Fencing H-Profile

Designation	JSM A13
Ordering information	2TLJ040037R5300 (L = 2020)
Material	Naturally anodized aluminum
Weight	0.452 kg/m

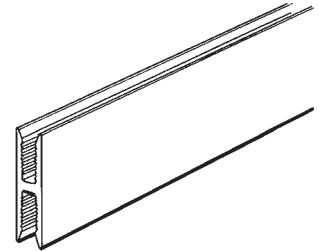
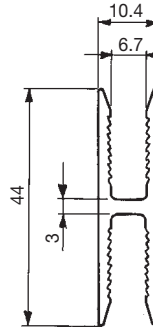

### Fencing Guide Rails

Designation	JSM A3130B
Ordering information	2TLJ040037R2600 (cut to size)
Material	Naturally anodized aluminum
Standard length	4.0 m (max)
Weight	0.530 kg/m
Holes	c-c = 275 mm, $\phi$ = 6 mm

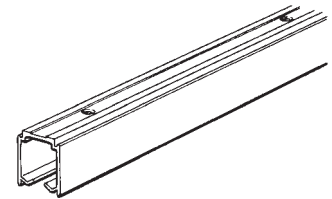
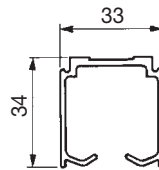

Designation	JSM A56
Ordering information	2TLJ040037R0800 (length 2.0 m, incl. screws) 2TLJ040037R4800 (length 6.0 m, incl. screws)
Material	Naturally anodized aluminum
Dimensions	44x25 mm
Standard length	2.0 m
Weight	1.585 kg/m
Holes	c-c = 500 mm $\phi$ = 5 mm
Delivered with	Screw JSM S8E Nut JSM M8B

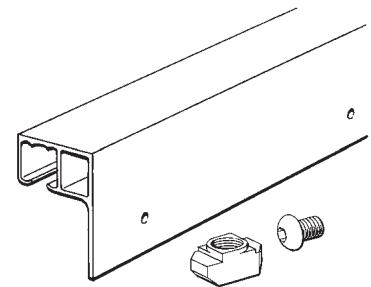
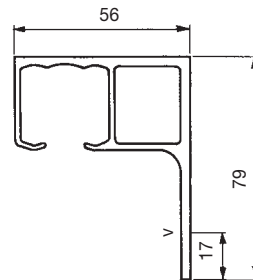



## Cable Ducting

Designation	JSM A25A
Ordering information	2TLJ040037R1300
Material	Naturally anodized aluminum
Dimensions	44x25 mm
Standard length	2.0 m
Weight	0.545 kg/m JSMA25A
Holes	c-c = 500 mm, $\phi = 5$ mm
Order unit	10 pcs / box

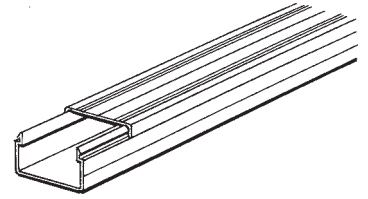
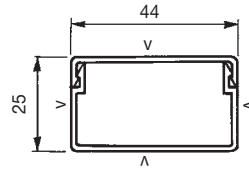

Designation	JSM A60A
Ordering information	2TLJ040037R1500
Material	Naturally anodized aluminum
Dimensions	44x60 mm
Standard length	2.0 m
Weight	0.923 kg/m JSMA60A
Holes	c-c = 500 mm, $\phi = 5$ mm
Order unit	10 pcs / box

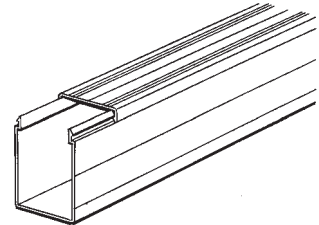
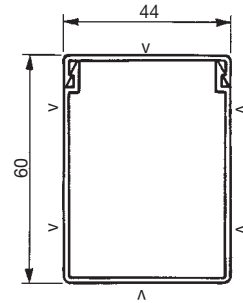

Designation	JSM A88
Ordering information	2TLJ040037R3300
Material	Naturally anodized aluminum
Dimensions	88x68 mm
Standard length	2.0 m
Weight	1.844 kg/m

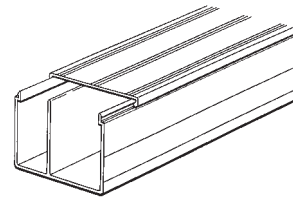
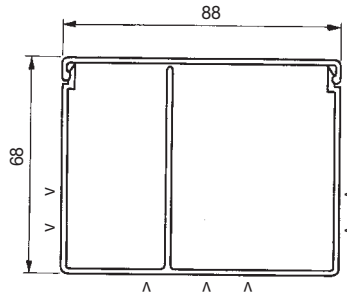

## Cable Tie

Designation	JSM X1
Ordering information	2TLJ040033R4300
Material	Nylon 6/6 black
Preassembled with	screws and nuts
Order unit	10 pcs / box



## Profiles for Installation of Acoustic Damping

### Profile for 25 mm Sound-Absorbing Panel, JSM YLA25A

Designation	JSM AS1
Ordering information	2TLJ040037R0900 (L = 2000)
Material	Naturally anodized aluminum
Dimensions	29x43 mm
Weight	0.545 kg/m

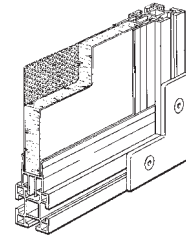
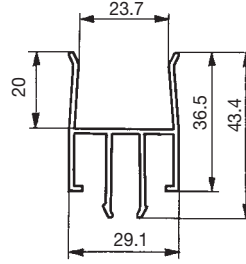

### Profile for 50 mm Sound-Absorbing Panel, JSM YLA50A

Designation	AS3
Ordering information	2TLJ042021R8100 (L = 6000)
Material	Naturally anodized aluminum
Dimensions	43x56 mm
Weight	0.694 kg/m

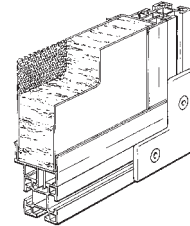
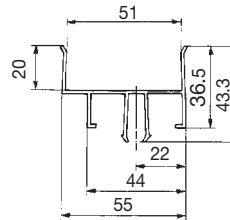

### Profile for Double 5mm Polycarbonate Panel, JSM YPC5

Designation	JSM AS2
Ordering information	2TLJ040037R1000 (L=2000)
Material	Naturally anodized aluminum
Dimensions	40x23 mm
Weight	0.510 kg/m

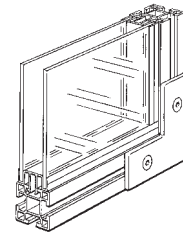
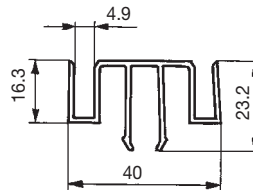

## Fittings

ABB Jokab Safety's fencing system is put together with various types of fittings. Uprights are anchored to the floor with floor angle fittings. With a small angle fitting it is possible to hang an electrical enclosure and strengthen the corners of free-standing walls. Corners and joints are constructed with the aid of T, L and I fittings. If angles different than 90° between the fence

sections are required, a JSM 35-K angle fitting can be used. This hinge has a distance between centres of 47 mm, which means that the gap between uprights will always be less than 20 mm. According to EN ISO 13857, the minimum permitted protection distance is 120 mm for a gap narrower than 20 mm.

### Floor/Angle Fitting

Designation	JSM 39-K
Ordering information	2TLJ040030R1400
Material	Aluminium
Preassembled with	Screw JSM S8C (x 2) Washer 9 x 18 x 1.5 (x 2) Nuts JSM M8B (x 2)
Quantity	10 pcs / box

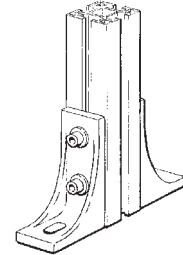
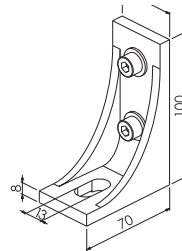

Designation	JSM 30B-K
Ordering information	2TLJ040030R0600
Material	Aluminium
Preassembled with	Screw JSM S8C (x 2) Washer 9 x 18 x 1.5 (x 2) Nuts JSM M8B (x 2)
Order unit	10 pcs / box

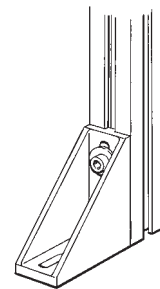
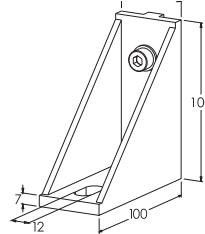

Designation	JSM 30B-K1
Ordering information	2TLA840030R1100
Material	Aluminium
Preassembled with	Screw JSM S8C (x 4) Washer 9 x 18 x 1.5 (x 4) Nuts JSM M8B (x 4) Washers JSM B8B (x 2)
Quantity	10 pcs / box

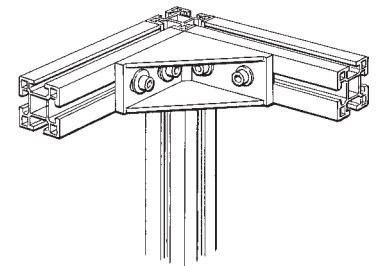
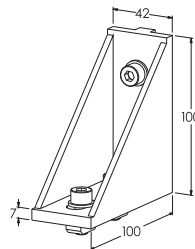

Designation	JSM 36-K1
Ordering information	2TLJ040030R0900
Preassembled with	Screws JSM S8D (x 3) Nuts JSM M8B (x 3)
Designation	JSM 36-K2
Ordering information	2TLJ040030R1000
Material	Aluminium
Preassembled with	Screws JSM S8D (x 3) Nuts JSM M8B (x 3)
Material	Zinc-plated steel
Quantity	10 pcs / box

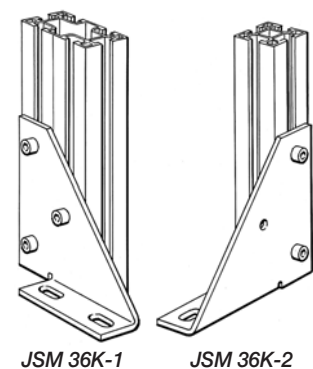
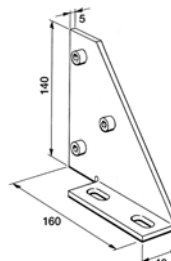

JSM 36K-1

JSM 36K-2

## Fittings - continued

### Small Angle Fitting (e.g. Electrical Cabinet Fitting)

Designation	JSM 31B-K Two counter sunk holes JSM31A1-K One counter sunk hole
Ordering information	2TLJ040030R1300 (JSM 31B-K) 2TLJ040030R0400 (JSM 31A1-K)
Material	Aluminum
Preassembled with	Screw JSM S8C Nut JSM M8B
Order unit	10 pcs/box

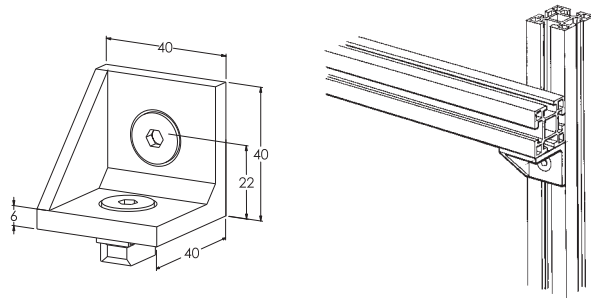

### L-Bracket

Designation	JSM 32B-K
Ordering information	2TLJ040030R0700
Material	Aluminum
Preassembled with	Screw JSM S8A Nut JSM M8B
Order unit	10 pcs/box

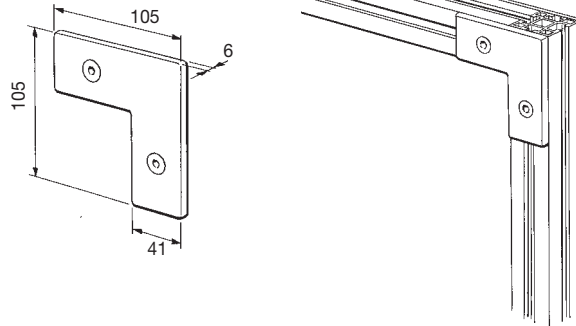

### T-Bracket

Designation	JSM 33B-K
Ordering information	2TLJ040030R0800
Material	Aluminum
Preassembled with	Screw JSM S8A Nut JSM M8B
Order unit	10 pcs/box

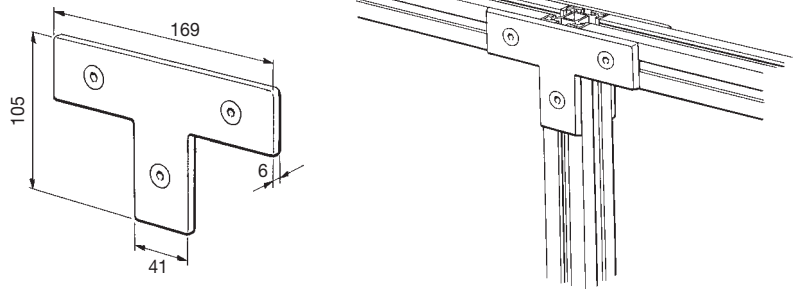

### I-Bracket, Joint

Designation	JSM 34B-K
Ordering information	2TLJ040030R1500
Material	Aluminum
Preassembled with	Screw JSM S8A Nut JSM M8B
Order unit	10 pcs/box

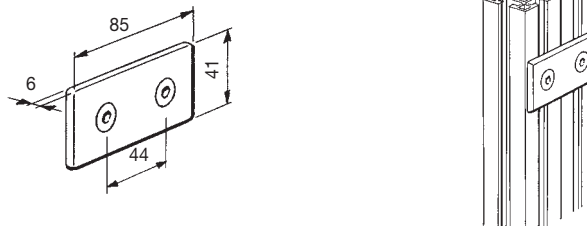

### Distance Screw

Designation	JSM 37
Ordering information	2TLJ040033R3100
Material	Zinc-plated steel
Order unit	10 pcs/box



## Angle Bracket

Designation	JSM D1C Hinge
Ordering information	2TLA040033R4800
Material	Polyamide, glass fiber reinforced
Preassembled with	JSM M8B JSM B8C JSM S8A
Color	Black
Order unit	2 pcs/bag, 10 pcs/box

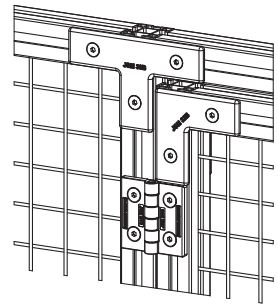
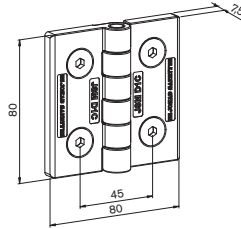

Designation	JSM 35-K
Ordering information	2TLJ040033R1400
Material	Zinc-plated steel
Preassembled with	Screw JSM S6A Nut JSM M6B
Hole	c-c = 47 mm
Order unit	2 pcs/box
<i>Note: The JSM 35-K must only be used for making fence angles.</i>	

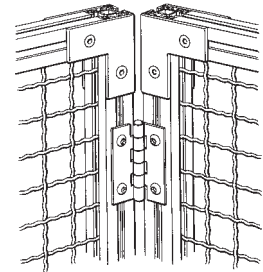
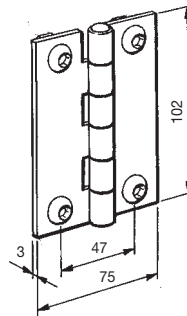

## Door Components

To mount conventional doors a hinge is available which permits an opening angle of 180°. For mounting a sliding door, guide rails and suspension wheels are utilised. Other sliding elements make it possible to

build different types of hatches. Guide rollers, for wide and heavy doors, door closers, fittings for sensors/switches etc are also available.

### Conventional Door

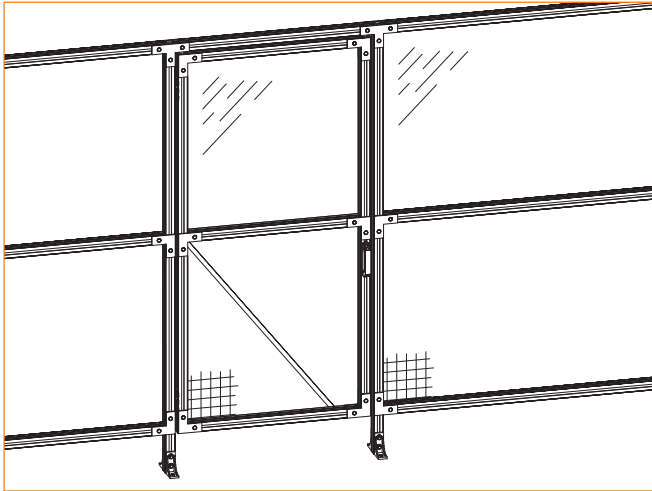

### Sliding Door

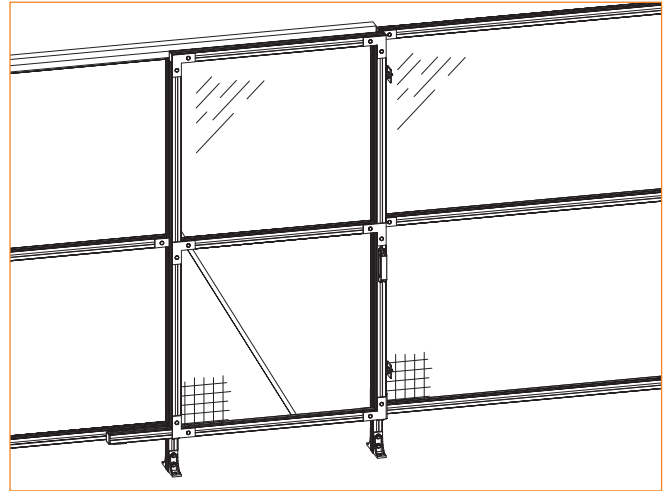

### Hatch

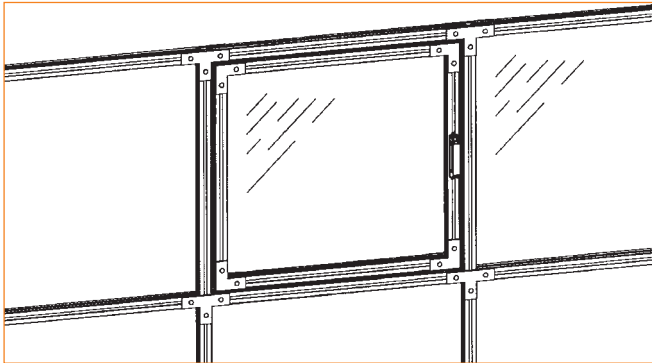

### Double Hatch

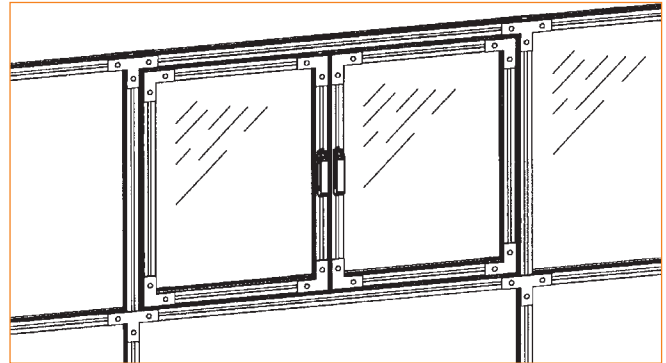

### Folding Hatch

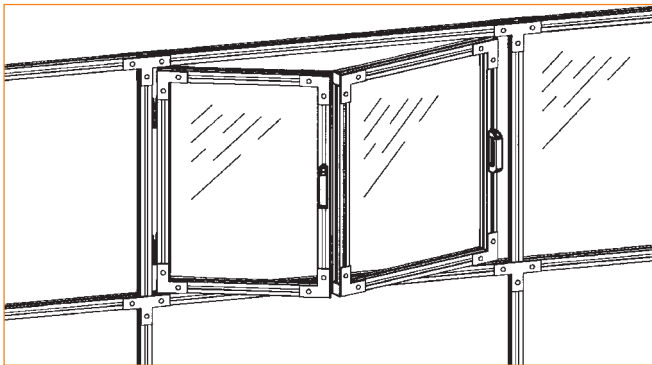

### Sliding Hatch

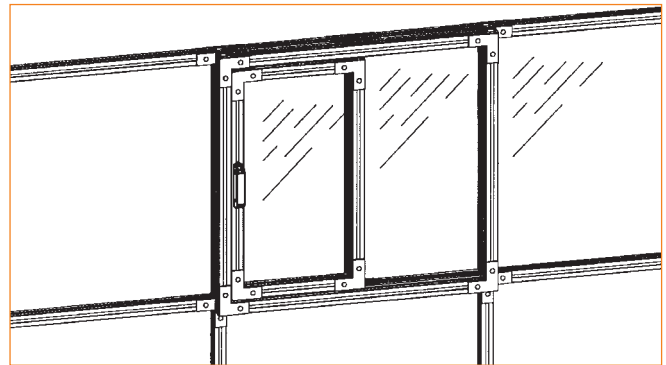

## Door Components

### Hinge Kit

Designation	JSM D1C Hinge
Ordering information	2TLA040033R4800
Material	Polyamide, glass fiber reinforced
Preassembled with	JSM M8B JSM B8C JSM S8A
Color	Black
Order unit	2 pcs/bag, 10 pcs/box

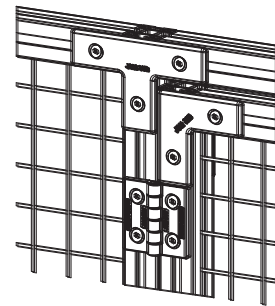
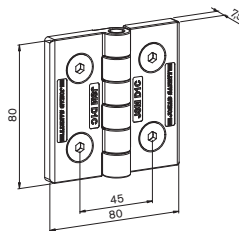

Designation	JSM D1A Hinge
Ordering information	2TLJ040033R1500
Material	Zinc-plated steel
Preassembled with	Screw JSM S6A Nut JSM M6B
Fixing holes	c-c = 62 mm
Order unit	2 pcs/box
<i>Note: JSM D1A must not be used as a fencing angle fitting because its gap can exceed 20 mm</i>	

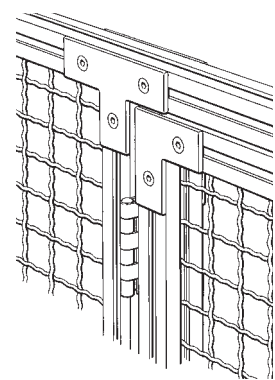
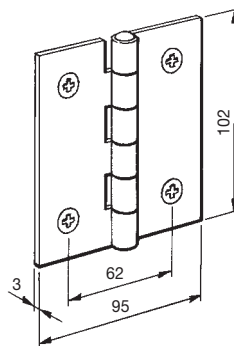

Designation	JSM D1B Spring Hinge
Ordering information	2TLJ042020R4700
Material	Zinc-plated steel
Preassembled with	Spacer plate, screws and nuts
<i>Note: The door gap will be 28 mm when installed.</i>	

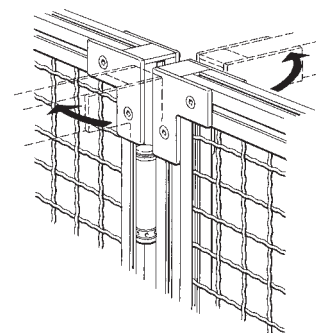
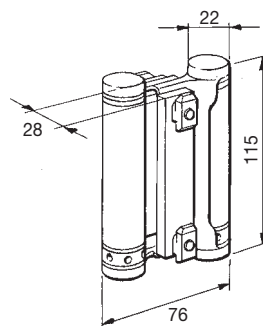

### Handle

Designation	JSM D2 Handle
Ordering information	2TLJ040033R0100
Material	Thermoplastic, black
Preassembled with	Screw JSM S8D Nut JSM M8B

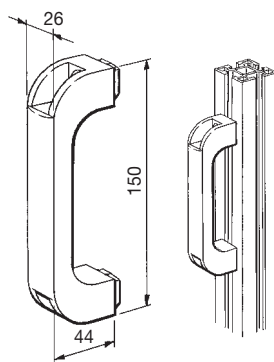

JSM D2

Designation	JSM D18 Handle
Ordering information	2TLJ042020R5000
Material	Handle: Thermoplastic, black Fittings: Aluminum
Preassembled with	Screws and nuts
Suitable for sliding door on the inside of the fence	

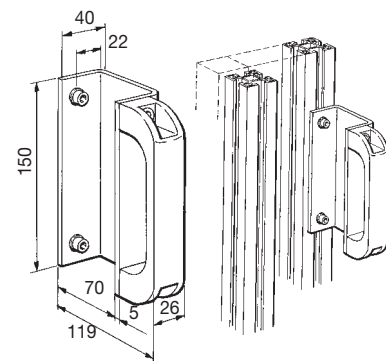

JSM D18

## Door Components - continued

### Door Closer

Designation	JSM D3 (Conventional Door)
Ordering information	2TLJ040033R0200
Material	Steel
Door closer Bracket	Aluminum
Preassembled with	Screws and nuts
Designation	JSM D19 (sliding door)
Ordering information	2TLA042020R5600
Material	Zinc-plated steel
Preassembled with	Screws and nuts

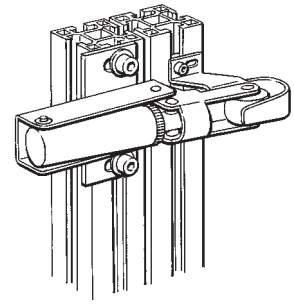
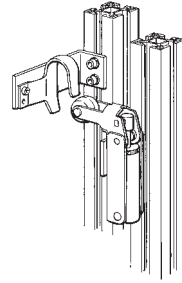
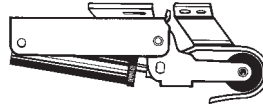

### Gas Spring

Designation	Gas Spring including Mount
Ordering information	2TLJ042024R1000
Material	Steel
Stroke length	300 mm
Preassembled with	Screws and nuts
Designation	JSM D22A Gas spring including mount
Ordering information	2TLA042024R1100
Material	steel
Stroke length	350 mm
Preassembled with	Screws and nuts
Fixing details included	
Side fastener	2TLJ042021R2700
U fitting	2TLJ042021R2800
Specify the required force when ordering	

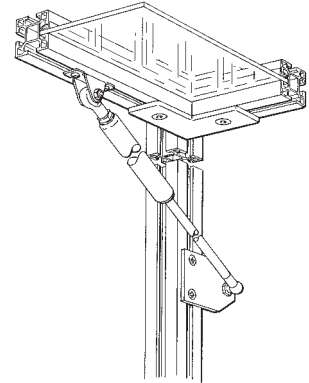
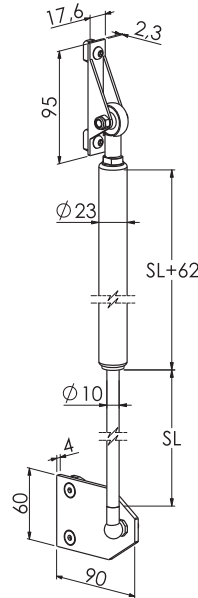

### Securing Plate for Padlock

Designation	JSM D17 Bracket for Padlock Hasp
Ordering information	2TLJ042020R2200
Material	Zinc-plated steel
<i>Note: Two pieces are required for one complete unit</i>	

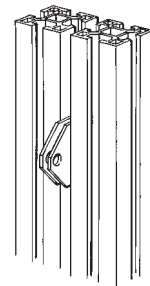
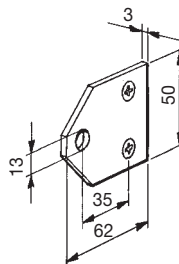



## Ball Catch

<b>Designation</b>	JSM D11B (Conventional Door)
<b>Ordering information</b>	2TLJ040033R4100
<b>Material</b>	
Brackets	Aluminium
Ball catch	Nickel-plated brass
<b>Preassembled with</b>	Screws and nuts

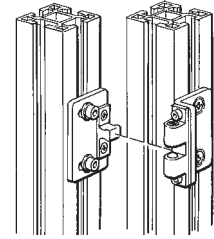
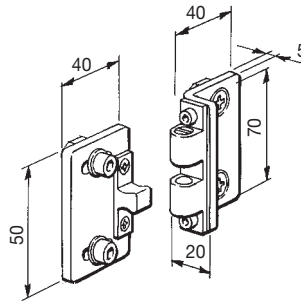

<b>Designation</b>	JSM D11C (Sliding Door)
<b>Ordering information</b>	2TLJ040033R4200
<b>Material</b>	
Brackets	Aluminium
Ball catch	Nickel-plated brass
<b>Preassembled with</b>	Screws and nuts

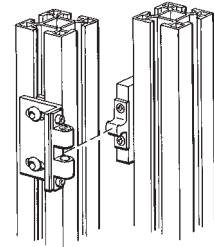
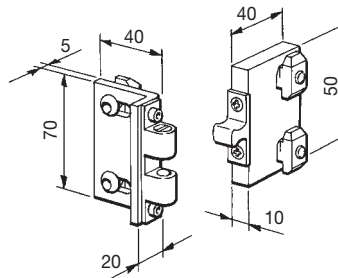

<b>Designation</b>	JSM D11D (Folding Door)
<b>Ordering information</b>	2TLJ042020R5200
<b>Material</b>	
Brackets	Aluminium
Ball catch	Nickel-plated brass
<b>Preassembled with</b>	Screws and nuts

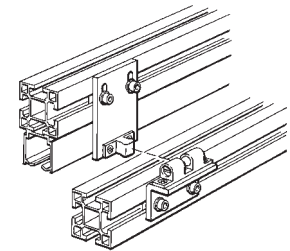
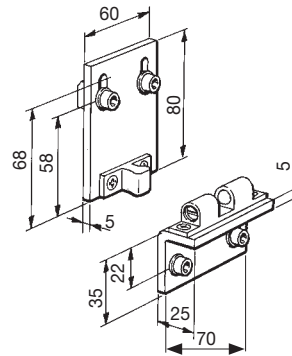

## Door Components - continued

### Upper Door Bolt

Designation	JSM D10A
Ordering information	2TLJ040033R2100
Material	
Brackets	Zinc-plated steel
Rod	Stainless steel
Preassembled with	Screws and nuts

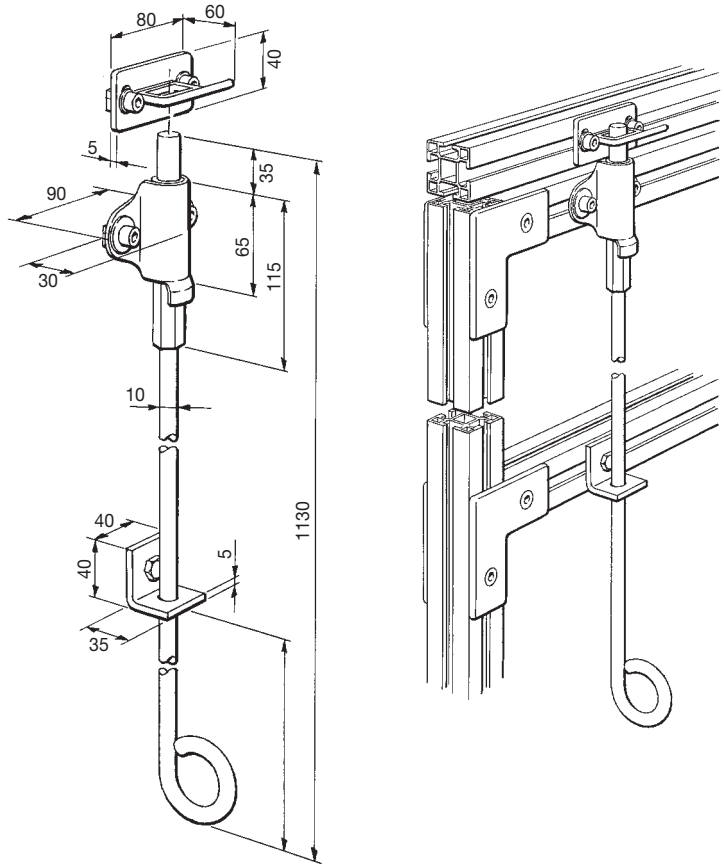

### Lower Door Bolt

Designation	JSM D10
Ordering information	2TLJ040033R2000
Material	
Brackets	Zinc-plated steel
Rod	Stainless steel
Preassembled with	Screws and nuts

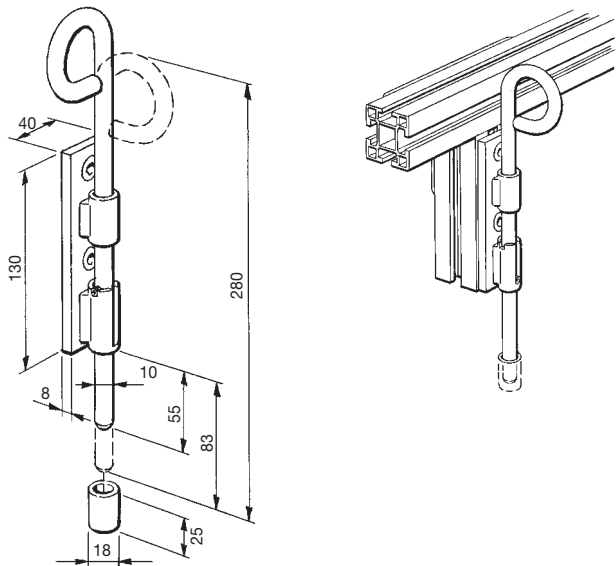

## Lower Door Bolt

Designation	JSM D10B
Ordering information	2TLJ040033R3800
Material	
Brackets	Zinc-plated steel
Rod	Stainless steel
Preassembled with	Screws and nuts

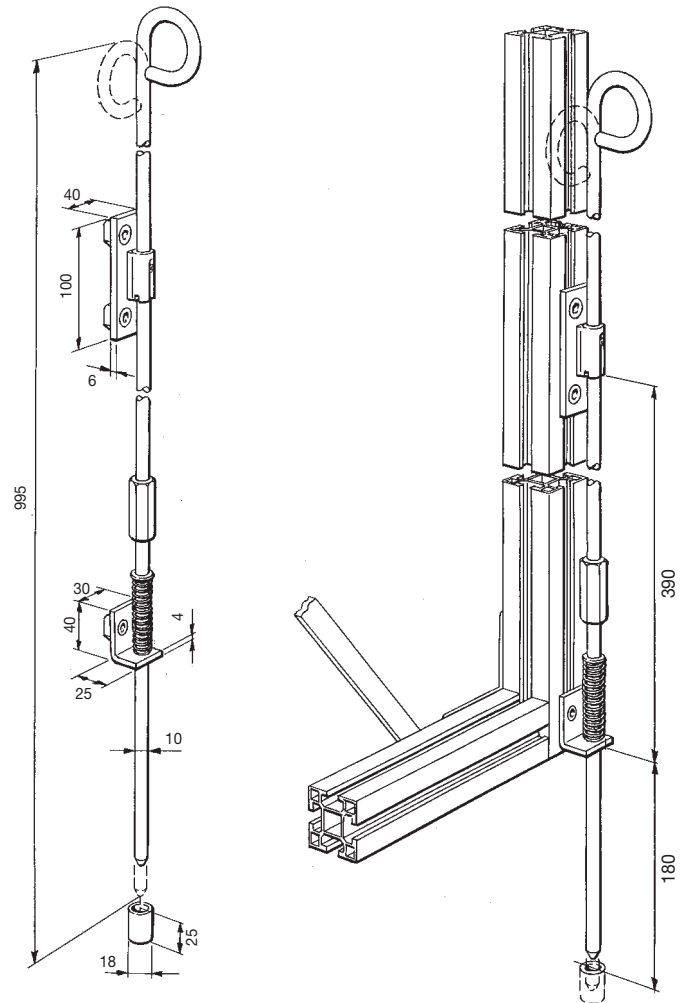

## Cam Lock

Designation	JSM D15
Ordering information	2TLJ040033R3900
Material	
Brackets	Aluminium
Lockunit	Polyamide black
Preassembled with	Screws and nuts
<i>Delivered without key</i>	
<b>Key to Cam Lock</b>	
Designation	JSM D16 for cam lock JSM D15
Ordering information	2TLJ040033R4400
Material	Zinc, black

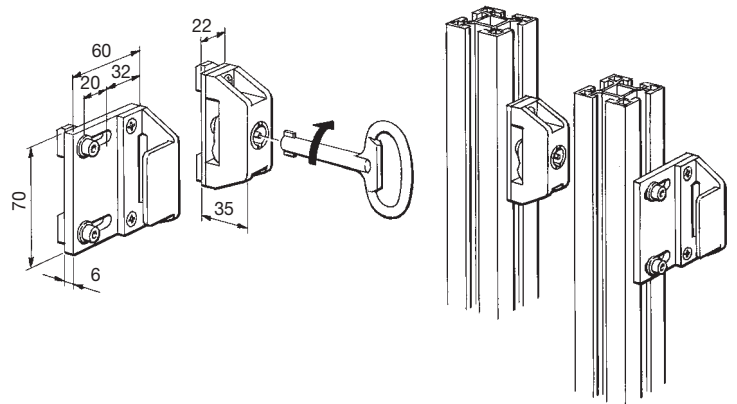

## Door Components - continued

### Sliding Bolt for Eden

Designation	JSM D20 (for Hinged Door)
Ordering information	2TLJ020302R1000
Material	Steel, painted yellow
Supplied without an Eden	
<i>For installation on hinged doors</i>	

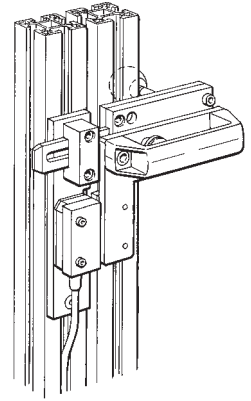
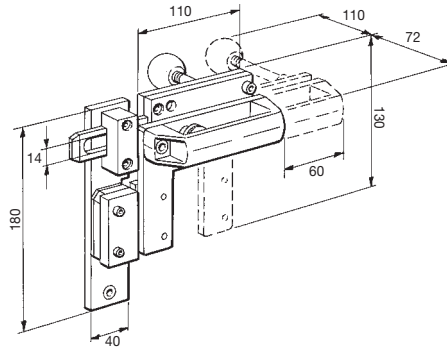

### Magne 1A Mount

Designation	JSM D21B
Ordering information	2TLJ042023R0500
Material	Anodized aluminium
Supplied without Magne 1A Magnetic lock	
<i>For installation on hinged doors</i>	

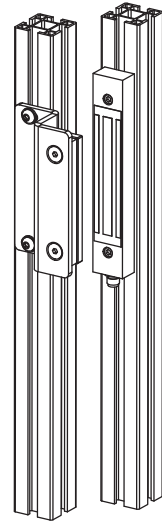
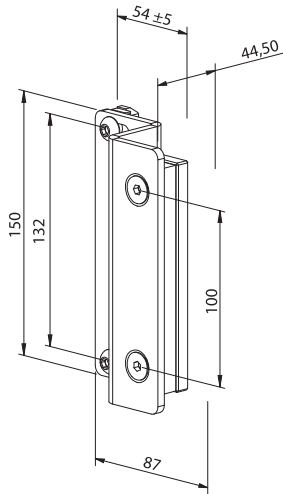

### Door Stop

Designation	JSM D13A
Ordering information	2TLJ040033R2600
Material	Natural anodized aluminium
Preassembled with	Screws and nuts

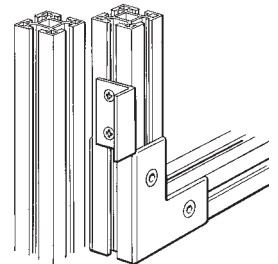
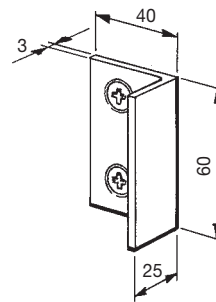

Designation	JSM D13
Ordering information	2TLJ040033R2500
Material	Zinc-plated steel
Preassembled with	Screws, nuts and vibration damper
<i>For mounting on vertical profiles</i>	

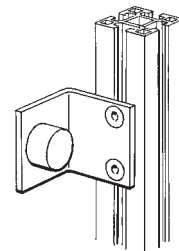
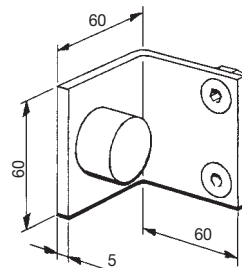

## Door Stop

Designation	JSM D13B
Ordering information	2TLJ040033R2700
Material	Zinc-plated steel
Preassembled with	Screws, nuts and vibration damper
<i>For mounting on horizontal profiles</i>	

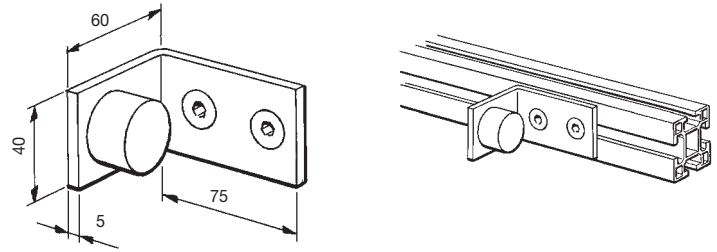

## Suspension Wheels

Designation	JSM D5
Ordering information	2TLJ040033R0400
<i>For aluminium profile guide rails JSM A3130B and JSM A56</i>	

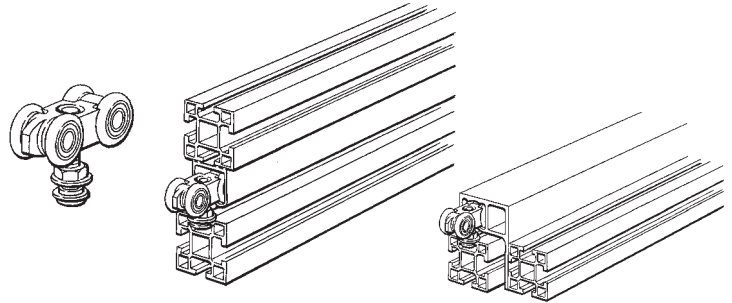

## Rectangular Sliding Element

Designation	JSM D6
Ordering information	2TLJ040033R0500
Material	Polyamid
Preassembled with	Screw and nut

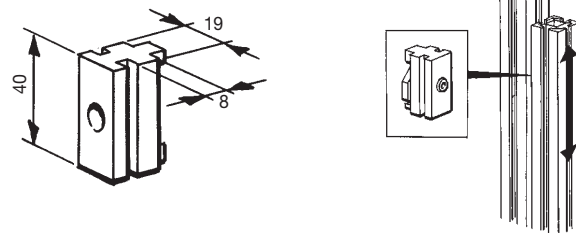

## Round Sliding Element

Designation	JSM D7
Ordering information	2TLJ040033R0600
Material	Polyamid
Preassembled with	Screw and nut

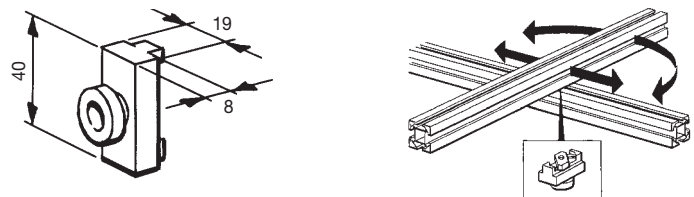

## Sliding Element Guide

Designation	JSM D8
Ordering information	2TLJ040033R0700
Material	Polyamid
Preassembled with	Screw and nut

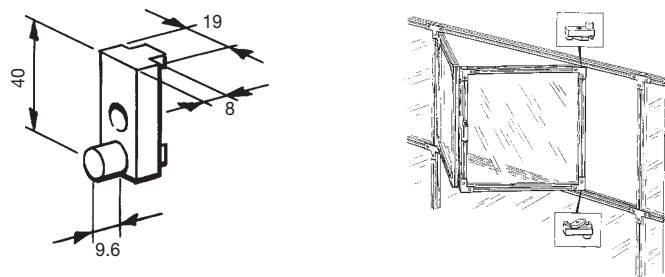

## Door Components - continued

### Guide Bracket for Sliding Door

Designation	JSM D12
Ordering information	2TLJ040033R2200
Material	Aluminium and PA6-6
Preassembled with	Screws and nuts
<i>For mounting on vertical profiles</i>	

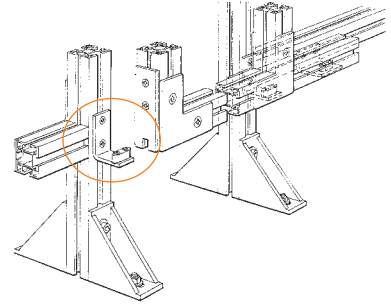
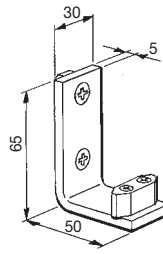

### Guide Bracket for Sliding Door

Designation	JSM D12A
Ordering information	2TLJ040033R2300
Material	Aluminium and PA6-6
Preassembled with	Screws and nuts
<i>For mounting on horizontal profiles</i>	

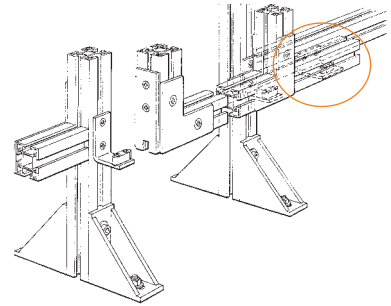
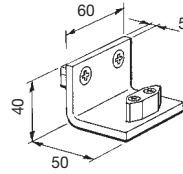

### Bracket for Guide Pin

Designation	JSM D12B
Ordering information	2TLJ040033R2400
Material	Aluminium
Preassembled with	Screws and nuts

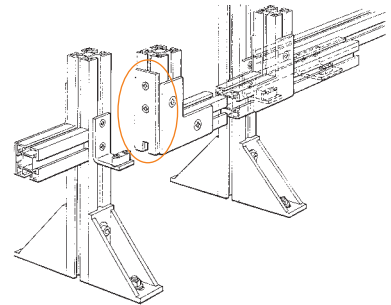
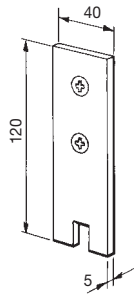

### Guide Roller for Conventional Door with Locking Mechanism

Designation	JSM D9-K
Ordering information	2TLJ040033R1100
Preassembled with	Angle bracket
Diameter	75 mm
Max. load	60 kg

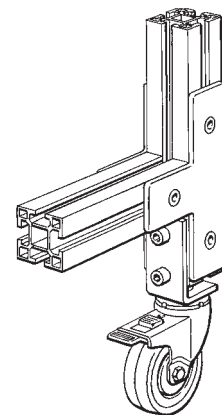
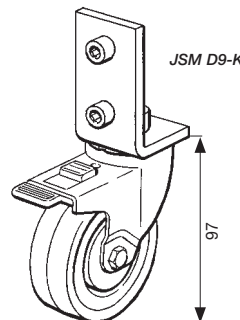

## Guide Roller for Sliding Door

Designation	JSM D9A-K
Ordering information	2TLJ040033R1300
Preassembled with	Angle bracket
Diameter	75 mm
Max. load	70 kg

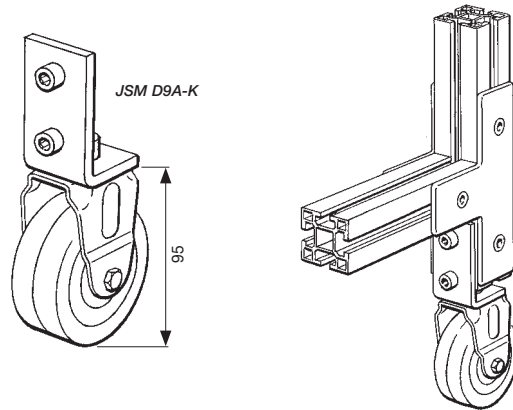

## Diagonal Bar for Door

Designation	JSM D14
Ordering information	2TLJ040033R2800
Material	Naturally anodized aluminium
Length	1160 mm
Preassembled with	Screws and nuts

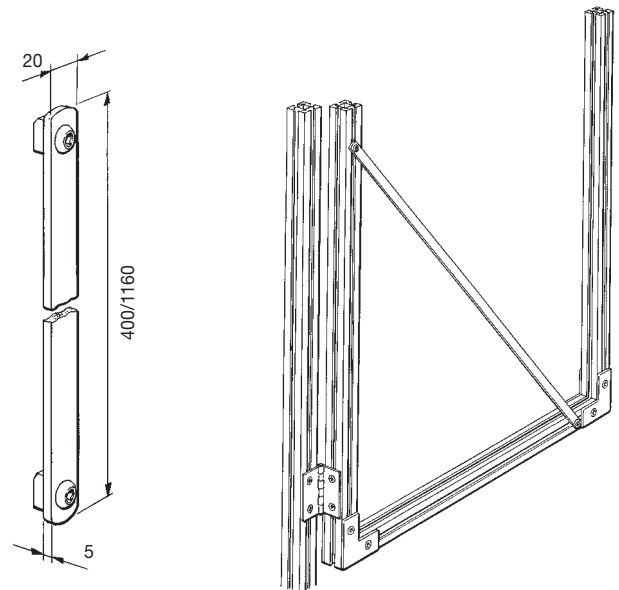

## Fittings for Switches

### Eden Fittings adapted for Sliding and Conventional Doors

Designation	JSM D4H
Ordering information	2TLJ040033R3600
Material	Aluminium
Preassembled with	Screws and nuts
<i>Note: Two fittings are needed for a complete Eden</i>	

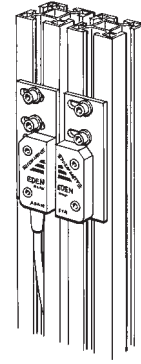
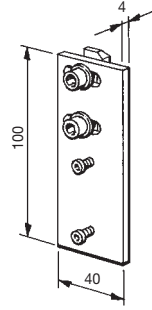

### Eden Fittings for Sliding Door (Flush with Fence)

Designation	JSM D4J
Ordering information	2TLJ042020R4000
Material	Aluminium
Preassembled with	Screws and nuts
<i>Note: One JSM D4H and one JSM D4J are needed for a complete unit</i>	

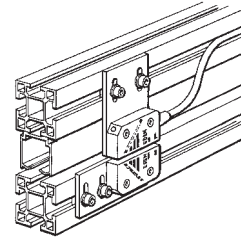
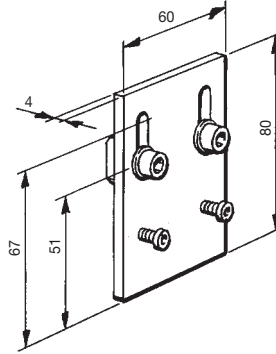

### JSNY5 Interlock Switch Fittings for Conventional Opening Door

Designation	JSM D4A
Ordering information	2TLJ040033R0900
Material	Zinc-plated steel
Preassembled with	Screws and nuts

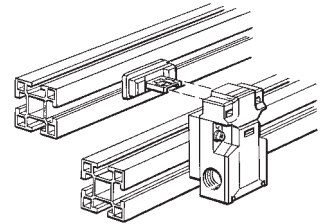
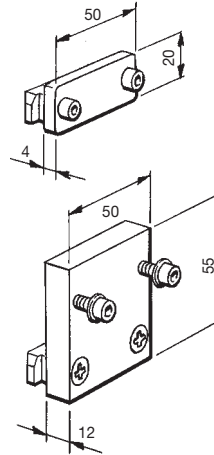

### JSNY5 Interlock Switch Fittings for Conventional Opening Door

Designation	JSM D4AA
Ordering information	2TLJ040033R3400
Material	Zinc-plated steel
Preassembled with	Screws and nuts

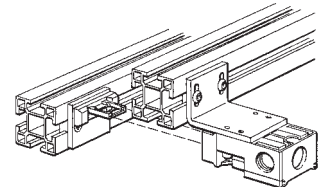
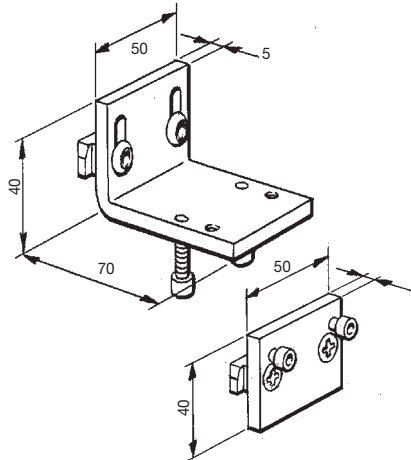



### JSNY5 Interlock Switch Fittings for Sliding Door

Designation	JSM D4B
Ordering information	2TLJ040033R1000
Material	Zinc-plated steel
Preassembled with	Screws and nuts

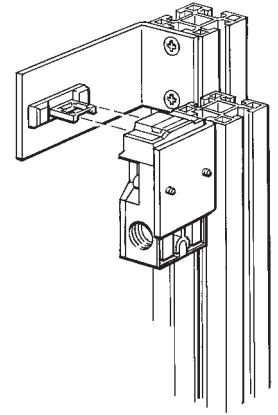
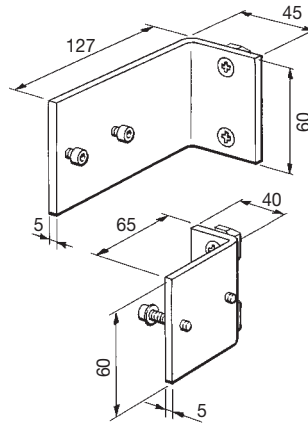

### JSNY7 Magnetic Switch Fittings for Hinged Door

Designation	JSM D4E
Ordering information	2TLJ040033R1800
Material	Aluminium
Preassembled with	Screws and nuts
<i>Note: Two fittings are needed for a complete JSNY7</i>	

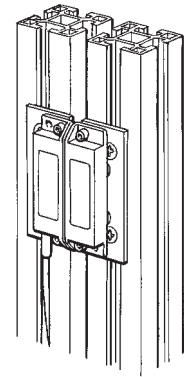
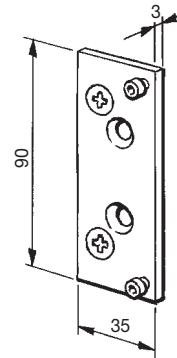

### JSNY7 Magnetic Switch Fittings for Sliding Door

Designation	JSM D4G
Ordering information	2TLJ040033R3300
Material	Aluminium
Preassembled with	Screws and nuts

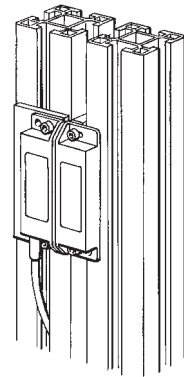
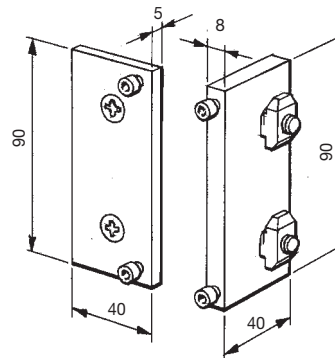

## Fittings for Switches - continued

### JSNY8/JSNY9 Interlock Switch Fittings for Sliding Door

Designation	JSM D4D
Ordering information	2TLJ040033R1700
Material	Zinc-plated steel
Preassembled with	Screws and nuts

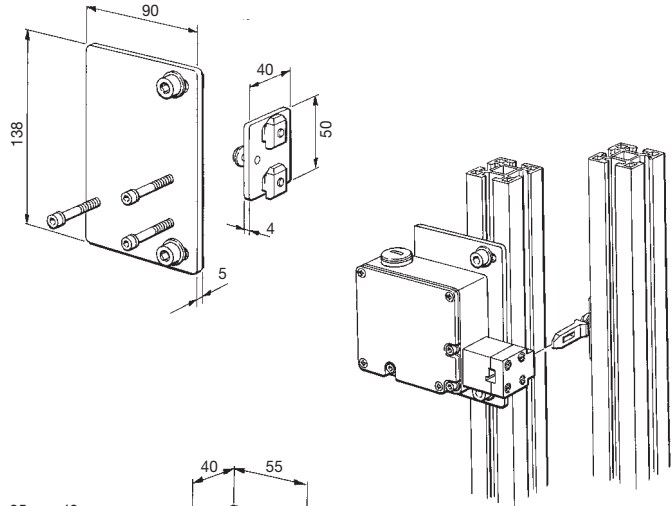

### JSNY8/JSNY9 Interlock Switch Fittings for Conventional Opening Door

Designation	JSM D4C
Ordering information	2TLJ040033R1600
Material	Zinc-plated steel
Preassembled with	Screws and nuts

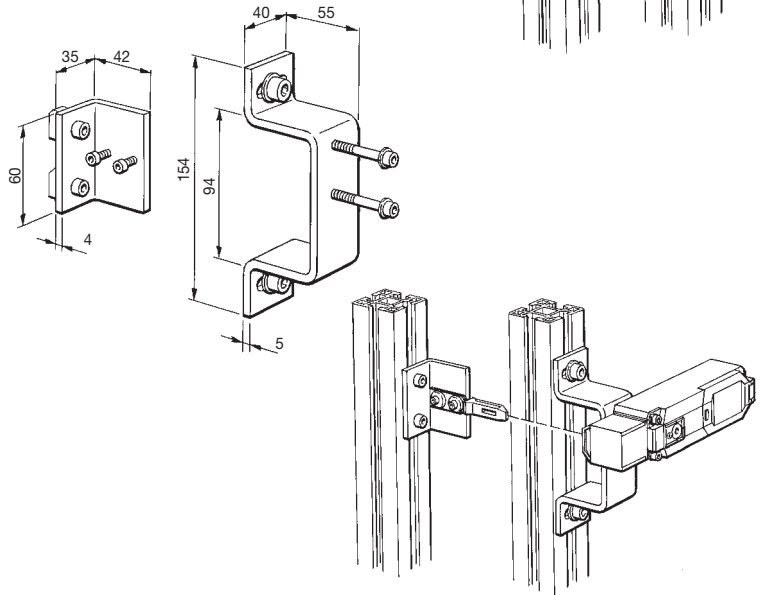

### JSNY9 Interlock Switch Fittings for Sliding Door

Designation	JSM D4F
Ordering information	2TLJ040033R3000
Material	Zinc-plated steel
Preassembled with	Screws and nuts

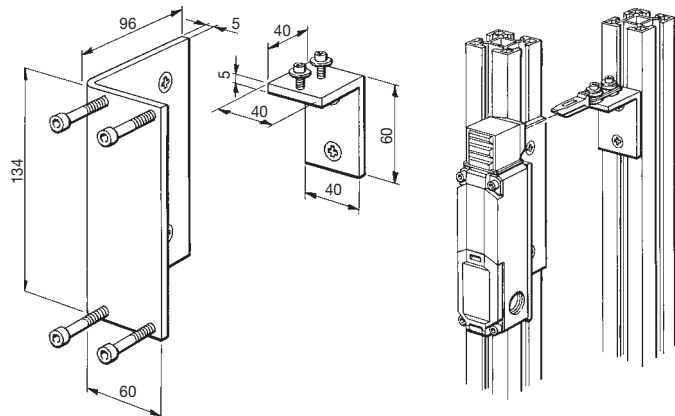

## Terminal Caps and Strips

Terminal caps are available to cover profile ends, thus eliminating sharp edges. Strips are also

available, both narrow and wide, to cover the side of the fencing profile.

### Terminal Cap for JSM A44A

Designation	JSM L1A (yellow) JSM L1B (grey)
Ordering information	2TLJ040034R0000 (JSM L1A) 2TLJ040034R0300 (JSM L1B)
Material	Polyamide
Dimensions	44x44 mm

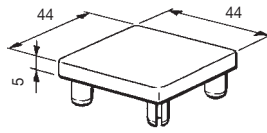

### Terminal Cap for JSM A4488A

Designation	JSM L4A (yellow (yellow)) JSM L4B (grey)
Ordering information	2TLJ040034R0400 (JSM L4A) 2TLJ040034R0500 (JSM L4B)
Material	Polyamide
Dimensions	44x4488 mm

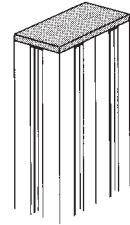
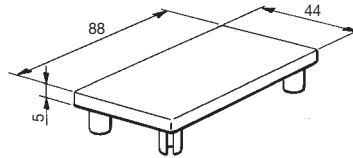

### Terminal Cap for JSM A25

Designation	JSM L2 (yellow)
Ordering information	2TLJ040034R0100
Material	Polyamide, grey
Dimensions	44x25 mm

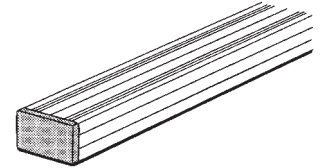
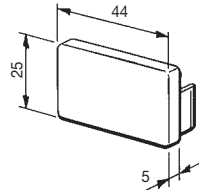

### Terminal Cap for JSM A44A60

Designation	JSM L3
Ordering information	2TLJ040034R0200
Material	Polyamide, grey
Dimensions	44x60 mm

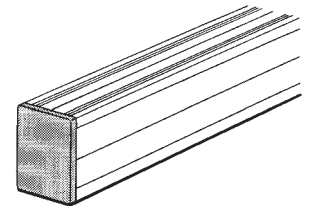
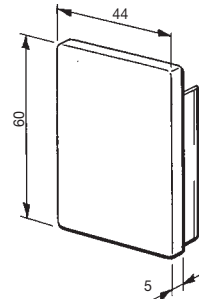

### Narrow Cover Strip, for JSM A44A, JSM A44A, JSM A4488A and JSM A8888



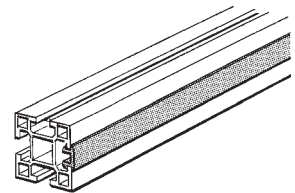
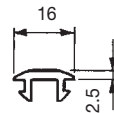





Designation	JSM T3 (yellow) JSMT3B (grey)
Ordering information	2TLJ040037R3100 (JSM T3A) 2TLJ040037R3200 (JSM T3B)
Material	ABS
Dimensions	16 mm
Order unit	2 m

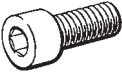
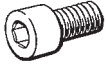

## Accessories

All fittings and door components are delivered complete with screws, washers and nuts pre-mounted.

For cable ducting, the screws (S5B) and nuts (M5B) have to be ordered separately (4 pcs/2m).

Designation		Ordering Information	Description	Dimension	Material	Order Unit
JSM S5B		2TLJ041039R0100	Screw to cable ducting	M5x12	Zinc Plated Steel	100 pcs/box
JSM S6A		2TLJ041039R0200	Screw for hinge cross-slotted Z (pozidrive)	M6x12	Zinc Plated Steel	100 pcs/box
JSM S8A		2TLJ041019R0000	Fixing screw countersunk.	M8x16	Zinc Plated, Dacrolit	100 pcs/box
JSM S8C		2TLJ041014R0200	Fixing screw for floor fitting and small angle	M8x20	Zinc Plated Steel	100 pcs/box
JSM S8D		2TLJ041014R0100	Fixing screw	M8x16	Zinc Plated Steel	100 pcs/box
JSM S8E		2TLJ041019R0100	Fixing screw for Guide rail JSM A56	M8x12	Zinc Plated Steel	100 pcs/box
JSM M4B		2TLJ040035R0700	Locking nut	M4	Zinc Plated Steel	100 pcs/box
JSM M5B		2TLJ040035R0400	Locking nut	M5	Zinc Plated Steel	100 pcs/box
JSM M6B		2TLJ040035R0500	Locking nut	M6	Zinc Plated Steel	100 pcs/box
JSM M8B		2TLJ040035R0600	Locking nut	M8	Zinc Plated Steel	100 pcs/box
JSM X1		2TLJ040033R4300	Cable tie	2.5-7.8 mm	Nylon black UV-resistant	10 pcs/box

## Surfaces

The choice of net and surfaces depends, among other things, on the protection distance. In the case of netting, a minimum distance of 200 mm (for anyone aged 14 or older) with a mesh size of 40x40 mm in accordance with EN ISO 13857.

For closer protection distances and for noise reduction, solid panels are used. Panels are available in different materials. For protection of welding cells, polycarbonate welding transparencies are used.

### Welded Net

Designation: JSM YN30W\_\_

Stitch: 30x30 mm

Thread: 3.5mm

Designation: JSM YN40W\_\_

Stitch: 40x40 mm

Thread: 3.5mm

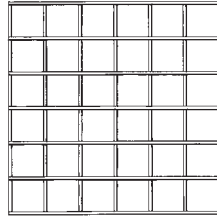

Ordering information	Designation	Stitch	Material	Dimensions	Type
2TLJ042150R1800	JSM YN30W1 welded black mesh	30x30 mm	Steel, black powder coated	2020 x 1123 mm	Welded
2TLA850103R3100	JSM YN30W2 welded black mesh	30x30 mm	Steel, black powder coated	1474 x 1927 mm	Welded
2TLJ040040R1300	JSM YN40W1 welded black mesh	40x40 mm	Steel, black powder coated	864 x 2020 mm	Welded
2TLJ040040R1400	JSM YN40W2 welded black mesh	40x40 mm	Steel, black powder coated	1074 x 1816 mm	Welded
2TLJ040040R1500	JSM YN40W3 welded black mesh	40x40 mm	Steel, black powder coated	1074 x 2016 mm	Welded
2TLJ040040R2000	JSM YN40W4 welded black mesh	40x40 mm	Steel, black powder coated	1474 x 2016 mm	Welded
2TLJ040040R2100	JSM YN40W5 welded black mesh	40x40 mm	Steel, black powder coated	1474 x 1816 mm	Welded
2TLJ042020R2500	JSM YN40W8 welded black mesh	40x40 mm	Steel, black powder coated	1123 x 2020 mm	Welded

### Net Locking for Welded Netting with Outer Wire

Designation	JSM NL2
Ordering information	2TLJ040031R0600
Material	PA/ABS
Quantity	100 pcs/box

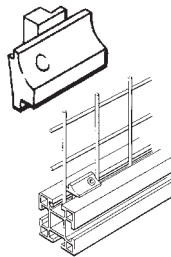

### Net Locking for Welded and Woven Wire Mesh Netting, with or without Outer Wires

Designation	JSM NL3
Ordering information	2TLJ040031R0800
Material	Zinc
Preassembled with	Screws
Quantity	100 pcs/box

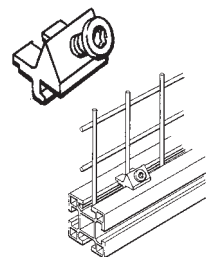

### Shockproof Plastic Paneling

Designation: JSM Y\_\_

Thickness: 5 mm

Other materials can be supplied on request.

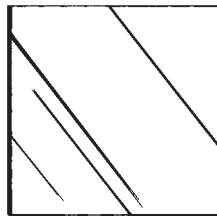

Ordering information	Designation	Material	Dimensions
2TLJ050003R0700	JSM YPC5A9	Clear polycarbonate	1219 x 2438 mm
2TLA850303R8000	JSM YPC5A8	Clear polycarbonate	1474 x 1520 mm
2TLJ040039R2500	JSM YPC3AC1	Polycarbonate, dark tint, weld protected	2050 x 3000 mm

## Surfaces - continued

### Steelplate Cross-Bent Sheet Metal Panel

Designation: JSM YGP1A9

Thickness: 1 mm

Other materials can be supplied on request.

Ordering information	Designation	Material	Dimensions
Call for quote	JSM YGP1A9	Galvanized sheet metal, x-cracked	Cut to size

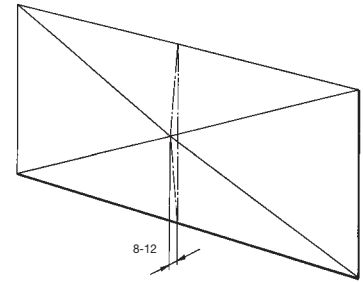

### Panel Fixings

Designation: JSM PL1\_\_

For 5mm panels.

Ordering information	Designation	Material	Length	Quantity
2TLJ040038R0100	JSM PL1A	PVC, black	842 mm	50 pcs/package
2TLJ040038R0200	JSM PL1B	PVC, black	1152 mm	50 pcs/package
2TLJ040038R0300	JSM PL1C	PVC, black	2000 mm	50 pcs/package
2TLJ040038R0400	JSM PL1D	PVC, black	732 mm	50 pcs/package

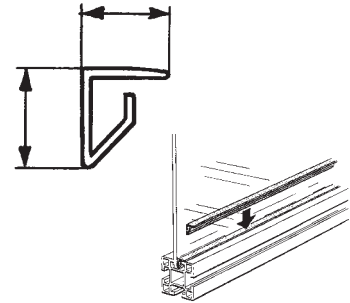

### Panel Lockings

Designation: JSM PL3

For 5mm panels.

Ordering information	Designation	Material	Preassembled with
2TLJ040038R1100	JSM PL3	Zinc	Screws

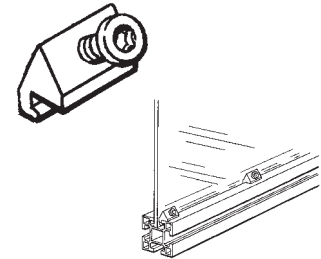

### Soundabsorbing Panels

Designation: JSM YLA25A\_\_

Thickness: 25 mm

Designation: JSM YLA50A\_\_

Thickness: 50 mm

Cut to size, maximum dimension 2000x1200.

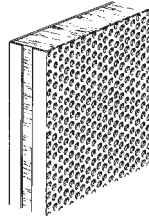

Ordering information	Designation	Material	Dimensions	Weight
Call for quote	JSM YLA25A9	Outside – painted sheet metal Inside – galvanized preformed sheet Metal core – steel wool	Cut to size	13.8 kg/m <sup>2</sup>
Call for quote	JSM YLA25A1	Outside – painted sheet metal Inside – galvanized preformed sheet Metal core – steel wool	Cut to size	13.8 kg/m <sup>2</sup>
Call for quote	JSM YLA50A9	Outside – painted sheet metal Inside – galvanized preformed sheet Metal core – steel wool	Cut to size	21.0 kg/m <sup>2</sup>

Note: Mounting profile JSM AS1 used for JSM YLA25A\_\_ and mounting profile JSM AS3 used for JSM YLA50A\_\_.

## Component List - Quick-Guard® Aluminum Profiles

Designation	Ordering Information	Description
JSM A4416	2TLJ040037R7400	Fencing profile, 44 x 16 mm natural anodized aluminum.
JSM A44A	2TLJ040037R3700	Fencing profile, 44 x 44 mm natural anodized aluminum. Standard length 2.0 m.
	2TLJ040037R4100	Fencing profile, 44 x 44 mm natural anodized aluminum. Standard length 6.0 m.
JSM A4488A	2TLJ040037R4300	Fencing profile, 44 x 88 mm natural anodized aluminum. Standard length 2.0 m.
	2TLJ040037R4500	Fencing profile, 44 x 88 mm natural anodized aluminum. Standard length 6.0 m.
JSM A8888	2TLJ040037R7900	Fencing profile, 88 x 88 mm natural anodized aluminum.
JSM A12	2TLJ040037R2700	U-profile, 23 x 10.4 mm natural anodized aluminum. Standard length 1.076 m.
	2TLJ040037R4600	U-profile, 23 x 10.4 mm natural anodized aluminum. Standard length 1.476 m.
	2TLJ040037R4700	U-profile, 23 x 10.4 mm natural anodized aluminum. Standard length 2.0 m.
JSM A13	2TLJ040037R5300	H-profile, 23 x 10.4 mm natural anodized aluminum. Standard length 2.0 m.
JSM A3130B	2TLJ040037R2600	Guide rail, 34 x 33 mm natural anodized aluminum. Standard length 4.0 m. Predrilled holes, c-c = 275 mm, Ø = 6 mm.
JSM A56	2TLJ040037R0800	Guide rail, 79 x 56 mm natural anodized aluminum. Standard length 6.0 m. Predrilled holes, c-c = 450 mm, Ø = 8.5 mm. Delivered with JSM S8C screw and JSM M8B nut.
JSM 25A	2TLJ040037R1300	Cable ducting, 44 x 25 mm natural anodized aluminum. Standard length 2.0 m. Predrilled holes, c-c = 500 mm, Ø = 5 mm.
JSM A60A	2TLJ040037R1500	Cable ducting, 44 x 60 mm natural anodized aluminum. Standard length 2.0 m. Predrilled holes, c-c = 500 mm, Ø = 5 mm.
JSM A88	2TLJ040037R3300	Cable ducting, 88 x 68 mm natural anodized aluminum. Standard length 2.0 m. Without predrilled holes.
JSM X1	2TLJ040033R4300	Cable tie, preassembled with screw and nut.
JSM AS1	2TLJ040037R0900	Fencing profile for Mounting of 25 mm Sound Absorbing Panels JSM YLA25A9, 43 x 29 mm natural anodized aluminum. Standard length 2.0 m.
JSM AS3	2TLJ040037R8100	Fencing profile for Mounting of 50 mm Sound Absorbing Panels JSM YLA50A, 43 x 56 mm natural anodized aluminum. Standard length 2.0 m.
JSM AS2	2TLJ040037R1000	Fencing profile for Mounting of Double 5 mm Sound Absorbing Panels JSM YPC5_ , 40 x 23 mm natural anodized aluminum. Standard length 2.0 m.

*Note: All fencing profiles can be ordered in meters. Ask your ABB Jokab Safety representative for more information.*

*Send requests for quotations to [rfq@jokabsafetyna.com](mailto:rfq@jokabsafetyna.com)*

## Component List - Quick-Guard® Fittings

Designation	Ordering Information	Description
JSM 39-K	2TLJ040030R1400	Floor/angle fitting, aluminum. Preassembled with JSM S8C (x 2) screws, 9 x 18 x 1.5 (x 2) washers and JSM M8B (x 2) nuts.
JSM 30B-K	2TLJ040030R0600	Floor/angle fitting, aluminum. Preassembled with JSM S8C (x 2) screws, 9 x 18 x 1.5 (x 2) washers and JSM M8B (x 2) nuts.
JSM 30B-K1	2TLA840030R1100	Floor/angle fitting, aluminum. Preassembled with JSM S8C (x 4) screws, 9 x 18 x 1.5 (x 4) washers, JSM M8B (x 4) nuts and JSM B8B (x 4) washers.
JSM 36-K1	2TLJ040030R0900	Floor/angle fitting, zinc-plated steel with outer flange. Preassembled with JSM S8C (x 3) screws, 9 x 18 x 1.5 (x 3) washers and JSM M8B (x 2) nuts.
JSM 36-K2	2TLJ040030R1000	Floor/angle fitting, zinc-plated steel with inner flange. Preassembled with JSM S8D (x 2) screws and JSM M8B (x 2) nuts.
JSM 31B-K	2TLJ040030R1300	Small angle fitting, aluminum with 2 counter-sunk holes. Preassembled with JSM S8C screw and JSM M8B nut.
JSM 31A1-K	2TLJ040030R0400	Small angle fitting, aluminum with 1 counter-sunk hole. Preassembled with JSM S8C screw and JSM M8B nut.
JSM 32B-K	2TLJ040030R0700	L-fitting, aluminum. Preassembled with JSM S8A screw and JSM M8B nut.
JSM 33B-K	2TLJ040030R0800	T-fitting, aluminum. Preassembled with JSM S8A screw and JSM M8B nut.
JSM 34B-K	2TLJ040030R1500	I-fitting, joint, aluminum. Preassembled with JSM S8A screw and JSM M8B nut.
JSM 37	2TLJ040033R3100	Distance screw, galvanized steel.
JSM 35-K	2TLJ040033R1400	Angle bracket, galvanized steel. Preassembled with JSM S6A screw and JSM M6B nut.

## Component List - Quick-Guard® Door Components

Designation	Ordering Information	Description
JSM D1A	2TLJ040033R1500	Hinge kit, galvanized steel. Preassembled with JSM S6A screw and JSM M6B nut.
JSM D1B	2TLJ040020R4700	Spring hinge kit, black thermoplastic. Preassembled with screws, nuts and spacer plate.
JSM D1YR	2TLA850003R0100	Lift-off right hinge kit, galvanized steel.
JSM D1YL	2TLA850003R0000	Lift-off left hinge kit, galvanized steel.
JSM D2	2TLJ040033R0100	Handle, black thermoplastic. Preassembled with JSM S8D screw and JSM M8B nut.
JSM D17	2TLJ042020R2200	Padlock bracket, galvanized steel. 2 pieces required for one complete unit.
JSM D3	2TLJ040033R0200	Door closer for conventional door with damper and mounting components.
JSM D19	2TLJ042020R5600	Door closer for sliding door with damper and mounting components. Preassembled with screws and nuts.

*Send requests for quotations to [rfq@jokabsafetyna.com](mailto:rfq@jokabsafetyna.com)*



## Component List - Quick-Guard® Door Components

Designation	Ordering Information	Description
JSM D11B	2TLJ040033R4100	Ball catch for conventional door, aluminum and brass. Preassembled with with screws and nuts.
JSM D11C	2TLJ040033R4200	Ball catch for sliding door, aluminum and brass. Preassembled with with screws and nuts.
JSNA-AH-7600-12	2TLA850203R2400	12" heavy duty slide feature full extension, a load rating of up to 500 lbs per slide, and utilize a slide silencing feature.
JSNA-AH-7600-18	2TLA850303R8600	18" heavy duty slide feature full extension, a load rating of up to 500 lbs per slide, and utilize a slide silencing feature.
JSNA-AH-7600-30	2TLA850003R1000	30" heavy duty slide feature full extension, a load rating of up to 500 lbs per slide, and utilize a slide silencing feature.
JSNA-AH-7600-32	2TLA850203R2700	32" heavy duty slide feature full extension, a load rating of up to 500 lbs per slide, and utilize a slide silencing feature.
JSNA-AH-7600-34	2TLA850003R9200	34" heavy duty slide feature full extension, a load rating of up to 500 lbs per slide, and utilize a slide silencing feature.
JSNA-AH-7600-36	2TLA850003R2000	36" heavy duty slide feature full extension, a load rating of up to 500 lbs per slide, and utilize a slide silencing feature.
JSNA-AH-7600-40	2TLA850003R2100	40" heavy duty slide feature full extension, a load rating of up to 500 lbs per slide, and utilize a slide silencing feature.
JSNA-AH-7600-42	2TLA850003R9500	42" heavy duty slide feature full extension, a load rating of up to 500 lbs per slide, and utilize a slide silencing feature.
JSNA-AH-7600-44	2TLA850203R2800	44" heavy duty slide feature full extension, a load rating of up to 500 lbs per slide, and utilize a slide silencing feature.
JSNA-AH-7600-48	2TLA850003R8000	48" heavy duty slide feature full extension, a load rating of up to 500 lbs per slide, and utilize a slide silencing feature.
JSNA-AH-7600-54	2TLA850003R8600	54" heavy duty slide feature full extension, a load rating of up to 500 lbs per slide, and utilize a slide silencing feature.
JSNA-AH-7600-60	2TLA850103R0100	60" heavy duty slide feature full extension, a load rating of up to 500 lbs per slide, and utilize a slide silencing feature.
JSM D10A	2TLJ040033R2100	Locking bolt for upper door, zinc-plated steel brackets and stainless steel rod. Preassembled with screws and nuts.
JSM D10	2TLJ040033R2000	Locking bolt for lower door, zinc-plated steel brackets and stainless steel rod. Preassembled with screws and nuts.
JSM D10B	2TLJ040033R3800	Locking bolt for lower door, zinc-plated steel brackets and stainless steel rod. Preassembled with screws and nuts.
JSM D15	2TLJ040033R3900	Cam lock with aluminum brackets and black polyamide lock unit. Preassembled with screws and nuts. Delivered without key.
JSM D16	2TLJ040033R4400	Key to cam lock, black zinc.
JSM D20	2TLJ020302R1000	Sliding unit for Eden for conventional door, yellow steel.

*Send requests for quotations to [rfq@jokabsafety.com](mailto:rfq@jokabsafety.com)*

## Component List - Quick-Guard® Door Components continued

Designation	Ordering Information	Description
JSNA-SafeSlide™	2TLA850003R0800	Eden lockout assembly for safe lockout at the door, yellow and black steel with UHMW slide block. Provisions for up to 6 locks that fastens the metal plate between the Eden pair. Adjustable for either right side or left side opening doors. Preassembled with JSM S8E screw and JSM M8B nut.
JSM D13A	2TLJ040033R2600	Door stop, natural anodized aluminum. Preassembled with screws and nuts.
JSM D13	2TLJ040033R2500	Door stop for mounting on vertical profiles, galvanized steel. Preassembled with screws, nuts and vibration damper.
JSM D13B	2TLJ040033R2700	Door stop for mounting on horizontal profiles, galvanized steel. Preassembled with screws, nuts and vibration damper.
JSM D21B	2TLJ042023R0500	Magne 1A mounting bracket for installation on hinged doors, natural anodized aluminum. Supplied without Magne 1A Magnetic Lock.
JSM D4H	2TLJ040033R3600	Fittings for Eden sensors for conventional or sliding doors, natural anodized aluminum. Preassembled with screws and nuts. 2 fittings required for a complete unit.
JSM D4J	2TLJ042020R4000	Fittings for Eden sensors for sliding doors flush with fence, natural anodized aluminum. Preassembled with screws and nuts. 1 JSM D4H and 1 JSM D4J are needed for a complete unit.
JSM D4A	2TLJ040033R0900	Fittings for JSNY5 interlock switches for conventional doors, natural anodized aluminum. Preassembled with screws and nuts.
JSM D4AA	2TLJ040033R3400	Fittings for JSNY5 interlock switches for conventional doors, natural anodized aluminum. Preassembled with screws and nuts.
JSM D4B	2TLJ040033R1000	Fittings for JSNY5 interlock switches for sliding doors, galvanized steel. Preassembled with screws and nuts.
JSM D4E	2TLJ040033R1800	Fittings for JSNY7 magnetic switches for conventional doors, natural anodized aluminum. Preassembled with screws and nuts. 2 fittings required for a complete unit.
JSM D4G	2TLJ040033R3300	Fittings for JSNY7 magnetic switches for sliding doors, galvanized steel. Preassembled with screws and nuts. 2 fittings required for a complete unit.
JSM D4D	2TLJ040033R1700	Fittings for JSNY8/JSNY9 interlock switches for conventional doors, galvanized steel. Preassembled with screws and nuts.
JSM D4C	2TLJ040033R1600	Fittings for JSNY8/JSNY9 interlock switches for sliding doors, natural anodized aluminum. Preassembled with screws and nuts.
JSM D4F	2TLJ040033R3000	Fittings for JSNY9 interlock switches for sliding doors, galvanized steel and aluminum. Preassembled with screws and nuts.
JSM D5	2TLJ040033R0400	Suspension wheels for aluminum profile guide rails, galvanized steel.
JSM D6	2TLJ040033R0500	Rectangular sliding elements, polyamide. Preassembled with screws and nuts.
JSM D7	2TLJ040033R0600	Round sliding elements, polyamide. Preassembled with screws and nuts.
JSM D8	2TLJ040033R0700	Sliding elements guide, polyamide. Preassembled with screws and nuts.

*Send requests for quotations to [rfq@jokabsafetyna.com](mailto:rfq@jokabsafetyna.com)*

## Component List - Quick-Guard® Door Components continued

Designation	Ordering Information	Description
JSM D12B	2TLJ040033R2400	Bracket for sliding door guide pin, natural anodized aluminum. Preassembled with screws and nuts.
JSM D12	2TLJ040033R2200	Guide bracket for mounting on vertical profiles for sliding doors, aluminum and PA6-6. Preassembled with screws and nuts.
JSM D12A	2TLJ040033R2300	Guide bracket for mounting on horizontal profiles for sliding doors, aluminum and PA6-6. Preassembled with screws and nuts.
JSM D9-K	2TLJ040033R1100	Guide roller with locking mechanism for conventional door, galvanized steel. Preassembled with angle bracket. Maximum load 60 kg. Includes fastener kit.
JSM D9-AK	2TLJ040033R1300	Guide roller for sliding door, galvanized steel. Preassembled with angle bracket. Maximum load 70 kg. Includes fastener kit.
JSNA-Heavy-Duty Spring-Loaded Caster	2TLA850203R9600	Heavy duty spring-loaded caster for conventional doors with side mount, galvanized steel. Maximum load 100 lbs. Includes fastener kit.
JSM D14	2TLJ040033R2800	Crossbar for conventional doors, natural anodized aluminum. Preassembled with screws and nuts.

## Component List - Quick-Guard® Terminal Caps and Strips

Designation	Ordering Information	Description
JSM L1A	2TLJ040034R0000	Terminal cap for JSM A44A fencing profile, yellow polyamide.
JSM L1B	2TLJ040034R0300	Terminal cap for JSM A44A fencing profile, grey polyamide.
JSM L4A	2TLJ040034R0400	Terminal cap for JSM A4488A fencing profile, yellow polyamide.
JSM L4B	2TLJ040034R0500	Terminal cap for JSM A4488A fencing profile, grey polyamide.
JSM L2	2TLJ040034R0100	Terminal cap for JSM A25 fencing profile, grey polyamide.
JSM L3	2TLJ040034R0200	Terminal cap for JSM A60 fencing profile, grey polyamide.
JSM T3A	2TLJ040037R3100	Narrow cover strip for JSM A4416, JSM A44A, JSM A4488A and JSM A8888 fencing profiles, yellow ABS. Order unit 2.0m.
JSM T3B	2TLJ040037R3200	Narrow cover strip for JSM A4416, JSM A44A, JSM A4488A and JSM A8888 fencing profiles, grey ABS. Order unit 2.0m.

*Send requests for quotations to [rfq@jokabsafetyna.com](mailto:rfq@jokabsafetyna.com)*

## Component List - Quick-Guard® Infill Panels and Accessories

Designation	Ordering Information	Description
JSM YN40W1	2TLJ040040R1300	Welded mesh (40 x 40 mm) infill panel, 864 x 2020 mm, black powder coated 3.5 mm steel wire.
JSM YN40W2	2TLJ040040R1400	Welded mesh (40 x 40 mm) infill panel, 1074 x 1816 mm, black powder coated 3.5 mm steel wire.
JSM YN40W3	2TLJ040040R1500	Welded mesh (40 x 40 mm) infill panel, 1074 x 2016 mm, black powder coated 3.5 mm steel wire.
JSM YN40W4	2TLJ040040R2000	Welded mesh (40 x 40 mm) infill panel, 1474 x 2016 mm, black powder coated 3.5 mm steel wire.
JSM YN40W5	2TLJ040040R2100	Welded mesh (40 x 40 mm) infill panel, 1474 x 1816 mm, black powder coated 3.5 mm steel wire.
JSM YN40W8	2TLJ042020R2500	Welded mesh (40 x 40 mm) infill panel, 1123 x 2020 mm, black powder coated 3.5 mm steel wire.
JSM YN30W1	2TLJ042150R1800	Welded mesh (30 x 30 mm) infill panel, 1123 x 2020 mm, black powder coated 3.5 mm steel wire.
JSM YN30W2	2TLA850103R3100	Welded mesh (30 x 30 mm) infill panel, 1074 x 1520 mm, black powder coated 3.5 mm steel wire.
JSM TZ	2TLA850003R0300	U-shaped flexible black vinyl edge trim with metal core for cutout opening.
JSM NL3	2TLJ040031R0800	Net-Lock for welded mesh with or without outer edge, zinc. Preassembled with JSM S8D screw. Order unit 100 pieces per box.
JSM NL2	2TLJ040031R0600	Net-Lock for welded mesh with outer edge, PA/ABS. Order unit 100 pieces/box.
JSM YPC3AC9	2TLJ040039R2500	Solid plastic infill panel sheet, 3 mm polycarbonate (weld). Cut to size.
JSM YPC5A9	2TLJ050003R0700	Solid plastic infill panel sheet, 5 mm polycarbonate (clear). Cut to size.
JSM PL1A	2TLJ040038R0100	Infill securing strip for panels, black ABS. 842 mm.
JSM PL1B	2TLJ040038R0200	Infill securing strip for panels, black ABS. 1152 mm.
JSM PL1C	2TLJ040038R0300	Infill securing strip for panels, black ABS. 2000 mm.
JSM PL1D	2TLJ040038R0400	Infill securing strip for panels, black ABS. 732 mm.
JSM PL3	2TLJ040038R1100	Infill-lock for panels, zinc. Preassembled with JSM S8D screw. Specify panel thickness.

*Send requests for quotations to [rfq@jokabsafetyna.com](mailto:rfq@jokabsafetyna.com)*

## Component List - Quick-Guard® Accessories

Designation	Ordering Information	Description
JSM S5B	2TLJ041039R0100	Screw to cable ducting, cross-slotted Z (posidrive), bright steel/zinc plated, M5x12. Order unit 100 pieces/box.
JSM S6A	2TLJ041039R0200	Screw for hinge, cross-slotted Z (posidrive), bright steel/zinc plated, M6x12. Order unit 100 pieces/box.
JSM S8A	2TLJ041019R0000	Fixing screw, countersunk, bright steel/zinc plated, M8x16. Order unit 100 pieces/box.
JSM S8C	2TLJ041014R0200	Fixing screw for floor fitting and small angle, bright steel/zinc plated, M8x20. Order unit 100 pieces/box.
JSM S8D	2TLJ041014R0100	Fixing screw, bright steel/zinc plated, M8x16. Order unit 100 pieces/box.
JSM S8E	2TLJ041019R0100	Fixing screw for JSM A56 guide rail, bright steel/zinc plated, M8x12. Order unit 100 pieces/ box.
JSM M4B	2TLJ040035R0700	Locking nut, bright steel/zinc plated, M4. Order unit 100 pieces/box.
JSM M5B	2TLJ040035R0400	Locking nut, bright steel/zinc plated, M5. Order unit 100 pieces/box.
JSM M6B	2TLJ040035R0500	Locking nut, bright steel/zinc plated, M6. Order unit 100 pieces/box.
JSM M8B	2TLJ040035R0600	Locking nut, bright steel/zinc plated, M8. Order unit 100 pieces/box.
JSM X1	2TLJ040033R4300	Cable tie, black nylon, 2.5 - 7.8 mm. Order unit 10 pieces/box.

*Send requests for quotations to [rfq@jokabsafety.com](mailto:rfq@jokabsafety.com)*

This document and any attachments may include suggested specifications, drawings, schematics and similar materials from ABB Inc. Use of such information and/or documentation by the recipient is subject to and conditioned upon your acceptance of the terms of the General Document Disclaimer which can be found at [www.jokabsafety.com](http://www.jokabsafety.com). Your acceptance of the terms of such General Document Disclaimer is conclusively presumed unless you notify ABB in writing of your disagreement with the terms of such Disclaimer immediately upon receipt of this document and you return to ABB all specifications, drawings, schematics and similar materials provided to you by ABB.

# Notes

# Primary Switch Mode Power Supplies CP-E Range

High efficiency of up to 90%!  
 Low power dissipation and low heating!  
 Redundancy units offer true redundancy!

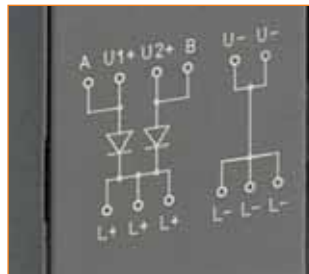

Benefits and Advantages .....	13:2
CP-E 24/0.75 Technical Data .....	13:3
CP-E 24/1.25 Technical Data .....	13:4
CP-E 24/2.5 Technical Data .....	13:5
CP-E 24/5.0 Technical Data .....	13:6
CP-E 24/10.0 Technical Data .....	13:7
CP-E 24/20.0 Technical Data .....	13:8
Dimensional Drawing .....	13:9
Component List and Ordering Information .....	13:9



# Primary Switch Mode Power Supplies CP-E Range

## Benefits and Advantages

- Output voltages 24 V DC  
(Also available in 5 V, 12 V and 48 V DC)
- Adjustable output voltages
- Output currents 0.75 A, 1.25 A, 2.5 A, 5 A, 10 A, 20 A
- Power range 18 W, 30 W, 60 W, 120 W, 240 W, 480 W
- Wide range input or auto select input
- High efficiency of up to 90 %
- Low power dissipation and low heating
- Free convection cooling (no forced cooling with ventilators)
- Ambient temperature range during operation  $-25^{\circ}\text{C}$  to  $+70^{\circ}\text{C}$
- Open-circuit, overload and short-circuit stable
- Integrated input fuse
- U/I characteristic curve on devices  $>18\text{ W}$   
(fold-forward behavior at overload – no switch-off)
- Redundancy units offering true redundancy
- LED(s) for status indication
- Signaling output/contact for output voltage OK
  - Transistor on 24 V devices  $>18\text{ W}$  and  $<120\text{ W}$
  - Relay on 24 V devices  $\geq 120\text{ W}$



## Approvals



### Signalling Output/Contact

The CP-E range 24 V DC devices  $>18\text{ W}$  offer an output/contact for monitoring of the output voltage and remote diagnosis.



### Wide Range Input

Optimized for worldwide applications, the CP-E power supplies can be supplied within a wide range of AC or DC voltage.



### Adjustable Output Voltage

The CP-E range types feature a continuously adjustable output voltage. Thus, they can be optimally adapted to the application, e.g. compensating the voltage drop caused by a long line length.

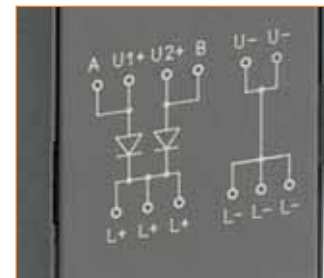



### Redundancy units

For decoupling of parallelized power supply units  $>40\text{ V}$ . Thus, true redundancy can be achieved.



## CP-E 24/0.75 Technical Data

<b>Manufacturer</b>	ABB
<b>Ordering Information</b>	see page 13:9
<b>Input Circuit</b> Rated Input Voltage $U_{IN}$ Input Voltage Range Frequency Range AC Typical Input Current Typical Power Consumption Inrush Current Power Failure Buffering Internal Input Fuse	L, N 100-240 V AC 90-265 V AC 120-370 V DC 47-63 Hz 321 mA (at 115 V AC) 197.4 mA (at 230 V AC) 22.8 W 10 A - max. 3 ms (at 115 V AC) 18 A - max. 3 ms (at 230 V AC) min. 20 ms (at 115 V AC) min. 75 ms (at 230 V AC) 2 A slow-acting/250 V AC
<b>Indication of Operation Status</b> Output Voltage - green LED - red LED	OK:  : output voltage OK LOW:  : output voltage too low
<b>Output Circuit</b> Rated Output Voltage Tolerance of Output Voltage Adjustment Range of Output Voltage Rated Output Power Rated Output Current $I_r$ ( $T_a \leq 60^\circ\text{C}$ ) Derating of Output Current ( $60^\circ\text{C} < T_a \leq 70^\circ\text{C}$ ) Signaling Output for Output Voltage OK (DC OK) Maximum Deviation with load change statical with change of input voltage within the input voltage range Control Time Starting Time after applying Supply Voltage (at $I_r$ ) Response Time (at rated load) Residual Ripple and Switching Peaks (BW = 20 MHz) Parallel Connection Series Connection Resistance to Reverse Feed Power Factor Correction (PFC)	L+, L- 24 V DC +/- 1% 21.6-28.8 V DC 18 W 0.75 A 3% / °C n/a +/- 2% +/- 1% < 2 ms max. 1 s max. 150 ms 50 mV yes (to enable redundancy) yes (to increase voltage) approx. 9 V DC no
<b>Output Circuit (No-Load, Overload and Short-Circuit Behavior)</b> Output Curve Short-Circuit Protection Short-Circuit Behavior Overload Protection No-Load Protection Starting of Capacitive Loads	hiccup-mode continuous short-circuit proof hiccup-mode output power limitation continuous no-load stability not possible
<b>General Data</b> Efficiency Duty Time Dimensions (w x h x d)	typ. 77% 100% 23.9 x 88.5 x 115 mm (0.94 x 3.48 x 4.53 in)

<b>Weight</b>	0.15 kg (0.33 lb)
<b>Material of Enclosure</b>	plastic
<b>Mounting</b> Mounting Position Minimum Distance to Other Units	DIN rail (snap-on mounting without any tools) (EN 60715) horizontal horizontal - 25 mm (0.98 in) vertical - 25 mm (0.98 in)
<b>Degree of Protection enclosure/terminal</b>	IP20/IP20
<b>Protection Class</b>	Category 1
<b>Electrical Connection (Input Circuit/Output Circuit)</b> Wire Size Stripping Length Tightening Torque	0.2-2 mm <sup>2</sup> (24-14 AWG) (fine-strand with wire end ferrule, fine-strand without wire end ferrule or rigid) 6 mm (0.24 in) 0.5-0.6 Nm (input/output)
<b>Environmental Data</b> Ambient Temperature Damp Heat (cyclic) Vibration (sinusoidal) Shock (half-sine)	-25° C to +70° C (operation) -25° C to +60° C (rated load) -25° C to +85° C (storage) 4 x 24 cycles, 40° C, 95% RH (IEC/EN 60068-2-30) 10 m/s <sup>2</sup> , 10 to 500 Hz (IEC/EN 60068-2-6) 40 m/s <sup>2</sup> , 22 ms, all directions (IEC/EN 60068-2-27)
<b>Isolation Data</b> Rated Insulation voltage $U_i$ Pollution Degree	3 kV AC (input circuit/output circuit) 2
<b>Standards</b> Product Standard Low Voltage Directive EMC Directive RoHS Directive Electrical Safety Protective Low Voltage	EN 61204 2006/95/EG 2004/108/EG 2002/95/EG EN 50178, EN 60950-1, UL 609-1, UL 508 SELV (EN 60950)
<b>Electromagnetic Compatibility</b> Interference Immunity electrostatic discharge (ESD) electromagnetic field (HF radiation resistance) fast transients (Burst) powerful impulses (Surge) HF line emission Interference Emission electromagnetic field (HF radiation resistance) HF line emission	(IEC/EN 61000-6-2) Level 4 (8 kV/15kV) (IEC/EN 61000-4-2) Level 3 (10 V/m) (IEC/EN 61000-4-3) Level 4 (4 kV) (IEC/EN 61000-4-4) Level 4 (2kV/4kC) (IEC/EN 61000-4-5) Level 3 (10 V) (IEC/EN 61000-4-6) Class B (IEC/CISPR 22, EN 55022) Class B (IEC/CISPR 22, EN 55022)

Note: Data at  $T_a = 25^\circ\text{C}$ ,  $U_{IN} = V\text{ AC}$  and rated values, if nothing else indicated.

## CP-E 24/1.25 Technical Data

<b>Manufacturer</b>	ABB
<b>Ordering Information</b>	see page 13:9
<b>Input Circuit</b> Rated Input Voltage $U_{IN}$ Input Voltage Range  Frequency Range AC Typical Input Current  Typical Power Consumption Inrush Current  Power Failure Buffering  Internal Input Fuse	L, N 100-240 V AC 85-264 V AC 90-375 V DC  47-63 Hz 543 mA (at 115 V AC) 326.6 mA (at 230 V AC)  36.7 W 20 A - max. 3 ms (at 115 V AC) 40 A - max. 3 ms (at 230 V AC)  min. 20 ms (at 115 V AC) min. 30 ms (at 230 V AC)  2 A slow-acting/250 V AC
<b>Indication of Operation Status</b> Output Voltage - green LED  - red LED	OUTPUT OK:  ; output voltage OK  n/a
<b>Output Circuit</b> Rated Output Voltage Tolerance of Output Voltage Adjustment Range of Output Voltage Rated Output Power Rated Output Current $I_r$ ( $T_a \leq 60^\circ \text{C}$ ) Derating of Output Current ( $60^\circ \text{C} < T_a \leq 70^\circ \text{C}$ ) Signaling Output for Output Voltage OK (DC OK) Maximum Deviation with load change statical with change of input voltage within the input voltage range Control Time Starting Time after applying Supply Voltage (at $I_r$ ) Response Time (at rated load) Residual Ripple and Switching Peaks (BW = 20 MHz) Parallel Connection Series Connection Resistance to Reverse Feed Power Factor Correction (PFC)	L+, L+, L-, L- 24 V DC +/- 1%  24-28 V DC 30 W 1.25 A 2.5% / °C transistor 0.5% 0.5% < 2 ms max. 1 s max. 150 ms 50 mV yes (to enable redundancy) yes (to increase voltage) approx. 18 V DC no
<b>Output Circuit (No-Load, Overload and Short-Circuit Behavior)</b> Output Curve Short-Circuit Protection Short-Circuit Behavior Overload Protection No-Load Protection Starting of Capacitive Loads	U/I curve continuous short-circuit proof continuation with output power limitation output power limitation continuous no-load stability unlimited
<b>General Data</b> Efficiency Duty Time Dimensions (w x h x d)	typ. 86% 100% 43.5 x 88.5 x 115 mm (1.71 x 3.48 x 4.53 in)

<b>Weight</b>	0.29 kg (0.64 lb)
<b>Material of Enclosure</b>	plastic
<b>Mounting</b>  Mounting Position Minimum Distance to Other Units	DIN rail (snap-on mounting without any tools) (EN 60715) horizontal horizontal - 25 mm (0.98 in) vertical - 25 mm (0.98 in)
<b>Degree of Protection enclosure/terminal</b>	IP20/IP20
<b>Protection Class</b>	Category 1
<b>Electrical Connection (Input Circuit/Output Circuit)</b> Wire Size  Stripping Length Tightening Torque	0.2-2 mm <sup>2</sup> (24-14 AWG) (fine-strand with wire end ferrule, fine-strand without wire end ferrule or rigid) 6 mm (0.24 in) 0.5-0.6 Nm (input/output)
<b>Environmental Data</b> Ambient Temperature  Damp Heat (cyclic)  Vibration (sinusoidal)  Shock (half-sine)	-25° C to +70° C (operation) -25° C to +60° C (rated load) -25° C to +85° C (storage) 4 x 24 cycles, 40° C, 95% RH (IEC/EN 60068-2-30) 10 m/s <sup>2</sup> , 10 to 500 Hz (IEC/EN 60068-2-6) 40 m/s <sup>2</sup> , 22 ms, all directions (IEC/EN 60068-2-27)
<b>Isolation Data</b> Rated Insulation voltage $U_i$ Pollution Degree	3 kV AC (input circuit/output circuit) 2
<b>Standards</b> Product Standard Low Voltage Directive EMC Directive RoHS Directive Electrical Safety Protective Low Voltage	EN 61204 2006/95/EG 2004/108/EG 2002/95/EG EN 50178, EN 60950-1, UL 609-1, UL 508 SELV (EN 60950)
<b>Electromagnetic Compatibility</b> Interference Immunity electrostatic discharge (ESD) electromagnetic field (HF radiation resistance) fast transients (Burst) powerful impulses (Surge) HF line emission Interference Emission electromagnetic field (HF radiation resistance) HF line emission	(IEC/EN 61000-6-2) Level 4 (8 kV/15kV) (IEC/EN 61000-4-2)  Level 3 (10 V/m) (IEC/EN 61000-4-3) Level 4 (4 kV) (IEC/EN 61000-4-4) Level 4 (2kV/4kC) (IEC/EN 61000-4-5) Level 3 (10 V) (IEC/EN 61000-4-6)  Class B (IEC/CISPR 22, EN 55022) Class B (IEC/CISPR 22, EN 55022)

Note: Data at  $T_a = 25^\circ \text{C}$ ,  $U_{IN} = V \text{ AC}$  and rated values, if nothing else indicated.

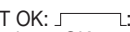

## CP-E 24/2.5 Technical Data

<b>Manufacturer</b>	ABB
<b>Ordering Information</b>	see page 13:9
<b>Input Circuit</b> Rated Input Voltage $U_{IN}$ Input Voltage Range  Frequency Range AC Typical Input Current  Typical Power Consumption Inrush Current  Power Failure Buffering  Internal Input Fuse	L, N 100-240 V AC 85-264 V AC 90-375 V DC  47-63 Hz 1033 mA (at 115 V AC) 570 mA (at 230 V AC)  69.2 W 30 A - max. 3 ms (at 115 V AC) 60 A - max. 3 ms (at 230 V AC)  min. 20 ms (at 115 V AC) min. 30 ms (at 230 V AC)  2 A slow-acting/250 V AC
<b>Indication of Operation Status</b> Output Voltage - green LED  - red LED	OUTPUT OK:  output voltage OK n/a
<b>Output Circuit</b> Rated Output Voltage Tolerance of Output Voltage Adjustment Range of Output Voltage Rated Output Power Rated Output Current $I_r$ ( $T_a \leq 60^\circ\text{C}$ ) Derating of Output Current ( $60^\circ\text{C} < T_a \leq 70^\circ\text{C}$ ) Signaling Output for Output Voltage OK (DC OK) Maximum Deviation with load change statical with change of input voltage within the input voltage range Control Time Starting Time after applying Supply Voltage (at $I_r$ ) Response Time (at rated load) Residual Ripple and Switching Peaks (BW = 20 MHz) Parallel Connection Series Connection Resistance to Reverse Feed Power Factor Correction (PFC)	L+, L+, L-, L- 24 V DC +/- 1%  24-28 V DC 60 W 2.55 A  2.5%/°C  transistor  0.5% 0.5% < 2 ms max. 1 s max. 150 ms 50 mV yes (to enable redundancy) yes (to increase voltage) approx. 35 V DC no
<b>Output Circuit (No-Load, Overload and Short-Circuit Behavior)</b> Output Curve Short-Circuit Protection Short-Circuit Behavior Overload Protection No-Load Protection Starting of Capacitive Loads	U/I curve continuous short-circuit proof continuation with output power limitation output power limitation continuous no-load stability unlimited
<b>General Data</b> Efficiency Duty Time Dimensions (w x h x d)	typ. 89% 100% 43.5 x 88.5 x 115 mm (1.71 x 3.48 x 4.53 in)

<b>Weight</b>	0.36 kg (0.79 lb)
<b>Material of Enclosure</b>	plastic
<b>Mounting</b>  Mounting Position Minimum Distance to Other Units	DIN rail (snap-on mounting without any tools) (EN 60715) horizontal horizontal - 25 mm (0.98 in) vertical - 25 mm (0.98 in)
<b>Degree of Protection enclosure/terminal</b>	IP20/IP20
<b>Protection Class</b>	Category 1
<b>Electrical Connection (Input Circuit/Output Circuit)</b> Wire Size  Stripping Length Tightening Torque	0.2-2 mm <sup>2</sup> (24-14 AWG) (fine-strand with wire end ferrule, fine-strand without wire end ferrule or rigid) 6 mm (0.24 in) 0.5-0.6 Nm (input/output)
<b>Environmental Data</b> Ambient Temperature  Damp Heat (cyclic)  Vibration (sinusoidal)  Shock (half-sine)	-25° C to +70° C (operation) -25° C to +60° C (rated load) -25° C to +85° C (storage) 4 x 24 cycles, 40° C, 95% RH (IEC/EN 60068-2-30) 10 m/s <sup>2</sup> , 10 to 500 Hz (IEC/EN 60068-2-6) 40 m/s <sup>2</sup> , 22 ms, all directions (IEC/EN 60068-2-27)
<b>Isolation Data</b> Rated Insulation voltage $U_i$ Pollution Degree	3 kV AC (input circuit/output circuit) 2
<b>Standards</b> Product Standard Low Voltage Directive EMC Directive RoHS Directive Electrical Safety Protective Low Voltage	EN 61204 2006/95/EG 2004/108/EG 2002/95/EG EN 50178, EN 60950-1, UL 609-1, UL 508 SELV (EN 60950)
<b>Electromagnetic Compatibility</b> Interference Immunity electrostatic discharge (ESD) electromagnetic field (HF radiation resistance) fast transients (Burst) powerful impulses (Surge) HF line emission Interference Emission electromagnetic field (HF radiation resistance) HF line emission	(IEC/EN 61000-6-2) Level 4 (8 kV/15kV) (IEC/EN 61000-4-2)  Level 3 (10 V/m) (IEC/EN 61000-4-3) Level 4 (4 kV) (IEC/EN 61000-4-4) Level 4 (2kV/4kC) (IEC/EN 61000-4-5) Level 3 (10 V) (IEC/EN 61000-4-6)  Class B (IEC/CISPR 22, EN 55022) Class B (IEC/CISPR 22, EN 55022)

Note: Data at  $T_a = 25^\circ\text{C}$ ,  $U_{IN} = V\text{ AC}$  and rated values, if nothing else indicated

## CP-E 24/5.0 Technical Data

<b>Manufacturer</b>	ABB
<b>Ordering Information</b>	see page 13:9
<b>Input Circuit</b> Rated Input Voltage $U_{IN}$ Input Voltage Range	L, N 115-230 V AC auto select 90-132 V AC 186-264 V DC 210-370 V DC
Frequency Range AC Typical Input Current	47-63 Hz 2.8 A (at 115 V AC) 1.4 A (at 230 V AC)
Typical Power Consumption Inrush Current	140 W 24 A - max. 3 ms (at 115 V AC) 48 A - max. 3 ms (at 230 V AC)
Power Failure Buffering	min. 25 ms (at 115 V AC) min. 30 ms (at 230 V AC)
Internal Input Fuse	3.15 A slow-acting/250 V AC
<b>Indication of Operation Status</b> Output Voltage - green LED	OUTPUT OK:  : output voltage OK
- red LED	OUTPUT LOW:  : output voltage too low
<b>Output Circuit</b> Rated Output Voltage Tolerance of Output Voltage Adjustment Range of Output Voltage Rated Output Power Rated Output Current $I_r$ ( $T_a \leq 60^\circ\text{C}$ ) Derating of Output Current ( $60^\circ\text{C} < T_a \leq 70^\circ\text{C}$ ) Signaling Output for Output Voltage OK (13-14) Maximum Deviation with load change statical  with change of input voltage within the input voltage range Control Time Starting Time after applying Supply Voltage (at $I_r$ ) Response Time (at rated load) Residual Ripple and Switching Peaks (BW = 20 MHz) Parallel Connection  Series Connection  Resistance to Reverse Feed Power Factor Correction (PFC)	L+, L+, L-, L- 24 V DC 0 to 1% 22.5-28.5 V DC 120 W 5 A 2.5% / °C relay (max. 60 V DC, 0.3 A) +/- 1% (single mode) +/- 5% (parallel mode) +/- 0.5% < 2 ms max. 1 s max. 150 ms 50 mV configurable up to 3 devices (to increase power) yes, up to 2 devices (to increase power) approx. 35 V DC yes
<b>Output Circuit (No-Load, Overload and Short-Circuit Behavior)</b> Output Curve Short-Circuit Protection Short-Circuit Behavior Overload Protection No-Load Protection Starting of Capacitive Loads	U/I curve continuous short-circuit proof continuation with output power limitation output power limitation continuous no-load stability unlimited
<b>General Data</b> Efficiency Duty Time Dimensions (w x h x d)	typ. 86% 100% 63.2 x 123.6 x 123.6 mm (2.49 x 4.87 x 4.87 in)

<b>Weight</b>	1 kg (2.20 lb)
<b>Material of Enclosure</b>	metal
<b>Mounting</b>  Mounting Position Minimum Distance to Other Units	DIN rail (snap-on mounting without any tools) (EN 60715) horizontal horizontal - 25 mm (0.98 in) vertical - 25 mm (0.98 in)
<b>Degree of Protection enclosure/terminal</b>	IP20/IP20
<b>Protection Class</b>	Category 1
<b>Electrical Connection (Input Circuit/Output Circuit)</b> Wire Size  Stripping Length Tightening Torque	0.2-4 mm <sup>2</sup> (24-11 AWG) (fine-strand with wire end ferrule) 0.2-6 mm <sup>2</sup> (24-10 AWG) (fine-strand without wire end ferrule or rigid) 8 mm (0.31 in) 1-0.6 Nm (input/output)
<b>Environmental Data</b> Ambient Temperature  Damp Heat (cyclic)  Vibration (sinusoidal)  Shock (half-sine)	-25° C to +70° C (operation) -25° C to +60° C (rated load) -25° C to +85° C (storage) 95% without condensation (IEC/EN 60068-2-30) 10-500 Hz, 2G, along X, Y, Z each axis, 60 min. for each axis (IEC/EN 60068-2-6) 15 G, 11 ms, 3 axes, 6 faces, 3 times for each face (IEC/EN 60068-2-27)
<b>Isolation Data</b> Rated Insulation voltage $U_i$ Pollution Degree	3 kV AC (input circuit/output circuit) 2
<b>Standards</b> Product Standard Low Voltage Directive EMC Directive RoHS Directive Electrical Safety Protective Low Voltage	EN 61204-3 2006/95/EG 2004/108/EG 2002/95/EG IEC/EN 60950-1 SELV
<b>Electromagnetic Compatibility</b> Interference Immunity electrostatic discharge (ESD) radiated, radio frequency, electromagnetic field electrical fast transients/burst surge  conducted disturbances, induced by radio-frequency fields  Interference Emission electromagnetic field (HF radiation resistance) HF line emission	(IEC/EN 61000-6-2) Level 4 (IEC/EN 61000-4-2)  Level 3 (IEC/EN 61000-4-3) Level 4 (IEC/EN 61000-4-4) L-N Level 3, L/N-FG Level 4 (IEC/EN 61000-4-5)  Level 3 (10 V) (IEC/EN 61000-4-6)  Class B (IEC/CISPR 22, EN 55022) Class B (IEC/CISPR 22, EN 55022)

Note: Data at  $T_a = 25^\circ\text{C}$ ,  $U_{IN} = V\text{ AC}$  and rated values, if nothing else indicated

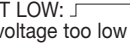

## CP-E 24/10.0 Technical Data

<b>Manufacturer</b>	ABB
<b>Ordering Information</b>	see page 13:9
<b>Input Circuit</b> Rated Input Voltage $U_{IN}$ Input Voltage Range  Frequency Range AC Typical Input Current  Typical Power Consumption Inrush Current  Power Failure Buffering  Internal Input Fuse	L, N 115-230 V AC auto select 93-132 V AC 186-264 V DC 210-370 V DC 47-63 Hz 5.4 A (at 115 V AC) 2.2 A (at 230 V AC) 270 W 30 A - max. 3 ms (at 115 V AC) 60 A - max. 3 ms (at 230 V AC) min. 25 ms (at 115 V AC) min. 30 ms (at 230 V AC) 6.3 A slow-acting/250 V AC
<b>Indication of Operation Status</b> Output Voltage - green LED  - red LED	OUTPUT OK:  : output voltage OK OUTPUT LOW:  : output voltage too low
<b>Output Circuit</b> Rated Output Voltage Tolerance of Output Voltage Adjustment Range of Output Voltage Rated Output Power Rated Output Current $I_r$ ( $T_a \leq 60^\circ\text{C}$ ) Derating of Output Current ( $60^\circ\text{C} < T_a \leq 70^\circ\text{C}$ ) Signaling Output for Output Voltage OK (13-14) Maximum Deviation with load change statical  with change of input voltage within the input voltage range Control Time Starting Time after applying Supply Voltage (at $I_r$ ) Response Time (at rated load) Residual Ripple and Switching Peaks (BW = 20 MHz) Parallel Connection  Series Connection  Resistance to Reverse Feed Power Factor Correction (PFC)	L+, L+, L-, L- 24 V DC 0 to 1% 22.5-28.5 V DC 240 W 10 A 2.5%/°C relay (max. 60 V DC, 0.3 A) +/- 1% (single mode) +/- 5% (parallel mode) +/- 0.5% < 2 ms max. 1 s max. 150 ms 100 mV configurable up to 3 devices (to increase power) reduction: (number of devices x $I_r$ x) x 0.9 yes, up to 2 devices (to increase power) approx. 35 V DC yes
<b>Output Circuit (No-Load, Overload and Short-Circuit Behavior)</b> Output Curve Short-Circuit Protection Short-Circuit Behavior Overload Protection No-Load Protection Starting of Capacitive Loads	U/I curve continuous short-circuit proof continuation with output power limitation output power limitation continuous no-load stability unlimited
<b>General Data</b> Efficiency Duty Time Dimensions (w x h x d)	typ. 89% 100% 83 x 123.6 x 123.6 mm (3.27 x 4.87 x 4.87 in)

<b>Weight</b>	1.36 kg (3.01 lb)
<b>Material of Enclosure</b>	metal
<b>Mounting</b>  Mounting Position Minimum Distance to Other Units	DIN rail (snap-on mounting without any tools) (EN 60715) horizontal horizontal - 25 mm (0.98 in) vertical - 25 mm (0.98 in)
<b>Degree of Protection enclosure/terminal</b>	IP20/IP20
<b>Protection Class</b>	Category 1
<b>Electrical Connection (Input Circuit/Output Circuit)</b> Wire Size  Stripping Length Tightening Torque	0.2-4 mm <sup>2</sup> (24-11 AWG) (fine-strand with wire end ferrule) 0.2-6 mm <sup>2</sup> (24-10 AWG) (fine-strand without wire end ferrule or rigid) 8 mm (0.31 in) 1-0.6 Nm (input/output)
<b>Environmental Data</b> Ambient Temperature  Damp Heat (cyclic)  Vibration (sinusoidal)  Shock (half-sine)	-25° C to +70° C (operation) -25° C to +60° C (rated load) -25° C to +85° C (storage) 95% without condensation (IEC/EN 60068-2-30) 10-500 Hz, 2G, along X, Y, Z each axis, 60 min. for each axis (IEC/EN 60068-2-6) 15 G, 11 ms, 3 axes, 6 faces, 3 times for each face (IEC/EN 60068-2-27)
<b>Isolation Data</b> Rated Insulation voltage $U_i$ Pollution Degree	3 kV AC (input circuit/output circuit) 2
<b>Standards</b> Product Standard Low Voltage Directive EMC Directive RoHS Directive Electrical Safety Protective Low Voltage	EN 61204-3 2006/95/EG 2004/108/EG 2002/95/EG IEC/EN 60950-1 SELV
<b>Electromagnetic Compatibility</b> Interference Immunity electrostatic discharge (ESD) radiated, radio frequency, electromagnetic field electrical fast transients/burst surge  conducted disturbances, induced by radio-frequency fields  Interference Emission electromagnetic field (HF radiation resistance) HF line emission	(IEC/EN 61000-6-2) Level 4 (IEC/EN 61000-4-2) Level 3 (IEC/EN 61000-4-3) Level 4 (IEC/EN 61000-4-4) L-N Level 3, L/N-FG Level 4 (IEC/EN 61000-4-5) Level 3 (10 V) (IEC/EN 61000-4-6) Class B (IEC/CISPR 22, EN 55022) Class B (IEC/CISPR 22, EN 55022)

Note: Data at  $T_a = 25^\circ\text{C}$ ,  $U_{IN} = V\text{ AC}$  and rated values, if nothing else indicated

## CP-E 24/20.0 Technical Data

<b>Manufacturer</b>	ABB
<b>Ordering Information</b>	see page 13:9
<b>Input Circuit</b> Rated Input Voltage $U_{IN}$ Input Voltage Range  Frequency Range AC Typical Input Current  Typical Power Consumption Inrush Current  Power Failure Buffering  Internal Input Fuse	L, N 115-230 V AC 90-264 V AC 120-370 V DC 47-63 Hz 7 A (at 115 V AC) 3.5 A (at 230 V AC) 539 W 25 A - max. 3 ms (at 115 V AC) 50 A - max. 3 ms (at 230 V AC) min. 30 ms (at 115 V AC) min. 30 ms (at 230 V AC) 10 A slow-acting/250 V AC
<b>Indication of Operation Status</b> Output Voltage - green LED  - red LED	OUTPUT OK:  : output voltage OK  OUTPUT LOW:  : output voltage too low
<b>Output Circuit</b> Rated Output Voltage Tolerance of Output Voltage Adjustment Range of Output Voltage Rated Output Power Rated Output Current $I_r$ ( $T_a \leq 60^\circ\text{C}$ ) Derating of Output Current ( $60^\circ\text{C} < T_a \leq 70^\circ\text{C}$ ) Signaling Output for Output Voltage OK (13-14) Maximum Deviation with load change statical  with change of input voltage within the input voltage range Control Time Starting Time after applying Supply Voltage (at $I_r$ ) Response Time (at rated load) Residual Ripple and Switching Peaks (BW = 20 MHz) Parallel Connection  Series Connection  Resistance to Reverse Feed Power Factor Correction (PFC)	L+, L+, L-, L- 24 V DC 0 to 1% 22.5-28.5 V DC 480 W 20 A 2.5% / °C relay (max. 60 V DC, 0.3 A) +/- 0.5% (single mode) +/- 5% (parallel mode) +/- 0.5% < 2 ms max. 1 s max. 150 ms 100 mV configurable up to 3 devices (to increase power) reduction: (number of devices x $I_r$ x) x 0.9 yes, up to 2 devices (to increase power) approx. 35 V DC yes
<b>Output Circuit (No-Load, Overload and Short-Circuit Behavior)</b> Output Curve Short-Circuit Protection Short-Circuit Behavior Overload Protection No-Load Protection Starting of Capacitive Loads	U/I curve continuous short-circuit proof continuation with output power limitation output power limitation continuous no-load stability unlimited
<b>General Data</b> Efficiency Duty Time Dimensions (w x h x d)	typ. 89% 100% 175 x 123.6 x 123.6 mm (6.89 x 4.87 x 4.87 in)

<b>Weight</b>	1.9 kg (4.19 lb)
<b>Material of Enclosure</b>	metal
<b>Mounting</b>  Mounting Position Minimum Distance to Other Units	DIN rail (snap-on mounting without any tools) (EN 60715) horizontal horizontal - 25 mm (0.98 in) vertical - 25 mm (0.98 in)
<b>Degree of Protection enclosure/terminal</b>	IP20/IP20
<b>Protection Class</b>	Category 1
<b>Electrical Connection (Input Circuit/Output Circuit)</b> Wire Size  Stripping Length Tightening Torque	0.2-4 mm <sup>2</sup> (24-11 AWG) (fine-strand with wire end ferrule) 0.2-6 mm <sup>2</sup> (24-10 AWG) (fine-strand without wire end ferrule or rigid) 8 mm (0.31 in) 1-0.6 Nm (input/output)
<b>Environmental Data</b> Ambient Temperature  Damp Heat (cyclic)  Vibration (sinusoidal)  Shock (half-sine)	-25° C to +70° C (operation) -25° C to +60° C (rated load) -25° C to +85° C (storage) 95% without condensation (IEC/EN 60068-2-30) 10-500 Hz, 2G, along X, Y, Z each axis, 60 min. for each axis (IEC/EN 60068-2-6) 15 G, 11 ms, 3 axes, 6 faces, 3 times for each face (IEC/EN 60068-2-27)
<b>Isolation Data</b> Rated Insulation voltage $U_i$ Pollution Degree	3 kV AC (input circuit/output circuit) 2
<b>Standards</b> Product Standard Low Voltage Directive EMC Directive RoHS Directive Electrical Safety Protective Low Voltage	EN 61204-3 2006/95/EG 2004/108/EG 2002/95/EG IEC/EN 60950-1 SELV
<b>Electromagnetic Compatibility</b> Interference Immunity electrostatic discharge (ESD) radiated, radio frequency, electromagnetic field electrical fast transients/burst surge  conducted disturbances, induced by radio-frequency fields  Interference Emission electromagnetic field (HF radiation resistance) HF line emission	(IEC/EN 61000-6-2) Level 4 (IEC/EN 61000-4-2)  Level 3 (IEC/EN 61000-4-3) Level 4 (IEC/EN 61000-4-4) L-N Level 3, L/N-FG Level 4 (IEC/EN 61000-4-5)  Level 3 (10 V) (IEC/EN 61000-4-6)  Class B (IEC/CISPR 22, EN 55022) Class B (IEC/CISPR 22, EN 55022)

Note: Data at  $T_a = 25^\circ\text{C}$ ,  $U_{IN} = V\text{ AC}$  and rated values, if nothing else indicated

## Dimensional Drawings

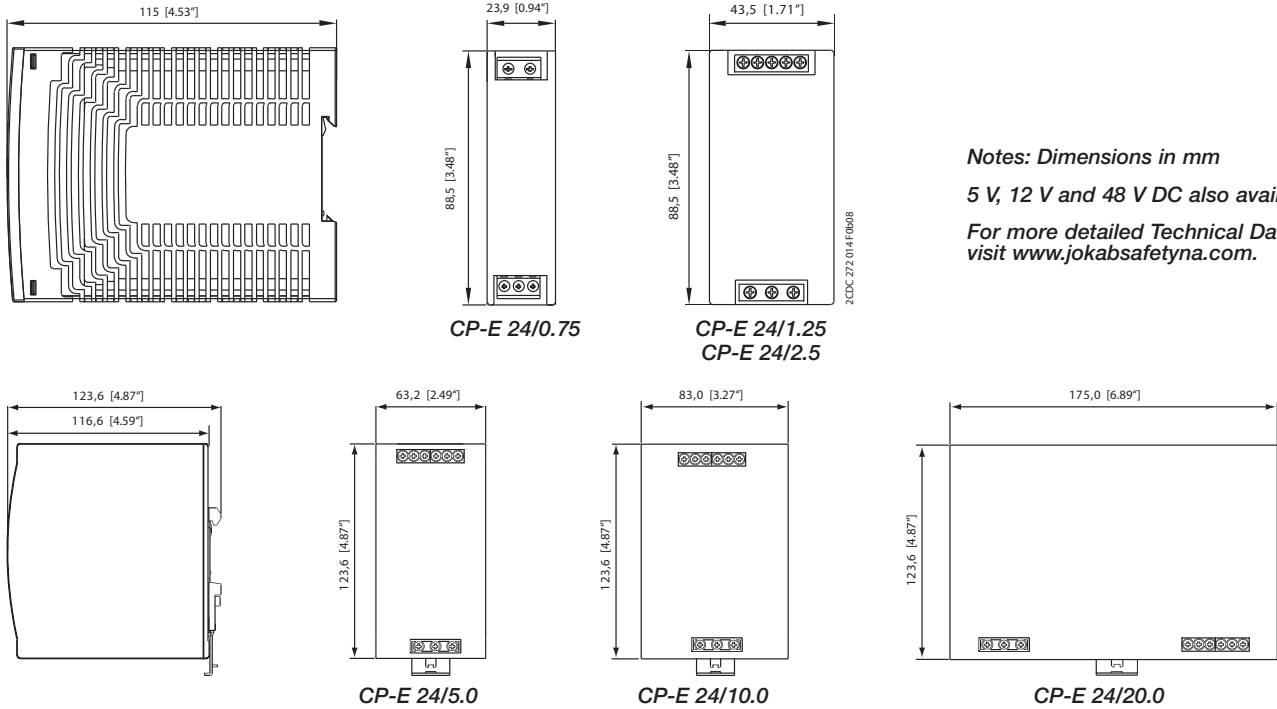

## Component List - Primary Switch Mode Power Supplies CP-E Range

Designation	Article Number	Description
CP-E 24/0.75	1SVR427030R0000	Rated input voltage 100-240 V AC Rated output voltage/current 24 V DC/0.75 A Packaged in single units—weight 0.15 kg (0.33 lb)
CP-E 24/1.25	1SVR427031R0000	Rated input voltage 100-240 V AC Rated output voltage/current 24 V DC/1.25 A Packaged in single units—weight 0.29 kg (0.64 lb)
CP-E 24/2.5	1SVR427032R0000	Rated input voltage 100-240 V AC Rated output voltage/current 24 V DC/2.5 A Packaged in single units—weight 0.36 kg (0.79 lb)
CP-E 24/5.0	1SVR427034R0000	Rated input voltage 115-230 V AC auto select Rated output voltage/current 24 V DC/5 A Packaged in single units—weight 1.00 kg (2.20 lb)
CP-E 24/10.0	1SVR427035R0000	Rated input voltage 115-230 V AC auto select Rated output voltage/current 24 V DC/10 A Packaged in single units—weight 1.36 kg (3.01 lb)
CP-E 24/20.0	1SVR427036R0000	Rated input voltage 115-230 V AC Rated output voltage/current 24 V DC/20 A Packaged in single units—weight 1.90 kg (4.19 lb)

## Notes

This document and any attachments may include suggested specifications, drawings, schematics and similar materials from ABB Inc. Use of such information and/or documentation by the recipient is subject to and conditioned upon your acceptance of the terms of the General Document Disclaimer which can be found at [www.jokabsafety.com](http://www.jokabsafety.com). Your acceptance of the terms of such General Document Disclaimer is conclusively presumed unless you notify ABB in writing of your disagreement with the terms of such Disclaimer immediately upon receipt of this document and you return to ABB all specifications, drawings, schematics and similar materials provided to you by ABB.



# Block Contactors

Block type design controls 3-phase motors!  
 Full line of contactors for varied applications!  
 Wide range of accessories available!

A., AL., AE., AF... 3-Pole Contactors	
a.c. circuit switching .....	14:2
Main Accessories.....	14:5
Protection of 3-Phase Motor .....	14:6
A 9 ... A 110 3-Pole Contactors.....	14:7
Accessory Fitting Details .....	14:9
A 145 ... AF 1650 3-Pole Contactors.....	14:10
Accessory Fitting Details .....	14:12
A 9 ... AE 110, AL...Z... 3-Pole Contactors.....	14:13
Accessory Fitting Details .....	14:15
AF 50 ... AF 100 3-Pole Contactors.....	14:16
AF 145 ... AF 1650 3-Pole Contactors.....	14:18
GA 75, GAE 75 Contactors.....	14:20
Contactor Selection .....	14:22
Auxiliary Contacts for Safety Circuits .....	14:24
Technical Data.....	14:25
Contactor Electrical Durability and Utilization Categories.....	14:37
Influence of the Length of Conductors used in Contactor Control Circuit.....	14:43



# A..., AL..., AE..., AF... 3-Pole Contactors

## Switching of 3-Phase Cage Motors

### AC-3 utilization category



When making the motor current is about  $6 \times I_n$  breaking while the motor is running at  $I_n$  motor F.L.C.

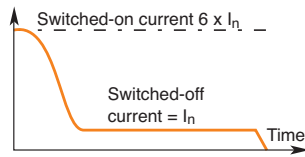

## Switching of Resistive Circuits

### AC-1 utilization category



When making the switched-on current is equal to the  $I_n$  load rated current with  $\cos \phi \geq 0.95$ .

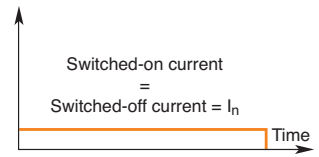

Contactor Type	AC-3 IEC Power Rating $0 \leq 55^\circ \text{C}, 400 \text{V}$	AC-3 IEC Rated Operational Current $0 \leq 55^\circ \text{C}, 400 \text{V}$		
		$0 \leq 55^\circ \text{C}, 415 \text{V}$	$0 \leq 55^\circ \text{C}, 415 \text{V}$	$0 \leq 55^\circ \text{C}, 690 \text{V}$
A 9/AL 9	4 kW	9 A	9 A	7 A
A 12/AL 12	5.5 kW	12 A	12 A	9 A
A 16/AL 16	7.5 kW	17 A	17 A	10 A
A 26/AL 26	11 kW	26 A	26 A	17 A*
A 30/AL 30	15 kW	32 A	32 A	21 A*
A 40/AL 40	18.5 kW	37 A	37 A	25 A*
A 50/AE 50	22 kW	50 A	50 A	35 A
A 63/AE 63	30 kW	65 A	65 A	43 A
A 75/AE 75	37 kW	75 A	75 A	46 A
A 95/AE 95	45 kW	96 A	96 A	65 A
A 110/AE 110	55 kW	110 A	110 A	82 A
A 145/AF 145	75 kW	145 A	145 A	120 A
A 185/AF 185	90 kW	185 A	185 A	170 A
A 210/AF 210	110 kW	210 A	210 A	210 A
A 260/AF 260	140 kW	260 A	260 A	220 A
A 300/AF 300	160 kW	305 A	300 A	280 A
AF 400	200 kW	400 A	400 A	350 A
AF 460	250 kW	460 A	460 A	400 A
AF 580	315 kW	580 A	580 A	500 A
AF 750	400 kW	750 A	750 A	650 A
AF 1350	475 kW	860 A	860 A	800 A
AF 1650	560 kW	1050 A	1050 A	950 A

## a.c. circuit switching

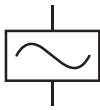

a.c. Control Supply Range  
A., AF... Contactors

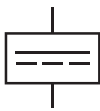

d.c. Control Supply Range  
AL., AE., AF... Contactors

### HOW TO ORDER:

Select contactor Type + Select Contactor Coil Voltage\*  
according to Control Circuit Supply

*Note: The AF contactor range,  
with a.c./d.c. Electronic Coil Interface,  
is available from AF 50 up to AF 1650.*

AC-1 Rated Operational Current		With Conductor 0 ≤ 70° C, 690 V	Rated Operation Cross-Sectional Area	Voltage
0 ≤ 40° C, 690 V	0 ≤ 55° C, 690 V			
25 A	22 A	18 A	2.5 mm <sup>2</sup>	690 V
27 A	25 A	20 A	4 mm <sup>2</sup>	690 V
30 A	27 A	23 A	4 mm <sup>2</sup>	690 V
45 A	40 A	32 A	6 mm <sup>2</sup>	690 V
55 A	55 A	39 A	10 mm <sup>2</sup>	690 V
60 A	60 A	42 A	16 mm <sup>2</sup>	690 V
100 A	85 A	70 A	35 mm <sup>2</sup>	1000 V
115 A	95 A	80 A	50 mm <sup>2</sup>	1000 V
125 A	105 A	85 A	50 mm <sup>2</sup>	1000 V
145 A	135 A	115 A	50 mm <sup>2</sup>	1000 V
160 A	145 A	130 A	70 mm <sup>2</sup>	1000 V
250 A	230 A	180 A	120 mm <sup>2</sup>	1000 V
275 A	250 A	180 A	150 mm <sup>2</sup>	1000 V
350 A	300 A	240 A	185 mm <sup>2</sup>	690 V
400 A	350 A	290 A	240 mm <sup>2</sup>	690 V
500 A	400 A	325 A	300 mm <sup>2</sup>	690 V
600 A	500 A	400 A	2 x 185 mm <sup>2</sup>	1000 V
700 A	600 A	480 A	2 x 240 mm <sup>2</sup>	1000 V
800 A	700 A	580 A	2 x 240 mm <sup>2</sup>	1000 V
1050 A	875 A	720 A	bar/mm 2 x 50 x 8	1000 V
1350 A	1150 A	1000 A	bar/mm 2// 100 x 5	1000 V
1650 A	1450 A	1270 A	bar/mm 3// 100 x 5	1000 V

# A..., AL..., AE..., AF... 3-Pole Contactors

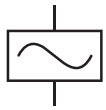

a.c. Control Supply Range  
A..., AF... Contactors

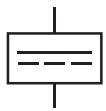

d.c. Control Supply Range  
AL..., AE..., AF... Contactors

## HOW TO ORDER:

Select contactor Type + Select Contactor Coil Voltage\*  
according to Control Circuit Supply

*Note: The AF contactor range,  
with a.c./d.c. Electronic Coil Interface,  
is available from AF 50 up to AF 1650.*

Contactor Type	UL/CSA 3-Phase Motor-Rating	UL/CSA General Use Amp-Rating	Nema Size	a.c. Control Supply Range Types	d.c. Control Supply Range Types
A 9/AL 9	480 V - 5 hp	600 V - 21 A	00	A 9-30-10	AL 9-30-10
A 12/AL 12	480 V - 7.5 hp	600 V - 25 A	0	A 12-30-10	AL 12-30-10
A 16/AL 16	480 V - 10 hp	600 V - 30 A	-	A 16-30-10	AL 16-30-10
A 26/AL 26	480 V - 20 hp	600 V - 40 A	1	A 26-30-10	AL 26-30-10
A 30/AL 30	480 V - 25 hp	600 V - 50 A	1P	A 30-30-10	AL 30-30-10
A 40/AL 40	480 V - 30 hp	600 V - 60 A	-	A 40-30-10	AL 40-30-10
A 50/AE 50	480 V - 40 hp	600 V - 80 A	2	A 50-30-00	AE 50-30-00
A 63/AE 63	480 V - 60 hp	600 V - 90 A	-	A 63-30-00	AE 63-30-00
A 75/AE 75	480 V - 60 hp	600 V - 105 A	3	A 75-30-00	AE 75-30-00
A 95/AE 95	480 V - 60 hp	600 V - 125 A	-	A 95-30-00	AE 95-30-00
A 110/AE 110	480 V - 75 hp	600 V - 140 A	-	A 110-30-00	AE 110-30-00
A 145/AF 145	480 V - 100 hp	600 V - 230 A	4	A 145-30-11	AF 145-30-11
A 185/AF 185	480 V - 125 hp	600 V - 250 A	-	A 185-30-11	AF 185-30-11
A 210/AF 210	480 V - 150 hp	600 V - 300 A	-	A 210-30-11	AF 210-30-11
A 260/AF 260	480 V - 200 hp	600 V - 350 A	5	A 260-30-11	AF 260-30-11
A 300/AF 300	480 V - 250 hp	600 V - 400 A	-	A 300-30-11	AF 300-30-11
AF 400	480 V - 350 hp	600 V - 550 A	-	AF 400-30-11	AF 400-30-11
AF 460	480 V - 400 hp	600 V - 650 A	6	AF 460-30-11	AF 460-30-11
AF 580	480 V - 500 hp	600 V - 750 A	-	AF 580-30-11	AF 580-30-11
AF 750	480 V - 600 hp	600 V - 900 A	7	AF 750-30-11	AF 750-30-11
AF 1350	480 V - 800 hp	600 V - 1350 A	-	AF 1350-30-11	AF 1350-30-11
AF 1650	480 V - 900 hp	600 V - 1650 A	8	AF 1650-30-11	AF 1650-30-11

# A..., AL..., AE..., AF... Main Accessories

**HOW TO ORDER: Select Accessory Type and Quote Required Data in Plain Text**

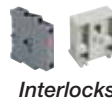

Notes: \* CA 5-... 1-pole, front mounting/CAL... 2-pole, side mounting

\*\* DA - direct timing, front mounting

IA - inverse timing, front mounting

S - direct timing, separate mounting (electronic Timers)

Pneumatic Timers for A..., AE..., AF... contactors only

Supply Voltages for Timers: 24 V a.c./d.c., 110-120 V a.c., 220-240 V a.c. and 380-440 V a.c.

Auxiliary Contacts*	Timers** Pneumatic	Timers** Electronic	Interlocks		Surge Suppressors		
			Mech/Elect	Mechanical	RV...	RC...	RT...
CA 5-10 (1xN.O.)	TP40 DA, TP180 DA/TP40 IA, TP180 IA	TE5S	VE 5-1	VM 5-1	RV 5	RC 5-1	RT 5
CA 5-10 (1xN.O.)	TP40 DA, TP180 DA/TP40 IA, TP180 IA	TE5S	VE 5-1	VM 5-1	RV 5	RC 5-1	RT 5
CA 5-10 (1xN.O.)	TP40 DA, TP180 DA/TP40 IA, TP180 IA	TE5S	VE 5-1	VM 5-1	RV 5	RC 5-1	RT 5
CA 5-01 (1xN.C.)	TP40 DA, TP180 DA/TP40 IA, TP180 IA	TE5S	VE 5-1	VM 5-1	RV 5	RC 5-1	RT 5
CA 5-01 (1xN.C.)	TP40 DA, TP180 DA/TP40 IA, TP180 IA	TE5S	VE 5-1	VM 5-1	RV 5	RC 5-1	RT 5
CA 5-01 (1xN.C.)	TP40 DA, TP180 DA/TP40 IA, TP180 IA	TE5S	VE 5-1	VM 5-1	RV 5	RC 5-1	RT 5
CAL 5-11 (1xN.O. + 1xN.C.)	TP40 DA, TP180 DA/TP40 IA, TP180 IA	TE5S	VE 5-2	-	RV 5	RC 5-2	RT 5
CAL 5-11 (1xN.O. + 1xN.C.)	TP40 DA, TP180 DA/TP40 IA, TP180 IA	TE5S	VE 5-2	-	RV 5	RC 5-2	RT 5
CAL 5-11 (1xN.O. + 1xN.C.)	TP40 DA, TP180 DA/TP40 IA, TP180 IA	TE5S	VE 5-2	-	RV 5	RC 5-2	RT 5
CAL 18-11 (1xN.O. + 1xN.C.) 1st block CAL 18-11B (1xN.O. + 1xN.C.) 2nd block	-	TE5S	VE 5-2	-	RV 5	RC 5-2	RT 5
CAL 18-11 (1xN.O. + 1xN.C.) 1st block CAL 18-11B (1xN.O. + 1xN.C.) 2nd block	-	TE5S	VE 5-2	-	RV 5	RC 5-2	RT 5
CAL 18-11 (1xN.O. + 1xN.C.) 1st block CAL 18-11B (1xN.O. + 1xN.C.) 2nd block	-	TE5S	-	VM 300H	<i>The AF 50...AF 1650 contactors are equipped with a built-in electronic coil interface which eliminates the need of extra surge suppressors. For A 145...A 300, use RC-EH 300.</i>		
CAL 18-11 (1xN.O. + 1xN.C.) 1st block CAL 18-11B (1xN.O. + 1xN.C.) 2nd block	-	TE5S	-	VM 300H			
CAL 18-11 (1xN.O. + 1xN.C.) 1st block CAL 18-11B (1xN.O. + 1xN.C.) 2nd block	-	TE5S	-	VM 300H			
CAL 18-11 (1xN.O. + 1xN.C.) 1st block CAL 18-11B (1xN.O. + 1xN.C.) 2nd block	-	TE5S	-	VM 300H			
CAL 18-11 (1xN.O. + 1xN.C.) 1st block CAL 18-11B (1xN.O. + 1xN.C.) 2nd block	-	TE5S	-	VM 300H			
CAL 18-11 (1xN.O. + 1xN.C.) 1st block CAL 18-11B (1xN.O. + 1xN.C.) 2nd block	-	TE5S	-	VM 750H			
CAL 18-11 (1xN.O. + 1xN.C.) 1st block CAL 18-11B (1xN.O. + 1xN.C.) 2nd block	-	TE5S	-	VM 750H			
CAL 18-11 (1xN.O. + 1xN.C.) 1st block CAL 18-11B (1xN.O. + 1xN.C.) 2nd block	-	TE5S	-	VM 750H			
CAL 18-11 (1xN.O. + 1xN.C.) 1st block CAL 18-11B (1xN.O. + 1xN.C.) 2nd block	-	TE5S	-	VM 750H			
CAL 18-11 (1xN.O. + 1xN.C.) 1st block CAL 18-11B (1xN.O. + 1xN.C.) 2nd block	-	TE5S	-	VM 1650H			
CAL 18-11 (1xN.O. + 1xN.C.) 1st block CAL 18-11B (1xN.O. + 1xN.C.) 2nd block	-	TE5S	-	VM 1650H			

# A..., AL..., AE..., AF... Protection of 3-Phase Motors

HOW TO ORDER: Select O/L Relay Type and Setting Range according to motor F.L.C.



Notes: \* TA...DU... - Thermal O/L Relay  
\*\* E...DU... - Electronic O/L Relay

Standard starting time 2...10 s

Tripping class 10 A

Contactor Type	Thermal O/L Relay* (setting range in Amps)	Electronic O/L Relay** (setting range in Amps)
A 9/AL 9	TA 25 DU...	E 16 DU...-10
A 12/AL 12	0.10 - 0.16 1.3 - 1.8 6.0 - 8.5 0.16 - 0.25 1.7 - 2.4 7.5 - 11	22 - 32 29 - 42 0.1 - 0.32 2.0 - 6.3 0.3 - 1.0 5.7 - 18.9 0.9 - 2.7
A 16/AL 16	0.25 - 0.40 2.2 - 3.1 10 - 14 0.40 - 0.63 2.8 - 4.0 13 - 19	
A 26/AL 26	0.63 - 1.0 3.5 - 5.0 18 - 25 1.0 - 1.4 4.5 - 6.5 24 - 32	
A 30/AL 30		
A 40/AL 40		
A 50/AE 50	TA 75 DU...	
A 63/AE 63	29 - 42 45 - 63 36 - 52 60 - 80	
A 75/AE 75		
A 95/AE 95	TA 80 DU...	TA 110 DU...
A 110/AE 110	60 - 80	65 - 90 80 - 110
A 145/AF 145	TA 200 DU...	E 200 DU...
A 185/AF 185	130 - 175 150 - 200	60 - 200
A 210/AF 210	TA 450 DU...	E 320 DU...
A 260/AF 260	165 - 235 220 - 310	100 - 320
A 300/AF 300		
AF 400		E 500 DU...
AF 460		150 - 500
AF 580		E 800 DU...
AF 750		250 - 800
AF 1350		E 1250 DU...
AF 1650		375 - 1250

# A 9 ... A 110 3-Pole Contactors a.c. operated

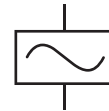

## Applications

Block type design mainly used for controlling 3-phase motors and generally for controlling power circuits up to 690 V a.c./1000 V a.c. or 220 V d.c./440 V d.c. The contactors can also be used for many other applications, such as isolation, capacitor switching, and lighting.

## Features

- a.c. operated control circuit with laminated magnet circuit
- wide range of accessories available

### A 9 ... A 40 1-stack contactors

- 3 main poles
- 1 built-in auxiliary contact
- front and side mounted add-on auxiliary contact blocks

### A 50 ... A 110 contactors

- 3 main poles
- front and side mounted add-on auxiliary contact blocks

### A 9 ... A 40 2-stack contactors

- 1st stack with 3 main poles and 1 built-in auxiliary contact
- 2nd stack with 4 built-in auxiliary contacts
- side mounted add-on auxiliary contact blocks

## Variants

- d.c. operated: AL 9...AL 40, AL 9Z...AL 16Z and AE 50...AE 110 contactors
- Electronic coil interface (a.c./d.c. operated): AF 50...AF110 contactors
- contactors for d.c. switching (GA..., GAE... types)



Location of surge suppressors

Location of side mounted accessories (on right or left hand side)

Quick fixing on mounting rail according to IEC 60715/EN 60715 standards:  
35 x 7.5 mm for A9 ... A 40 contactors  
35 x 15 mm for A 9 ... A 75 contactors  
75 x 25 mm for A 50 ... A 110 contactors

Holes for screw fixing (screws not supplied)

Terminals delivered in open position with captive screws

Screwdriver guidance for all terminals

Degree of protection (IP..) of terminals according to IEC 60947-1:

**A 9 ... A 40 contactors**  
IP20 for main and auxiliary terminals

**A 50 ... A 110 contactors**  
IP 10 for main terminals,  
IP 20 for auxiliary terminals

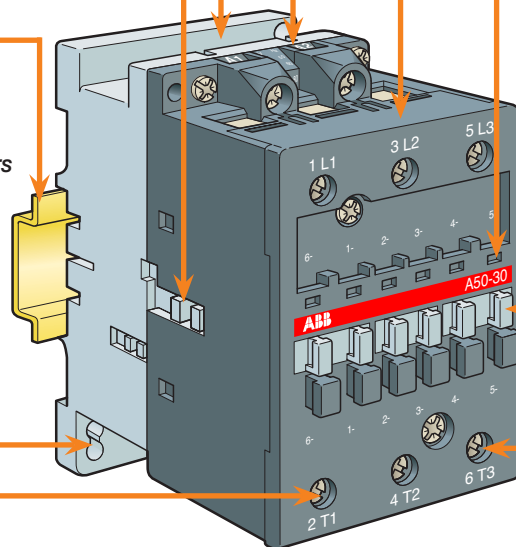

Clear marking of coil voltages and frequencies

Terminal marking according to IEC 60947-4-1, EN 50005, EN 50012 and NEMA standards

Location of function marker

Stops for attaching front mounted accessories

Terminal screws:

**A 9 ... A 16 contactors**  
M3.5 Pozidriv (+/-) No. 2 for all terminals

**A 26 contactors**  
M4 Pozidriv (+/-) No. 2 for main and auxiliary terminals,  
M3.5 Pozidriv (+/-) No. 2 for coil terminals

**A 30, A 40 contactors**  
M5 Pozidriv (+/-) No. 2 for main terminals,  
M3.5 Pozidriv (+/-) No. 2 for auxiliary and coil terminals

**A 50 ... A 75 contactors**  
M6 Pozidriv (+/-) No. 2 for main terminals,  
M3.5 Pozidriv (+/-) No. 2 for coil terminals

**A 95 ... A 110 contactors**  
M8 Hexagon socket (s = 4mm) for main terminals,  
M3.5 Pozidriv (+/-) No. 2 for coil terminals

# A 9 ... A 110 3-Pole Contactors



**HOW TO ORDER:**

<b>Number of Contacts</b>		<b>Part Number</b>
1st stack	2nd stack	state coil voltage code <span style="border: 1px solid black; padding: 2px;">  </span> <span style="border: 1px solid black; padding: 2px;">  </span>
		(see table below)

**Packing Quantity: 1 pc**

Contactor	IEC Rated Power 400 V AC-3	IEC Rated Current 0 ≤ 40° C AC-1	UL/CSA 3-Phase Motor Rating 480 V	UL/CSA General Use Rating 600 V	Auxiliary Contacts		Part Number	Weight
					1st Stack	2nd Stack		
	4 kW	25 A	5 hp	21 A	— 1	— —	A 9-30-01 <span style="border: 1px solid black; padding: 2px;">  </span> <span style="border: 1px solid black; padding: 2px;">  </span>	0.750 lb (0.340 kg)
	4 kW	25 A	5 hp	21 A	1 —	2 2	A 9-30-32 <span style="border: 1px solid black; padding: 2px;">  </span> <span style="border: 1px solid black; padding: 2px;">  </span>	0.882 lb (0.400 kg)
	5.5 kW	27 A	7.5 hp	25 A	— 1	— —	A 12-30-01 <span style="border: 1px solid black; padding: 2px;">  </span> <span style="border: 1px solid black; padding: 2px;">  </span>	0.750 lb (0.340 kg)
	5.5 kW	27 A	7.5 hp	25 A	1 —	2 2	A 12-30-32 <span style="border: 1px solid black; padding: 2px;">  </span> <span style="border: 1px solid black; padding: 2px;">  </span>	0.882 lb (0.400 kg)
	7.5 kW	30 A	10 hp	30 A	— 1	— —	A 16-30-01 <span style="border: 1px solid black; padding: 2px;">  </span> <span style="border: 1px solid black; padding: 2px;">  </span>	0.750 lb (0.340 kg)
	7.5 kW	30 A	10 hp	30 A	1 —	2 2	A 16-30-32 <span style="border: 1px solid black; padding: 2px;">  </span> <span style="border: 1px solid black; padding: 2px;">  </span>	0.882 lb (0.400 kg)
	11 kW	45 A	20 hp	40 A	— 1	— —	A 26-30-01 <span style="border: 1px solid black; padding: 2px;">  </span> <span style="border: 1px solid black; padding: 2px;">  </span>	1.323 lb (0.600 kg)
	11 kW	45 A	20 hp	40 A	1 —	2 2	A 26-30-32 <span style="border: 1px solid black; padding: 2px;">  </span> <span style="border: 1px solid black; padding: 2px;">  </span>	1.455 lb (0.660 kg)
	15 kW	55 A	25 hp	50 A	— 1	- -	A 30-30-01 <span style="border: 1px solid black; padding: 2px;">  </span> <span style="border: 1px solid black; padding: 2px;">  </span>	1.565 lb (0.710 kg)
	15 kW	55 A	25 hp	50 A	1 —	2 2	A 30-30-32 <span style="border: 1px solid black; padding: 2px;">  </span> <span style="border: 1px solid black; padding: 2px;">  </span>	1.698 lb (0.770 kg)
	18.5 kW	60 A	30 hp	60 A	— 1	— —	A 40-30-01 <span style="border: 1px solid black; padding: 2px;">  </span> <span style="border: 1px solid black; padding: 2px;">  </span>	1.565 lb (0.710 kg)
	18.5 kW	60 A	30 hp	60 A	1 —	2 2	A 40-30-32 <span style="border: 1px solid black; padding: 2px;">  </span> <span style="border: 1px solid black; padding: 2px;">  </span>	1.698 lb (0.770 kg)
	22 kW	100 A	40 hp	80 A	1 1	— —	A 50-30-11 <span style="border: 1px solid black; padding: 2px;">  </span> <span style="border: 1px solid black; padding: 2px;">  </span>	2.646 lb (1.200 kg)
	22 kW	100 A	40 hp	80 A	— —	2 2	A 50-30-22 <span style="border: 1px solid black; padding: 2px;">  </span> <span style="border: 1px solid black; padding: 2px;">  </span>	2.712 lb (1.230 kg)
	30 kW	115 A	60 hp	90 A	1 1	— —	A 63-30-11 <span style="border: 1px solid black; padding: 2px;">  </span> <span style="border: 1px solid black; padding: 2px;">  </span>	2.646 lb (1.200 kg)
	30 kW	115 A	60 hp	90 A	— —	2 2	A 63-30-22 <span style="border: 1px solid black; padding: 2px;">  </span> <span style="border: 1px solid black; padding: 2px;">  </span>	2.712 lb (1.230 kg)
	37 kW	125 A	60 hp	105 A	1 1	— —	A 75-30-11 <span style="border: 1px solid black; padding: 2px;">  </span> <span style="border: 1px solid black; padding: 2px;">  </span>	2.646 lb (1.200 kg)
	37 kW	125 A	60 hp	105 A	— —	2 2	A 75-30-22 <span style="border: 1px solid black; padding: 2px;">  </span> <span style="border: 1px solid black; padding: 2px;">  </span>	2.712 lb (1.230 kg)
	45 kW	145 A	60 hp	125 A	1 1	— —	A 95-30-11 <span style="border: 1px solid black; padding: 2px;">  </span> <span style="border: 1px solid black; padding: 2px;">  </span>	4.497 lb (2.040 kg)
	45 kW	145 A	60 hp	125 A	— —	2 2	A 95-30-22 <span style="border: 1px solid black; padding: 2px;">  </span> <span style="border: 1px solid black; padding: 2px;">  </span>	4.564 lb (2.070 kg)
	55 kW	160 A	75 hp	140 A	1 1	— —	A 110-30-11 <span style="border: 1px solid black; padding: 2px;">  </span> <span style="border: 1px solid black; padding: 2px;">  </span>	4.497 lb (2.040 kg)
	55 kW	160 A	75 hp	140 A	— —	2 2	A 110-30-22 <span style="border: 1px solid black; padding: 2px;">  </span> <span style="border: 1px solid black; padding: 2px;">  </span>	4.564 lb (2.070 kg)

## Coil Voltages and Codes

Voltage V - 50Hz	Voltage V - 60Hz	Code <span style="border: 1px solid black; padding: 2px;">  </span> <span style="border: 1px solid black; padding: 2px;">  </span>	Voltage V - 50Hz	Voltage V - 60Hz	Code <span style="border: 1px solid black; padding: 2px;">  </span> <span style="border: 1px solid black; padding: 2px;">  </span>
24	24	8 1	230 - 240	240 - 260	8 8
48	48	8 3	380 - 400	400 - 415	8 5
110	110 - 120	8 4	400 - 415	415 - 440	8 6
220 - 230	230 - 240	8 0			



## Accessory Fitting Details A 9 ... A 110 3-Pole Contactors

a.c. operated

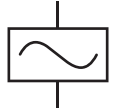

Many configurations of accessories are possible depending on whether these are front mounted or side mounted.

Contactor	Main Poles 	Auxiliary Contacts 	Front Mounted Accessories		Side Mounted Accessories		
			Auxiliary Contact 1-pole CA5-...	Auxiliary Contact 4-pole CA5-...	Auxiliary Contact 2-pol CA5-...		
A 9 ... A 26	3 0	1 0	1 to 4 x CA5-...	or	1 x CA5-... (4-pole) +	1 to 2 x CAL5-11	
A 9 ... A 26	3 0	0 1 (3)	1 to 4 x CA5-...	or	1 x CA5-... (4-pole) +	1 to 2 x CAL5-11	
A 9 ... A 16	3 0	2 2	n/a		n/a	1 to 2 x CAL5-11	
A 9 ... A 26	3 0	2 2	n/a		n/a	1 to 2 x CAL5-11	
A 30, A 40	3 0	1 0	1 to 5 x CA5-...	or	1 to 5 x CA5-... (4-pole) + 1 x 1-pole CA5-... (1)	1 to 2 x CAL5-11	
A 30, A 40	3 0	0 1 (3)	1 to 5 x CA5-...	or	1 to 5 x CA5-... (4-pole) + 1 x 1-pole CA5-... (1)	1 to 2 x CAL5-11	
A 30, A 40	3 0	0 2 (3)	1 x CA5-...		n/a	+	1 to 2 x CAL5-11
A 50 ... A 75	3 0	0 0	1 to 6 x CA5-...	or	1 x CA5-... (4-pole) + 2 x 1-pole CA5-... (1)	+	1 to 2 x CAL5-11
A 50 ... A 75	3 0	1 1	1 to 6 x CA5-...	or	1 x CA5-... (4-pole) + 2 x 1-pole CA5-... (1)	+	1 x CAL5-11
A 50 ... A 75	3 0	2 2	1 to 2 x CA5-...		n/a	+	1 to 2 x CAL5-11
A 95 ... A 110	3 0	0 0	1 to 6 x CA5-...	or	1 x CA5-... (4-pole) + 2 x 1-pole CA5-... (2)	+	1 to 2 x CAL18-11
A 95 ... A 110	3 0	1 1	1 to 6 x CA5-...	or	1 x CA5-... (4-pole) + 2 x 1-pole CA5-... (2)	+	1 x CAL18-11
A 95 ... A 110	3 0	2 2	1 to 2 x CA5-...		n/a	+	1 to 2 x CAL18-11

(1) Additional N.C. CA5-... auxiliary contacts are limited to 3.

(2) Additional N.C. CA5-... auxiliary contacts are limited to 5.

(3) 2 N.C. CA5-... auxiliary contacts maximum in mounting position 5.

### Contactor and Main Accessories

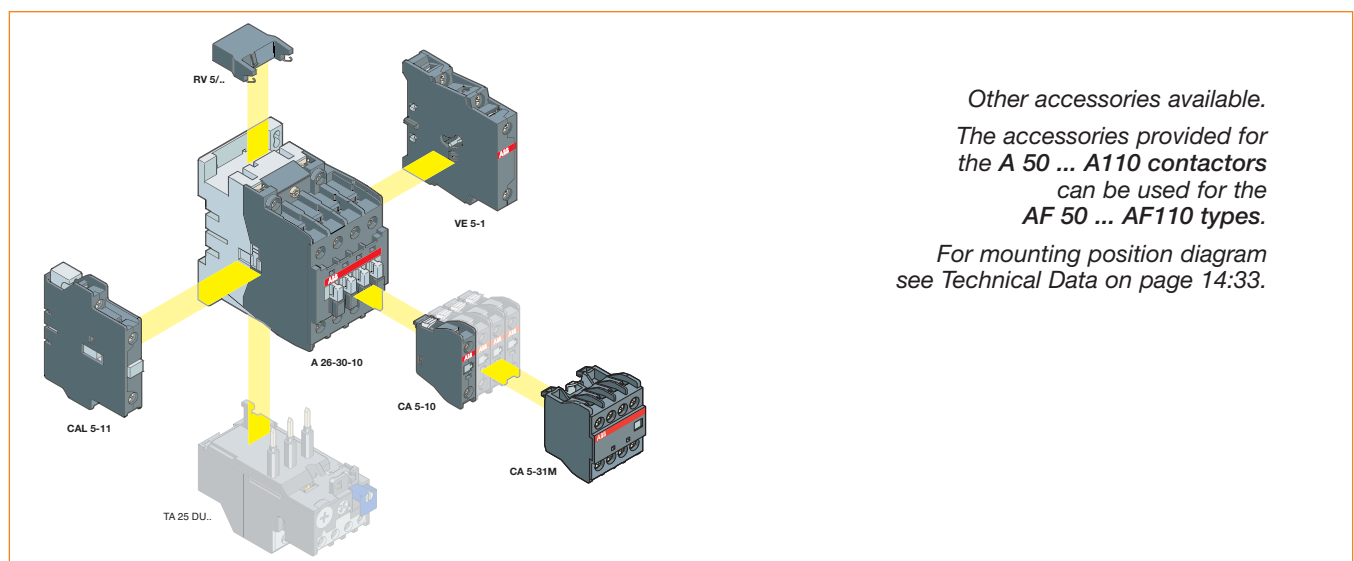

Other accessories available.  
The accessories provided for the A 50 ... A110 contactors can be used for the AF 50 ... AF110 types.  
For mounting position diagram see Technical Data on page 14:33.

# A 145 ... AF 1650 3-Pole Contactors

a.c. operated (A 145 ... A 300)  
a.c./d.c. operated (AF 400 ... AF 1650)

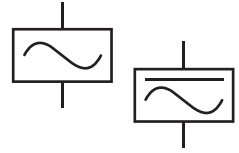

## Applications

Block type design that is mainly used for controlling 3-phase motors and generally for controlling power circuits up to 690 V a.c./1000 V a.c. or 220 V d.c./600 V d.c. The contactors can also be used for many other applications such as isolation, bypass, capacitor switching, lighting, etc.

## Features

- 3 main poles
- 1 N.O. and 1 N.C. auxiliary contact block fitted on left side
- maximum of 4 auxiliary contact blocks can be fitted on each contactor
- wide range of accessories available

## A 145 ... A 300 contactors

- a.c. operated control circuit with laminated magnet circuit

## AF 400 ... AF 1650 contactors

- a.c. operated, wide voltage range control circuit with electronic coil interface which accepts a wide control voltage range for a.c. 50/60 Hz supply or d.c. supply



## Variants

- electronic coil interface (a.c./d.c. operated) with wide voltage range: AF 145 ... AF 300 contactors

Main terminals  
(screws and nut insert holders are included)

Screw fixing, top and bottom  
(screws supplied)

Location of side mounted mechanical interlock  
(on right or left hand side)

CAL18-11 side mounted auxiliary contact block  
with easy access to the terminals

On-Off position indicator

Location of function marker

Terminal shrouds for protection can easily be fitted from the front

Quick release quarter turn screws for easy access to contact inspection

Terminal markings according to IEC 60947-4-1, EN 50005, EN 50012 and NEMA standards

Easy access to the coil terminals  
Clear marking of coil voltages and frequencies

Front access to the coil  
No need to remove power cables when changing coil

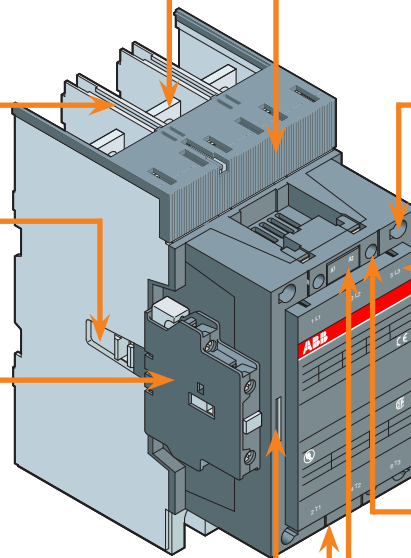

# A 145 ... AF 1650 3-Pole Contactors

a.c. operated  
a.c./d.c. operated

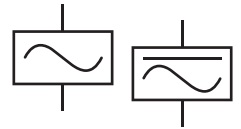

## HOW TO ORDER:

Number of Contacts  
1st stack 2nd stack









Part Number  
state coil voltage  
code

(see table below)

Packing Quantity: 1 pc

Notes: A 145 ... A 300 contactors - a.c. operated  
AF 400 ... AF 1650 contactors - a.c./d.c. operated

Contactor	IEC Rated Power 400 V AC-3	IEC Rated Current 0 ≤ 40° C AC-1	UL/CSA 3-Phase Motor Rating 480 V	UL/CSA General Use Rating 600 V	Auxiliary Contacts 	Part Number	Weight
	75 kW	250 A	100 hp	230 A	1 1	A 145-30-11 <input type="text"/> <input type="text"/> <input type="text"/> <input type="text"/>	0.772 lb (3.500 kg)
	90 kW	275 A	125 hp	250 A	1 1	A 185-30-11 <input type="text"/> <input type="text"/> <input type="text"/> <input type="text"/>	0.772 lb (3.500 kg)
	110 kW	350 A	150 hp	300 A	1 1	A 210-30-11 <input type="text"/> <input type="text"/> <input type="text"/> <input type="text"/>	13.448 lb (3.500 kg)
	140 kW	400 A	200 hp	350 A	1 1	A 260-30-11 <input type="text"/> <input type="text"/> <input type="text"/> <input type="text"/>	13.448 lb (3.500 kg)
	160 kW	500 A	250 hp	400 A	1 1	A 300-30-11 <input type="text"/> <input type="text"/> <input type="text"/> <input type="text"/>	13.448 lb (3.500 kg)
	200 kW	600 A	350 hp	550 A	1 1	AF 400-30-11 <input type="text"/> <input type="text"/> <input type="text"/> <input type="text"/>	26.455 lb (12.00 kg)
	250 kW	700 A	400 hp	650 A	1 1	AF 460-30-11 <input type="text"/> <input type="text"/> <input type="text"/> <input type="text"/>	26.455 lb (12.00 kg)
	315 kW	800 A	500 hp	750 A	1 1	AF 580-30-11 <input type="text"/> <input type="text"/> <input type="text"/> <input type="text"/>	33.069 lb (15.00 kg)
	400 kW	1050 A	600 hp	900 A	1 1	AF 750-30-11 <input type="text"/> <input type="text"/> <input type="text"/> <input type="text"/>	33.069 lb (15.00 kg)
	475 kW	1350 A	800 hp	1350 A	1 1	AF 1350-30-11 <input type="text"/> <input type="text"/> <input type="text"/> <input type="text"/>	74.957 lb (34.00 kg)
	560 kW	1650 A	900 hp	1650 A	1 1	AF 1650-30-11 <input type="text"/> <input type="text"/> <input type="text"/> <input type="text"/>	77.162 lb (35.00 kg)

## Coil Voltages and Codes A 145 ... A 300

Voltage V - 50Hz	Voltage V - 60Hz	Code <input type="text"/> <input type="text"/>
24	24	8 1
48	48	8 3
110	110 - 120	8 4
220 - 230	230 - 240	8 0
230 - 240	240 - 260	8 8
380 - 400	400 - 415	8 5
400 - 415	415 - 440	8 6

## Coil Voltages and Codes AF 400 ... AF 750

Voltage V - 50/60Hz	Voltage V d.c.	Code <input type="text"/> <input type="text"/>
—	24 - 60	6 8(1)
48 - 130	48 - 130	6 9
100 - 250	100 - 250	7 0
250 - 500	250 - 500	7 1

(1) The connection polarities indicated close to the coil terminals must be respected: A1 for the positive pole and A2 for the negative pole.

## Coil Voltages and Codes AF 1350 ... AF 1650

Voltage V - 50/60Hz	Voltage V d.c.	Code <input type="text"/> <input type="text"/>
100 - 250	100 - 250	7 0

# Accessory Fitting Details

## A 145 ... AF 1650 3-pole Contactors

a.c. operated  
a.c./d.c. operated

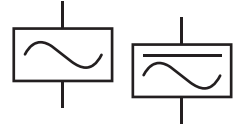

### Contactors + Auxiliary Contact Blocks

Contactor	Main Poles 	Auxiliary Contacts 	Side Mounted Accessories		Mechanical Interlock Units	Mounting and Positioning (see legend below)
			Add-on Auxiliary Contact 1-pole CAL18-11	Add-on Auxiliary Contact 4-pole CAL18-11B		
A 145 ... A 300 AF 145 ... AF 1650	3 0	1 1	1 x CA18-11	+ 2 x CAL18-11B	—	
A 145 ... A 300 AF 145 ... AF 1650	3 0	2 2	1 x CA18-11	+ 2 x CAL18-11B	—	

### Contactors with Mechanical Interlocking + Auxiliary Contact Blocks

Contactor	Main Poles 	Auxiliary Contacts 	Side Mounted Accessories		Mechanical Interlock Units	Mounting and Positioning (see legend below)
			Add-on Auxiliary Contact 1-pole CAL18-11	Add-on Auxiliary Contact 4-pole CAL18-11B		
A 145 ... A 185 AF 145 ... AF 185	3 0	1 1	2 x CA18-11 (1)	+ 3 x CAL18-11B (1) +	VM ... H (2)	
A 145 ... A 185 AF 145 ... AF 185	3 0	2 2	—	3 x CAL18-11B (1) +	VM ... H (2)	
A 210 ... A 300 AF 210 ... AF 1650	3 0	1 1	2 x CA18-11 (1)	+ 4 x CAL18-11B (1) +	VM ... H (2)	
A 210 ... A 300 AF 210 ... AF 1650	3 0	2 2	—	4 x CAL18-11B (1) +	VM ... H (2)	

(1) Total number of auxiliary contact blocks for the two contactors.

(2) Interlock type, according to the contactor ratings.

Mounting and

Positioning Legend: Factory mounted auxiliary contacts Add-on CAL18-11 auxiliary contacts Add-on CAL18-11B auxiliary contacts

### Contactor and Main Accessories

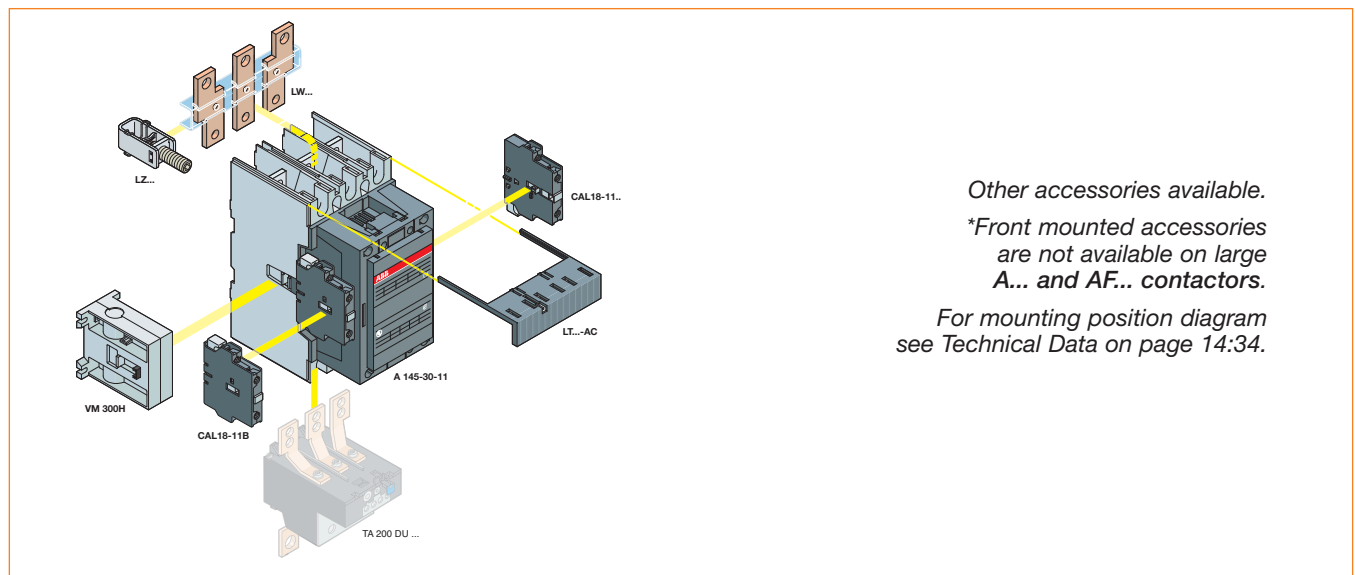

# A 9 ... AE 110, AL...Z... 3-Pole Contactors d.c. operated

## Applications

Block type design mainly used for controlling 3-phase motors and more generally for controlling power circuits up to 690 V a.c. (1000 V a.c. for AE... contactors) or 220 V d.c./440 V d.c.

## Features

- AL... contactors are fitted with low consumption d.c. coils (pull-in and holding):  
AL 9 ... AL 16: 3W  
AL 26 ... AL 40: 3.5 W  
AL 9 Z ... AL 16Z: 2.4 W (with very low consumption)
- d.c. operated control circuit (The polarity on the coil terminals (A1+ and A2-) must be respected for AL... and AL..Z contactors.)
- wide range of accessories available

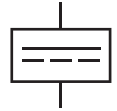

## AL 9 ... AL 40 1-stack contactors

- 3 main poles
- 1 built-in auxiliary contact
- front or side mounted add-on auxiliary contact blocks

## AE 50 ... AE 110 contactors

- 3 main poles
- front or side mounted add-on auxiliary contact blocks
- Larger d.c. operated contactors: use AF 145 ... AF 1650 types

## AL 9 ... AL 40 2-stack contactors

- 1st stack with 3 main poles
- 2nd stack with 4 built-in auxiliary contacts
- mechanically linked built-in auxiliary contact elements

## Variants

- Electronic coil interface (a.c./d.c. operated): AF 50...AF110 contactors
- AL 9... AL 26 and AE 45... AE 75 contactors: 4-pole (with 4 N.O. or 2 N.O. + 2 N.C. main poles)

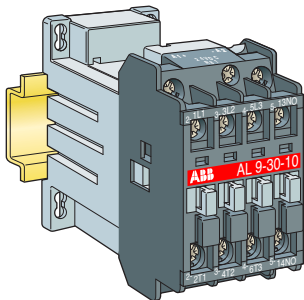

**AL 9 ... AL 40 contactors**  
General design is identical to that of A 9 ... A 40 contactors.  
Only the depth is increased.

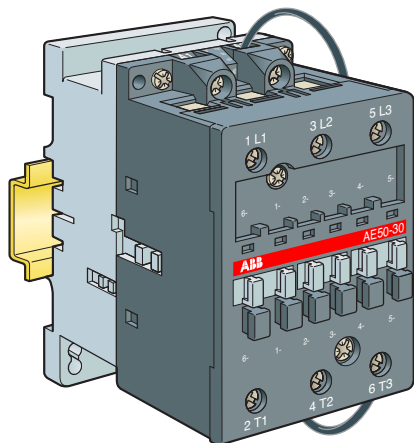

**AE 50 ... AE 110 contactors**  
Add-on lagging contact (factory mounted) for insertion of the "holding" winding.

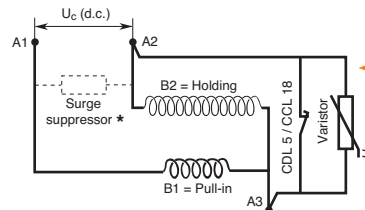

**AE 50 ... AE 110 contactors**  
N.C. lagging auxiliary contact block with built-in varistor  
CDL 5-01 type fitted on AE 50 ... AE 75  
CCL 18-01 type fitted on AE 95 ... AE 110  
Extra RV5 or (RT5) surge suppressor can be added on to the "pull-in" winding, if required. (Please order separately.)

# AL 9 ... AL 110 and AL..Z... 3-Pole Contactors

d.c. operated

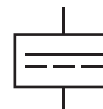

## AL 9 ... AE 110 Contactors

Contactor	IEC Rated Power 400 V AC-3	IEC Rated Current 0 ≤ 40° C AC-1	UL/CSA 3-Phase Motor Rating 480 V	UL/CSA General Use Rating 600 V	Auxiliary Contacts		Part Number	Weight
					1st Stack	2nd Stack		
	4 kW	25 A	5 hp	21 A	— 1	— —	AL 9-30-01 [ ] [ ] [ ] [ ]	1.146 lb (0.520 kg)
	4 kW	25 A	5 hp	21 A	— —	2 2	AL 9-30-22 [ ] [ ] [ ] [ ]	1.279 lb (0.580 kg)
	5.5 kW	27 A	7.5 hp	25 A	— 1	— —	AL 12-30-01 [ ] [ ] [ ] [ ]	1.146 lb (0.520 kg)
	5.5 kW	27 A	7.5 hp	25 A	— —	2 2	AL 12-30-22 [ ] [ ] [ ] [ ]	1.279 lb (0.580 kg)
	7.5 kW	30 A	10 hp	30 A	— 1	— —	AL 16-30-01 [ ] [ ] [ ] [ ]	1.146 lb (0.520 kg)
	7.5 kW	30 A	10 hp	30 A	— —	2 2	AL 16-30-22 [ ] [ ] [ ] [ ]	1.279 lb (0.580 kg)
	11 kW	45 A	20 hp	40 A	— 1	— —	AL 26-30-01 [ ] [ ] [ ] [ ]	1.323 lb (0.600 kg)
	11 kW	45 A	20 hp	40 A	— —	2 2	AL 26-30-22 [ ] [ ] [ ] [ ]	1.455 lb (0.660 kg)
	15 kW	55 A	25 hp	50 A	— 1	- -	AL 30-30-01 [ ] [ ] [ ] [ ]	1.874 lb (0.850 kg)
	15 kW	55 A	25 hp	50 A	— —	2 2	AL 30-30-22 [ ] [ ] [ ] [ ]	2.006 lb (0.910 kg)
	18.5 kW	60 A	30 hp	60 A	— 1	— —	AL 40-30-01 [ ] [ ] [ ] [ ]	1.874 lb (0.850 kg)
	18.5 kW	60 A	30 hp	60 A	— —	2 2	AL 40-30-22 [ ] [ ] [ ] [ ]	2.006 lb (0.910 kg)
	22 kW	100 A	40 hp	80 A	1 1	— —	AE 50-30-11 [ ] [ ] [ ] [ ]	2.734 lb (1.240 kg)
	30 kW	115 A	60 hp	90 A	1 1	— —	AE 63-30-11 [ ] [ ] [ ] [ ]	2.734 lb (1.240 kg)
	37 kW	125 A	60 hp	105 A	1 1	— —	AE 75-30-11 [ ] [ ] [ ] [ ]	2.734 lb (1.240 kg)
	45 kW	145 A	60 hp	125 A	1 1	— —	AE 95-30-11 [ ] [ ] [ ] [ ]	4.564 lb (2.070 kg)
	55 kW	160 A	75 hp	140 A	1 1	— —	AE 110-30-11 [ ] [ ] [ ] [ ]	4.564 lb (2.070 kg)
	4 kW	25 A	5 hp	21 A	— 1	— —	AL 9Z-30-01 [ ] [ ] [ ] [ ]	1.146 lb (0.520 kg)
	5.5 kW	27 A	7.5 hp	25 A	— —	2 2	AL 12Z-30-01 [ ] [ ] [ ] [ ]	1.146 lb (0.520 kg)
	7.5 kW	30 A	10 hp	30 A	— 1	— —	AL 16Z-30-01 [ ] [ ] [ ] [ ]	1.146 lb (0.520 kg)

## AL 9Z ... AL 16Z Contactors

	4 kW	25 A	5 hp	21 A	— 1	— —	AL 9Z-30-01 [ ] [ ] [ ] [ ]	1.146 lb (0.520 kg)
	5.5 kW	27 A	7.5 hp	25 A	— —	2 2	AL 12Z-30-01 [ ] [ ] [ ] [ ]	1.146 lb (0.520 kg)
	7.5 kW	30 A	10 hp	30 A	— 1	— —	AL 16Z-30-01 [ ] [ ] [ ] [ ]	1.146 lb (0.520 kg)

## Coil Voltages and Codes

Voltage V d.c.	AL ... AE Code [ ] [ ]	AZ... Code [ ] [ ]	Voltage V d.c.	AL ... AE Code [ ] [ ]	AZ... Code [ ] [ ]	Voltage V d.c.	AL ... AE Code [ ] [ ]	AZ... Code [ ] [ ]
12	8 0	— —	50	2 1	— —	125	8 7	— —
24	8 1	1 5	60	8 4	— —	220	8 8	— —
42	8 2	— —	75	8 5	— —	240	8 9	— —
48	8 3	2 0	110	8 4	— —	250	3 8	— —

## Accessory Fitting Details AL 9 ... AE 110 and AL..Z 3-Pole Contactors

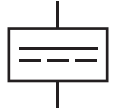

Many configurations of accessories are possible depending on whether these are front mounted or side mounted.

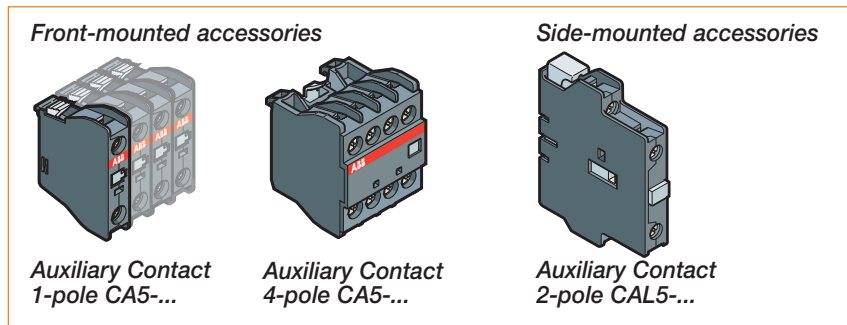

### AL 9 ... AL 40 and AL..Z 110 Contactors

Contactor	Main Poles 	Auxiliary Contacts 	Front Mounted Accessories		Side Mounted Accessories
			Auxiliary Contact 1-pole CA5-...	Auxiliary Contact 4-pole CA5-...	Auxiliary Contact 2-pole CAL5-...
AL 9 ... AL 16	3 0	1 0	1 to 4 x CA5-... (1)	or 1 x CA5-... (4-pole) (1)	+ 1 x CAL5-11
AL 9 ... AL 16	3 0	0 1	1 to 4 x CA5-... (1)	or 1 x CA5-... (4-pole) (1)	+ 1 x CAL5-11
AL 26	3 0	1 0	1 to 4 x CA5-... (2)	or 1 x CA5-... (4-pole) (2)	1 x CAL5-11
AL 26	3 0	0 1	1 to 4 x CA5-... (2)	or 1 x CA5-... (4-pole) (2)	1 x CAL5-11
AL 30, AL 40	3 0	1 0	1 to 5 x CA5-... (2)	or 1 x CA5-... (4-pole) (2) + 1 x 1-pole CA5-...	1 x CAL5-11
AL 30, AL 40	3 0	0 1	1 to 5 x CA5-... (2)	or 1 x CA5-... (4-pole) (2) + 1 x 1-pole CA5-...	1 x CAL5-11
AL 9Z ... AL 16Z (3)	3 0	1 0	1 to 2 x CA5-... (1)		n/a
AL 9Z ... AL 16Z (3)	3 0	0 1	1 to 2 x CA5-... (1)	or n/a	n/a

(1) 2 N.C. auxiliary contacts maximum in all mounting positions except 5. In position 5 no N.C. auxiliary contact allowed.  
 (2) 2 N.C. auxiliary contacts maximum in mounting position 5.  
 (3) Not allowed in mounting position 1 +/- 30°.

### AE 50 ... AE 110 Contactors

Contactor	Main Poles 	Auxiliary Contacts 	Front Mounted Accessories		Side Mounted Accessories
			Auxiliary Contact 1-pole CA5-...	Auxiliary Contact 4-pole CA5-...	Auxiliary Contact 2-pole CAL5-...
AE 50 ... AE 75	3 0	0 0	1 to 6 x CA5-...	or 1 x CA5-... (4-pole) + 2 x 1-pole CA5-... (1)	+ 1 x CAL5-11
AE 50 ... AE 75	3 0	1 1	1 to 6 x CA5-...	or 1 x CA5-... (4-pole) + 2 x 1-pole CA5-... (1)	+ n/a
AE 95, AE 110	3 0	0 0	1 to 6 x CA5-...	or 1 x CA5-... (4-pole) + 2 x 1-pole CA5-... (1)	1 x CAL18-11
AE 95, AE 110	3 0	1 1	1 to 6 x CA5-...	or 1 x CA5-... (4-pole) + 2 x 1-pole CA5-... (1)	n/a

(1) The total number of N.O. or N.C. CA5- auxiliary contacts is limited to 5.

# AF 50 ... AF 110 3-Pole Contactors

## Electronic Coil Interface

### a.c./d.c. operated

### Wide Voltage Range



#### Applications

Block type design mainly used for controlling 3-phase motors and generally for controlling power circuits up to 690 V a.c. and 220 V d.c.

The contactors can also be used for many other applications such as bypass, capacitor switching, lighting and d.c. power circuits.

The AF... contactors are fitted with an electronic coil interface which accepts a wide control voltage range, on a.c. 50/60 Hz or d.c. supplies. The same contactor can accept various supply voltages according to the different countries where the electrical equipment will be installed, or some fluctuation in the control voltage due to the local supply or network.

The AF... contactors are also fully suitable for operation in a.c. or d.c. control circuit liable to voltage interruptions or voltage dip risks.

#### Features

- 3 main poles
- front and side mounted add-on auxiliary contact blocks
- wide voltage range, e.g. 100 ... 250 V a.c. and d.c.
- can manage large voltage variations
- reduced power consumption
- very distinct closing and opening
- noise free
- can withstand voltage interruptions or voltage dips in the control supply ( $\leq 20$  ms)
- wide range of accessories available (accessories provided for A 50 ... A 110 contactors can be used for the AF 50 ... AF 110 types)



#### Electronic Control

The contactors are fitted with an electronic interface that very precisely controls the voltage to the coil. The electronic control circuit always works using d.c. current through the coil and in a.c. operation the current is rectified before being applied to the coil.

To achieve the levels of the currents required for making and holding respectively, the voltage is pulsed across the coil with the aid of a transistor. The pulsing also implies that the current in the coil can be optimally regulated all the time relatively independently of the voltage level. The function is controlled by a specific integrated circuit developed by ABB.

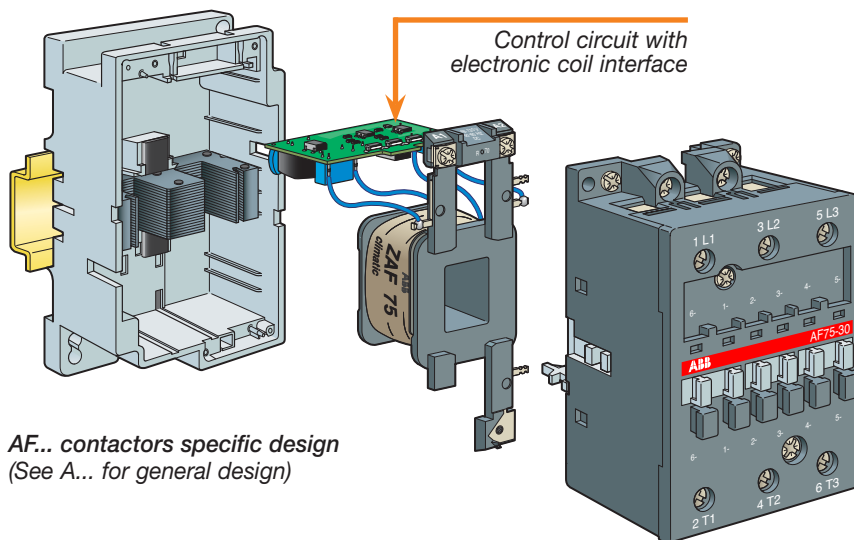

AF... contactors specific design  
(See A... for general design)

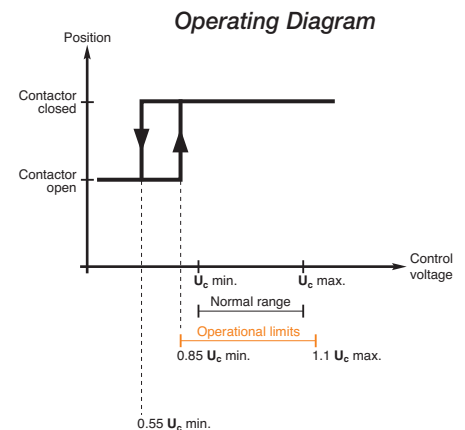



# AF 50 ... AF 110 3-Pole Contactors Electronic Coil Interface

a.c./d.c. operated  
wide voltage range

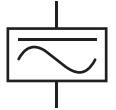

## HOW TO ORDER:

Number of Contacts

1st stack    2nd stack





Part Number

state coil voltage  
code

(see table below)

Packing Quantity: 1 pc

Contactor	IEC Rated Power 400 V AC-3	IEC Rated Current 0 ≤ 40° C AC-1	UL/CSA 3-Phase Motor Rating 480 V	UL/CSA General Use Rating 600 V	Auxiliary 1st Stack	Contacts 2nd Stack	Part Number	Weight
	22 kW	100 A	40 hp	80 A	1 1	--	AF 50-30-11 <input type="text"/> <input type="text"/> <input type="text"/> <input type="text"/>	2.690 lb (1.220 kg)
	30 kW	115 A	60 hp	90 A	1 1	--	AF 63-30-11 <input type="text"/> <input type="text"/> <input type="text"/> <input type="text"/>	2.690 lb (1.220 kg)
	37 kW	125 A	60 hp	105 A	1 1	--	AF 75-30-11 <input type="text"/> <input type="text"/> <input type="text"/> <input type="text"/>	2.690 lb (1.220 kg)
	45 kW	145 A	60 hp	125 A	1 1	--	AF 95-30-11 <input type="text"/> <input type="text"/> <input type="text"/> <input type="text"/>	4.564 lb (2.070 kg)
	55 kW	160 A	75 hp	140 A	1 1	--	AF 110-30-11 <input type="text"/> <input type="text"/> <input type="text"/> <input type="text"/>	4.564 lb (2.070 kg)

## Coil Voltages and Codes

Voltage V - 50/60Hz	Voltage V d.c.	Code <input type="text"/> <input type="text"/>
—	20 - 60	7 2(1)
48 - 130	48 - 130	6 9
100 - 250	100 - 250	7 0

(1) The connection polarities indicated close to the coil terminals must be respected: A1 for the positive pole and A2 for the negative pole.

## Electromagnetic Compatibility

AF... contactors comply with IEC 60947-1, 60947-4-1 and EN 60947-1, 60947-4-1

**Note:** This product has been designed for environment A. Use of this product in environment B may cause unwanted electromagnetic disturbances in which case the user may be required to take adequate mitigation measures.

**Environment A:** “Mainly relates to low-voltage non public or industrial networks/locations/installations (see EN 50082-2 article 4) including highly disturbing sources.”

**Environment B:** “Mainly relates to low-voltage public networks (see EN 50082-1 article 5) such as residential, commercial and light industrial locations/installations. Highly disturbing sources such as arc welders are not covered by this environment.”

# AF 145 ... AF 1650 3-Pole Contactors

## Electronic Coil Interface

### a.c./d.c. operated

### Wide Voltage Range



#### Applications

Block type design mainly used for controlling 3-phase motors and generally for controlling power circuits up to 690 V a.c. / 1000 V a.c. or 220 V d.c. / 600 V d.c. The contactors can also be used for many other applications such as bypass, capacitor switching, lighting and d.c. power circuits.

The AF... contactors are fitted with an electronic coil interface which accepts a wide control voltage range, on a.c. 50/60 Hz or d.c. supplies. The same contactor can accept various supply voltages according to the different countries where the electrical equipment will be installed, or some fluctuation in the control voltage due to the local supply or network.

The AF... contactors are also fully suitable for operation in a.c. or d.c. control circuit liable to voltage interruptions or voltage dip risks.



#### Electronic Control

The contactors are fitted with an electronic interface that very precisely controls the voltage to the coil. The electronic control circuit always works using d.c. current through the coil and in a.c. operation the current is rectified before being applied to the coil.

To achieve the levels of the currents required for making and holding respectively, the voltage is pulsed across the coil with the aid of a transistor. The pulsing also implies that the current in the coil can be optimally regulated all the time relatively independently of the voltage level. The function is controlled by a specific integrated circuit developed by ABB.

#### Features

- 3 main poles
- 1 N.O. and 1 N.C. auxiliary contact block fitted on left side
- maximum of 4 auxiliary contact blocks can be fitted on each contactor
- wide voltage range, e.g. 100 ... 250 V a.c. and d.c.
- can manage large voltage variations
- reduced power consumption
- very distinct closing and opening
- noise free
- can withstand voltage interruptions or voltage dips in the control supply ( $\leq 20$  ms)
- wide range of accessories available (accessories provided for A 50 ... A 110 contactors can be used for the AF 50 ... AF 110 types)
- large sizes AF 400 ... AF 1650 are equipped with low voltage inputs for control (for example by a PLC)

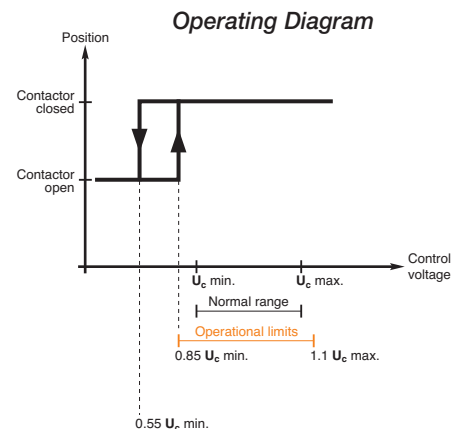
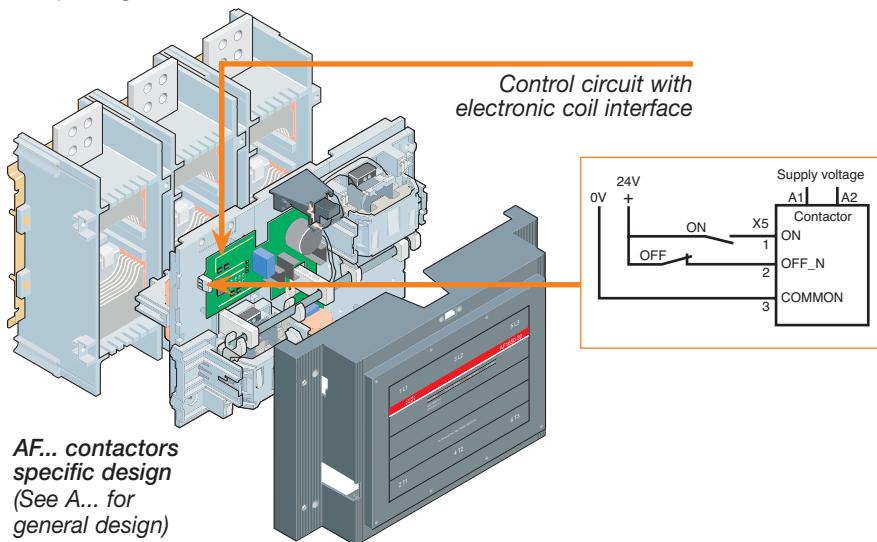

# AF 145 ... AF 1650 3-Pole Contactors

## Electronic Coil Interface

a.c./d.c. operated  
wide voltage range

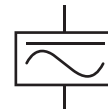

Contactor	IEC Rated Power 400 V AC-3	IEC Rated Current 0 ≤ 40° C AC-1	UL/CSA 3-Phase Motor Rating 480 V	UL/CSA General Use Rating 600 V	Auxiliary Contacts 	Part Number	Weight
	75 kW	250 A	100 hp	230 A	1 1	AF 145-30-11	7.937 lb (3.600 kg)
	75 kW	250 A	100 hp	230 A	2 2	AF 145-30-22	7.937 lb (3.600 kg)
	90 kW	275 A	125 hp	250 A	1 1	AF 185-30-11	7.937 lb (3.600 kg)
	90 kW	275 A	125 hp	250 A	2 2	AF 185-30-22	7.937 lb (3.600 kg)
	110 kW	350 A	150 hp	300 A	1 1	AF 210-30-11	13.669 lb (6.200 kg)
	110 kW	350 A	150 hp	300 A	2 2	AF 210-30-22	13.669 lb (6.200 kg)
	140 kW	400 A	200 hp	350 A	1 1	AF 260-30-11	13.669 lb (6.200 kg)
	140 kW	400 A	200 hp	350 A	2 2	AF 260-30-22	13.669 lb (6.200 kg)
	160 kW	500 A	250 hp	400 A	1 1	AF 300-30-11	13.669 lb (6.200 kg)
	160 kW	500 A	250 hp	400 A	2 2	AF 300-30-22	13.669 lb (6.200 kg)
	200 kW	600 A	350 hp	550 A	1 1	AF 400-30-11	26.455 lb (12.00 kg)
	200 kW	600 A	350 hp	550 A	2 2	AF 400-30-22	26.455 lb (12.00 kg)
	250 kW	700 A	400 hp	650 A	1 1	AF 460-30-11	26.455 lb (12.00 kg)
	250 kW	700 A	400 hp	650 A	2 2	AF 460-30-22	26.455 lb (12.00 kg)
	315 kW	800 A	500 hp	750 A	1 1	AF 580-30-11	33.069 lb (15.00 kg)
	315 kW	800 A	500 hp	750 A	2 2	AF 580-30-22	33.069 lb (15.00 kg)
	400 kW	1050 A	600 hp	900 A	1 1	AF 750-30-11	33.069 lb (15.00 kg)
	400 kW	1050 A	600 hp	900 A	2 2	AF 750-30-22	33.069 lb (15.00 kg)
	475 kW	1350 A	800 hp	1350 A	1 1	AF 1350-30-11	74.957 lb (34.00 kg)
	475 kW	1350 A	800 hp	1350 A	2 2	AF 1350-30-22	74.957 lb (34.00 kg)
	560 kW	1650 A	900 hp	1650 A	1 1	AF 1650-30-11	77.162 lb (35.00 kg)
	560 kW	1650 A	900 hp	1650 A	2 2	AF 1650-30-22	77.162 lb (35.00 kg)

### Coil Voltages and Codes AF 145 ... AF 300

Voltage V - 50/60Hz	Voltage V d.c.	Code 
—	20 - 60	7 2(1)
48 - 130	48 - 130	6 9
100 - 250	100 - 250	7 0

### Coil Voltages and Codes AF 1350, AF 1650

Voltage V - 50/60Hz	Voltage V d.c.	Code 
100 - 250	100 - 250	7 0

### Coil Voltages and Codes AF 400 ... AF 750

Voltage V - 50/60Hz	Voltage V d.c.	Code 
—	24 - 60	6 8(1)
48 - 130	48 - 130	6 9
100 - 250	100 - 250	7 0
250 - 500	250 - 500	7 1

(1) The connection polarities indicated close to the coil terminals must be respected: A1 for the positive pole and A2 for the negative pole.

### Electromagnetic Compatibility

Note: See page 14:17 for details on Environment A and B.

# GA 75, GAE 75 Contactors d.c. switching

## Applications

Block type design used for d.c. circuit switching. Arc suppression is more difficult in d.c. than in a.c. To choose a contactor, it is necessary to know the current and voltage to be broken as well as the L/R time constant of the power circuit to be controlled.

Typical time contact values:

- DC-1: non inductive loads such as resistance furnaces..... L/R  $\approx$  1.0 ms
- DC-3: shunt motors..... L/R  $\approx$  2.0 ms
- DC-5: series motors..... L/R  $\approx$  7.5 ms

## Features

- main poles - these contactors are fitted with arc chutes with permanent magnets specially designed for d.c. breaking. The 3 contactor paths are arranged in series via two supplied and fitted insulated connections (25 mm<sup>2</sup>). They are "single-pole" devices for which the connection polarities indicated next to the connection terminals must be respected. Furthermore, they are marked **1L1** for the positive terminal and **2T1** for the negative terminal.
- auxiliary contact - 1 CAL5-11 side mounted add-on auxiliary contact block (GA 75-10-11 and GAE 75-10-11 types)
- control circuit - a.c. operated (GA 75) d.c. operated (GAE 75)
- wide range of accessories available



Note: The addition of a resistor in parallel with an inductive winding makes arc suppression easier.

## Specific Technical Data

- rated insulation voltage  
 $U_1 = 100$  V d.c. according to IEC 60947-4-1 and EN 60947-4-7
- maximum switching frequencies  
300 operating cycles/h
- maximum rated operational current  $I_e$  according to IEC

<b>DC-1</b> ( $0 \leq 55^\circ$ C)	
$220$ V < $U_e \leq 440$ V	100 A
$440$ V < $U_e \leq 600$ V	75 A

<b>DC-3</b>	
$220$ V < $U_e \leq 440$ V	85 A

<b>DC-5</b>	
$110$ V < $U_e \leq 220$ V	85 A
$220$ V < $U_e \leq 440$ V	35 A

- maximum rated operational current  $I_e$  according to UL/CSA

<b>General use</b>	
$U_e \leq 440$ V	100 A
$U_e \leq 600$ V	75 A
$U_e \leq 1000$ V	35 A

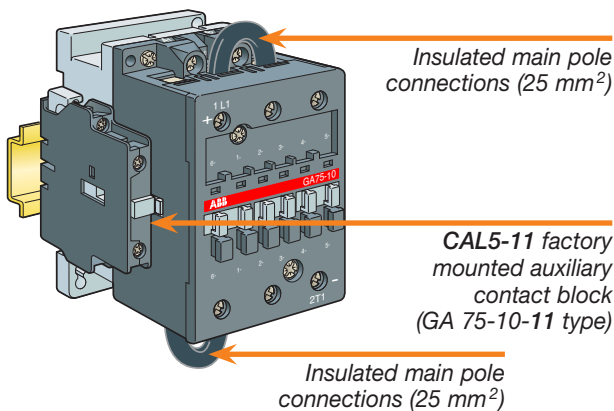

GA 75 and GAE 75 contactors specific design (See A 9 ... A 110 for general design)

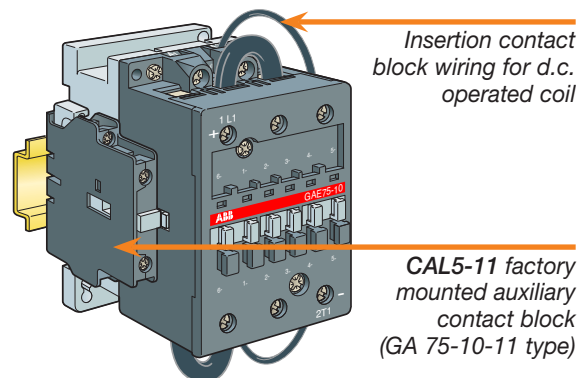

# GA 75, GAE 75 Contactors

d.c. switching

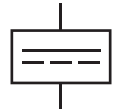

Contactor	IEC Rated Operational Current			Auxiliary Contacts 	Part Number	Weight
	DC-1 440 V 0 ≤ 55° C	DC-3 440 V	DC-5 440 V			
	100 A	85 A	85 A	1 1	GA 75-10-11	2.778 lb (1.260 kg)
	100 A	85 A	85 A	1 1	GAE 75-10-11	2.866 lb (1.300 kg)

## Coil Voltages and Codes GA 75

Voltage V - 50Hz	Voltage V - 60Hz	Code 
24	24	8 1
48	48	8 3
110	110 - 120	8 4
220 - 230	230 - 240	8 0
230 - 240	240 - 260	8 8
380 - 400	400 - 415	8 5
400 - 415	415 - 440	8 6

## Coil Voltages and Codes GAE 75

Voltage V d.c.	Code 
12	8 0
24	8 1
42	8 2
48	8 3
50	2 1
60	8 4
75	8 5
110	8 6
125	8 7
220	8 8
240	8 9
250	3 8

## Connection Diagrams

In d.c. circuits, the source to earth (or frame) connection mode is an important element. Three modes are mainly used.

- A - insulated source, i.e. unearthed (or not connected to the frame)
- B - source earthed via its central point
- C - source earthed via one of its outer poles

Modes A and B do not impose any constraints with regard to the distribution of the contactor poles between the two source/load connecting branches. Mode C requirements are therefore suitable for modes A and B.

For mode C, all the poles necessary for breaking must be installed in series between the load and the unearthed (also not connected to the frame) source polarity.

These provisions relate to power circuit switching, the SCPD (Short-Circuit Protection Device) must comply with protection rules.

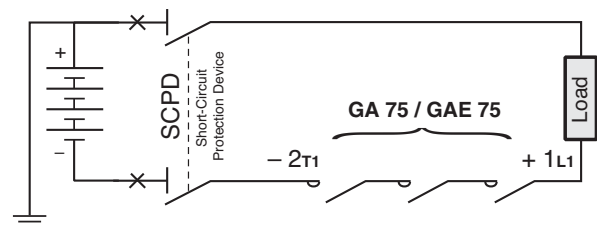
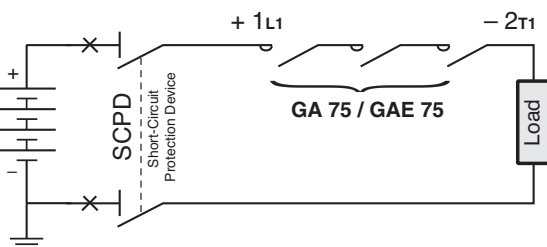

# Contactor Selection

## d.c. circuit switching

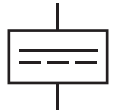

The arc switching on d.c. is more difficult than on a.c.

- For selecting a contactor it is essential to determine the **current**, the **voltage** and the **L/R time constant of the controlled load**.
- For information, typical time constant values are quoted hereafter: non inductive loads such as resistance furnaces ( $L/R \approx 2$  ms) or series motors ( $L/R \approx 7.5$  ms).

- The addition of a resistor in parallel with an inductive winding helps in the elimination of the arcs.
- All the poles required for breaking must be connected in series between the load and the source polarity not linked to earth (or chassis).

a.c. operated contactors		A 9	A 12	A 16	A 26	A 30	A 40	A 45	A 50	A 63	A 75	GA 75	
a.c./d.c. operated (electronic coil interface)		—	—	—	—	—	—	AF 45	AF 50	AF 63	AF 75	—	
d.c. operated contactors		AL 9	AL 12	AL 16	AL 26	AL 30	AL 40	AE 45	AE 50	AE 63	AE 75	GAE 75	
Utilization Category DC-1, L/R ≤ 1 ms		≤ 72 V	25 A	27 A	30 A	45 A	55 A	60 A	70 A	100 A	110 A	120 A	120 A
		110 V	10 A	15 A	20 A	—	—	—	—	—	—	—	120 A
		220 V	—	—	—	—	—	—	—	—	—	—	120 A
		440 V	—	—	—	—	—	—	—	—	—	—	100 A
		600 V	—	—	—	—	—	—	—	—	—	—	75 A
		≤ 72 V	25 A	27 A	30 A	45 A	55 A	60 A	70 A	100 A	110 A	120 A	—
		110 V	25 A	27 A	30 A	45 A	55 A	60 A	70 A	100 A	110 A	120 A	—
		220 V	10 A	15 A	—	—	—	—	—	—	—	—	—
		440 V	—	—	—	—	—	—	—	—	—	—	—
		600 V	—	—	—	—	—	—	—	—	—	—	—
		≤ 72 V	25 A	27 A	30 A	45 A	55 A	60 A	70 A	100 A	110 A	120 A	—
		110 V	25 A	27 A	30 A	45 A	55 A	60 A	70 A	100 A	110 A	120 A	—
220 V		25 A	27 A	30 A	45 A	55 A	60 A	70 A	100 A	110 A	120 A	—	
440 V		10 A	15 A	20 A	—	—	—	—	—	—	—	—	
600 V		—	—	—	—	—	—	—	—	—	—	—	
Utilization Category DC-3, L/R ≤ 2 ms		≤ 72 V	25 A	27 A	30 A	45 A	55 A	60 A	70 A	100 A	110 A	120 A	120 A
		110 V	6 A	7 A	8 A	—	—	—	—	—	—	—	120 A
		220 V	—	—	—	—	—	—	—	—	—	—	100 A
		440 V	—	—	—	—	—	—	—	—	—	—	85 A
		600 V	—	—	—	—	—	—	—	—	—	—	—
		≤ 72 V	25 A	27 A	30 A	45 A	55 A	60 A	70 A	100 A	110 A	120 A	—
		110 V	25 A	27 A	30 A	45 A	55 A	60 A	70 A	100 A	110 A	120 A	—
		220 V	6 A	7 A	8 A	—	—	—	—	—	—	—	—
		440 V	—	—	—	—	—	—	—	—	—	—	—
		600 V	—	—	—	—	—	—	—	—	—	—	—
		≤ 72 V	25 A	27 A	30 A	45 A	55 A	60 A	70 A	100 A	110 A	120 A	—
		110 V	25 A	27 A	30 A	45 A	55 A	60 A	70 A	100 A	110 A	120 A	—
220 V		25 A	27 A	30 A	45 A	55 A	60 A	70 A	100 A	110 A	120 A	—	
440 V		6 A	7 A	8 A	—	—	—	—	—	—	—	—	
600 V		—	—	—	—	—	—	—	—	—	—	—	
Utilization Category DC-5, L/R ≤ 7.5 ms		≤ 72 V	9 A	12 A	16 A	25 A	30 A	40 A	50 A	50 A	63 A	75 A	85 A
		110 V	4 A	4 A	4 A	—	—	—	—	—	—	—	85 A
		220 V	—	—	—	—	—	—	—	—	—	—	85 A
		440 V	—	—	—	—	—	—	—	—	—	—	35 A
		600 V	—	—	—	—	—	—	—	—	—	—	—
		≤ 72 V	25 A	27 A	30 A	45 A	55 A	60 A	70 A	100 A	110 A	120 A	—
		110 V	10 A	15 A	20 A	30 A	45 A	50 A	70 A	80 A	90 A	100 A	—
		220 V	4 A	4 A	4 A	—	—	—	—	—	—	—	—
		440 V	—	—	—	—	—	—	—	—	—	—	—
		600 V	—	—	—	—	—	—	—	—	—	—	—
		≤ 72 V	25 A	27 A	30 A	45 A	55 A	60 A	70 A	100 A	110 A	120 A	—
		110 V	25 A	27 A	30 A	45 A	55 A	60 A	70 A	100 A	110 A	120 A	—
220 V		9 A	12 A	16 A	25 A	30 A	40 A	50 A	50 A	63 A	75 A	—	
440 V		—	—	—	—	—	—	—	—	—	—	—	
600 V		—	—	—	—	—	—	—	—	—	—	—	

## Contactor Selection

## d.c. circuit switching

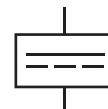









■ For the standard contactors, the tables indicate the  $I_e$  maximum operating currents depending on: the utilization category (i.e. L/R) DC-1, DC-3, DC-5 as defined in the IEC 60947-4-1 publication, the operating voltage  $U_e$  and the pole coupling details.

Ampere values quoted in these tables are valid for a

-25 ... +70° C temperature close to the contactors, as long as the **AC-1 Ampere values** for the corresponding ambient temperature are not exceeded.

■ Maximum switching frequency: 300 cycles/h

■ For switching higher d.c. ratings, we recommend the use of bar mounted contactors, R series (63 ... 2000 A).

a.c. operated contactors		A 95	A 110	A 145	A 185	A 210	A 260	A 300	—	—	—	—		
a.c./d.c. operated (electronic coil interface)		AF 95	AF 110	AF 145	AF 185	AF 210	AF 260	AF 300	AF 400	AF 460	AF 580	AF 750		
d.c. operated contactors		AE 95	AE 110	—	—	—	—	—	—	—	—	—		
Utilization Category DC-1, L/R ≤ 1 ms		≤ 110 V	—	—	—	—	—	—	600 A	700 A	800 A	1050 A		
		≤ 110 V	145 A	160 A	250 A	275 A	350 A	400 A	450 A	600 A	700 A	800 A	1050 A	
		220 V	—	—	—	—	—	—	—	600 A	700 A	800 A	1050 A	
		≤ 110 V	145 A	160 A	250 A	275 A	350 A	400 A	450 A	600 A	700 A	800 A	1050 A	
		220 V	145 A	160 A	250 A	275 A	350 A	400 A	450 A	600 A	700 A	800 A	1050 A	
		440 V	—	—	—	—	—	—	—	600 A	700 A	800 A	1050 A	
		600 V	—	—	—	—	—	—	—	600 A	700 A	800 A	1050 A	
	Utilization Category DC-3, L/R ≤ 2.5 ms		≤ 110 V	—	—	—	—	—	—	600 A	700 A	800 A	1050 A	
			≤ 110 V	145 A	160 A	250 A	275 A	350 A	400 A	450 A	600 A	700 A	800 A	1050 A
			220 V	—	—	—	—	—	—	—	600 A	700 A	800 A	1050 A
			≤ 110 V	145 A	160 A	250 A	275 A	350 A	400 A	450 A	600 A	700 A	800 A	1050 A
			220 V	145 A	160 A	250 A	275 A	350 A	400 A	450 A	600 A	700 A	800 A	1050 A
440 V			—	—	—	—	—	—	—	600 A	700 A	800 A	1050 A	
600 V			—	—	—	—	—	—	—	600 A	700 A	800 A	1050 A	
Utilization Category DC-5, L/R ≤ 15 ms			≤ 110 V	—	—	—	—	—	—	600 A	700 A	800 A	1050 A	
			≤ 110 V	145 A	160 A	250 A	275 A	350 A	400 A	450 A	600 A	700 A	800 A	1050 A
			220 V	—	—	—	—	—	—	—	600 A	700 A	800 A	1050 A
			≤ 110 V	145 A	160 A	250 A	275 A	350 A	400 A	450 A	600 A	700 A	800 A	1050 A
			220 V	145 A	160 A	250 A	275 A	350 A	400 A	450 A	600 A	700 A	800 A	1050 A
	440 V		—	—	—	—	—	—	—	600 A	700 A	800 A	1050 A	
	600 V		—	—	—	—	—	—	—	600 A	700 A	800 A	1050 A	

## Auxiliary Contacts for Safety Circuits 3-Pole Contactors

### Mechanically Linked Contact Elements for Contactors

 ...also known as “forced contacts”, “positively activated contacts” or “linked contacts”.

Definitions from standards: mechanically linked contact elements according to IEC 60947-5-1, Annex L 3.0. Combination of “n” Make auxiliary contact element(s) and “m” Break auxiliary contact element(s) are designed in such a way that they cannot be in the closed position simultaneously.

The table below gives the contactors that offer mechanically linked auxiliary contacts according to the IEC 60947-5-1, Annex L.

### Mirror Contacts for Contactors

 Definitions from standards: mirror contact according to IEC 60947-4-1, Annex F 2.1.

Normally closed auxiliary contact (N.C.) which cannot be in the closed position simultaneously with the normally open (N.O.) main contact.

The table below indicates the contactors that offer a built-in auxiliary mirror contact.



The CA5-13, CA5-22, CA5-31, CA5-04 and CA5-01 (respectively 4-pole and 1-pole auxiliary contact blocks) and the CAL5-11 (2-pole auxiliary contact block) when fitted on A 9 ... A 75, AF 45 ... AF 75 or AL 9 ... AL 40 contactors have their own N.C. auxiliary mirror contacts.

The CAL18-11 2-pole auxiliary contact blocks when fitted on A 95 ... A 300 and AF 95 ... AF 750 contactors have their own N.C. auxiliary mirror contacts.

For AF 1350 and AF 1650 use 2 N.C. auxiliary contacts in series for mirror contact, one CAL18-11 on each side of the contactor.

### 3-Pole A... and AL... Contactors

### 1 CA5-... 4-pole Add-On Auxiliary Contact Block

Contactor	Built-In Auxiliary Contacts 	+	Add-On Auxiliary Contact Blocks			
			CA5-22... 	or	CA5-31... 	or
A/AL 9-30-10	1 —		2 2		3 1	n/a
A/AL 9-30-01	— 1		2 2		3 1	4 —
A/AL 12-30-10	1 —		2 2		3 1	n/a
A/AL 12-30-01	— 1		2 2		3 1	4 —
A/AL 16-30-10	1 —		2 2		3 1	n/a
A/AL 16-30-01	— 1		2 2		3 1	4 —
A/AL 26-30-10	1 —		2 2		3 1	n/a
A/AL 26-30-01	— 1		2 2		3 1	4 —
A/AL 30-30-10	1 —		2 2		3 1	n/a
A/AL 30-30-01	— 1		2 2		3 1	4 —
A/AL 40-30-10	1 —		2 2		3 1	n/a
A/AL 40-30-01	— 1		2 2		3 1	4 —

The information provided for AL... contactors can also be used for AL...Z... contactors. For each contactor type, see Accessory Fitting Details.

### Direct Opening Action of N.C. Built-In Auxiliary Contacts

Annex K2.1 of IEC 60947-5-1 defines a control switch with direct opening action: “the full contact opening of the break contact element(s) is obtained when the actuator is moved through the direct opening travel by applying the force stated by the manufacturer”.

The N.C. built-in auxiliary contacts of contactors **ARE NOT COVERED** by the annex K. Nevertheless, N.C. auxiliary contacts are designed to have “direct opening action” and are suitable for uses such as lifts/elevators, according to EN 81-1.



# A..., AL..., AE..., and AF... Contactors Technical Data

## Main Pole Utilization Characteristics according to IEC

Contactor	A 9	A 12	A 16	A 26	A 30	A 40	A 45	A 50	A 63	A 75	A 95	A 110	
	AL 9	AL 12	AL 16	AL 26	AL 30	AL 40	-	-	-	-	-	-	
	-	-	-	-	-	-	AE 45	AE 50	AE 63	AE 75	AE 95	AE 110	
	-	-	-	-	-	-	AF 45	AF 50	AF 63	AF 75	AF 95	AF 110	
Rated operational voltage $U_e$ max.	690 V	690 V	690 V	690 V	690 V	690 V	1000 V (A..., AL..., AE...)/ 690V (AF...)					1000 V	1000 V
Rated frequency limits	25...400 Hz												
Conventional free-air thermal current $I_{th}$ acc. to IEC 60947-4-1, open contactors, $0 \leq 40^\circ C$ with conductor cross-sectional area	26 A 4 mm <sup>2</sup>	28 A 4 mm <sup>2</sup>	30 A 4 mm <sup>2</sup>	45 A 6 mm <sup>2</sup>	65 A 16 mm <sup>2</sup>	65 A 16 mm <sup>2</sup>	100 A 35 mm <sup>2</sup>	100 A 35 mm <sup>2</sup>	125 A 50 mm <sup>2</sup>	125 A 50 mm <sup>2</sup>	145 A 50 mm <sup>2</sup>	160 A 70 mm <sup>2</sup>	
Rated operational current $I_e$ / AC-1 for air temperature close to contactor $(0 \leq 40^\circ C)$ $U_e$ max. 690 V - 50/60 Hz $(0 \leq 55^\circ C)$ $(0 \leq 70^\circ C)$ with conductor cross-sectional area	25 A 22 A 18 A 2.5 mm <sup>2</sup>	27 A 25 A 20 A 4 mm <sup>2</sup>	30 A 27 A 23 A 4 mm <sup>2</sup>	45 A 40 A 32 A 6 mm <sup>2</sup>	55 A 55 A 39 A 10 mm <sup>2</sup>	60 A 60 A 42 A 16 mm <sup>2</sup>	70 A 60 A 50 A 25 mm <sup>2</sup>	100 A 85 A 70 A 35 mm <sup>2</sup>	115 A 95 A 80 A 50 mm <sup>2</sup>	125 A 105 A 85 A 50 mm <sup>2</sup>	145 A 135 A 115 A 50 mm <sup>2</sup>	160 A 145 A 130 A 70 mm <sup>2</sup>	
Utilization category AC-3 for air temperature close to contactor $\leq 55^\circ C$ Max. rated operational current $I_e$ AC-3 (1)	220-230-240 V												
3-phase motors	9 A	12 A	17 A	26 A	33 A	40 A	40 A	53 A	65 A	75 A	96 A	110 A	
380-400 V	9 A	12 A	17 A	26 A	32 A	37 A	37 A	50 A	65 A	75 A	96 A	110 A	
415 V	9 A	12 A	17 A	26 A	32 A	37 A	37 A	50 A	65 A	75 A	96 A	110 A	
440 V	9 A	12 A	16 A	26 A	32 A	37 A	37 A	45 A	65 A	70 A	93 A	100 A	
500 V	9 A	12 A	14 A	22 A	28 A	33 A	33 A	45 A	55 A	65 A	80 A	100 A	
690 V	7 A	9 A	10 A	17 A(4)	21 A(4)	25 A(4)	25 A	35 A	43 A	46 A	65 A	82 A	
1000 V	-	-	-	-	-	-	-	23 A(5)	25 A(5)	28 A(5)	30 A	30 A	
Rated operational power AC-3 (1)	220-230-240 V												
1500 rpm 50 Hz	2.2 kW	3 kW	4 kW	6.5 kW	9 kW	11 kW	11 kW	15 kW	18.5 kW	22 kW	25 kW	30 kW	
1800 rpm 60 Hz	4 kW	5.5 kW	7.5 kW	11 kW	15 kW	18.5 kW	18.5 kW	22 kW	30 kW	37 kW	45 kW	55 kW	
3-phase motors	4 kW	5.5 kW	9 kW	11 kW	15 kW	18.5 kW	18.5 kW	25 kW	37 kW	40 kW	55 kW	59 kW	
415 V	4 kW	5.5 kW	9 kW	15 kW	18.5 kW	22 kW	22 kW	25 kW	37 kW	40 kW	55 kW	59 kW	
440 V	4 kW	5.5 kW	9 kW	15 kW	18.5 kW	22 kW	22 kW	25 kW	37 kW	40 kW	55 kW	59 kW	
500 V	5.5 kW	7.5 kW	9 kW	15 kW	18.5 kW	22 kW	22 kW	30 kW	37 kW	45 kW	55 kW	59 kW	
690 V	5.5 kW	7.5 kW	9 kW	15 kW(4)	18.5 kW(4)	22 kW(4)	22 kW	30 kW	37 kW	40 kW	55 kW	75 kW	
1000 V	-	-	-	-	-	-	-	30 kW(5)	33 kW(5)	37 kW(5)	40 kW	40 kW	
Rated operational current $I_e$ / AC-8a without thermal O/L relay - $U_e$ 400 V - $0 \leq 40^\circ C$	12 A	16 A	22 A	30 A	40 A	50 A	-	63 A	85 A	95 A	120 A	140 A	
Rated making capacity AC-3	10 x $I_e$ AC-3 acc. to IEC 60947-4-1												
Rated breaking capacity AC-3	8 x $I_e$ AC-3 acc. to IEC 60947-4-1												
Short-circuit protection for contactors without thermal O/L relay - Motor protection excluded (2)	$U_e \leq 500$ V a.c. - gG type fuse												
$U_e \leq 500$ V a.c. - gG type fuse	25 A	32 A	32 A	50 A	63 A	63 A	80 A	100 A	125 A	160 A	160 A	200 A	
Rated short-time withstand current $I_{cw}$ at $40^\circ C$ ambient temp., 1 s in free air, from a cold state	250 A	280 A	300 A	400 A	600 A	600 A	1000 A	1000 A	1000 A	1000 A	1320 A	1320 A	
10 s	100 A	120 A	140 A	210 A	400 A	400 A	650 A	650 A	650 A	650 A	800 A	800 A	
30 s	60 A	70 A	80 A	110 A	225 A	225 A	370 A	370 A	370 A	370 A	500 A	500 A	
1 min	50 A	55 A	60 A	90 A	150 A	150 A	250 A	250 A	250 A	250 A	350 A	350 A	
15 min 26 A	28 A	30 A	45 A	65 A	65 A	110 A	110 A	135 A	135 A	160 A	175 A		
Maximum breaking capacity (4) $\cos \Phi = 0.45$ at 440 V ( $\cos \Phi = 0.35$ for $I_e > 100$ A) at 690 V	250 A	250 A	250 A	420 A	820 A(4)	820 A(4)	900 A	1300 A	1300 A	1300 A	1160 A	1160 A	
	90 A(4)	90 A(4)	90 A(4)	170 A(4)	340 A(4)	340 A(4)	490 A	630 A	630 A	630 A	800 A	800 A	
Heat dissipation per pole $I_e$ / AC-1 $I_e$ / AC-3	0.8 W	1 W	1.2 W	1.8 W	2.5 W	3 W	2.5 W	5 W	6.5 W	7 W	6.5 W	7.5 W	
	0.1 W	0.2 W	0.35 W	0.6 W	0.9 W	1.3 W	0.65 W	1.3 W	1.5 W	2 W	2.7 W	3.6 W	
Max. electrical switching frequency for AC-1 (cycles/h) for AC-2 (cycles/h) for AC-3 (cycles/h) for AC-4 (cycles/h)	600	600	600	600	600	600	600 (A..., AL...)/ 300 for AE..., AF...)					300	300
	300	300	300	300	300	300	150	150	150	150	150	150	
	1200	1200	1200	1200	1200	1200	600 (A..., AL...)/ 300 for AE..., AF...)					300	300
	300	300	300	300	300	300	150	150	150	150	150	150	
Mechanical durability millions of operating cycles max. switching frequency (cycles/h)	10 (A..., AL..., AF...)/ 5 (AE...)												
	3600 (A..., AL..., AE...)/ 300 (AF...)												

(1) For the corresponding kW/A or hp/A values of 1500 rpm, 50Hz or 1800 r.p.m., 60Hz, 3-phase motors, see "Motor Rated Operational Powers and Currents".

(2) For the protection of motor starters against short circuits, see "Coordination with Short-circuit Protection Devices".

(5) AF... contactors excluded.

(3) AC-3, 690 V values for AL... contactors

Types	AL 26	AL 30	AL 40
Rated current $I_e$	13 A	18 A	21 A
Rated power	11 kW	15 kW	18.5 kW

(4) Max. breaking capacity for AL... contactors

Types	AL 9 ... AL 16	AL 26	AL 30, AL 40
440 V	250 A	420 A	470 A
690 V	100 A	106 A	175 A

# A... and AF... Contactors Technical Data

## Main Pole Utilization Characteristics according to IEC

Contactor	A 145 AF 145	A 185 AF 185	A 210 AF 210	A 260 AF 260	A 300 AF 300	- AF 400	- AF 460	- AF 580	- AF 750	- AF 1350	- AF 1650		
Rated operational voltage $U_e$ max.	1000 V	1000 V	690 V	690 V	690 V	1000 V	1000 V	1000 V	1000 V	1000 V	1000 V		
Rated frequency limits	25...400 Hz												
Conventional free-air thermal current $I_{th}$ acc. to IEC 60947-4-1, open contactors, $0 \leq 40^\circ\text{C}$ with conductor cross-sectional area (mm <sup>2</sup> )	250 A 120	275 A 150	350 A 185	400 A 240	500 A 300(5)	600 A 2x185	700 A 2x240	800 A 2x240	1050 A 2x50x8(4)	1350 A 2x100x5(4)	1650 A 3x100x5(4)		
Rated operational current $I_e$ / AC-1 for air temperature close to contactor $U_e$ max. 690 V - 50/60 Hz	$0 \leq 40^\circ\text{C}$ : 250 A $0 \leq 55^\circ\text{C}$ : 230 A $0 \leq 70^\circ\text{C}$ : 180 A	$0 \leq 40^\circ\text{C}$ : 275 A $0 \leq 55^\circ\text{C}$ : 250 A $0 \leq 70^\circ\text{C}$ : 180 A	$0 \leq 40^\circ\text{C}$ : 350 A $0 \leq 55^\circ\text{C}$ : 300 A $0 \leq 70^\circ\text{C}$ : 240 A	$0 \leq 40^\circ\text{C}$ : 400 A $0 \leq 55^\circ\text{C}$ : 350 A $0 \leq 70^\circ\text{C}$ : 290 A	$0 \leq 40^\circ\text{C}$ : 500 A(5) $0 \leq 55^\circ\text{C}$ : 400 A $0 \leq 70^\circ\text{C}$ : 325 A	$0 \leq 40^\circ\text{C}$ : 600 A $0 \leq 55^\circ\text{C}$ : 500 A $0 \leq 70^\circ\text{C}$ : 400 A	$0 \leq 40^\circ\text{C}$ : 700 A $0 \leq 55^\circ\text{C}$ : 600 A $0 \leq 70^\circ\text{C}$ : 480 A	$0 \leq 40^\circ\text{C}$ : 800 A $0 \leq 55^\circ\text{C}$ : 700 A $0 \leq 70^\circ\text{C}$ : 580 A	$0 \leq 40^\circ\text{C}$ : 1050 A $0 \leq 55^\circ\text{C}$ : 875 A $0 \leq 70^\circ\text{C}$ : 720 A	$0 \leq 40^\circ\text{C}$ : 1350 A $0 \leq 55^\circ\text{C}$ : 1150 A $0 \leq 70^\circ\text{C}$ : 1000 A	$0 \leq 40^\circ\text{C}$ : 1650 A $0 \leq 55^\circ\text{C}$ : 1450 A $0 \leq 70^\circ\text{C}$ : 1270 A		
for air temperature close to contactor $U_e$ max. 1000 V - 50/60 Hz	$0 \leq 40^\circ\text{C}$ : 180 A $0 \leq 55^\circ\text{C}$ : 180 A $0 \leq 70^\circ\text{C}$ : 180 A	$0 \leq 40^\circ\text{C}$ : 200 A $0 \leq 55^\circ\text{C}$ : 200 A $0 \leq 70^\circ\text{C}$ : 180 A	$0 \leq 40^\circ\text{C}$ : - $0 \leq 55^\circ\text{C}$ : - $0 \leq 70^\circ\text{C}$ : -	$0 \leq 40^\circ\text{C}$ : - $0 \leq 55^\circ\text{C}$ : - $0 \leq 70^\circ\text{C}$ : -	$0 \leq 40^\circ\text{C}$ : - $0 \leq 55^\circ\text{C}$ : - $0 \leq 70^\circ\text{C}$ : -	$0 \leq 40^\circ\text{C}$ : 600 A $0 \leq 55^\circ\text{C}$ : 500 A $0 \leq 70^\circ\text{C}$ : 400 A	$0 \leq 40^\circ\text{C}$ : 700 A $0 \leq 55^\circ\text{C}$ : 600 A $0 \leq 70^\circ\text{C}$ : 480 A	$0 \leq 40^\circ\text{C}$ : 800 A $0 \leq 55^\circ\text{C}$ : 700 A $0 \leq 70^\circ\text{C}$ : 580 A	$0 \leq 40^\circ\text{C}$ : 1000 A $0 \leq 55^\circ\text{C}$ : 875 A $0 \leq 70^\circ\text{C}$ : 720 A	$0 \leq 40^\circ\text{C}$ : 1350 A $0 \leq 55^\circ\text{C}$ : 1150 A $0 \leq 70^\circ\text{C}$ : 1000 A	$0 \leq 40^\circ\text{C}$ : 1650 A $0 \leq 55^\circ\text{C}$ : 1450 A $0 \leq 70^\circ\text{C}$ : 1270 A		
with conductor cross-sectional area (mm <sup>2</sup> )	120	150	185	240	240(5)	2x185	2x240	2x240	2x50x8(4)	2x100x5(4)	3x100x5(4)		
Utilization category AC-3 for air temperature close to contactor $\leq 55^\circ\text{C}$ Max. rated operational current $I_e$ AC-3 (1)													
3-phase motors	220-230-240 V 380-400 V 415 V 440 V 500 V 690 V 1000 V	145 A 145 A 145 A 145 A 145 A 120 A 80 A	185 A 185 A 185 A 185 A 170 A 170 A 95 A	210 A 210 A 210 A 210 A 210 A 210 A -	260 A 260 A 260 A 240 A 280 A 220 A -	305 A 305 A 300 A 280 A 280 A 280 A -	400 A 400 A 400 A 400 A 400 A 350 A 155 A	460 A 460 A 460 A 460 A 460 A 400 A 200 A	580 A 580 A 580 A 580 A 580 A 500 A 250 A	750 A 750 A 750 A 750 A 750 A 650 A 300 A	860 A 860 A 860 A 860 A 800 A 800 A -	1050 A 1050 A 1050 A 1050 A 950 A 950 A -	
Rated operational power AC-3 (1)	1500 rpm 50 Hz 1800 rpm 60 Hz	45 kW 75 kW	55 kW 90 kW	59 kW 110 kW	80 kW 140 kW	90 kW 160 kW	110 kW 200 kW	132 kW 250 kW	160 kW 315 kW	220 kW 400 kW	257 kW 475 kW	315 kW 560 kW	
3-phase motors	415 V 440 V 500 V 690 V 1000 V	75 kW 75 kW 90 kW 110 kW 110 kW	90 kW 90 kW 110 kW 132 kW 132 kW	110 kW 110 kW 132 kW 160 kW 160 kW	140 kW 140 kW 180 kW 200 kW 200 kW	160 kW 160 kW 200 kW 250 kW 250 kW	220 kW 220 kW 250 kW 315 kW 315 kW	250 kW 250 kW 315 kW 355 kW 355 kW	355 kW 355 kW 400 kW 500 kW 500 kW	425 kW 450 kW 520 kW 600 kW 600 kW	500 kW 560 kW 560 kW 750 kW 750 kW	600 kW 670 kW 700 kW 900 kW 900 kW	
Rated making capacity AC-3	10 x $I_e$ AC-3 acc. to IEC 60947-4-1												
Rated breaking capacity AC-3	8 x $I_e$ AC-3 acc. to IEC 60947-4-1												
Short-circuit protection for contactors without thermal O/L relay - Motor protection excluded (2)											PLEASE CONSULT ABB FOR COORDINATION WITH CIRCUIT BREAKER		
$U_e \leq 500$ V a.c. - gG type fuse	315 A	355 A	400 A	500 A	500 A	630 A	800 A	1000 A	1000 A				
Rated short-time withstand current $I_{sw}$ at $40^\circ\text{C}$ ambient temp., in free air, from a cold state	1 s 10 s 30 s 1 min 15 min	1800 A 1200 A 800 A 600 A 280 A	2000 A 1500 A 1000 A 800 A 320 A	2500 A 1700 A 1200 A 1000 A 400 A	3500 A 2400 A 1500 A 1100 A 500 A	3500 A 2400 A 1500 A 1100 A 500 A	4600 A 4400 A 3100 A 2500 A 840 A	4600 A 4400 A 3100 A 2500 A 840 A	7000 A 6400 A 4500 A 3500 A 1300 A	7000 A 6400 A 4500 A 3500 A 1300 A	10000 A 8000 A 6000 A 4500 A 1600 A	12000 A 10000 A 7500 A 5500 A 2200 A	
Maximum breaking capacity (4)	$\cos\varphi = 0.45$ ( $\cos\varphi = 0.35$ for $I_e > 100$ A)	at 440 V at 690 V	1500 A 1200 A	2000 A 1600 A	2300 A 2000 A	2600 A 2400 A	3000 A 2500 A	4000 A 3500 A	5000 A 4500 A	6000 A 5000 A	7500 A 7000 A	10000 A -	12000 A -
Heat dissipation per pole	$I_e$ / AC-1 $I_e$ / AC-3	13 W 5 W	16 W 8 W	18 W 9 W	25 W 14 W	32 W 18 W	30 W 16 W	42 W 21 W	32 W 17 W	50 W 28 W	80 W 50 W	80 W 50 W	
Max. electrical switching frequency	for AC-1 (cycles/h) for AC-2 (cycles/h) for AC-3 (cycles/h) for AC-4 (cycles/h)	300 150 300 150	300 150 300 150	300 150 300 150	300 150 300 150	300 150 300 150	300 60 300 60	300 60 300 60	300 60 300 60	300 60 300 60	60 60 60 60	60 60 60 60	
Mechanical durability	millions of operating cycles max. switching frequency (cycles/h)	5 3600 (A.) / 300 (AF.)	5	5	5	5	3	3	3	3	0.5	0.5	

(1) For the corresponding kW/A or hp/A values of 1500 rpm, 50Hz or 1800 r.p.m., 60Hz, 3-phase motors, see "Motor Rated Operational Powers and Currents".  
(2) For the protection of motor starters against short circuits,

see "Coordination with Short-circuit Protection Devices".  
(3) Conductors with preparation.  
(4) Dimensions of the bars (in mm).

(5) For currents above 450 A use 300 mm<sup>2</sup> and terminal extension/enlargement pieces (LX 300 / LW 300: see "Accessories".

# A..., AL..., AE..., and AF... Contactors Technical Data

## Main Pole Utilization Characteristics according to UL/CSA

Contactor	A 9	A 12	A 16	A 26	A 30	A 40	A 45	A 50	A 63	A 75	A 95	A 110	
	AL 9	AL 12	AL 16	AL 26	AL 30	AL 40	-	-	-	-	-	-	
	-	-	-	-	-	-	AE 45	AE 50	AE 63	AE 75	AE 95	AE 110	
	-	-	-	-	-	-	AF 45	AF 50	AF 63	AF 75	AF 95	AF 110	
NEMA size	00	0	-	1	1P	-	2	2	-	3	-	-	
General use rating													
Amp-rating 600 V	21 A	25 A	30 A	40 A	50 A	60 A	80 A	80 A	90 A	105 A	125 A	140 A	
3-phase motor rating													
Amp-rating (1)													
200-208 V	7.8 A	11 A	17.5 A	25.3 A	32.2 A	32.2 A	48.3 A	48.3 A	62.1 A	78.2 A	92 A	92 A	
220-240 V	6.8 A	9.6 A	15.2 A	28 A	28 A	42 A	54 A	54 A	68 A	80 A	80 A	104 A	
440-480 V	7.6 A	11 A	14 A	27 A	34 A	40 A	52 A	52 A	77 A	77 A	77 A	96 A	
550-600 V	9 A	11 A	17 A	27 A	32 A	41 A	52 A	52 A	77 A	77 A	77 A	99 A	
Motor power (1)													
200-208 V	2 hp	3 hp	5 hp	7.5 hp	10 hp	10 hp	15 hp	15 hp	20 hp	25 hp	30 hp	30 hp	
220-240 V	2 hp	3 hp	5 hp	10 hp	10 hp	15 hp	20 hp	20 hp	25 hp	30 hp	30 hp	40 hp	
440-480 V	5 hp	7.5 hp	10 hp	20 hp	25 hp	30 hp	40 hp	40 hp	60 hp	60 hp	60 hp	75 hp	
550-600 V	7.5 hp	10 hp	15 hp	25 hp	30 hp	40 hp	50 hp	50 hp	75 hp	75 hp	75 hp	100 hp	
Short-circuit protection													
for contactors without thermal O/L relay - Motor protection excluded													
Fuse rating	35 A	35 A	60 A	90 A	150 A	150 A	175 A	175 A	200 A	200 A	200 A	200 A	
Fuse type, 600 V	FRS-R	FRS-R	FRS-R	FRS-R	FRS-R	FRS-R	FRS-R	FRS-R	J	J	J	J	
Max. electrical switching frequency													
for general use (cycles/h)	600	600	600	600	600	600	600 (A..., AL...)	300 (AF..., AE...)				300	300
for motor use (cycles/h)	1200	1200	1200	1200	1200	1200	600 (A..., AL...)	300 (AF..., AE...)				300	300

(1) For the corresponding kW/A or hp/A values of 1500 r.p.m., 50Hz or 1800 r.p.m., 60Hz, 3-phase motors, see "Motor Rated Operational Powers and Currents".

## General Technical Data

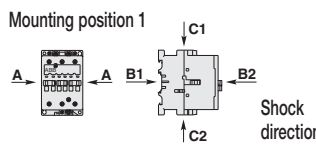
Contactor	A 9	A 12	A 16	A 26	A 30	A 40	A 45	A 50	A 63	A 75	A 95	A 110
	AL 9	AL 12	AL 16	AL 26	AL 30	AL 40	-	-	-	-	-	-
	-	-	-	-	-	-	AE 45	AE 50	AE 63	AE 75	AE 95	AE 110
	-	-	-	-	-	-	AF 45	AF 50	AF 63	AF 75	AF 95	AF 110
Rated insulation voltage U <sub>i</sub> according to IEC 60947-4-1	1000 V											
according to UL/CSA	600 V											
Rated impulse withstand voltage U <sub>imp</sub>	8 kV											
Standards	Devices complying with IEC 60947-1 / 60947-4-1 and EN 60947-1 / 60947-4-1											
Air temperature close to contactor fitted with thermal O/L relay	see "Conditions for use", for control voltage limits and authorized mounting positions											
without thermal O/L relay	-25° C to +55° C											
for storage	-40° C to +70° C (1)											-40° C to +70° C
Climatic withstand	acc. to IEC 60068-2-30 and 60068-2-11 - UTE C 63-100 specification II											acc. to IEC 68-2-30
Operating altitude	≤ 3000 m											
Shock withstand acc. IEC 60068-2-27 and EN 60068-2-27	1/2 sinusoidal shock for 11 ms: no change in contact position											
Mounting position 1												
	A 9...A 40 contactors			AL 9...AL 40 contactors			A 45...A 110 and AF 45...AF 110 contactors AE 45...AE 110 contactors					
Shock direction	Closed position	Open position	Closed position	Open position	Closed position	Open position	Closed position	Open position	Closed position	Open position	<i>Note : For A 95, AE 95, AF 95, A 110, AE110, AF 110 contactors, these values are not valid for rail mounting.</i>	
A	20 g	20 g	20 g	10 g	20 g	10 g	20 g	20 g	20 g	20 g		
B1	10 g	5 g	15 g	5 g	10 g	5 g	10 g	10 g	15 g (3)	5 g (2)		
B2	15 g	15 g	10 g	10 g	15 g (3)	15 g (3)	15 g (3)	15 g (3)	15 g (3)	15 g (3)		
C1	20 g	20 g	20 g	8 g	20 g	8 g	20 g	20 g	20 g	20 g		
C2	20 g	20 g	14 g	8 g	20 g	8 g	20 g	20 g	20 g	20 g		

(2) 3 g for AF 45-22, AE 45-22, AF 75-22 and AE 75-22

(3) 10 g for AF 45-22, AE 45-22, AF 75-22 and AE 75-22

## A.. and AF.. Contactors Technical Data

### Main Pole Utilization Characteristics according to UL/CSA

Contactor	A 145 AF 145	A 185 AF 185	A 210 AF 210	A 260 AF 260	A 300 AF 300	- AF 400	- AF 460	- AF 580	- AF 750	- AF 1350	- AF 1650	
NEMA size	4	-	-	5	-	-	6	-	7	-	8	
<b>General use rating</b>												
Amp-rating	600 V	230 A	250 A	300 A	350 A	400 A	550 A	650 A	750 A	900 A	1350 A	1650 A
<b>3-phase motor rating</b>												
Amp-rating (1)	200-208 V	119.6 A	149.5 A	166.8 A	220.8 A	285.2 A	358.8 A	414 A	552 A	692.3 A	954 A	1030 A
	220-240 V	130 A	145 A	192 A	248 A	248 A	360 A	480 A	604 A	722 A	954 A	1030 A
	440-480 V	124 A	156 A	180 A	240 A	302 A	414 A	477 A	590 A	722 A	954 A	1030 A
	550-600 V	125 A	144 A	192 A	242 A	289 A	382 A	472 A	578 A	672 A	944 A	1050 A
Motor power (1)	200-208 V	40 hp	50 hp	60 hp	75 hp	100 hp	125 hp	150 hp	200 hp	250 hp	-	-
	220-240 V	50 hp	60 hp	75 hp	100 hp	100 hp	150 hp	200 hp	250 hp	300 hp	400 hp	450 hp
	440-480 V	100 hp	125 hp	150 hp	200 hp	250 hp	350 hp	400 hp	500 hp	600 hp	800 hp	900 hp
	550-600 V	125 hp	150 hp	200 hp	250 hp	300 hp	400 hp	500 hp	600 hp	700 hp	1000 hp	1150 hp
<b>Short-circuit protection for contactors</b>												
without thermal O/L relay - Motor protection excluded												
Fuse rating		300	400	800	800	800	1000	1000	1200	1200	PLEASE CONSULT ABB FOR COORDINATION WITH CIRCUIT BREAKER	
Fuse type, 600 V		J/K5	J/K5	J/K5	J/K5	J/K5	L	L	L	L		
<b>Max. electrical switching frequency</b>												
for general use (cycles/h)		300	300	300	300	300	300	300	300	300	60	60
for motor use (cycles/h)		300	300	300	300	300	300	300	300	300	60	60

(1) For the corresponding kW/A or hp/A values of 1500 r.p.m., 50Hz or 1800 r.p.m., 60Hz, 3-phase motors, see "Motor Rated Operational Powers and Currents".

### General Technical Data

Contactor	A 145 AF 145	A 185 AF 185	A 210 AF 210	A 260 AF 260	A 300 AF 300	- AF 400	- AF 460	- AF 580	- AF 750	- AF 1350	- AF 1650
<b>Rated insulation voltage U<sub>i</sub></b>											
according to IEC 60947-4-1	1000 V	1000 V	1000 V	1000 V	1000 V	1000 V	1000 V	1000 V	1000 V	1000 V	1000 V
according to UL/CSA	600 V	600 V	600 V	600 V	600 V	600 V	600 V	600 V	600 V	600 V	600 V
<b>Rated impulse withstand voltage U<sub>imp.</sub></b>											
	8 kV	8 kV	8 kV	8 kV	8 kV	8 kV	8 kV	8 kV	8 kV	8 kV	8 kV
<b>Standards</b>											
	Devices complying with IEC 60947-1 / 60947-4-1 and EN 60947-1 / 60947-4-1										
<b>Air temperature close to contactor</b>											
fitted with thermal O/L relay	see "Conditions for use", for control voltage limits and authorized mounting positions										
fitted with electronic O/L relay	-25° C to +55° C										
without O/L relay	-25° C to +70° C										
for storage	-40° C to +70° C										
<b>Climatic withstand</b>											
	acc. to IEC 60068-2-30										
<b>Operating altitude</b>											
	< 3000 m										

#### Shock withstand

acc. IEC 60068-2-27 and EN 60068-2-27

Mounting position 1

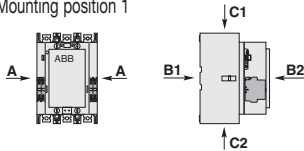

1/2 sinusoidal shock for 30 ms: no change in contact position

5 g in all directions (A, B1, B2, C1, C2)

## A... and AF... Contactors Technical Data

### Magnet System Characteristics for A... Contactors

Contactor	A 9	A 12	A 16	A 26	A 30	A 40	A 45	A 50	A 63	A 75	A 95	A 110
Rated control circuit voltage $U_c$												
at 50 Hz	24 ... 690 V											
at 60 Hz	24 ... 690 V											
Coil operating limits acc. to IEC 60947-4-1	0.85 ... 1.1 x $U_c$ (at $0 \leq 55^\circ\text{C}$ )										0.85 ... 1.1 x $U_c$	
	Please also refer to "Conditions for Use"										(at $0 \leq 70^\circ\text{C}$ )	
Drop-out voltage in % of $U_c$	approx. 40 ... 65%											
Coil consumption												
Average pull-in value												
50 Hz	70 VA		120			180			350			
60 Hz	80 VA		140			210			450			
50/60 Hz (1)	74 VA/70 VA		125 VA/120 VA			190 VA/180 VA			410 VA/365 VA			
Average holding value												
50 Hz	8 VA/2 W		12 VA/3 W			18 VA/5.5 W			22 VA/6.5 W			
60 Hz	8 VA/2 W		12 VA/3 W			18 VA/5.5 W			26 VA/8 W			
50/60 Hz (1)	8 VA/2 W		12 VA/3 W			18 VA/5.5 W			27 VA/7.5 W			
Operating time												
between coil energization and:												
N.O. contact closing	10 ms ... 26 ms		8 ms ... 21 ms			8 ms ... 27 ms			10 ms ... 25 ms			
N.C. contact opening	7 ms ... 21 ms		6 ms ... 18 ms			7 ms ... 22			7 ms ... 22 ms			
between coil de-energization and:												
N.O. contact opening	4 ms ... 11 ms		4 ms ... 11 ms			4 ms ... 11 ms			7 ms ... 15 ms			
N.C. contact closing	9 ms ... 16 ms		7 ms ... 14 ms			7 ms ... 14 ms			10 ms ... 18 ms			

(1) 50/60 Hz coils: see "Coil Voltage Code Table".

### Magnet System Characteristics for AF... Contactors

Contactor	-	-	-	-	-	-	AF 45	AF 50	AF 63	AF 75	AF 95	AF 110
Rated control circuit voltage $U_c$												
at 50 Hz	-						48 ... 250 V			48 ... 250 V		
at 60 Hz	-						48 ... 250 V			48 ... 250 V-		
d.c.	-						20 ... 250 V			20 ... 250 V		
Coil operating limits acc. to IEC 60947-4-1	-						0.85 ... 1.1 x $U_c$ (at $0 \leq 55^\circ\text{C}$ )			0.85 ... 1.1 x $U_c$		
	-						Please also refer to "Conditions for Use"			(at $0 \leq 70^\circ\text{C}$ )		
Drop-out voltage in % of $U_c$	-						approx. 55%			approx. 55%		
Coil consumption												
Average pull-in value												
50 Hz	-						210 VA			350 VA		
60 Hz	-						210 VA			350 VA		
d.c.	-						190 W			400 W		
Average holding value												
50 Hz	-						7/2.8 VA/W			7/3.5 VA/W		
60 Hz	-						7/2.8 VA/W			7/3.5 VA/W		
d.c.	-						2.8 W			2 W		
Operating time												
between coil energization and:												
N.O. contact closing	ms						30 ms ... 100 ms			30 ms ... 80 ms		
N.C. contact opening	ms						27 ms ... 95 ms			27 ms ... 77 ms		
between coil de-energization and:												
N.O. contact opening	ms						30 ms ... 110 ms			55 ms ... 125 ms		
N.C. contact closing	ms						35 ms ... 115 ms			60 ms ... 130 ms		

(1) 50/60 Hz coils: see "Coil Voltage Code Table".

## A.. and AF.. Contactors Technical Data

### Magnet System Characteristics for A... Contactors

Contactor		A 145	A 185	A 210	A 260	A 300	-	-	-	-	-	
Rated control circuit voltage $U_c$												
at 50 Hz		24 V ... 690 V		24 V ... 690 V			-	-	-	-	-	
at 60 Hz		24 V ... 690 V		24 V ... 690 V			-	-	-	-	-	
Coil operating limits acc. to IEC 60947-4-1												
		0.85 ... 1.1 x $U_c$ (at $0 \leq 70^\circ\text{C}$ )						-	-	-	-	-
		Please also refer to "Conditions for Use"										
Drop-out voltage in % of $U_c$												
		approx. 40 ... 65%										
Coil consumption												
Average pull-in value												
	50 Hz	550 VA		1350 VA			-	-	-	-	-	
	60 Hz	600 VA		1550 VA			-	-	-	-	-	
	50/60 Hz (1)	700 VA/650 VA		1700 VA/1550 VA			-	-	-	-	-	
Average holding value												
	50 Hz	35 VA/11 W		60 VA/16 W			-	-	-	-	-	
	60 Hz	40 VA/12 W		65 VA/19 W			-	-	-	-	-	
	50/60 Hz (1)	44 VA/13 W		80 VA/21 W			-	-	-	-	-	
Operating time												
between coil energization and:												
	N.O. contact closing	13 ms ... 27 ms		17 ms ... 35 ms			-	-	-	-	-	
	N.C. contact opening	8 ms ... 22 ms		12 ms ... 30 ms			-	-	-	-	-	
between coil de-energization and:												
	N.O. contact opening	5 ms ... 10 ms		7 ms ... 13 ms			-	-	-	-	-	
	N.C. contact closing	9 ms ... 13 ms		10 ms ... 16 ms			-	-	-	-	-	

(1) 50/60 Hz coils: see "Coil Voltage Code Table".

### Magnet System Characteristics for AF... Contactors

Contactor		AF 145	AF 185	AF 210	AF 260	AF 300	AF 400	AF 460	AF 580	AF 750	AF 1350	AF 1650
Rated control circuit voltage $U_c$												
at 50 Hz		48 V ... 250 V		48 V ... 250 V		48 V ... 500 V		48 V ... 500 V		100 V ... 250 V		
at 60 Hz		48 V ... 250 V		48 V ... 250 V		48 V ... 500 V		48 V ... 500 V		100 V ... 250 V		
d.c.		20 V ... 250 V		20 V ... 250 V		24 V ... 500 V		24 V ... 500 V		100 V ... 250 V		
Coil operating limits acc. to IEC 60947-4-1												
		0.85 ... 1.1 x $U_c$ (at $0 \leq 70^\circ\text{C}$ )										
		Please also refer to "Conditions for Use"										
Drop-out voltage in % of $U_c$												
		55%										
Coil consumption												
Average pull-in value												
	50 Hz	430 VA		470 VA		890 VA		850 VA		1900 VA		
	60 Hz	430 VA		470 VA		890 VA		850 VA		1900 VA		
	d.c.	500 W		520 W		990 W		950 W		1700 W		
Average holding value												
	50 Hz	12/3.5 VA/W		10/2.5 VA/W		12/4 VA/W		12/4.5 VA/W		48/17 VA/W		
	60 Hz	12/3.5 VA/W		10/2.5 VA/W		12/4 VA/W		12/4.5 VA/W		48/17 VA/W		
	d.c.	2 W		2 W		4 W		4.5 W		16 W		
Operating time												
coil supply between A1-A2												
between coil energization and:												
	N.O. contact closing	30 ms ... 115 ms		30 ms ... 115 ms		50 ms ... 120 ms		50 ms ... 120 ms		50 ms ... 80 ms		
	N.C. contact opening	30 ms ... 115 ms		30 ms ... 115 ms		50 ms ... 120 ms		50 ms ... 120 ms		50 ms ... 80 ms		
between coil de-energization and:												
	N.O. contact opening	25 ms ... 80 ms		25 ms ... 80 ms		33 ms ... 70 ms		33 ms ... 70 ms		35 ms ... 55 ms		
	N.C. contact closing	25 ms ... 80 ms		25 ms ... 80 ms		33 ms ... 70 ms		33 ms ... 70 ms		35 ms ... 55 ms		
control input for PLCs												
between coil energization and:												
	N.O. contact closing	-	-	-	-	-	40 ms ... 60 ms		40 ms ... 90 ms		40 ms ... 65 ms	
	N.C. contact opening	-	-	-	-	-	40 ms ... 60 ms		40 ms ... 90 ms		40 ms ... 65 ms	
between coil de-energization and:												
	N.O. contact opening	-	-	-	-	-	10 ms ... 30 ms		10 ms ... 30 ms		10 ms ... 30 ms	
	N.C. contact closing	-	-	-	-	-	10 ms ... 30 ms		10 ms ... 30 ms		10 ms ... 30 ms	

## AL... and AE... Contactors Technical Data

### Magnet System Characteristics for AL... and AE... Contactors

Contactor	AL 9	AL 12	AL 16	AL 26	AL 30	AL 40	-	-	-	-	-	-	
	-	-	-	-	-	-	AE 45	AE 50	AE 63	AE 75	AE 95	AE 110	
Rated control circuit voltage $U_c$	12 V d.c. ... 250 (24 and 48 for AL...Z version)						12 V d.c. ... 250 V d.c.						
Coil operating limits acc. to IEC 60947-4-1	0.85 ... 1.1 x $U_c$ (at $0 \leq 55^\circ\text{C}$ )										0.85 ... 1.1 x $U_c$		
	Please also refer to "Conditions for Use"										(at $0 \leq 70^\circ\text{C}$ )		
Drop-out voltage in % of $U_c$	approx. 10 ... 30%						approx. 15 ... 40%						
Coil consumption													
Average pull-in value	3 W (2.4 W for AL...Z version)			3.5 W			200 W			400 W			
Average holding value	3 W (2.4 W for AL...Z version)			3.5 W			4 W			2.4 W			
Coil time constant													
open	L/R	28 ms			38 ms			3 ms			6 ms		
closed	L/R	74 ms			62 ms			15 ms			30 ms ... 40 ms		
Operating time													
between coil energization and:													
N.O. contact closing	50 ms ... 100 ms			55 ms ... 110 ms			13 ms ... 30 ms			15 ms ... 25 ms			
N.C. contact opening	20 ms ... 70 ms			25 ms ... 75 ms			10 ... 27			12 ... 22			
between coil de-energization and:													
N.O. contact opening	10 ms ... 17 ms (1)			12 ms ... 18 ms (1)			5 ms ... 15 ms (1)			15 ms ... 20 ms (1)			
N.C. contact closing	16 ms ... 27 ms (1)			18 ms ... 28 ms (1)			8 ms ... 18 ms (1)			18 ms ... 23 ms (1)			

(1) The use of surge suppressors increases the opening time with a factor of 1.1 to 1.5 for a varistor suppressor and a factor of 1.5 to 3 for a diode suppressor.

## A..., AL... and AL...Z... Contactors Technical Data

### Built-in Auxiliary Contacts

#### Utilization Characteristics according to IEC

Contactor	A 9 AL 9 AL...Z 9	A 12 AL 12 AL...Z 12	A 16 AL 16 AL...Z 16	A 26 AL 26 AL...Z 26	A 30 AL 30 AL...Z 30	A 40 AL 40 AL...Z 40	A 45 - -	A 50 - -	A 63 - -	A 75 - -	A 95 - -	A 110 - -
Rated operational voltage $U_e$ max.	690 V			690 V			690 V				690 V	
Conventional free air thermal current $I_{th} - 0 \leq 40^\circ \text{C}$	16 A			16 A			16 A				16 A	
Rated frequency limits	25 Hz ... 400 Hz			25 Hz ... 400 Hz			25 Hz ... 400 Hz				25 Hz ... 400 Hz	
Rated operational current $I_e$ / AC-15 according to IEC 60947-5-1												
24-127 V 50/60 Hz	6 A			6 A			6 A				6 A	
220-240 V 50/60 Hz	4 A			4 A			4 A				4 A	
380-440 V 50/60 Hz	3 A			3 A			3 A				3 A	
500 V 50/60 Hz	2 A			2 A			2 A				2 A	
690 V 50/60 Hz	2 A			2 A			2 A				2 A	
Rated operational current $I_e$ / DC-13 according to IEC 60947-5-1												
24 V d.c.	6 A (144 W)			6 A (144 W)			6 A (144 W)				6 A (144 W)	
48 V d.c.	2.8 A (134 W)			2.8 A (134 W)			2.8 A (134 W)				2.8 A (134 W)	
72 V d.c.	2 A (144 W)			2 A (144 W)			2 A (144 W)				2 A (144 W)	
110 V d.c.	1.1 A (121 W)			1.1 A (121 W)			1.1 A (121 W)				1.1 A (121 W)	
125 V d.c.	1.1 A (138 W)			1.1 A (138 W)			1.1 A (138 W)				1.1 A (138 W)	
220 V d.c.	0.55 A (121 W)			0.55 A (121 W)			0.55 A (121 W)				0.55 A (121 W)	
250 V d.c.	0.55 A (138 W)			0.55 A (138 W)			0.55 A (138 W)				0.55 A (138 W)	
Making capacity according to IEC 60947-5-1	10 x $I_e$ / AC-15			10 x $I_e$ / AC-15			10 x $I_e$ / AC-15				10 x $I_e$ / AC-15	
Breaking capacity according to IEC 60947-5-1	10 x $I_e$ / AC-15			10 x $I_e$ / AC-15			10 x $I_e$ / AC-15				10 x $I_e$ / AC-15	
Short-circuit protection gG type fuse	10 A			10 A			10 A				10 A	
Rated short-time withstand current $I_{sw}$ for 1.0 s for 0.1 s	100 A 140 A			100 A 140 A			100 A 140 A				100 A 140 A	
Minimum switching capacity	17 V / 5 mA (1)			17 V / 5 mA (1)			17 V / 5 mA (1)				17 V / 5 mA (1)	
Non-overlapping time between N.O. and N.C. contacts	$\geq 2$ ms			$\geq 2$ ms			$\geq 2$ ms				$\geq 2$ ms	
Heat dissipation per pole at 6 A	0.10 W			0.10 W			0.10 W				0.10 W	

(1) For AL... and AL...Z... contactors, failure rate  $\leq 10^{-7}$  according to IEC 60947-5-4.

#### Utilization Characteristics according to UL/CSA

Contactor	A 9 AL 9 AL 9	A 12 AL 12 AL 12	A 16 AL 16 AL 16	A 26 AL 26 AL 26	A 30 AL 30 AL 30	A 40 AL 40 AL 40	A 45 - -	A 50 - -	A 63 - -	A 75 - -	A 95 - -	A 110 - -
Max. rated voltage	600 V			600 V			600 V				600 V	
Pilot duty	A 600, P 300			A 600, P 300			A 600, P 300				A 600, P 300	



# A..., AL..., AE..., and AF... Contactors Technical Data

## Mounting Characteristics

Contactor	A 9 AL 9 -	A 12 AL 12 -	A 16 AL 16 -	A 26 AL 26 -	A 30 AL 30 -	A 40 AL 40 -	A 45 -	A 50 -	A 63 -	A 75 -	A 95 -	A 110 -
	-	-	-	-	-	-	AE 45 AF 45	AE 50 AF 50	AE 63 AF 63	AE 75 AF 75	AE 95 AF 95	AE 110 AF 110
Mounting positions	see "Conditions for use"											
Mounting distances	The contactors can be assembled side by side											
Fixing												

## Conditions for Use

Sustainable utilization conditions for contactors involving at the same time the Mounting position, Ambient temperature and Control voltage operating limits are summarized in the table below.

Contactor	A 9 AL 9 -	A 12 AL 12 -	A 16 AL 16 -	A 26 AL 26 -	A 30 AL 30 -	A 40 AL 40 -	A 45 -	A 50 -	A 63 -	A 75 -	A 95 -	A 110 -			
	-	-	-	-	-	-	AE 45	AE 50	AE 63	AE 75	AE 95	AE 110			
Control voltage / Ambient temperature															
Mounting positions	≤ 55 °C			0.85 ... 1.1 x U <sub>c</sub>			0.85 ... 1.1 x U <sub>c</sub>			0.85 ... 1.1 x U <sub>c</sub>			0.85 ... 1.1 x U <sub>c</sub>		
1, 2, 3, 4, 5	55 ... 70 °C			U <sub>c</sub>			U <sub>c</sub>			U <sub>c</sub>			0.85 ... 1.1 x U <sub>c</sub>		
Mounting pos. 1 +/- 30°	≤ 55 °C			0.85 ... 1.1 x U <sub>c</sub>			0.85 ... 1.1 x U <sub>c</sub>			0.85 ... 1.1 x U <sub>c</sub>			0.85 ... 1.1 x U <sub>c</sub>		
(unauthorized for AL...Z... types)	55 ... 70 °C			U <sub>c</sub>			U <sub>c</sub>			U <sub>c</sub>			0.85 ... 1.1 x U <sub>c</sub>		
Mounting pos. 6	≤ 55 °C			0.95 ... 1.1 x U <sub>c</sub> (Position 6 unauthorized for AL and AL...Z... types)											
	> 55 °C			unauthorized (Position 6 unauthorized for AL and AL...Z... types)											
Contactor	-	-	-	-	-	-	AF 45	AF 50	AF 63	AF 75	AF 95	AF 110			
Control voltage / Ambient temperature															
Mounting positions	≤ 70 °C						0.85 x U <sub>c</sub> min. ... 1.1 x U <sub>c</sub> max.								
1, 1 + 30°, 2, 3, 4, 5															
Mounting pos. 6							unauthorized						unauthorized		

### Notes for 4-pole contactors

Whatever the coil voltage: Pos. 5 unauthorized for AL 9-22-00, AL 16-22-00, AL 26-22-00, A 45-22-00, AE 45-22-00, AF 45-22-00, A 75-22-00, AE 75-22-00, AF 75-22-00 contactors.

For 60 Hz coil voltage: (only for devices fitted with CA 5-.. and CAL 5-11 auxiliary contacts or TP timer

A 45-40-00, A 50-40-00 and A 75-40-00 contactors

Mounting positions 1 to 5 and ambient temperature < 55 °C: tolerance reduced to 0.9 ... 1.1 U<sub>c</sub> (instead of 0.85 ... 1.1 U<sub>c</sub>) for coil voltage codes 7 and 8.

A 45-22-00 and A 75-22-00 contactors

Mounting positions 1 to 4 and ambient temperature < 55 °C: tolerance reduced to 0.9 ... 1.1 U<sub>c</sub> (instead of 0.85 ... 1.1 U<sub>c</sub>) for coil voltage codes 7 and 8.

For mounting position 6 or ambient temperature of 55 to 70 °C the information given on this page remains applicable.

## Mounting Positions

See the above table for authorized positions

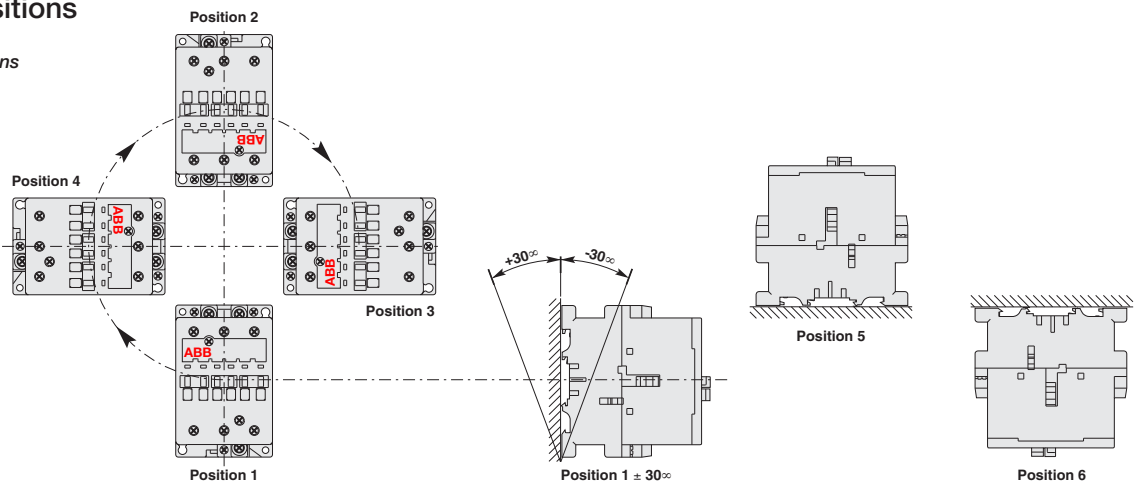

# A... and AF... Contactors Technical Data

## Mounting Characteristics

Contactor	A 145 AF 145	A 185 AF 185	A 210 AF 210	A 260 AF 260	A 300 AF 300	- AF 400	- AF 460	- AF 580	- AF 750	- AF 1350	- AF 1650
Mounting positions	see "Conditions for use"										
Mounting distances	No mounting distance required between contactors										
Fixing on rail	-										
according to IEC 60715, EN 60715 by screws (not supplied)	4 x M5		4 x M5			4 x M5		4 x M6		4 x M8	

## Conditions for Use

Sustainable utilization conditions for contactors involving at the same time the Mounting position, Ambient temperature and Control voltage operating limits are summarized in the table below.

Contactor	A 145	A 185	A 210	A 260	A 300	-	-	-	-	-	-
Control voltage / Ambient temperature Mounting positions 1, 1 + 30°, 2, 3, 4, 5	0.85 ... 1.1 x U <sub>c</sub>					-	-	-	-	-	-
Mounting position 6	unauthorized					-	-	-	-	-	-
Contactor	AF 145	AF 185	AF 210	AF 260	AF 300	AF 400	AF 460	AF 580	AF 750	AF 1350	AF 1650
Control voltage / Ambient temperature Mounting positions 1, 1 + 30°, 2, 3, 4, 5	0.85 ... 1.1 x U <sub>c</sub> min. ... 1.1 x U <sub>c</sub> max.										
Mounting position 6	unauthorized										





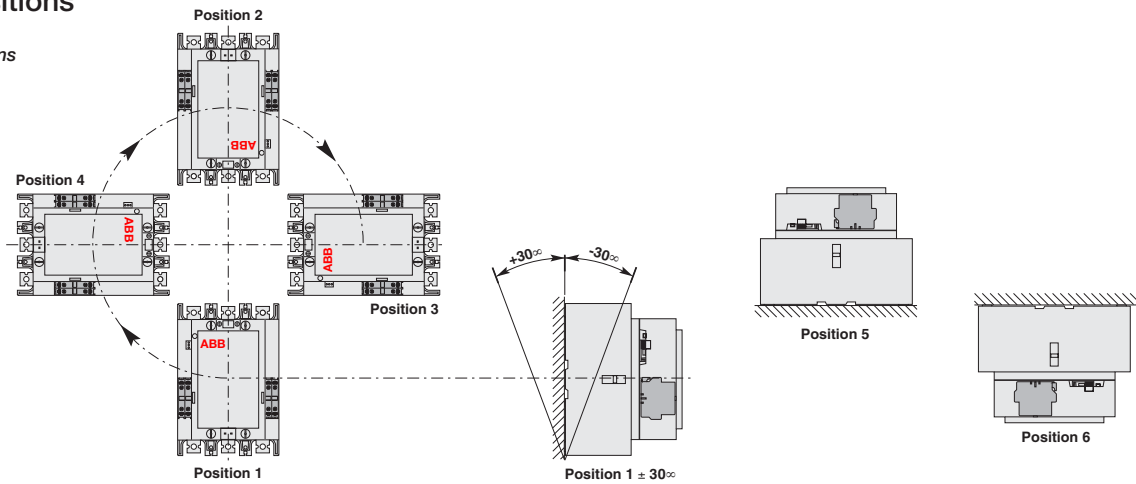





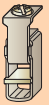





## Mounting Positions

See the above table  
for authorized positions



# A..., AL..., AE..., and AF... Contactors Technical Data

## Connecting Characteristics





Contactor	A 9 AL 9	A 12 AL 12	A 16 AL 16	A 26 AL 26	A 30 AL 30	A 40 AL 40	A 45 - AE 45 AF 45	A 50 - AE 50 AF 50	A 63 - AE 63 AF 63	A 75 - AE 75 AF 75	A 95 - AE 95 AF 95	A 110 - AE 110 AF 110
Main terminals	 with cable clamp			 with double connector 2 x (5.6 x 6.5 mm)			 with single connector (13 x 10 mm)			 with single connector (14 x 14 mm)		
<b>Connecting capacity (min. ... max.)</b>												
<b>Main conductors (poles)</b>												
Rigid: solid ( $\leq 4 \text{ mm}^2$ )	 1 x mm <sup>2</sup>	1 ... 4		1.5 ... 6	2.5 ... 16		6 ... 50				10 ... 95	
stranded ( $\geq 6 \text{ mm}^2$ )	 2 x mm <sup>2</sup>	1 ... 4		1.5 ... 6	2.5 ... 16		6 ... 25				6 ... 35	
Rigid with connector												
single for Cu cable	 mm <sup>2</sup>	-	-	-	-	-	-	-	-	-	-	-
single for Al/Cu cable	 mm <sup>2</sup>	-	-	-	-	-	-	-	-	-	-	-
double for Al/Cu cable	 mm <sup>2</sup>	-	-	-	-	-	-	-	-	-	-	-
Flexible with cable end												
 1 x mm <sup>2</sup>		0.75 ... 2.5		0.75 ... 4	2.5 ... 10		6 ... 35				10 ... 70	
 2 x mm <sup>2</sup>		0.75 ... 2.5		0.75 ... 4	2.5 ... 10		6 ... 16				6 ... 35	
Bars or lugs		L mm $\leq$	7.7	10	-	-	-	-	-	-	30 (2)	
		l mm $\geq$	3.7	4.2	-	-	-	-	-	-	6	
Capacity acc. to UL/CSA (AWG)		10-18		8-12	4-8		1-8				6-2/0	
<b>Auxiliary conductors</b>												
<b>(built-in auxiliary terminals + coil terminals)</b>												
Rigid solid												
 1 x mm <sup>2</sup>		1 ... 4		1 ... 4	1 ... 4		1 ... 4				0.75 ... 2.5	
 2 x mm <sup>2</sup>		1 ... 4		1 ... 4	1 ... 4		1 ... 4				0.75 ... 2.5	
Flexible with cable end												
 1 x mm <sup>2</sup>		0.75 ... 2.5		0.75 ... 2.5	0.75 ... 2.5		1 ... 2.5				0.75 ... 2.5	
 2 x mm <sup>2</sup>		0.75 ... 2.5		0.75 ... 2.5	0.75 ... 2.5		0.75 ... 2.5				0.75 ... 2.5	
Lugs		L mm $\leq$	7.7	(1)	8		8				8	
		l mm $\geq$	3.7	(1)	3.7		3.7				3.7	
Capacity acc. to UL/CSA (AWG)		18-14										
<b>Degree of protection acc. to IEC 60947-1/ EN 60947-1 and IEC 60529 / EN 60529</b>												
Protection against direct contact in acc. with EN 50274												
Main terminals	IP 20			IP 20	IP 20		IP 10				IP 10	
Coil terminals	IP 20			IP 20	IP 20		IP 20				IP 20	
Built-in auxiliary terminals	IP 20			IP 20	IP 20		-	-	-	-	-	-
<b>Screw terminals</b>												
(delivered in open position, screws of unused terminals must be tightened)												
Main terminals	(+/-) pozidriv 2 screws											hexagon socket
	M3.5			M4	M5		M6				M8 (s = 4 mm)	
Coil terminals	M3.5 (+/-) pozidriv 2 screws with cable clamp											
Built-in auxiliary terminals	(+/-) pozidriv 2 screws with cable clamp											
	M3.5			M4	M3.5		-	-	-	-	-	-
<b>Tightening torque</b>												
<b>Main pole terminals</b>												
recommended	Nm/lb. in.	1.00 / 9		1.7 / 15	2.30 / 20		4.00 / 35				6.00 / 53	
max.	Nm	1.20		2.20	2.60		4.50				6.50	
<b>Coil terminals</b>												
recommended	Nm/lb. in.	1.00 / 9		1.00 / 9	1.00 / 9		1.00 / 9				1.00 / 9	
max.	Nm	1.20		1.20	1.20		1.20				1.20	
<b>Built-in auxiliary terminals</b>												
recommended	Nm/lb. in.	1.00 / 9		1.7 / 15	1.00 / 9		-	-	-	-	-	-
max.	Nm	1.20		2.20	1.20		-	-	-	-	-	-

(1)  $L \leq 8$  and  $l > 3.7$  for coil terminals -  $L \leq 10$  and  $l > 4.2$  for built-in auxiliary terminals.

(2) With LW 110 enlargement piece: see "Accessories".

# A... and AF... Contactors Technical Data

## Connecting Characteristics

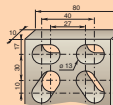
Contactor		A 145 AF 145	A 185 AF 185	A 210 AF 210	A 260 AF 260	A 300 AF 300	- AF 400	- AF 460	- AF 580	- AF 750	- AF 1350	- AF 1650
Main terminals Flat type												
<b>Connecting capacity (min. ... max.)</b>												
Main conductors (poles)												
Rigid:	1 x mm <sup>2</sup>	-	-	-	-	-	-	-	-	-	-	-
	2 x mm <sup>2</sup>	-	-	-	-	-	-	-	-	-	-	-
Rigid with connector												
single for Cu cable	mm <sup>2</sup>	6 ... 185		16 ... 240			240		300		-	-
single for Al/Cu cable	mm <sup>2</sup>	25 ... 150		120 ... 240			240		300		-	-
double for Al/Cu cable	mm <sup>2</sup>	-	-	2 x 95 ... 120			2 x 240		3 x 185		-	-
Flexible	1 x mm <sup>2</sup>	-	-	-	-	-	-	-	-	-	-	-
	2 x mm <sup>2</sup>	-	-	-	-	-	-	-	-	-	-	-
Bars or lugs	L mm ≤	24		32			47		52		100	
	Ø mm >	8		10			10		12		12	
Capacity acc. to UL/CSA (AWG)		6-250 MCM		(2) 4-500 MCM			2/250-500 MCM		3/2/0-500 MCM		1/0-750 MCM	
<b>Auxiliary conductors</b>												
(coil terminals)												
Rigid solid	1 x mm <sup>2</sup>	1 ... 4		1 ... 4			1 ... 4		1 ... 4		1 ... 4	
	2 x mm <sup>2</sup>	1 ... 4		1 ... 4			1 ... 4		1 ... 4		1 ... 4	
Flexible with cable end	1 x mm <sup>2</sup>	0.75 ... 2.5		0.75 ... 2.5			0.75 ... 2.5		0.75 ... 2.5		0.75 ... 2.5	
	2 x mm <sup>2</sup>	0.75 ... 2.5		0.75 ... 2.5			0.75 ... 2.5		0.75 ... 2.5		0.75 ... 2.5	
Lugs	L mm ≤	8		8			8		8		8	
	l mm >	3.7		3.7			3.7		3.7		3.7	
Capacity acc. to UL/CSA (AWG)		18-14		18-14			18-14		18-14		18-14	
<b>Degree of protection acc. to IEC 60947-1/ EN 60947-1 and IEC 60529 / EN 60529</b>												
Protection against direct contact in acc. with EN 50274												
Main terminals		IP 00		IP 00			IP 00		IP 00		IP 00	
Coil terminals		IP 20		IP 20			IP 20		IP 20		IP 20	
Built-in auxiliary terminals		-	-	-	-	-	-	-	-	-	-	-
<b>Screw terminals</b>												
Main terminals												
Screws and bolts												
		M8		M10			M10		M12		M12	
Coil terminals (delivered in open position)		M3.5 (+/-) pozidriv 2 screws with cable clamp										
Built-in auxiliary terminals		-	-	-	-	-	-	-	-	-	-	-
<b>Tightening torque</b>												
Main pole terminals												
recommended	Nm / lb.in	18 / 160		28 / 240			40 / 354		45 / 443		45 / 443	
max.	Nm	20		30			44		49		49	
Coil terminals												
recommended	Nm / lb.in	1.00 / 9		1.00 / 9			1.00 / 9		1.00 / 9		1.00 / 9	
max.	Nm	1.20		1.20			1.20		1.20		1.20	
Built-in auxiliary terminals												
recommended	Nm / lb.in	-	-	-	-	-	-	-	-	-	-	-
max.	Nm	-	-	-	-	-	-	-	-	-	-	-

# Contactors Electrical Durability and Utilization Categories

## General

Utilization categories determine the current making and breaking conditions relating to the characteristics of the loads to be controlled by the contactors. International standard IEC 60947-4-1 and European standard EN 60947-4-1 are the standards to be referred to.

If  $I_c$  is the current to be broken by the contactor and  $I_e$  the rated operational current normally drawn by the load, then:

- Categories AC-1 and AC-3:  $I_c = I_e$
- Category AC-2:  $I_c = 2.5 \times I_e$
- Category AC-4:  $I_c = 6 \times I_e$

Generally speaking  $I_c = m \times I_e$  where  $m$  is a multiple of the load operational current.

On next pages, the curves corresponding to categories AC-1, AC-2, AC-3 and AC-4 represent the electrical durability variation of standard contactors in relation to the breaking current  $I_c$ .

Electrical durability is expressed in millions of operating cycles. For the AC-2 applications, the  $I_e$  values are given in the "stator contactor table" (see "Control of Three-Phase Slip-ring Motors").

## Case of Uninterrupted Duty

Among the different utilization categories, the uninterrupted duty implies the following remark. The combined effect of environmental conditions and the proper temperature of the product may require some disposals. As a matter of fact, for this duty, the use duration prevails over the number of operating cycles.

For long term service, some verifications of preventing maintenance are needed to check the functionality of the concerned product (consult us).

Over a duration of five years, in these conditions the contactor might present high internal resistance. We recommend to change the contactor or change the contacts.

## Curve Utilization Mode

Electrical durability forecast and contactor selection for categories AC-1, AC-2, AC-3 or AC-4.

Note the characteristics of the load to be controlled:

- Operational voltage:  $U_e$
- Current normally drawn:  $I_e$   
 *$U_e / I_e / kW$  relation for motors, see "Motor Rated Operational Powers and Currents".*
- Utilization category: AC-1, AC-2, AC-3 or AC-4
- Breaking current:  $I_c = I_e$  for AC-1 and for AC-3 ;  
 $I_c = 2.5 \times I_e$  for AC-2 ;  $I_c = 6 \times I_e$  for AC-4

Define the number of operating cycles  $N$  required.

On the diagram corresponding to the operational category, select the contactor with the curve immediately above the intersection point ( $I_c ; N$ ).

Electrical durability forecast and contactor selection for mixed duty motor control: AC-3 ( $I_c = I_e$ ) type switching off while "motor running" and, occasionally, AC-4 ( $I_c = 6 \times I_e$ ) type switching off while "motor accelerating".

Note the characteristics of the motor to be controlled:

- Operational voltage:  $U_e$
- Current normally drawn while "motor running":  $I_e$   
 *$U_e / I_e / kW$  relation for motors, see "Motor Rated Operational Powers and Currents".*
- Breaking current for AC-3  $I_c = I_e$
- Breaking current for AC-4 while "motor accelerating":  $I_c = 6 \times I_e$
- Percentage of AC-4 operating cycles  $K$   
*On the basis of the total number of operating cycles.*

Define the total number of operating cycles  $N$  required. Note the smallest contactor rating compatible for AC-3 ( $U_e / I_e$ ) on Main Pole Utilization Characteristic table. See "Technical Data"

For the selected contactor make a note of the following in relation to the voltage using diagram AC-3 in next pages.

- The number of operating cycles:  $A$  for  $I_c = I_e$  (AC-3)
- The number of operating cycles:  $B$  for  $I_c = 6 \times I_e$  (AC-4)

Calculate the estimated number of cycles  $N'$  ( $N'$  is always below  $A$ )

$$N' = \frac{A}{1 + 0.01 K (A/B - 1)}$$

If  $N'$  is too low in relation to the target  $N$ , calculate the estimated number of cycles for a higher contactor rating.

## A... Contactors Electrical Durability

### Electrical Durability for AC-1 Utilization Category

$U_e \leq 690 \text{ V}$  - Ambient Temperature  $\leq 55 \text{ }^\circ\text{C}$

Switching non-inductive or slightly inductive loads. The breaking current  $I_c$  for AC-1 is equal to the rated operational current of the load. Maximum electrical switching frequency: see "Technical Data".

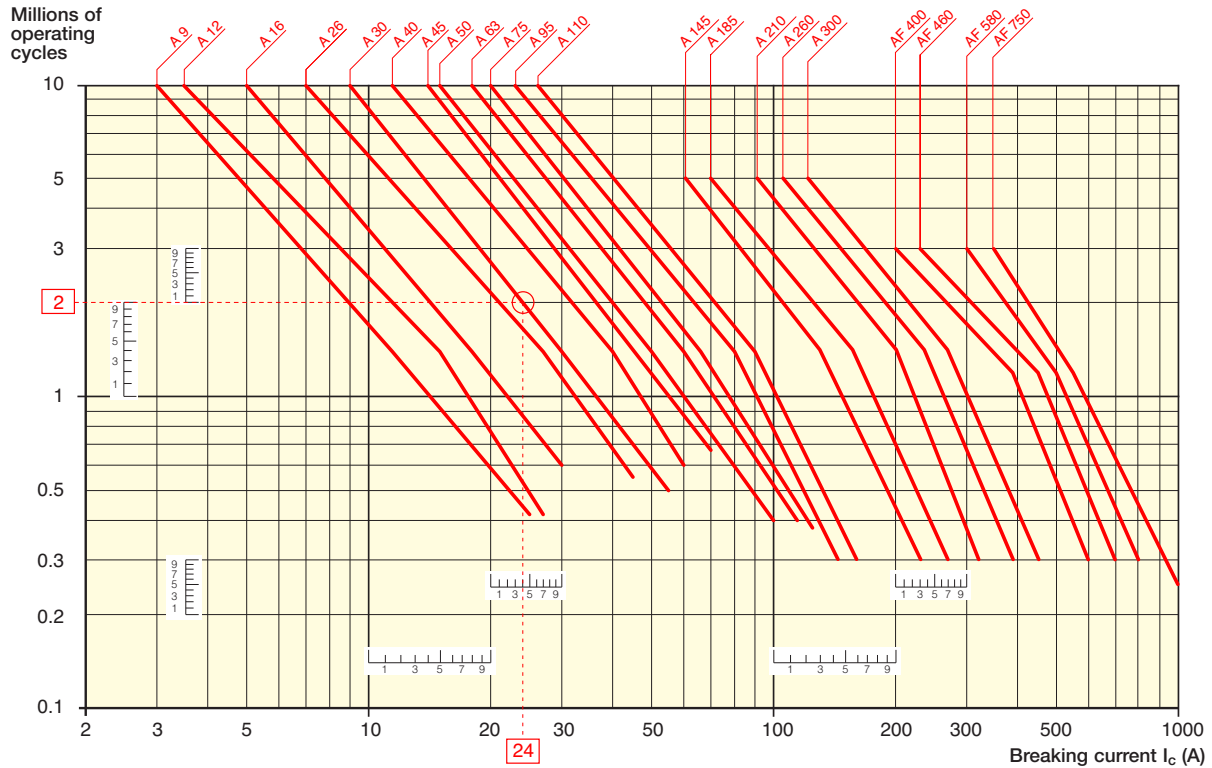

Example:  $I_c / \text{AC-1} = 24 \text{ A}$  - Electrical durability required = 2 million operating cycles.  
Using the AC-1 curves above select the A 30 contactor at intersection "○" (24 A / 2 million operating cycles).

## A... Contactors Electrical Durability

Switching cage motors: starting and switching off running motors. The breaking current  $I_c$  for AC-3 is equal to the rated operational current  $I_e$  ( $I_e$  = motor full load current). Maximum electrical switching frequency: see "Technical Data".

### Electrical Durability for AC-3 Utilization Category - $U_e \leq 440$ V - Ambient Temperature $\leq 55$ °C

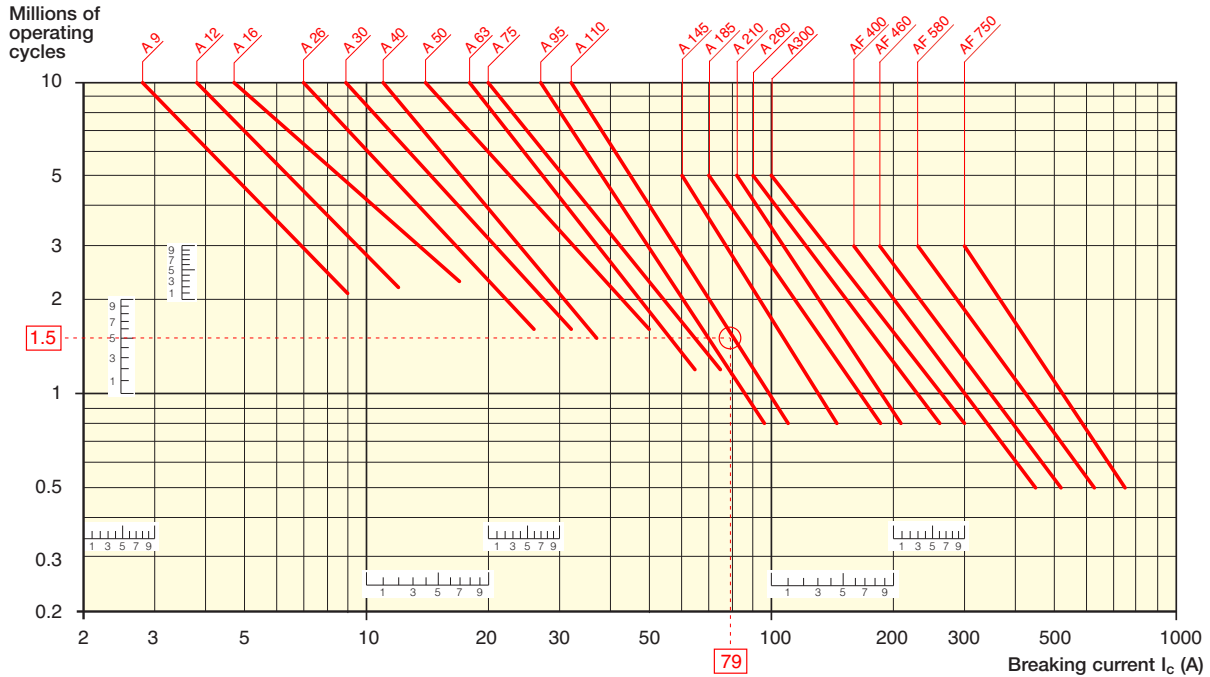

### Electrical Durability for AC-3 Utilization Category - $440 < U_e \leq 690$ V - Ambient Temperature $\leq 55$ °C

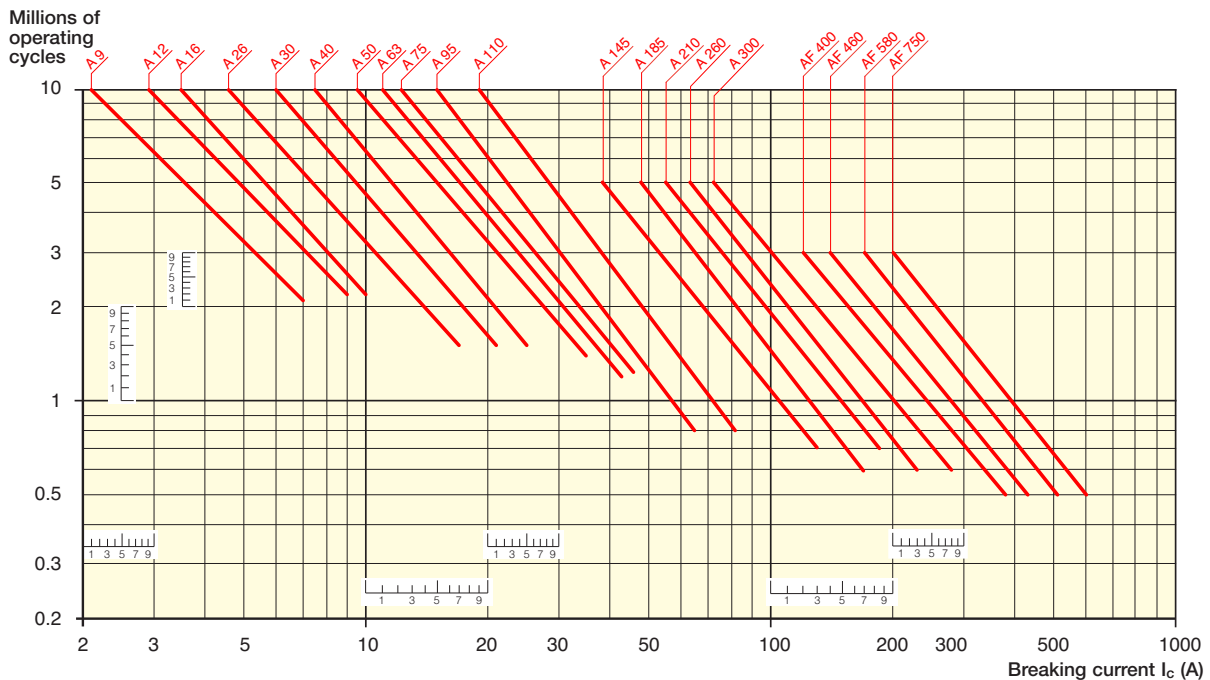

Example: Motor power 40 kW for AC-3 -  $U_e = 400$  V and  $I_e = 79$  A utilization

Electrical durability required = 1.5 million operating cycles.

For AC-3:  $I_c = I_e$ . Select the A 110 contactor at intersection "○" (79 A / 1.5 million operating cycles) on the curves (AC-3 -  $U_e \leq 440$  V).

## A... Contactors Electrical Durability

### Electrical Durability for AC-2 or AC-4 Utilization Category

$U_e \leq 440 \text{ V}$  - Ambient Temperature  $\leq 55 \text{ }^\circ\text{C}$

Switching cage motors: starting, reverse operation and step-by-step operation. The breaking current  $I_c$  is equal to  $2.5 \times I_e$  for AC-2 and  $6 \times I_e$  for AC-4, keeping in mind that  $I_e$  is the motor rated operational current ( $I_e$  = motor full-load current).  
Maximum electrical switching frequency: see "Technical Data".

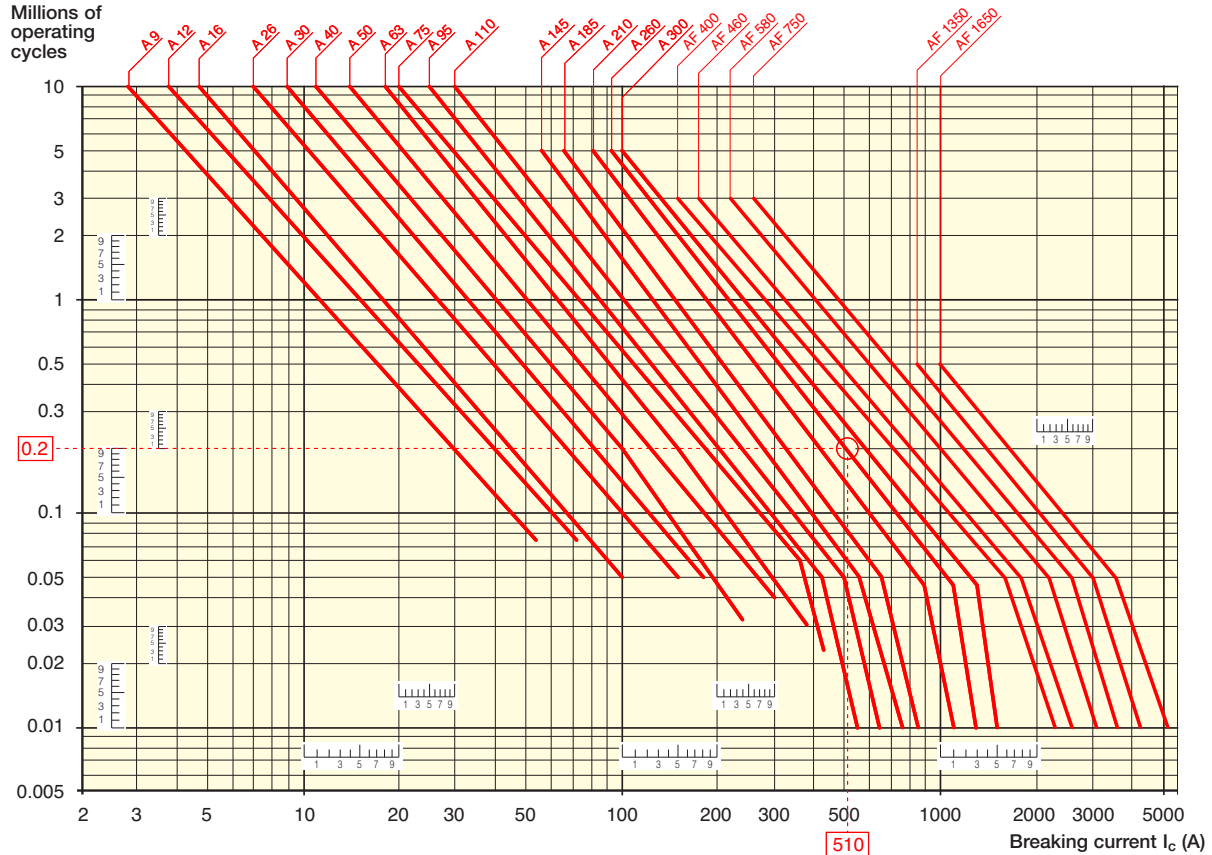

Example: Motor power 45 kW for AC-4 -  $U_e = 400 \text{ V}$  and  $I_e = 85 \text{ A}$  utilization

Electrical durability required = 0.2 million operating cycles.

For AC-4:  $I_c = 6 \times I_e = 510 \text{ A}$  - Select the A 260 contactor at intersection "○" (510 A / 0.2 million operating cycles) on the curves (AC-4 -  $U_e < 440 \text{ V}$ ).



## A... Contactors Electrical Durability

### Electrical Durability for AC-2 or AC-4 Utilization Category $440\text{ V} < U_e \leq 690\text{ V}$ - Ambient Temperature $\leq 55\text{ }^\circ\text{C}$

Switching cage motors: starting, reverse operation and step-by-step operation. The breaking current  $I_c$  is equal to  $2.5 \times I_e$  for AC-2 and  $6 \times I_e$  for AC-4, keeping in mind that  $I_e$  is the motor rated operational current ( $I_e$  = motor full-load current). Maximum electrical switching frequency: see "Technical Data".

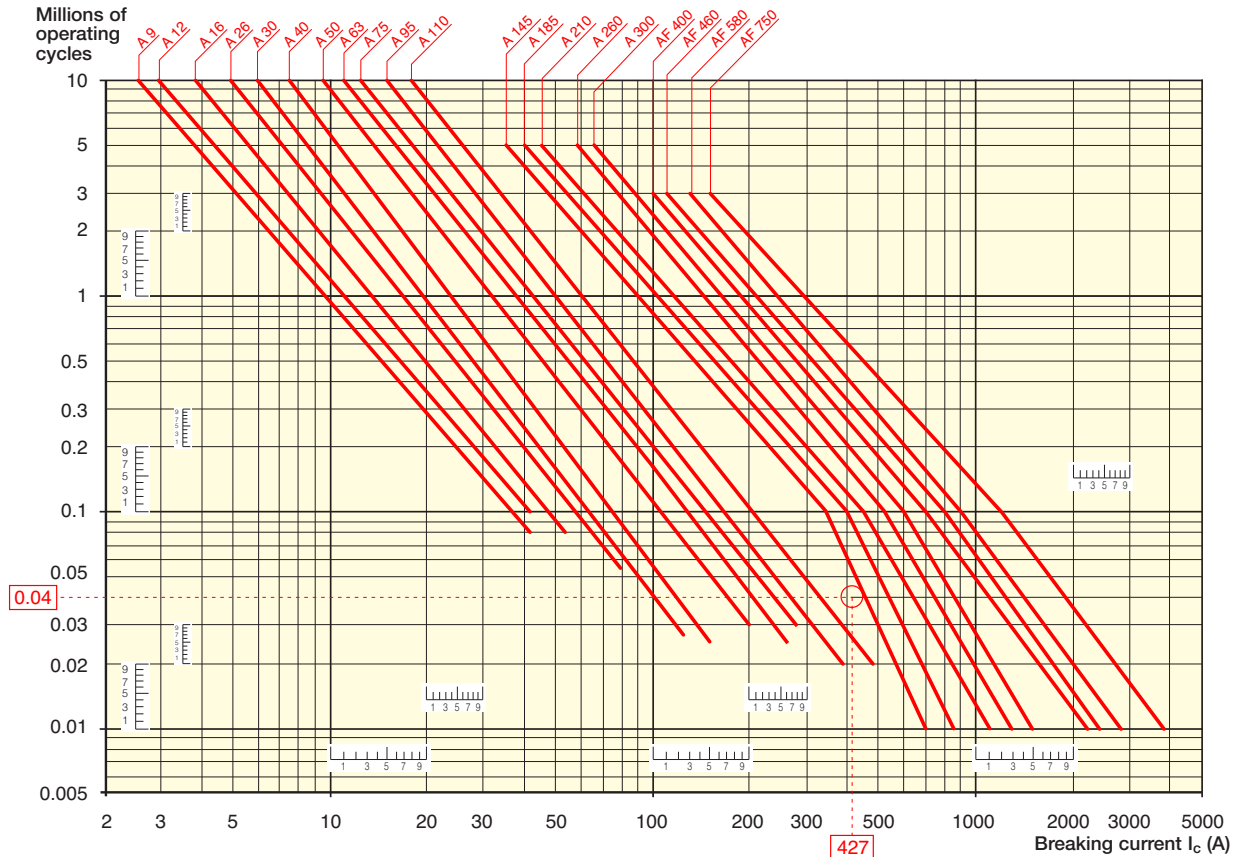

Example: Motor power 59 kW for AC-4 -  $U_e = 600\text{ V}$  and  $I_e = 71.1\text{ A}$  utilization

Electrical durability required = 0.04 million operating cycles.

For AC-4:  $I_c = 6 \times I_e = 426.6\text{ A}$  - Select the A 145 contactor at intersection "○" (427 A / 0.04 million operating cycles) on the curves (AC-4 -  $440\text{ V} < U_e < 690\text{ V}$ ).

## A... Contactors Electrical Durability

### Electrical Durability for AC-1 Utilization Category - $U_e \leq 690 \text{ V}$ - Ambient Temperature $\leq 55 \text{ }^\circ\text{C}$

Switching non-inductive or slightly inductive loads. The breaking current  $I_c$  for AC-1 is equal to the rated operational current of the load. Maximum electrical switching frequency: see "Technical Data".

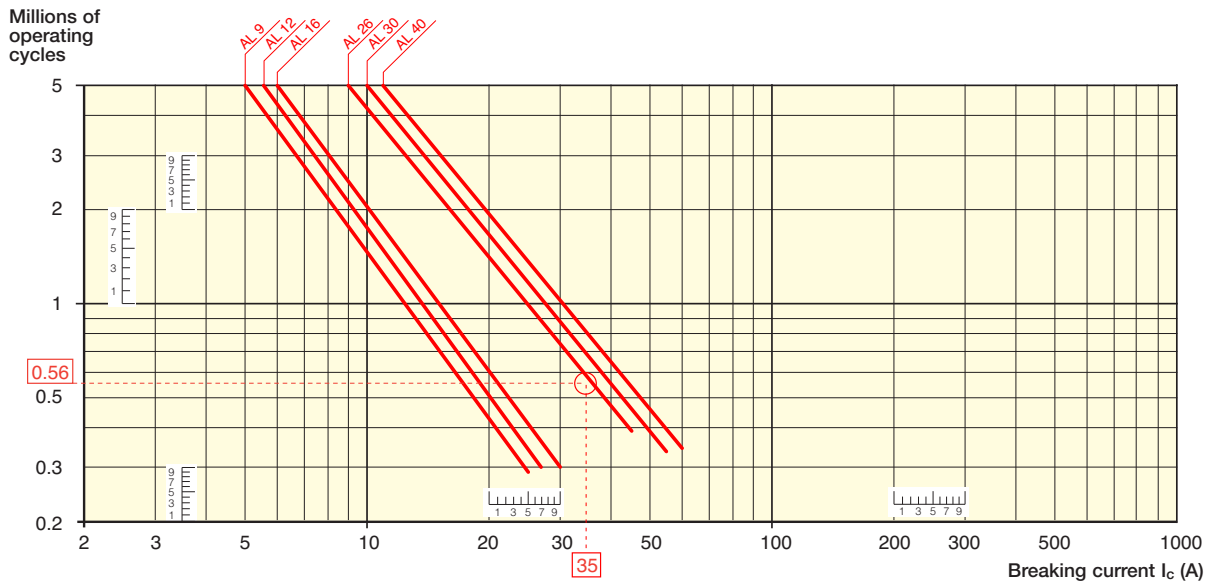

Example:  $I_c / \text{AC-1} = 35 \text{ A}$  – Electrical durability required = 560 000 operating cycles.  
Using the AC-1 curves above select the AL 26 contactor at intersection "○" (35 A / 560 000 operating cycles).

### Electrical Durability for AC-3 Utilization Category $U_e \leq 500 \text{ V}$ - Ambient Temperature $\leq 55 \text{ }^\circ\text{C}$

Switching cage motors: starting and switching off running motors. The breaking current  $I_c$  for AC-3 is equal to the rated operational current  $I_e$  ( $I_e$  = motor full load current). Maximum electrical switching frequency: see "Technical Data".

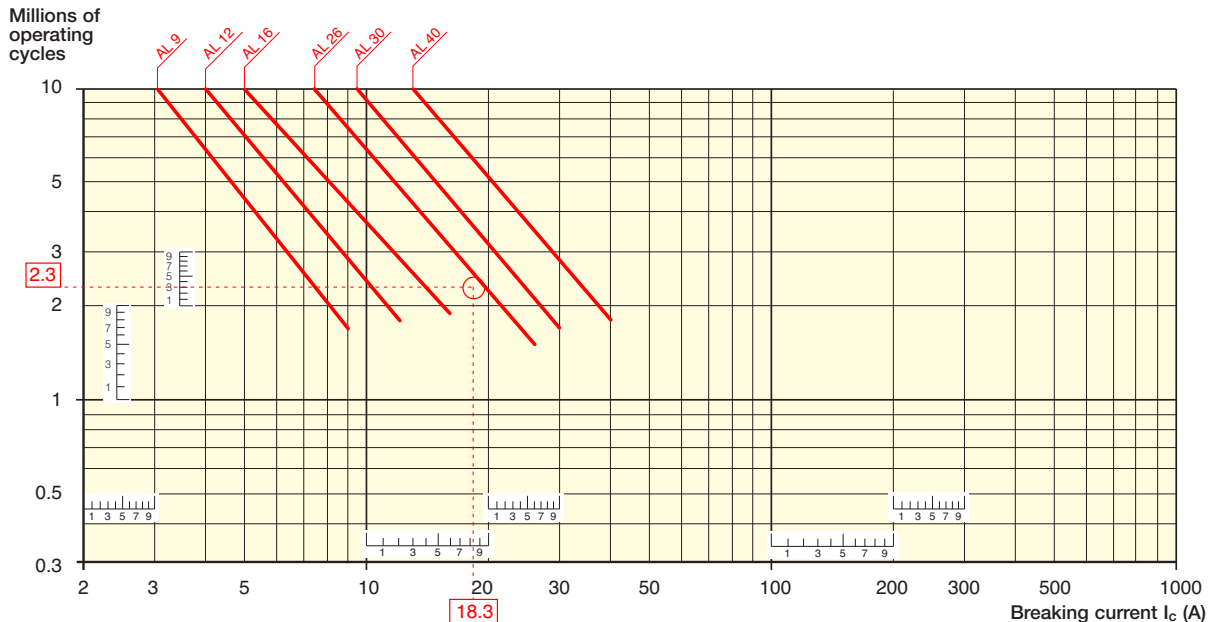

Example: Motor power 9 kW for AC-3 -  $U_e = 400 \text{ V}$  and  $I_e = 18.3 \text{ A}$  utilization – Electrical durability required = 2.3 million operating cycles.  
For AC-3:  $I_c = I_e$ . Select the AL 26 contactor at intersection "○" (18.3 A / 2.3 million operating cycles) on the curves (AC-3 -  $U_e < 500 \text{ V}$ ).

# Influence of the Length of Conductors used in Contactor Control Circuit

Under certain conditions the excessive length of the control circuit conductors may prevent the contactor from carrying out closing and opening orders.

- no closing: due to excessive voltage drop (in a.c. or d.c.)
- no opening: due to excessive capacitance (in a.c.)

## Contactor Closing (contactor with a.c. or d.c. operated coil)

The voltage drop is due to the pull-in current (pull-in power) and to the resistance of the control circuit conductors.

The table at the right and graph below can be used to determine the single length of line feeders (distance between the control device and the contactor coil) in relation to:

- the coil pull-in consumption
- the supply voltage
- the connecting wire cross-sectional area

The graph has been drawn for a maximum line voltage drop of 5%. Coil pull-in consumption (average value).

Contactors	a.c. control circuit - 50 Hz
A 9, 12, 16	70 VA
A 26, 30, 40	120 VA
A 45, 50, 63, 75	180 VA
A 95, 110	450 VA
A 145, 185	700 VA
A 210, 260, 300	1700 VA
AF 45, 50, 63, 75	210 VA
AF 95, 110	350 VA
AF 145, 185	430 VA
AF 210, 260, 300	470 VA
AF 400, 460	890 VA
AF 580, 750	850 VA
AF 1350, 1650	1900 VA

Contactors	d.c. control circuit
AL 9Z, 12Z, 16Z	2.4 W
AL 9, 12, 16	3 W
AL 26, 30, 40	3.5 W
AE 45, 50, 63, 75	200 W
AE 95, 110	400 W
A 210, 260, 300	1700 W
AF 45, 50, 63, 75	190 W
AF 95, 110	400 W
AF 145, 185	500 W
AF 210, 260, 300	520 W
AF 400, 460	990 W
AF 580, 750	950 W
AF 1350, 1650	1700 W

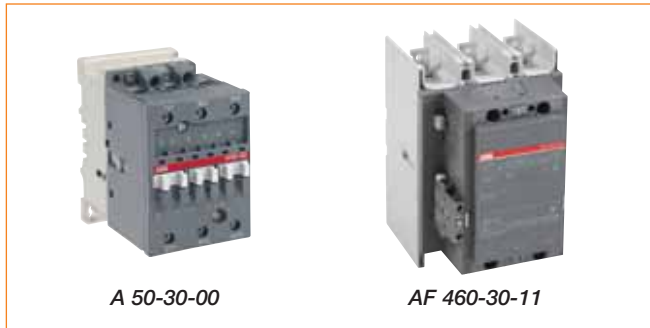

Permissible single length for the control circuit conductors on contactor closing: Depending on the coil pull-in power consumption on the supply voltage and on the control circuit conductor cross-sectional area.

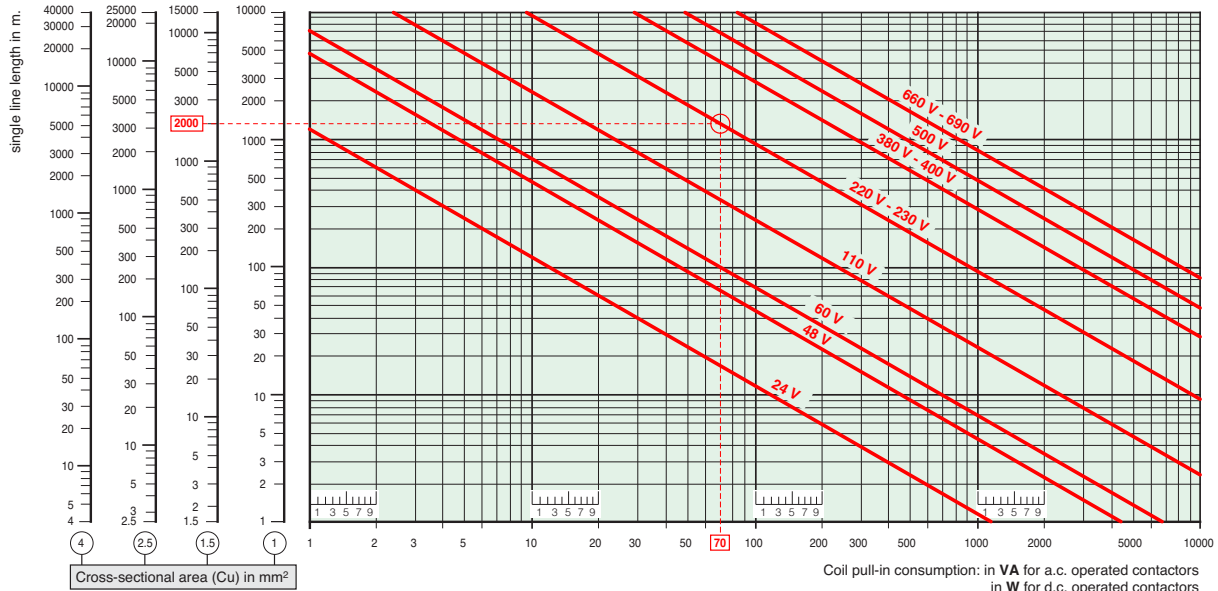

Example: A 9 contactor - Coil voltage: 230 V 50 Hz - Contactor coil pull-in power consumption: 70 VA  
Control circuit conductor cross-sectional area: Cu 1.5 mm<sup>2</sup>. - Max. permissible length: 2000 m.

# Influence of the Length of Conductors used in Contactor Control Circuit

## Contactor Closing (contactor with a.c. operated coil)

Under certain conditions, an a.c. operated contactor does not open when the control circuit is de-energized. This is due to a critical capacity of the excessively long control circuit line and the type of contactor coil control layout. (see diagrams A and B opposite)

This may be caused by the following factors:

- high control voltage
- low coil holding consumption
- low contactor drop-out voltage  
(according to IEC 60947-4-1: 0.2 to 0.75 x U<sub>c</sub>)

If lines longer than those indicated are required, the following measures must be taken:

- select a contactor with a higher rating.
- select a lower control voltage.
- connect "RP" resistance in parallel with the contactor coil:  $R_p = \frac{10^3}{C}$  (with C in  $\mu\text{F}$ )

The table above right and graph below can be used to determine the single length of line feeders (distance between the control device and the contactor coil) in relation to:

- the coil holding consumption VA
- the supply voltage
- the capacity in  $\mu\text{F}/\text{km}$  (depending on the control layout)

Wiring diagrams A and B show two supply and coil control wiring examples. Coil holding consumption (average value).

Contactors	a.c. control circuit - 50 Hz
A 9, 12, 16	8 VA
A 26, 30, 40	12 VA
A 45, 50, 63, 75	18 VA
A 95, 110	22 VA
A 145, 185	35 VA
A 210, 260, 300	60 VA
AF 45, 50, 63, 75	7 VA
AF 95, 110	7 VA
AF 145, 185	12 VA
AF 210, 260, 300	10 VA
AF 400, 460	12 VA
AF 580, 750	12 VA
AF 1350, 1650	48 VA

**Wiring Diagram A**  
Single Control Line Length

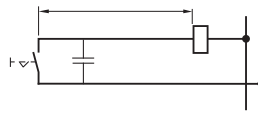

Via maintained pushbutton and 2-core cable (with a capacity of 0.2  $\mu\text{F}/\text{km}$ , for example)

**Wiring Diagram B**  
Single Control Line Length

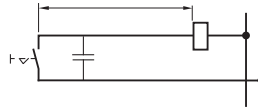

Via momentary pushbutton plus hold-in contact and 3-core cable (with a capacity of  $2 \times 0.2 = 0.4 \mu\text{F}/\text{km}$ , for example)

**Permissible single length for the control circuit conductors on contactor closing: Depending on the coil pull-in power consumption on the supply voltage and on the control circuit conductor cross-sectional area.**

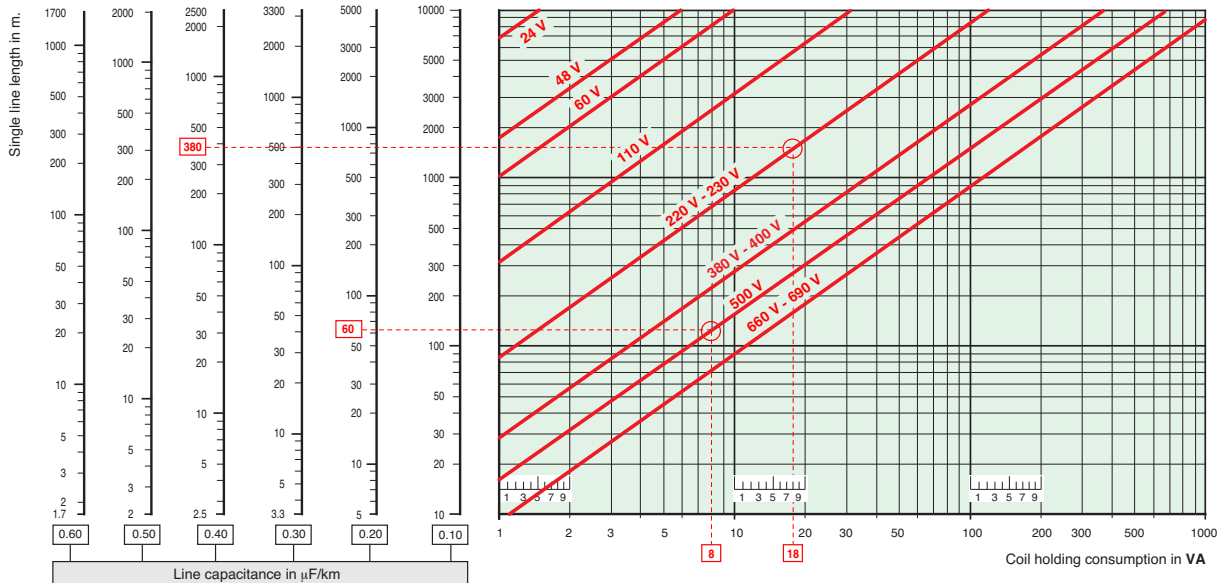

**Example:**

A 16 Contactor

Coil voltage: U<sub>c</sub> = 500 V, 50 Hz, 8 VA contactor coil holding consumption

Control type: diagram A, via maintained pushbutton, and 2-core cable with a capacity of 0.2  $\mu\text{F}/\text{km}$

Max. permissible length: 60 m

A 50 contactor

Coil voltage: U<sub>c</sub> = 230 V, 50 Hz, 18 VA contactor coil holding consumption  
Control type: diagram B via momentary pushbutton, hold-in contact and 3-core cable with a capacity of  $2 \times 0.2 \mu\text{F}/\text{km} = 0.4 \mu\text{F}/\text{km}$   
Max. permissible length: 380 m

# Notes

This document and any attachments may include suggested specifications, drawings, schematics and similar materials from ABB Inc. Use of such information and/or documentation by the recipient is subject to and conditioned upon your acceptance of the terms of the General Document Disclaimer which can be found at [www.jokabsafetyna.com](http://www.jokabsafetyna.com). Your acceptance of the terms of such General Document Disclaimer is conclusively presumed unless you notify ABB in writing of your disagreement with the terms of such Disclaimer immediately upon receipt of this document and you return to ABB all specifications, drawings, schematics and similar materials provided to you by ABB.

# Notes

# Contactors Relays

Choice of 4-pole (1-stack) or 8-pole (2-stack)!  
 Auxiliary contacts for safety circuits available!  
 Wide range of accessories available!

N... Contactor Relays	
a.c. operated .....	15:2
How to Order.....	15:4
Accessory Fitting Details.....	15:5
NL... Contactor Relays	
d.c. operated .....	15:6
How to Order.....	15:8
Accessory Fitting Details.....	15:9
N... and NL... Contactor Relays	
Technical Data.....	15:10
Mounting Positions .....	15:12
Auxiliary Contacts for Safety Circuits.....	15:13



# N... Contactor Relays a.c. operated

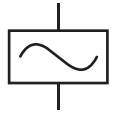

## Applications

Used for switching auxiliary circuits and control circuits.

## Features

- 1-stack contactor relays (4-pole) or 2-stack contactor relays (8-pole)
- mechanically linked contact elements available
- a.c. operated control circuit with laminated magnet circuit
- wide range of accessories available

## Variants

- d.c. operated: NL... contactor relays with low consumption coil



Width of 8-pole devices is identical to that of 4-pole devices. Only the depth is increased.

Location of side mounted accessories (on right or left hand side)

Location of surge suppressors

Quick fixing on mounting rail according to IEC 60715/EN 60715 standards: 35 x 7.5 mm or 35 x 15 mm

Clear marking of coil voltages and respective A1/A2 connection terminals

Holes for screw fixing (screws not supplied)

Terminal marking according to IEC 60947-5-1 and EN 50011

Terminals delivered in open position with captive screws

Screwdriver guidance for all terminals

Degree of protection of terminals according to IEC 60947-1: IP20 for all terminals

Location of function marker

Stops for attaching front mounted accessories

Terminal screws: Pozidriv (+/-) No. 2

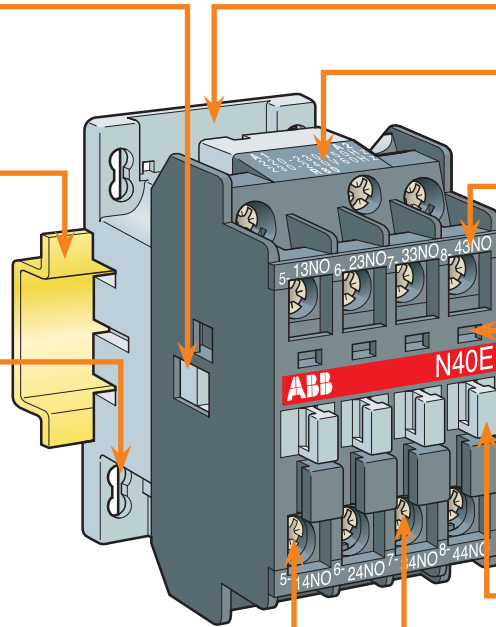



## N... Contactor Relays

a.c. operated

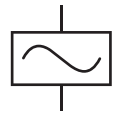

### 4-Pole, 1-Stack (main contacts N.O. + N.C.)

	Diagram	IEC Rated Operational Current					UL/CSA Pilot Duty
		AC-15 240 V	AC-15 400 V	AC-15 690 V	DC-13 24 V	DC-13 250 V	
N22E-		4A	3A	2A	6A / 144W	0.3A / 75W	A 600, Q 300
N31E-		4A	3A	2A	6A / 144W	0.3A / 75W	A 600, Q 300
Main Accessories		Auxiliary Contacts			Surge Suppressors		
	Front Mounting	Side Mounting		(see table below)			
N22E-	CA5-10 (1 N.O.)	CAL5-11 (1 N.O. + 1 N.C.)		RV5/□□□□ / RC5-1/□□□□			
N31E-	CA5-01 (1 N.C.)	CAL5-11 (1 N.O. + 1 N.C.)		RV5/□□□□ / RC5-1/□□□□			

### 8-Pole, 2-Stack (main contacts N.O. + N.C.)

	Diagram	IEC Rated Operational Current					UL/CSA Pilot Duty
		AC-15 240 V	AC-15 400 V	AC-15 690 V	DC-13 24 V	DC-13 250 V	
N44E-		4A	3A	2A	6A / 144W	0.3A / 75W	A 600, Q 300
N53E-		4A	3A	2A	6A / 144W	0.3A / 75W	A 600, Q 300
N62E-		4A	3A	2A	6A / 144W	0.3A / 75W	A 600, Q 300
N71E-		4A	3A	2A	6A / 144W	0.3A / 75W	A 600, Q 300
Main Accessories		Auxiliary Contacts			Surge Suppressors		
		Side Mounting		(see table below)			
N44E-		CAL5-11 (1 N.O. + 1 N.C.)		RV5/□□□□ / RC5-1/□□□□			
N53E-		CAL5-11 (1 N.O. + 1 N.C.)		RV5/□□□□ / RC5-1/□□□□			
N62E-		CAL5-11 (1 N.O. + 1 N.C.)		RV5/□□□□ / RC5-1/□□□□			
N71E-		CAL5-11 (1 N.O. + 1 N.C.)		RV5/□□□□ / RC5-1/□□□□			

### Surge Suppressors

Feature	Voltage Range	Part Number
Varistor	24 - 50 VAC/DC	RV5/50
	50 - 133 VAC/DC	RV5/133
	110 - 250 VAC/DC	RV5/250
	250 - 440 VAC/DC	RV5/440
RC	24 - 50 VAC	RC5-1/50
	50 - 133 VAC	RC5-1/133
	110 - 250 VAC	RC5-1/250
	250 - 440 VAC	RC5-1/440

## N... Contactor Relays

a.c. operated

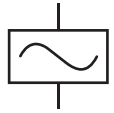

### HOW TO ORDER

Number of Contacts  
1st stack 2nd stack



Part Number  
state coil voltage  
code

(see table below)

Packing Quantity: 1 pc

### 4-Pole, 1-Stack



1st Stack	2nd Stack	Part Number	Weight
2 2	— —	N22E- <input type="text"/> <input type="text"/>	0.750 lb (0.340 kg)
3 1	— —	N31E- <input type="text"/> <input type="text"/>	0.750 lb (0.340 kg)

### 8-Pole, 2-Stack



1st Stack	2nd Stack	Part Number	Weight
4 —	— 4	N44E- <input type="text"/> <input type="text"/>	0.882 lb (0.400 kg)
4 —	1 3	N53E- <input type="text"/> <input type="text"/>	0.882 lb (0.400 kg)
4 —	2 2	N62E- <input type="text"/> <input type="text"/>	0.882 lb (0.400 kg)
4 —	3 1	N71E- <input type="text"/> <input type="text"/>	0.882 lb (0.400 kg)

### Coil Voltages and Codes

Voltage V - 50Hz	Voltage V - 60Hz	Code <input type="text"/> <input type="text"/>
24	24	8 1
48	48	8 3
110	110 - 120	8 4
220 - 230	230 - 240	8 0
230 - 240	240 - 260	8 8
380 - 400	400 - 415	8 5
400 - 415	415 - 440	8 6

## Accessory Fitting Details N... Contactor Relays

a.c. operated

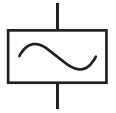

Many configurations of accessories are possible depending on whether these are front mounted or side mounted.

Contactor	Built-In Contacts		Front Mounted Accessories			Side Mounted Accessories
	1st Stack	2nd Stack	Auxiliary Contact 1-pole CA5-...		Auxiliary Contact 4-pole CA5-...	Auxiliary Contact 2-pole CAL5-11
N22E- (1)	2 2	— —	1 to 4 x CA5-...	or	1 x CA5-...	1 to 2 x CAL5-11 (4-pole)
N31E- (1)	3 1	— —	1 to 4 x CA5-...	or	1 x CA5-... (4-pole)	1 to 2 x CAL5-11
N44E-	4 0	0 4	n/a		n/a	1 to 2 x CAL5-11
N53E-	4 0	1 3	n/a		n/a	1 to 2 x CAL5-11
N62E-	4 0	2 2	n/a		n/a	1 to 2 x CAL5-11
N71E-	4 0	3 1	n/a		n/a	1 to 2 x CAL5-11

(1) 2 x N.C. front mounted auxiliary contacts maximum in mounting position 5. N22E- and N31E- in mounting position 5, TP...DA not allowed.

(2) Additional N.C. CA5-... auxiliary contacts are limited to 2.

## N... Contactor Relays and Main Accessories

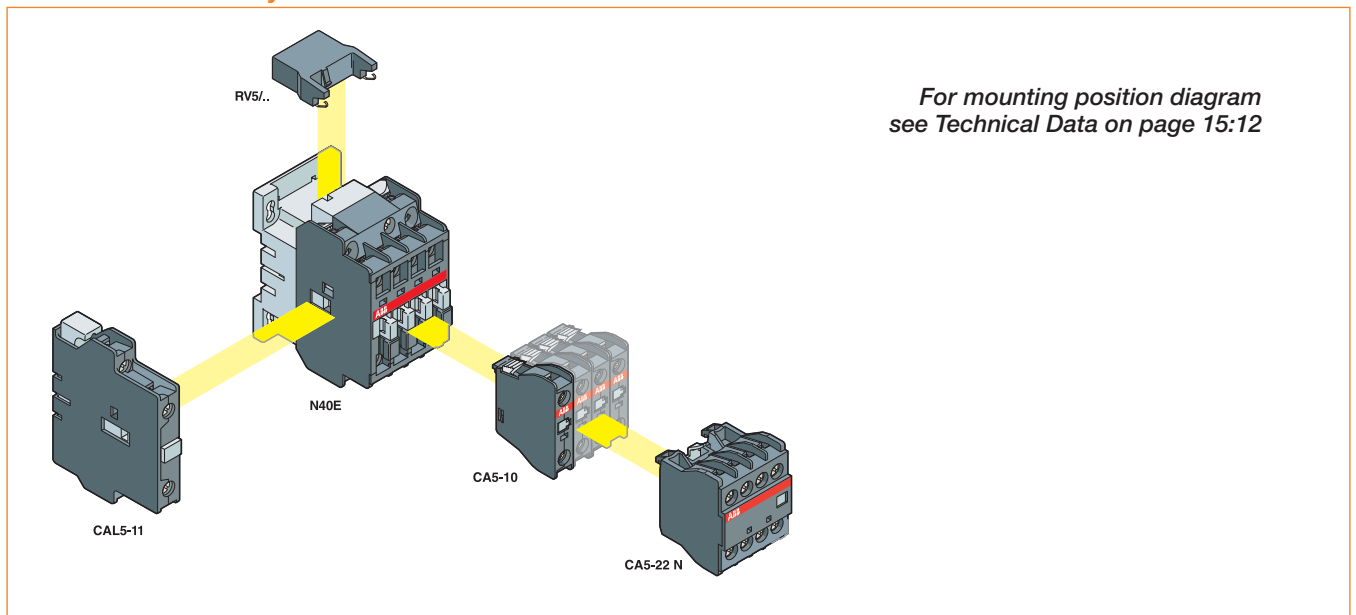

# NL... Contactor Relays d.c. operated

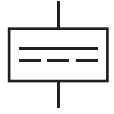

## Applications

Used for switching auxiliary circuits and control circuits. Their low power consumption allows the direct control from transistor PLC outputs.

## Features

- 1-stack contactor relays (4-pole) or 2-stack contactor relays (8-pole)
- mechanically linked contact elements available
- d.c. operated control circuit  
*Note: The polarity on the coil terminals (A1+ and A2-) must be respected.*
- NL... contactor relays fitted with low consumption d.c. coils: 3W (Pull-in and holding)
- wide range of accessories available



Width of 8-pole devices is identical to that of 4-pole devices. Only the depth is increased.

Location of side mounted accessories (on right or left hand side)

Location of surge suppressors

Quick fixing on mounting rail according to IEC 60715/EN 60715 standards: 35 x 7.5 mm or 35 x 15 mm

Clear marking of coil voltages and respective A1/A2 connection terminals

Holes for screw fixing (screws not supplied)

Terminal marking according to IEC 60947-5-1 and EN 50011

Terminals delivered in open position with captive screws

Screwdriver guidance for all terminals

Degree of protection of terminals according to IEC 60947-1: IP20 for all terminals

Location of function marker

Stops for attaching front mounted accessories

Terminal screws: Pozidriv (+/-) No.2

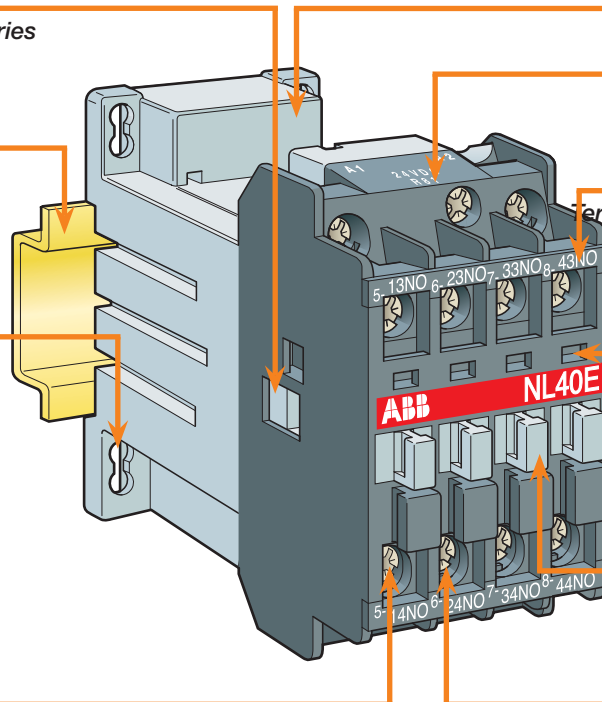

## NL... Contactor Relays

d.c. operated

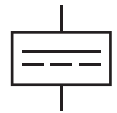

### 4-Pole, 1-Stack (main contacts N.O. + N.C.)

	Diagram	IEC Rated Operational Current					UL/CSA Pilot Duty
		AC-15 240 V	AC-15 400 V	AC-15 690 V	DC-13 24 V	DC-13 250 V	
NL22E-		4A	3A	2A	6A / 144W	0.3A / 75W	A 600, Q 300
NL31E-		4A	3A	2A	6A / 144W	0.3A / 75W	A 600, Q 300
Main Accessories		Auxiliary Contacts			Surge Suppressors		
	Front Mounting	Side Mounting		(see table below)			
NL22E-	CA5-10 (1 N.O.)	CAL5-11 (1 N.O. + 1 N.C.)		RV5/□□□□ / RT5/□□□□			
NL31E-	CA5-01 (1 N.C.)	CAL5-11 (1 N.O. + 1 N.C.)		RV5/□□□□ / RT5/□□□□			



### 8-Pole, 2-Stack (main contacts N.O. + N.C.)

	Diagram	IEC Rated Operational Current					UL/CSA Pilot Duty
		AC-15 240 V	AC-15 400 V	AC-15 690 V	DC-13 24 V	DC-13 250 V	
NL44E-		4A	3A	2A	6A / 144W	0.3A / 75W	A 600, Q 300
NL53E-		4A	3A	2A	6A / 144W	0.3A / 75W	A 600, Q 300
NL62E-		4A	3A	2A	6A / 144W	0.3A / 75W	A 600, Q 300
NL71E-		4A	3A	2A	6A / 144W	0.3A / 75W	A 600, Q 300
Main Accessories		Surge Suppressors					
		(see table below)					
NL44E-		RV5/□□□□ / RT5/□□□□					
NL53E-		RV5/□□□□ / RT5/□□□□					
NL62E-		RV5/□□□□ / RT5/□□□□					
NL71E-		RV5/□□□□ / RT5/□□□□					



### Surge Suppressors

Feature	Voltage Range	Part Number
Varistor	24 - 50 VAC/DC	RV5/50
	50 - 133 VAC/DC	RV5/133
	110 - 250 VAC/DC	RV5/250
	250 - 440 VAC/DC	RV5/440
Transil Diode	12 - 32 VDC	RT5/32
	25 - 65 VDC	RT5/65
	50 - 90 VDC	RT5/90
	77 - 150 VDC	RT5/150
	150 - 264 VDC	RT5/264

## NL... Contactor Relays

d.c. operated

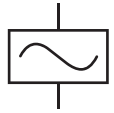

### HOW TO ORDER

Number of Contacts  
1st stack 2nd stack



Part Number  
state coil voltage  
code □□

(see table below)

Packing Quantity: 1 pc

### 4-Pole, 1-Stack



1st Stack		2nd Stack		Part Number	Weight
2	2	—	—	NL22E-□□	1.146 lb (0.520 kg)
3	1	—	—	NL31E-□□	1.146 lb (0.520 kg)

### 8-Pole, 2-Stack



1st Stack		2nd Stack		Part Number	Weight
4	—	—	4	NL44E-□□	1.279 lb (0.580 kg)
4	—	1	3	NL53E-□□	1.279 lb (0.580 kg)
4	—	2	2	NL62E-□□	1.279 lb (0.580 kg)
4	—	3	1	NL71E-□□	1.279 lb (0.580 kg)

### NL... Coil Voltages and Codes

Voltage VDC	Code □□
12	8 0
24	8 1
42	8 2
48	8 2
50	2 1
60	8 4
75	8 5
110	8 6
125	8 7
220	8 8
240	8 9
250	3 8

## Accessory Fitting Details NL... Contactor Relays

d.c. operated

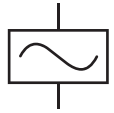

Many configurations of accessories are possible depending on whether these are front mounted or side mounted.

Contactor	Built-In Contacts		Front Mounted Accessories		Side Mounted Accessories	
	1st Stack	2nd Stack	Auxiliary Contact 1-pole CA5-...	Auxiliary Contact 4-pole CA5-...	Auxiliary Contact 2-pole CAL 5-11	
NL22E- (4)	2 2	— —	1 to 4 x CA5-... (3)	or	1 x CA5-... (4-pole) (3) +	1 x CAL5-11 (2)
NL31E- (1)	3 1	— —	1 to 4 x CA5-... (3)	or	1 x CA5-... (4-pole) (1) +	1 x CAL5-11 (2)
NL44E-	4 0	0 4	n/a		n/a	n/a
NL53E-	4 0	1 3	n/a		n/a	n/a
NL62E-	4 0	2 2	n/a		n/a	n/a
NL71E-	4 0	3 1	n/a		n/a	n/a

(1) A maximum of 2 N.C. auxiliary contacts can be fitted in all mounting positions except 5. In position 5 no N.C. auxiliary contacts are permitted.

(2) With CAL5-11 the control voltage is limited to  $0.9 U_c - 1.1 U_c$  in all mounting positions.

(3) A maximum of 2 N.C. auxiliary contacts can be fitted.

(4) Mounting position 5 is not allowed.

### NL... Contactor Relays and Main Accessories

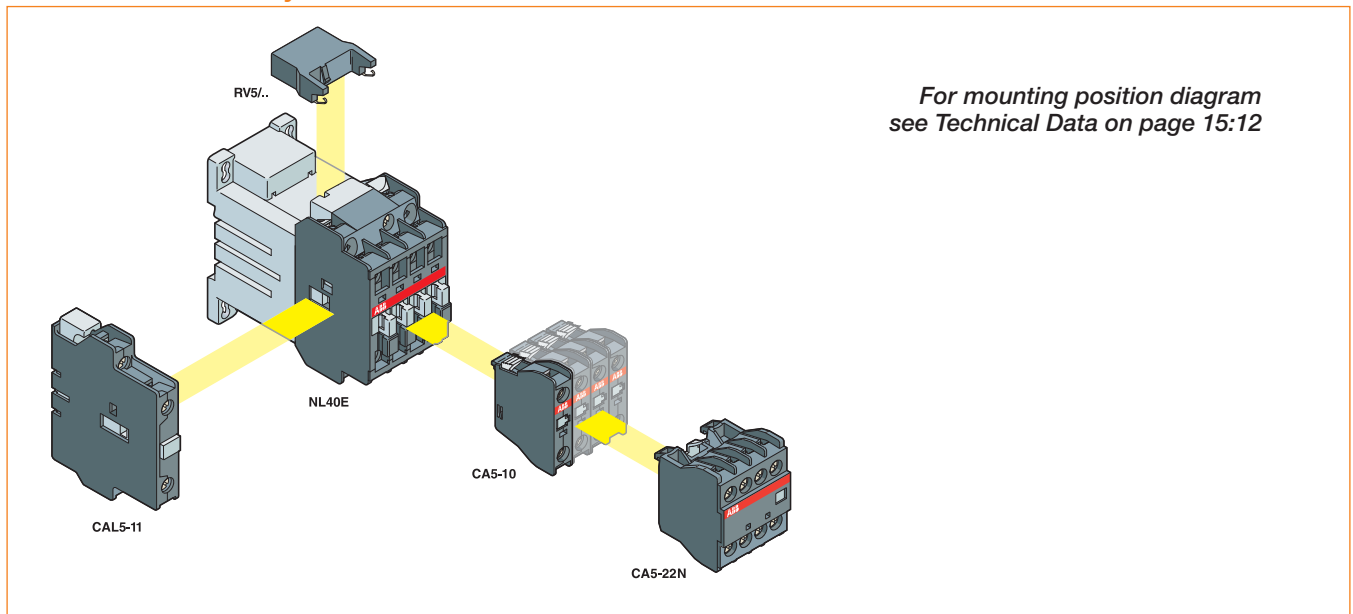

## N... and NL... Contactor Relays Technical Data

Manufacturer	ABB
Ordering Information	see pages 15.4 and 15:8
Utilization Characteristics	(according to IEC)
Rated Operational Voltage $U_e$ max	690 V
Conventional Free Air Thermal Current $I_{th}$	16 A (according to IEC 60947-5-1, open contactors $\theta \leq 40^\circ \text{C}$ )
Rated Frequency Limits	25-400 Hz
Rated Operational Current $I_e$ /AC-15	
24-127 V, 50/60 Hz	6 A (according to IEC 60947-5-1)
230-240 V, 50/60 Hz	4 A (according to IEC 60947-5-1)
400-415 V, 50/60 Hz	3 A (according to IEC 60947-5-1)
500 V, 50/60 Hz	2 A (according to IEC 60947-5-1)
690 V, 50/60 Hz	2 A (according to IEC 60947-5-1)
Rated Operational Current $I_e$ /DC-13	
24 V DC	6 A/144 W (according to IEC 60947-5-1)
48 V DC	2.8 A/134 W (according to IEC 60947-5-1)
72 V DC	1 A/72 W (according to IEC 60947-5-1)
110 V DC	.55 A/60 W (according to IEC 60947-5-1)
125 V DC	.55 A/69 W (according to IEC 60947-5-1)
220 V DC	.30 A/66 W (according to IEC 60947-5-1)
250 V DC	.30 A/75 W (according to IEC 60947-5-1)
Making Capacity	$10 \times I_e$ /AC-15 (according to IEC 60947-5-1)
Breaking Capacity	$10 \times I_e$ /AC-15 (according to IEC 60947-5-1)
Short Circuit Protection $U_e \leq 500 \text{ V AC}$ - gG type fuse	10 A
Rated Short-Time Withstand Current $I_{cw}$	
1.0 s	100 A
0.1 s	140 A
	(at $40^\circ \text{C}$ ambient temperature, in free air, from a cold state)
Minimum Switching Capacity	17 V / 5 mA
with failure rate - N	$\leq 10^{-6}$
with failure rate - NL	$\leq 10^{-7}$
	(according to IEC 60947-5-4)
Non-Overlapping Time between N.O. and N.C. Contacts	$\leq 2 \text{ ms}$
Heat Dissipation per Pole at 6 A	0.10 W
Maximum Electric Switching Frequency	1200 cycles/h
Mechanical Durability	
millions of operating cycles	> 20
max mechanical switching frequency	6000 cycles/h
Utilization Characteristics According to UL/CSA	
Rated Operational Voltage	600 V
Pilot Duty	A 600, Q 300

General Technical Data	
Rated Insulation Voltage $U_i$ according to IEC 60947-5-1 according to UL/CSA	690 V 600 V
Rated Impulse Withstand Voltage $U_{imp}$	8 kV
Standards	devices complying with IEC 60947-5-1 and EN 60947-5-1
Air Temperature (close to contactor) for operation in free air for storage	-40° C to +70° C -60° C to +80° C (see "Conditions for Use" on page 15:12 for control voltage limits and authorized mounting positions)
Climactic Withstand	according to IEC 60068-2-30 and 60068-2-11 - UTE C 63-100 specification II
Operating Altitude	$\leq 3000 \text{ m}$
Shock Withstand mounting position 1 shock direction A	1/2 sinusoidal shock for 11 ms (no change in contact position)
N... (closed or open position)	20 g
NL... (closed position)	20 g
shock direction B1	
N... (closed or open position)	5 g
NL... (closed position)	15 g
shock direction B2	
N... (closed or open position)	15 g
NL... (closed position)	10 g
shock direction C1	
N... (closed or open position)	20 g
NL... (closed position)	20 g
shock direction C2	
N... (closed or open position)	20 g
NL... (closed position)	14 g

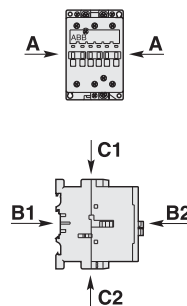

Note: Data at  $T_a = 25^\circ \text{C}$ ,  $U_{IN} = V \text{ AC}$  and rated values, if nothing else indicated.





Magnet System Characteristics for N... Contactor Relays	
Rated Control Circuit Voltage $U_e$ - 50/60 Hz	24-690 V
Coil Operating Limits	0.85-1.1 x $U_c$ ( $\theta \leq 55^\circ C$ ) (according to IEC 60947-5-1, please also refer to "Conditions for Use" on page 15:12)
Drop-Out Voltage in % of $U_e$	approx 40-65%
Coil Consumption average pull-in value	
50 Hz	70 VA
60 Hz	80 VA
50-60 Hz (1)	74-70 VA
average holding value	
50 Hz	8 VA/2 W
60 Hz	8 VA/2 W
50-60 Hz (1)	8 VA/2 W
Operating Time	
between coil energization and N.O. contact closing	10-26 ms
between coil energization and N.C. contact opening	7-21 ms
between coil de-energization and N.O. contact opening	4-11 ms
between coil de-energization and N.C. contact closing	9-16 ms

(1) 50/60 Hz coils: see "Coil Voltage Code Table"

Magnet System Characteristics for NL... Contactor Relays	
Rated Control Circuit Voltage $U_e$	12-250 V DC
Coil Operating Limits	0.85-1.1 x $U_c$ ( $\theta \leq 55^\circ C$ ) (according to IEC 60947-5-1, please also refer to "Conditions for Use" on page 15:12)
Drop-Out Voltage in % of $U_e$	approx 10-30%
Coil Consumption average pull-in value	3.0 W
average holding value	3.0 W
Coil Time constant	
open L/R	28 ms
closed L/R	74 ms
Operating Time	
between coil energization and N.O. contact closing	50-100 ms
between coil energization and N.C. contact opening	20-70 ms
between coil de-energization and N.O. contact opening	10-17 ms (2)
between coil de-energization and N.C. contact closing	16-27 ms (2)

(2) The use of surge suppressors increases the opening time with a factor of 1.1 to 1.5 for a varistor suppressor and a factor of 1.5 to 3 for a transil diode suppressor.

## N... and NL... Contactor Relays Technical Data (continued)







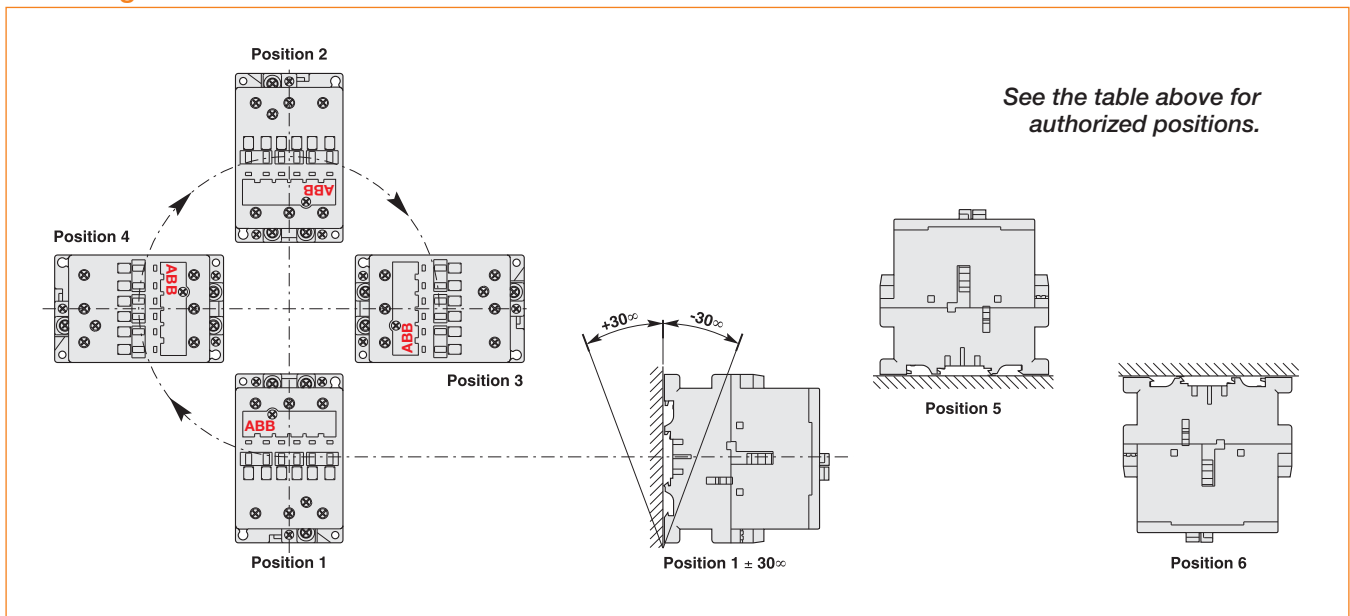

Mounting Characteristics	
Mounting Positions	refer to "Conditions for Use" below
Mounting Distances	no mounting distance required between contactors
Drop-Out Voltage in % of $U_e$	approx 40-65%
Fixing	
on rail	 35 x 7.5 mm
according to IEC 60715 and EN 60715	 35 x 15 mm
by screws (not supplied)	2 x M4
Conditions for Use	
Sustainable utilization conditions for contactor relays—involving at the same time the Mounting Position, Ambient Temperature and Control Voltage operating limits—are summarized in the table at the right.	

Control Voltage/Ambient Temperature	
Mounting Positions for N... Contactor Relays	
$\leq 55^\circ\text{C}$	$0.85-1.1 \times U_c$
$55^\circ-70^\circ\text{C}$ - 1, 2, 3, 4, 5 (1)	$U_c$
$\leq 55^\circ\text{C}$	$0.85-1.1 \times U_c$
1 +/- $30^\circ$ - $55^\circ-70^\circ\text{C}$	$U_c$
$\leq 55^\circ\text{C}$	$0.95-1.1 \times U_c$
6	unauthorized 3.0 W
Mounting Positions for NL... Contactor Relays	
$\leq 55^\circ\text{C}$	$0.85-1.1 \times U_c$
$55^\circ-70^\circ\text{C}$ - 1, 2, 3, 4, 5 (1)	$U_c$
$\leq 55^\circ\text{C}$	$0.85-1.1 \times U_c$
1 +/- $30^\circ$ - $55^\circ-70^\circ\text{C}$	$U_c$
$\leq 55^\circ\text{C}$	unauthorized
6	unauthorized

(1) NL22E- are not allowed in position 5.

### Mounting Positions



Connecting Characteristics	
Terminals	 with cable clamp
Mounting Distances	
Connecting Capacity (min-max)	
Pole and Coil Terminals	
rigid solid  1 x mm <sup>2</sup>	1-4
 2 x mm <sup>2</sup>	1-4
flexible with cable end  1 x mm <sup>2</sup>	0.75-2.5
 2 x mm <sup>2</sup>	0.75-2.5
Lugs	
pole terminals  L mm ≤	7.7
 1 mm >	3.7
coil terminals  L mm ≤	8.0
 1 mm >	3.7

Capacity according to UL/CSA	18-14 AWG
Degree of Protection all terminals (according to IEC 60947-1/EN 60947-1 and IEC 60529/EN 60529)	IP 20 (protection against direct contact in accordance with EN 50274)
Screw Terminals all terminals (delivered in open position)	M 3.5 (+/-) pozidriv 2 screws with cable clamp (screws of unused terminals must be tightened)
Tightening Torque recommended maximum	1.00 Nm/9 lb in 1.20 Nm

## Auxiliary Contacts for Safety Circuits

Definitions from standards:

### Mechanically Linked Contact Elements



(according to IEC 60947-5-1, Annex L 3.0)

Combination of “n” Make auxiliary contact element(s) and “m” Break auxiliary contact element(s) are designed in such a way that they cannot be in the closed position simultaneously.

One control circuit device may have more than one group of mechanically linked contact elements.

### Direct Opening Action of N.C. Built-In Auxiliary Contacts

Annex K2.1 of IEC 60947-5-1 defines a control switch with direct opening action as “the full contact opening of the break contact element(s) is obtained when the actuator is moved through the direct opening travel by applying the force stated by the manufacturer”.

The N.C. built-in auxiliary contacts of contactor relays ARE NOT CONCERNED by the annex K.

Nevertheless, N.C. auxiliary contacts are designed to have “direct opening action” and are suitable for uses such as lifts/elevators, according to EN 81-1).

The table below gives the contactor relays that offer mechanically linked auxiliary contacts

(according to IEC 60947-5-1, Annex L)

Contactor Relay	Built-In Auxiliary Contacts
N22E-, NL22E-	2 2
N31E-, NL31E-	3 1
N44E-, NL44E-	4 4
N53E-, NL53E-	5 3
N62E-, NL62E-	6 2
N71E-, NL71E-	7 1

## Notes

This document and any attachments may include suggested specifications, drawings, schematics and similar materials from ABB Inc. Use of such information and/or documentation by the recipient is subject to and conditioned upon your acceptance of the terms of the General Document Disclaimer which can be found at [www.jokabsafetyna.com](http://www.jokabsafetyna.com). Your acceptance of the terms of such General Document Disclaimer is conclusively presumed unless you notify ABB in writing of your disagreement with the terms of such Disclaimer immediately upon receipt of this document and you return to ABB all specifications, drawings, schematics and similar materials provided to you by ABB.



# Pilot Devices

Withstands the toughest environment!  
 Fast and easy installation saves money!  
 Aesthetic and functional design!

When you think Pilot Devices  
 ...think ABB Jokab Safety ..... 16:2

Mounting, Modular Range ..... 16:5

Modular Range  
 Pilot Devices ..... 16:6  
 Emergency Stop Pushbuttons ..... 16:8  
 Contact Blocks/Lamp Block  
 and Holder ..... 16:10  
 Accessories ..... 16:11  
 Technical Data ..... 16:17

Compact Range  
 Emergency Stop Pushbuttons ..... 16:21  
 Technical Data ..... 16:22

Assembled Stations and Empty  
 Plastic and Steel Enclosures ..... 16:24  
 Signal Towers K70 ..... 16:30



# When you think Pilot Devices... think ABB Jokab Safety!

## Part of our Comprehensive Program

ABB has a complete range of Low Voltage Control Products—including pushbuttons, selector switches and pilot lights—that are suitable for every customer's application. Our products meet all essential national and international standards.

In addition, ABB offers Low Voltage Control Products such as contactors, soft starters, direct across the line and y-delta starters, and a wide range of electronic relays, switches and sensors.

## Pilot Devices

ABB offers a complete range of 22 mm Pushbuttons, Emergency Stops and Selector Switches. These are complemented with enclosures and a wide range of accessories.

The main advantages are the robustness and the fast and easy installation ensuring cost efficiency for our customers. The ABB Pilot Devices are suitable for all types of industrial environments, indoor as well as outdoor. Other sectors of common usage include trucks, buses, trains and official buildings.

## Made for Tough Industrial Environments

- Can be used in many different applications by OEMs, panel builders, contractors, etc.
- For industrial machines and equipment, control panels and control stations
- For emergency circuits, alarm and signal equipment, traction equipment, hoists and lifts, door openers, etc.

## The Important Link

Pushbuttons and pilot lights—the world's simplest devices. They are used to make and break a circuit, pass on a message or control an operation: in short, to be a link between man and machine.

A pushbutton has to be sturdy and reliable, suitable for all environments and adaptable to widely differing requirements. Further, it should be easy to fit or set up. You will find all these features in ABB's Pilot Devices.



## Complete Range

The ABB Pilot Device family is divided into two ranges; the Modular range that includes operators, holders, contact blocks and accessories that can be combined with high flexibility. The Compact range that have all functions built-in in one single unit.

## Fast and Easy to Install

All pilot devices are easy to install. Spring-loaded tabs ensure that actuators and legend plates are in correct position. Same actuator can be used in both notched and round holes.

## Flexible—Functional—Aesthetic

- Aesthetic and functional design—tight, withstanding even the toughest environment.
- No additional protective boots are needed.
- Large text and push area, clear and visible markings for quick and easy handling.
- Different choices of bezels—black plastic or metal. Grey plastic as accessory.

Contacts are provided with wiping action. The tips of the contacts rub against each other each time the contacts close, thus forcing dust and oxide to the side. The NC block has positive opening for high performance in safety circuits.

## Worldwide Availability

ABB is represented in over 100 countries. Our full line of pilot devices meets all major international and national standards.

## Approvals



## Pilot Devices...the Modular Range

Pushbuttons, 22 mm and 30 mm  
Non-Illuminated and Illuminated

see pages 16:6 and 16:7



Emergency Stops, 22 mm  
Non-Illuminated and Illuminated

see pages 16:8 and 16:9



## Pilot Devices...the Compact Range

Emergency Stops, 22 mm  
Non-Illuminated

see page 16:21



## Accessories

see page 16:11 through 16:16  
Ask your ABB representative  
for detailed information about  
Legend Plates.



Pilot Device Adapters, 30 mm  
see page 16:14



## Assembled Stations and Empty Plastic and Steel Enclosures

see pages 16:24  
through 16:29



## Signal Towers and Signal Beacons

see pages 16:30  
through 16:33





# Pilot Devices Mounting Modular Range

**Modular range**

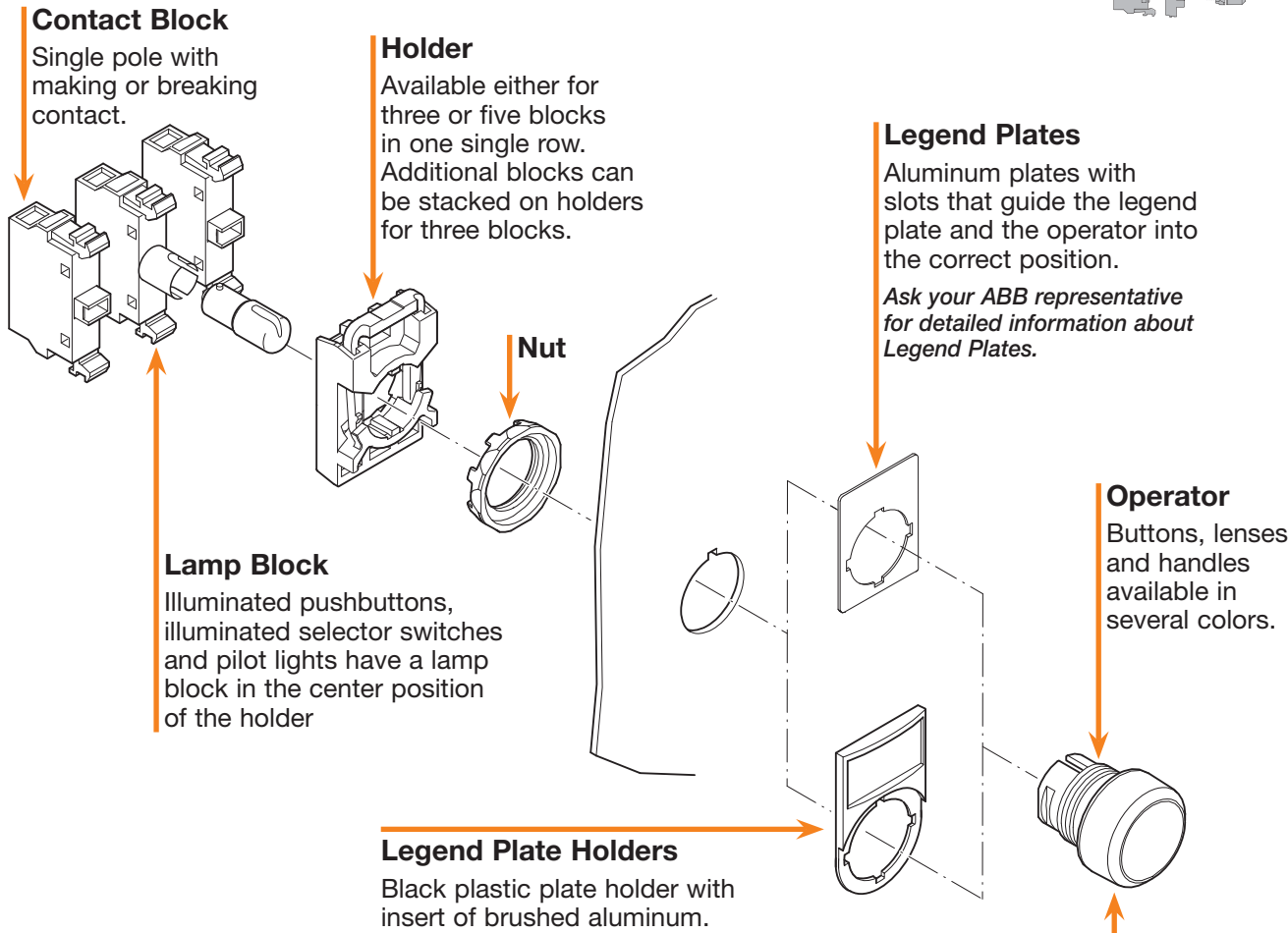
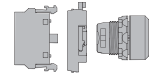

## Easy to install...

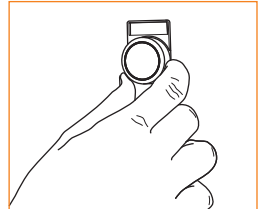

Insert the operator from the front...

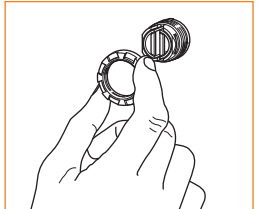

...then it secure at the back with the nut.

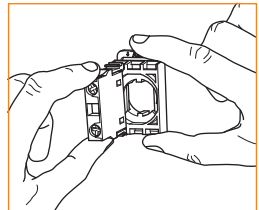

Snap contact blocks and lamp block on to the holder...

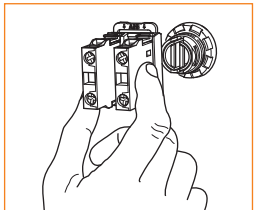

...finally, snap holder on to the operator.

## ...and remove!

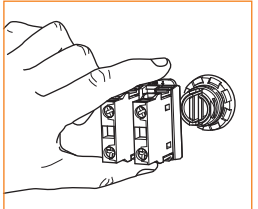

Press down the spring on holder and pull holder from actuator.

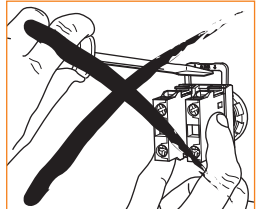

Do not use a screwdriver to remove!

## Bezel

Pushbuttons, selector switches and toggle switches with bezel available in black plastic, chrome plastic or chrome metal.

# Pilot Devices with Flush and Extended Pushbuttons (Non-Illuminated, Momentary)

**Modular range**

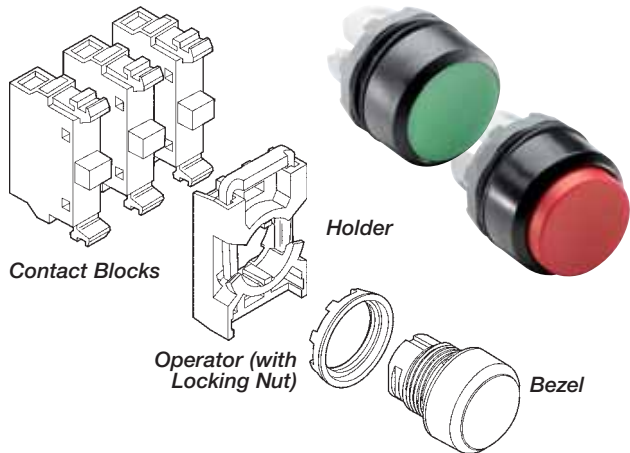
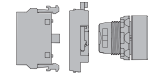

**HOW TO ORDER:**  
 Operator + Holder + Contact Block(s) OR  
 Operator + Holder with Contact Block(s)

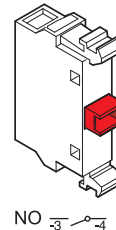
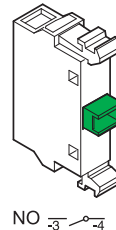

*Note: For information on contact blocks and holder see information beginning on page 16:10.*

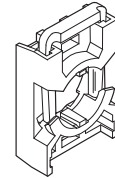

## Operator

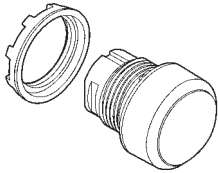
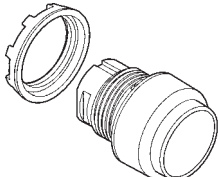
Description	Color	Part No.	Weight
Flush Button Momentary <i>Packing Quantity: 1 pc</i> 	Red	MP1-10R	0.035 lb (0.016 kg)
	Green	MP1-10G	0.035 lb (0.016 kg)
	Yellow	MP1-10Y	0.035 lb (0.016 kg)
	Blue	MP1-10L	0.035 lb (0.016 kg)
	White	MP1-10W	0.035 lb (0.016 kg)
	Black	MP1-10B	0.035 lb (0.016 kg)
	Clear	MP1-10C	0.035 lb (0.016 kg)
	Extended Button Momentary <i>Packing Quantity: 1 pc</i> 	Red	MP3-10R
Green		MP3-10G	0.035 lb (0.016 kg)
Yellow		MP3-10Y	0.035 lb (0.016 kg)
Blue		MP3-10L	0.035 lb (0.016 kg)
White		MP3-10W	0.035 lb (0.016 kg)
Black		MP3-10B	0.035 lb (0.016 kg)
Clear		MP3-10C	0.035 lb (0.016 kg)

## Bezel Options

Description	How to Order	Part No.
Black Plastic	Standard '1'	MPX-10X
Chrome Metal	Replace '2' with '3' in part number	MPX-30X



# Pilot Devices with Flush and Extended Pushbuttons (Illuminated, Momentary)

## Modular range

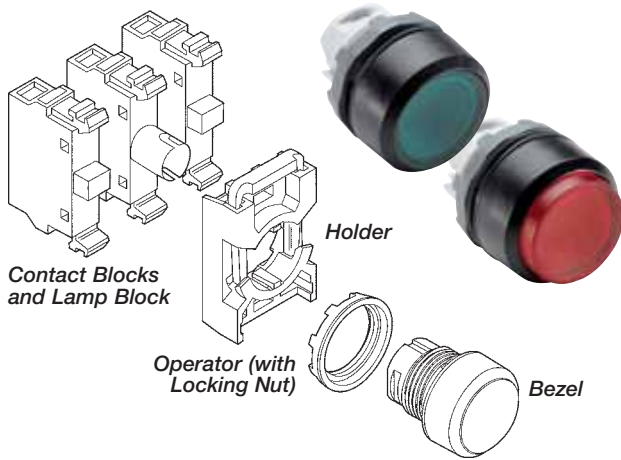
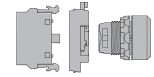

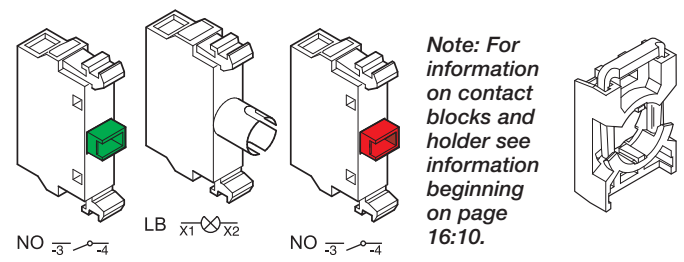

**HOW TO ORDER:**  
 Operator + Holder + Contact Block(s) + Lamp Block OR  
 Operator + Holder with Contact Block(s) and Lamp Block

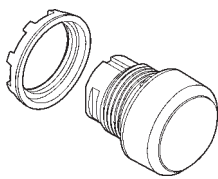
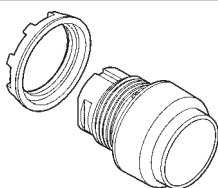

### Operator

Description	Color	Type	Weight
Flush Button Momentary <i>Packing Quantity: 1 pc</i> 	Red	MP1-11R	0.035 lb (0.016 kg)
	Green	MP1-11G	0.035 lb (0.016 kg)
	Yellow	MP1-11Y	0.035 lb (0.016 kg)
	Blue	MP1-11L	0.035 lb (0.016 kg)
	White	MP1-11W	0.035 lb (0.016 kg)
	Black	MP1-11B	0.035 lb (0.016 kg)
	Clear	MP1-11C	0.035 lb (0.016 kg)
Extended Button Momentary <i>Packing Quantity: 1 pc</i> 	Red	MP3-11R	0.035 lb (0.016 kg)
	Green	MP3-11G	0.035 lb (0.016 kg)
	Yellow	MP3-11Y	0.035 lb (0.016 kg)
	Blue	MP3-11L	0.035 lb (0.016 kg)
	White	MP3-11W	0.035 lb (0.016 kg)
	Black	MP3-11B	0.035 lb (0.016 kg)
	Clear	MP3-11C	0.035 lb (0.016 kg)

### Bezel Options

Description	How to Order	Part No.
Black Plastic 	Standard '1'	MPX-10X
Chrome Metal 	Replace '2' with '3' in part number	MPX-30X

# Emergency Stop Pushbuttons with Twist or Pull Release (Non-Illuminated and Illuminated)

**Modular range**

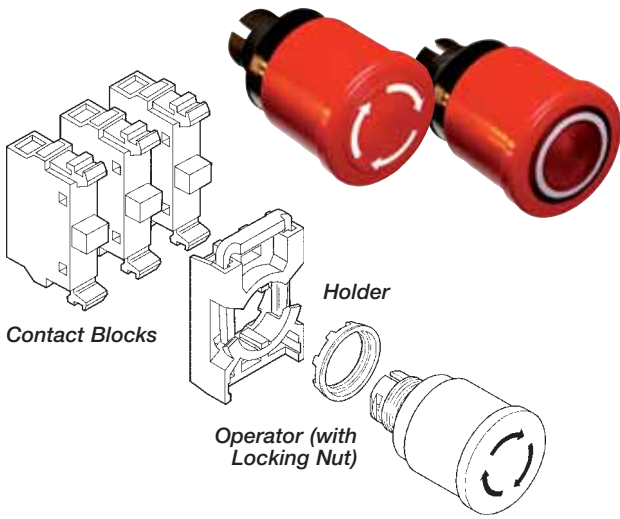
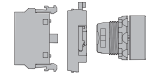

**HOW TO ORDER for Non-Illuminated:**  
 Operator + Holder + Contact Block(s) OR  
 Operator + Holder with Contact Block(s)

**HOW TO ORDER for Illuminated:**  
 Operator + Holder + Contact Block(s) + Lamp Block OR  
 Operator + Holder with Contact Block(s) and Lamp Block

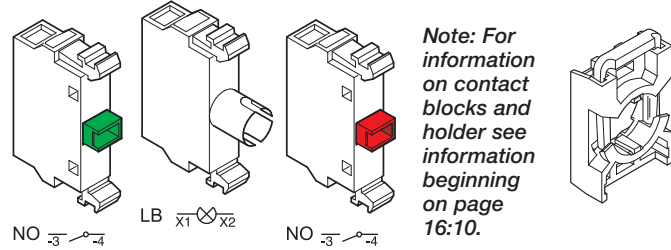

*Note: For information on contact blocks and holder see information beginning on page 16:10.*

## Operator

Description	Color	Release	Part No.	Weight
Non-Illuminated Ø 40 mm	Red	Twist	MPMT3-10R	0.091 lb (0.041 kg)
	Red	Pull	MPMP3-10R	0.091 lb (0.041 kg)
Non-Illuminated Ø 60 mm	Red	Twist	MPMT4-10R	0.106 lb (0.048 kg)
	Red	Pull	MPMP4-10R	0.106 lb (0.048 kg)
Illuminated Ø 40 mm	Red	Twist	MPMT3-11R	0.091 lb (0.041 kg)
	Red	Pull	MPMP3-11R	0.091 lb (0.041 kg)
Illuminated Ø 60 mm	Red	Twist	MPMT4-11R	0.106 lb (0.048 kg)
	Red	Pull	MPMP4-11R	0.106 lb (0.048 kg)

Packing Quantity: 1 pc

Note for Illuminated Operator: Bulb max 2 W, not included.

## ABB Emergency Stop Pushbuttons Fulfill IEC 60947-5-5

To comply with this standard, a number of tests had to be conducted with the following results:

<b>Durability Test</b>	6,050 cycles (Not a test of mechanical life. Product mechanical life: 100,000 operations.)	<b>Latching Test</b>	With 1.6 kg hammer
<b>Robustness Test</b>	Force of 113 N applied in three axes	<b>Resetting Test</b>	Pulling force < 50 N Turning torque < 1 Nm
<b>Conditioning Test</b>	Heat and cold, moist, dry and salty atmospheres, and in 5% NaCl	<b>Electrical Test</b>	According to utilization category AC15 and DC13
<b>Shock Test</b>	15 g shock	<b>Contacts with Direct Opening Action</b>	According to IEC 60947-5-1 Annex K
<b>Vibration Test</b>	2 h at 50 m/s <sup>2</sup>	<b>Note: The Emergency Stop Pushbuttons also comply with applicable parts of standards ISO 13850, EN 418 and directive 2006/42/EC, Machinery Safety.</b>	
<b>Opening Test</b>	Impulse voltage test at 2,500 V		

# Emergency Stop Pushbuttons with Twist, Pull or Key Release (Non-Illuminated)

## Modular range

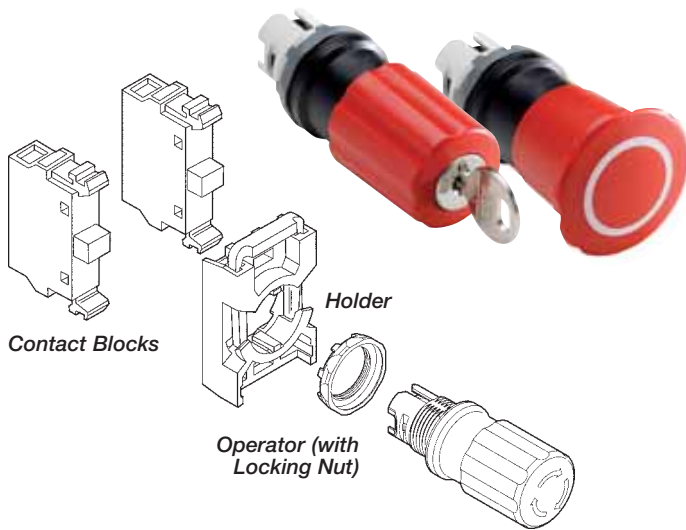
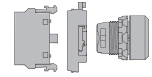

**HOW TO ORDER:**  
 Operator + Holder + Contact Block(s) OR  
 Operator + Holder with Contact Block(s)

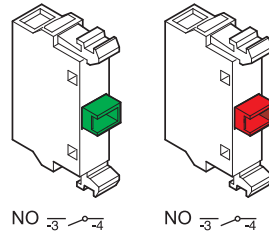

*Note: For information on contact blocks and holder see information beginning on page 16:10.*

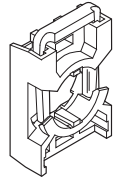

### Operator

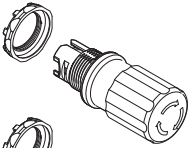
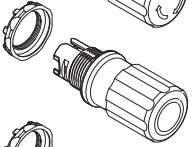
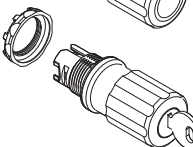
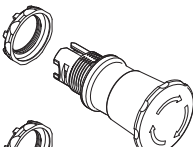
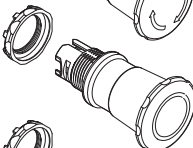
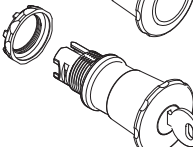
Description	Color	Key Code	Ronis Key Code	Part No.	Weight
Ø 30 mm Twist Release 	Red	n/a	n/a	MPET3-10R	0.079 lb (0.036 kg)
Ø 30 mm Pull Release 	Red	n/a	n/a	MPEP3-10R	0.079 lb (0.036 kg)
Ø 30 mm Key Release 	n/a	71	455	MPEK3-11R	0.143 lb (0.065 kg)
	n/a	72	421	MPEK3-12R	0.143 lb (0.065 kg)
	n/a	73	3433-E	MPEK3-13R	0.143 lb (0.065 kg)
Ø 40 mm Twist Release 	Red	n/a	n/a	MPET4-10R	0.079 lb (0.036 kg)
Ø 40 mm Pull Release 	Red	n/a	n/a	MPEP4-10R	0.079 lb (0.036 kg)
Ø 40 mm Key Release 	n/a	71	455	MPEK4-11R	0.143 lb (0.065 kg)
	n/a	72	421	MPEK4-12R	0.143 lb (0.065 kg)
	n/a	73	3433-E	MPEK4-13R	0.143 lb (0.065 kg)

Packing Quantity: 1 pc

Note for Illuminated Operator: Bulb max 2 W, not included.



## Contact Blocks/Lamp Block and Holder

### For Non-Illuminated Pilot Devices (Front Mounting)

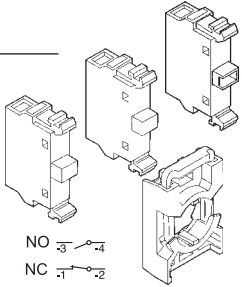
Description	Included Blocks	Part No.	Weight
Contact Blocks with Holder for 3 Blocks <i>Packing Quantity: 10 pcs</i> 	1NO	MCBH-10	0.042 lb (0.019 kg)
	1NC	MCBH-01	0.042 lb (0.019 kg)
	2NC	MCBH-20	0.071 lb (0.032 kg)
	2NC	MCBH-02	0.071 lb (0.032 kg)
	3NC	MCBH-03	0.099 lb (0.045 kg)
	3NO	MCBH-30	0.099 lb (0.045 kg)
	1NO + 1NC	MCBH-11	0.071 lb (0.032 kg)
	1NO + 2NC	MCBH-12	0.099 lb (0.045 kg)
	2NO + 1NC	MCBH-21	0.099 lb (0.045 kg)

### For Illuminated Pilot Devices (Front Mounting)

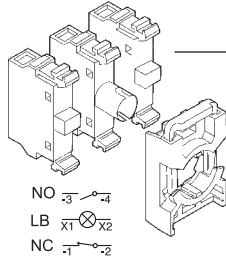
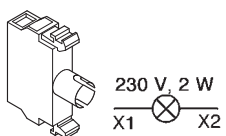
Description	Included Blocks	Part No.	Weight
Contact Blocks and Lamp Block with Holder for 3 Blocks <i>Packing Quantity: 10 pcs</i> 	1NO + 1MLB-1	MCBH-101	0.075 lb (0.034 kg)
	1NC + 1MLB-1	MCBH-011	0.075 lb (0.034 kg)
	2NO + 1MLB-1	MCBH-201	0.104 lb (0.047 kg)
	2NC + 1MLB-1	MCBH-021	0.104 lb (0.047 kg)
	1NO + 1NC + 1MLB-1	MCBH-111	0.104 lb (0.047 kg)
Lamp Block for 2 W, max 230 V AC/DC bulb or LED <i>Packing Quantity: 10 pcs</i> 	n/a	MLB-1	0.033 lb (0.015 kg)

Bulb or LED not included. Bulb max 2W

### For Non-Illuminated or Illuminated Pilot Devices (Front Mounting)

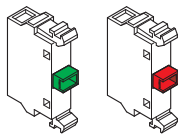
Description	Contact Block	Part No.	Weight
Contact Blocks <i>Packing Quantity: 10 pcs</i> 	1NO	MCB-10	0.029 lb (0.013 kg)
	1NC	MCB-01	0.029 lb (0.013 kg)

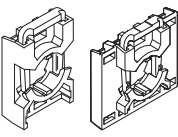

Description	Number of Blocks	Part No.	Weight
Holder <i>Packing Quantity: 10 pcs</i> 	For 3	MCBH-00	0.013 lb (0.006 kg)
	For 5	MCBH5-00	0.018 lb (0.008 kg)

Double contact block, contact block with gold plated contacts, micro contact block and other types of lamp blocks see pages 16:12 and 16:13, as well as pages 16:26 and 16:27..

## Accessories

### Contact Blocks and Lamp Block with Holder (Front Mounting)

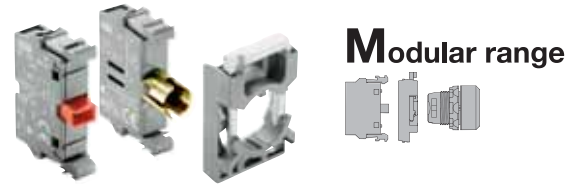

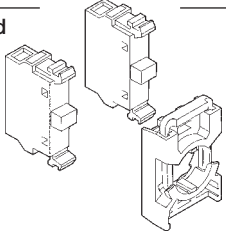
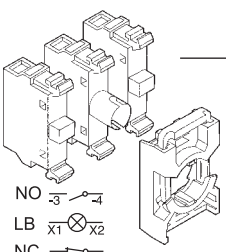
Description	Included Blocks	Part No.	Weight
For Non-Illuminated Operators <i>Packing Quantity: 10 pcs</i> 	1 NO	MCBH-10	0.042 lb (0.019 kg)
	1 NC	MCBH-01	0.042 lb (0.019 kg)
	2 NC	MCBH-20	0.071 lb (0.032 kg)
	2 NC	MCBH-02	0.071 lb (0.032 kg)
	3 NC	MCBH-03	0.099 lb (0.045 kg)
	3 NO	MCBH-30	0.099 lb (0.045 kg)
	1 NO + 1 NC	MCBH-11	0.071 lb (0.032 kg)
	1 NO + 2 NC	MCBH-12	0.099 lb (0.045 kg)
	2 NO + 1 NC	MCBH-21	0.099 lb (0.045 kg)
	For Illuminated Operators <i>Packing Quantity: 10 pcs</i>  <p>             NO <math>\overline{3}</math> <math>\rightarrow</math> <math>\overline{4}</math>              LB <math>\overline{x1}</math> <math>\otimes</math> <math>\overline{x2}</math>              NC <math>\overline{1}</math> <math>\rightarrow</math> <math>\overline{2}</math> </p>	1 NO + 1 LB (MLB-1)	MCBH-101
1 NC + 1 LB (MLB-1)		MCBH-011	0.075 lb (0.034 kg)
2 NO + 1 LB (MLB-1)		MCBH-201	0.104 lb (0.047 kg)
2 NC + 1 LB (MLB-1)		MCBH-021	0.104 lb (0.047 kg)
1 NO + 1 NC + 1 LB (MLB-1)		MCBH-111	0.104 lb (0.047 kg)

### Single Contact Blocks (Front Mounting)

Description	Included Blocks	Part No.	Weight
<i>Packing Quantity: 10 pcs</i> 	1 NO	MCB-10	0.029 lb (0.013 kg)
	1 NC	MCB-01	0.029 lb (0.013 kg)
	1 NO with gold plated contacts	MCB-10G	0.029 lb (0.013 kg)
	1 NC with gold plated contacts	MCB-01G	0.029 lb (0.013 kg)

### Micro Contact Blocks (Front Mounting)

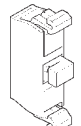
Description	Included Blocks	Part No.	Weight
<i>Packing Quantity: 10 pcs</i> 	1 NO	MCBL-10	0.022 lb (0.010 kg)
	1 NC	MCBL-01	0.022 lb (0.010 kg)

### Double Contact Block (Front Mounting)

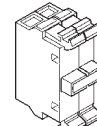
Description	Included Blocks	Part No.	Weight
<i>Packing Quantity: 10 pcs</i> 	2 NO	MCB-20	0.057 lb (0.026 kg)
	2 NC	MCB-02	0.057 lb (0.026 kg)
	1 NO + 1 NC	MCB-02	0.057 lb (0.026 kg)

To be used together with MCBH5-00 when contact blocks in position 4- and 5- are needed.  
 Also when using MCBH-00 together with selector switch and contact block in position 3- is needed.



## Accessories

### Single Lamp Blocks, BA 9s base (Front Mounting)



## Modular range

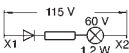
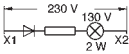
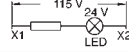
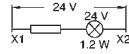

Diagram	Description	Part No.	Weight
	For max 2W, 230 V AC/DC filament bulb or LED	MLB-1	0.033 lb (0.015 kg)
	115 V AC supply voltage, for 60 V filament bulb 1.2 W	MLB-02	0.037 lb (0.017 kg)
	230 V AC supply voltage, for 130 V filament bulb 2 W	MLB-03	0.044 lb (0.020 kg)
	115 V AC/DC supply voltage, for 24 V LED only	MLB-04	0.037 lb (0.017 kg)
	24 V AC/DC supply voltage, intended for 24 V filament bulbs with extra feature to prevent current peaks	MLB-05	0.037 lb (0.017 kg)
	LED lamp block designed to prevent glowing from leakage current	MLB-08	0.033 lb (0.015 kg)

Packing  
Quantity:  
10 pcs

### Lamp Block with LED (Front Mounting)

Color	Rated Current mA	Wave-Length nm	Luminance mcd	Rated Voltage	Part No.	Weight
Red	9.9	620	250	24 V AC/DC	MLBL-01R	0.026 lb (0.012 kg)
Red	8.6	620	200	110-130 V AC	MLBL-04R	0.026 lb (0.012 kg)
Green	9.2	520	1500	24 V AC/DC	MLBL-01G	0.026 lb (0.012 kg)
Yellow	9.9	588	250	24 V AC/DC	MLBL-01Y	0.026 lb (0.012 kg)
Blue	9.3	468	450	24 V AC/DC	MLBL-01L	0.026 lb (0.012 kg)
White	9.2	X = 0.28 Y = 0.29	600	24 V AC/DC	MLBL-01W	0.026 lb (0.012 kg)

Packing  
Quantity:  
10 pcs

Designed to prevent glowing from leakage current.

### Lamp Block with LED (Rear Mounting)

Color	Rated Current mA	Wave-Length nm	Luminance mcd	Rated Voltage	Part No.	Weight
Red	9.9	620	250	24 V AC/DC	MLBL-01BR	0.026 lb (0.012 kg)
Green	9.2	520	1500	24 V AC/DC	MLBL-01BG	0.026 lb (0.012 kg)
Yellow	9.9	588	250	24 V AC/DC	MLBL-01BY	0.026 lb (0.012 kg)
Blue	9.3	468	450	24 V AC/DC	MLBL-01BL	0.026 lb (0.012 kg)
White	9.2	X = 0.28 Y = 0.29	600	24 V AC/DC	MLBL-01BW	0.026 lb (0.012 kg)

Packing  
Quantity:  
10 pcs

Designed to prevent glowing from leakage current.

Note: See pages 16:26 and 16:27 for additional contact blocks and lamp blocks for rear mounting.



## Accessories

### Holders

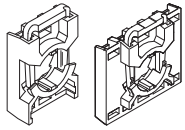

Packing  
Quantity: 10 pcs

Number of  
Blocks

Type

Weight

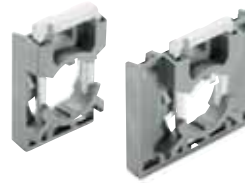

### Modular range

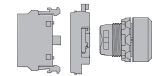

For 3

MCBH-00

0.013 lb (0.006 kg)

For 5

MCBH5-00

0.018 lb (0.008 kg)

### Transformer Block with Lamp Holder, BA 9s base (Front Mounting)

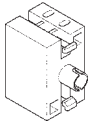

Packing  
Quantity: 1 pc

Primary  
Voltage

Secondary  
Voltage

Type

Weight

110 - 127 V AC

24 V AC\*

KTR1-1011

0.209 lb (0.095 kg)

220 - 250 V AC

24 V AC\*

KTR1-1012

0.209 lb (0.095 kg)

380 - 420 V AC

24 V AC\*

KTR1-1013

0.209 lb (0.095 kg)

440 - 480 V AC

24 V AC\*

KTR1-1014

0.209 lb (0.095 kg)

For 6 or 24 V filament bulb and \*24 V LED. Rated power 1.5 W. (Lamp Holder intended to supply a 1.2 W filament bulb.)

### Transformer Block for Illuminated Operators (Front Mounting)

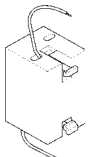

Packing  
Quantity: 1 pc

Primary  
Voltage

Secondary  
Voltage

Type

Weight

110 - 127 V AC

24 V AC\*

KTR1-2011

0.209 lb (0.095 kg)

220 - 250 V AC

24 V AC\*

KTR1-2012

0.209 lb (0.095 kg)

380 - 420 V AC

24 V AC\*

KTR1-2013

0.209 lb (0.095 kg)

440 - 480 V AC

24 V AC\*

KTR1-2014

0.209 lb (0.095 kg)

To be used with lamp block MLB-1 (1SFA611 620R1001) and 1.2 W filament bulb. \*Can be used with LED bulb.

### Diode Block

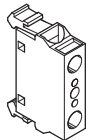

Packing  
Quantity: 10 pcs

Diagram for  
lamp test  
with three  
diode block

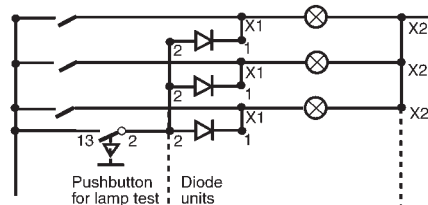

Type

Weight

MDB-1001

0.022 lb (0.010 kg)

To be used if several lamps are to be connected to a common lamp-test pushbutton.

A diode must be connected in series with each lamp. The diode block snaps onto the lamp block or is placed at the side.

### Dummy Block

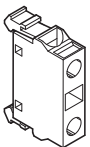

Packing  
Quantity: 10 pcs

Type

Weight

MDB-2

0.022 lb (0.010 kg)

## Accessories



## Modular range

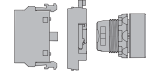

### DIN-Rail Adapter/Kit

#### Description

DIN-rail adapter

*Packing Quantity: 1 pc*

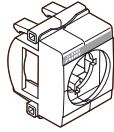

#### Part No.

MA1-8131

#### Weight

0.044 lb (0.020 kg)

DIN-rail adapter kit  
for use when only  
one contact block  
or lamp is required

*Packing Quantity: 1 pc*

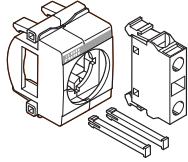

MA1-8001

0.062 lb (0.028 kg)

### 30 mm Adapters

#### Description

For emergency  
stop pushbuttons

*Packing Quantity: 1 pc*

*MPM style E-Stop ONLY!  
All other emergency stop  
styles use KA1-8029 and  
KA1-8030*

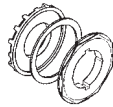

#### Material

Black Plastic

#### Part No.

KA1-8027

#### Weight

0.015 lb (0.007 kg)

Metal

KA1-8028

0.046 lb (0.021 kg)

For pushbuttons, selector  
switches, pilot lights,  
potentiometers and buzzers

*Packing Quantity: 1 pc*



Black Plastic

KA1-8029

0.022 lb (0.010 kg)

Metal

KA1-8030

0.077 lb (0.035 kg)

### Adapters for Flush Mounted Pilot Devices

#### Description

For pushbuttons

*Packing Quantity: 1 pc*



#### Part No.

KA1-8073

#### Weight

0.110 lb (0.050 kg)

For selector switches

*Packing Quantity: 1 pc*



KA1-8073

0.110 lb (0.050 kg)

### Lamp Changing Tool

#### Description

For pushbuttons

*Packing Quantity: 1 pc*

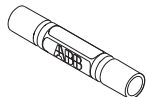

#### Part No.

KA1-8072

#### Weight

0.004 lb (0.002 kg)

### Mounting Tool

#### Description

For tightening the locking nut

*Packing Quantity: 1 pc*

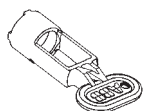

#### Color

Grey

#### Part No.

65

#### Weight

0.046 lb (0.021 kg)

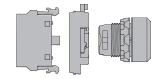

## Accessories

### Extra Key

Description	Key Code	Part No.	Weight
Ronis 455	71	SK 616 021-71	0.015 lb (0.007 kg)
Ronis 421	72	SK 616 021-72	0.015 lb (0.007 kg)
Ronis 3433-E	73	SK 616 021-73	0.015 lb (0.007 kg)

*Packing Quantity: 1 pc*



### Locking Nut

Description	Part No.	Weight
<i>Packing Quantity: 10 pcs</i>	MA1-8019	0.002 lb (0.001 kg)



### 22 mm Blanking Plug

Description	Color	Part No.	Weight
<i>Packing Quantity: 10 pcs</i>	Grey	MA1-8129	0.011 lb (0.005 kg)
	Black	MA1-8130	0.011 lb (0.005 kg)

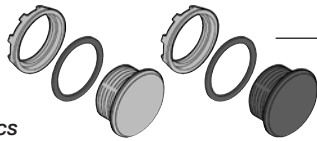

### Square Bezel

Description	Color	Part No.	Weight
<i>Packing Quantity: 10 pcs</i>	Grey	MA1-8124	0.002 lb (0.004 kg)
	Black	SK 616 016-2	0.002 lb (0.004 kg)



### Silicon Rubber Membrane

Description	Application	Part No.	Weight
Transparent, heat/cold resistant silicon rubber. Does not harden at low temperature. Gives IP 67 degree of protection. <i>Packing Quantity: 10 pcs</i>	For flush button	KA1-8052	0.002 lb (0.004 kg)
	For extended button	KA1-8002	0.002 lb (0.004 kg)
	For double pushbutton	MA1-8126	0.002 lb (0.004 kg)



*Note: When membrane is used, remove the gasket.*

### Protective Ring

Description	Application	Part No.	Weight
To prevent accidental operation. <i>Packing Quantity: 10 pcs</i>	For flush and extended buttons	SK 615 512-1	0.002 lb (0.004 kg)



*Not together with legend plate holder.*

### Legend Plates and Holder

Description	
Legend Plate	Aluminum plates with slots that guide the legend plate and the operator into the correct position
Legend Plate Holder	Black plastic plate holder with insert of brushed aluminum

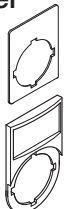

*Ask your ABB representative for detailed information about Legend Plates and Holders.*

## Accessories



## Modular range

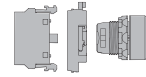

### Bezel

Description		Material	Part No.	Weight
For pushbutton		Grey plastic	KA1-8079	0.002 lb (0.001 kg)
		Black plastic	KA1-8022	0.002 lb (0.001 kg)
		Chrome metal	KA1-8021	0.033 lb (0.015 kg)
For selector switch		Grey plastic	KA1-8077	0.002 lb (0.001 kg)
		Black plastic	KA1-8080	0.002 lb (0.001 kg)
		Chrome metal	KA1-8024	0.022 lb (0.010 kg)
For reset pushbutton		Black plastic	KA1-8122	0.002 lb (0.001 kg)
<i>Packing Quantity: 10 pcs</i>		Chrome metal	KA1-8123	0.022 lb (0.010 kg)

### Emergency Stop Shroud

Description		Color	Part No.	Weight
For 40 mm emergency stop and machine stop pushbuttons to prevent accidental operation. With anti-rotation tabs and a slot for pad-lock and water drainage. <i>Packing Quantity: 10 pcs</i>		Yellow	MA1-8053	0.044 lb (0.020 kg)
		Grey	MA1-8128	0.044 lb (0.020 kg)

### Protective Cover

Description		Part No.	Weight
For flush button to prevent accidental operation. <i>Packing Quantity: 10 pcs</i>		KA1-8010	0.018 lb (0.008 kg)



*Not together with legend plate holder.*

### LEDs

Description	Color	Rated Current mA	Wave-Length nm	Luminance mcd	Part No.	Weight
Rated voltage 24 V (AC)/DC Service life > 50,000 h <i>Packing Quantity: 10 pcs</i>	Red	15	630	250	KA2-2021	0.011 lb (0.005 kg)
	Green	15	525	800	KA2-2022	0.011 lb (0.005 kg)
Rated voltage 110-130 V AC Service life 25,000 h <i>Packing Quantity: 10 pcs</i>	Yellow	15	592	250	KA2-2023	0.011 lb (0.005 kg)
	Blue	15	470	400	KA2-2024	0.011 lb (0.005 kg)
	White	15	X = 0.31 Y = 0.32	500	KA2-2025	0.011 lb (0.005 kg)
Rated voltage 110-130 V AC Service life 25,000 h <i>Packing Quantity: 10 pcs</i>	Red	4-6	630	60 - 100	KA2-2131	0.011 lb (0.005 kg)
	Green	4-6	525	500 - 850	KA2-2132	0.011 lb (0.005 kg)
	Yellow	4-6	592	70 - 120	KA2-2133	0.011 lb (0.005 kg)
	Blue	4-6	470	220 - 350	KA2-2134	0.011 lb (0.005 kg)
	White	4-6	X = 0.31 Y = 0.32	350 - 600	KA2-2135	0.011 lb (0.005 kg)

*With one diode chip mounted on a BA 9s base. Choose the same color for the LED and the lamp cap or else use a clear lamp cap.  
Note: At DC the lamp base has to be connected to cathode (- / x2) and the bottom contact to anode (+ / x1).*

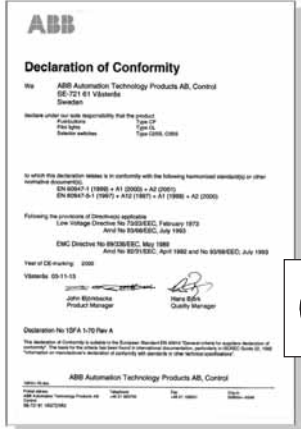
## Technical Data Pilot Devices, Modular Range 22 mm

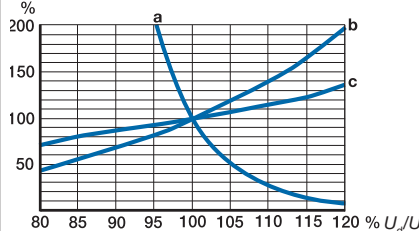

<p><b>Standards</b></p> <p><b>IEC 60947-1</b> Low-voltage switchgear and control-gear - Part 1: General rules</p> <p><b>IEC 60947-5-1</b> Low-voltage switchgear and control-gear - Part 5-1: Control circuit devices and switching elements - Electromechanical control circuit devices</p> <p><b>IEC 60947-5-5</b> Low-voltage switchgear and control-gear - Part 5-5: Control circuit devices and switching elements - Electrical emergency stop device with mechanical latching function</p> <p><b>IEC 60073</b> Basic and safety principles for man-machine interface, marking and identification - Coding principles for indicators and actuators</p> <p><b>IEC 60529</b> Degrees of protection provided by enclosures (IP Code)</p> <p><b>EN 60947-1</b> Low-voltage switchgear and control-gear - Part 1: General rules</p> <p><b>EN 60947-5-1</b> Low-voltage switchgear and control-gear - Part 5-1: Control circuit devices and switching elements - Electromechanical control circuit devices</p> <p><b>EN 60947-5-5</b> Low-voltage switchgear and control-gear - Part 5-5: Control circuit devices and switching elements - Electrical emergency stop device with mechanical latching function</p> <p><b>EN 60073</b> Basic and safety principles for man-machine interface, marking and identification - Coding principles for indication devices and actuators</p> <p><b>EN 60529</b> Degrees of protection provided by enclosures (IP Code)</p> <p><b>EN 50013</b> Low-voltage switchgear and control-gear for industrial use - Terminal marking and distinctive number for particular control switches</p> <p><b>UL 508</b> <b>CSA C22.2 No 14</b> Industrial Control Equipment</p>	<p>All front parts are made of polycarbonate. PC Polycarbonate</p> <p>High impact strength, good outdoor resistance. Can withstand light acid solutions, aliphatic hydrocarbons, paraffin, alcohols, animal and vegetable greases.</p> <p>Can withstand high temperatures, acids, basic solutions, alkaline compounds, oils, alcohols.</p> <p>Can withstand high temperatures, aliphatic, aromatic and chlorinated hydrocarbons, esters, ketone-aldehydes, alcohols and basic solutions.</p> <p>Can withstand high temperature, aliphatic and aromatic hydrocarbons, acids, basic solutions, alcohols, grease and oils.</p> <p>Good corrosion resistance in inland, sea and industrial atmosphere.</p> <p>Good corrosion resistance in inland, sea and industrial atmosphere.</p> <p>Chloroprene Nitrile</p> <p><i>No ozone depleting substances in the products.</i></p>	<p><b>Degrees of Protection</b></p> <p><b>Operators</b></p> <p>Pushbutton with flush or extended button, <b>MP</b></p> <p>Double pushbutton, <b>MPD</b></p> <p>Mushroom pushbutton, momentary, <b>MPM</b></p> <p>Emergency stop pushbutton, <b>MPMT/P</b></p> <p>Selector switch, <b>M2SS/M3SS</b></p> <p>Key operated selector switch, <b>M2SSK/M3SSK</b></p> <p>Toggle switch, <b>MTS2/MTS3</b></p> <p>Definite purpose pushbutton, 30 mm, <b>KP6</b></p> <p>Reset button, <b>KPR</b></p> <p>Pilot lights, <b>ML</b></p> <p>Buzzer, <b>KB</b></p> <p>Potentiometer, <b>MT</b></p> <p>Accessories, <b>MA1</b></p> <p><b>Contact block and transformer block</b></p> <p>Plastic enclosures</p> <p>Metallic enclosures</p>	<p>UV protection according to UL 746 (C)</p> <p>IP 66 UL/CSA Type 1, 3R, 4, 4X, 12, 13</p> <p>IP 66 UL/CSA Type1, 3R, 4, 4X, 12, 13</p> <p>IP 66 UL/CSA Type 1, 3R, 4, 4X, 12, 13</p> <p>IP 66 UL/CSA Type 1, 3R, 4, 4X, 12, 13</p> <p>IP 66 UL/CSA Type 1, 3R, 4, 4X, 12, 13</p> <p>IP 66 UL/CSA Type 1, 3R, 4, 4X, 12, 13</p> <p>IP 66 UL/CSA Type 1, 3R, 4, 4X, 12, 13</p> <p>IP 66 UL/CSA Type 1, 3R, 4, 4X, 12, 13</p> <p>IP 66 UL/CSA Type 1, 3R, 4, 4X, 12, 13</p> <p>IP 66 UL/CSA Type 1, 3R, 4, 4X, 12, 13</p> <p>IP 20 UL/CSA Type 1, 3R, 4, 4X, 12, 13</p> <p>IP 66 UL/CSA Type 1, 3R, 4, 4X, 12, 13</p> <p>IP 67 UL/CSA Type 1, 3R, 4, 4X, 12, 13</p>
<p><b>Material</b></p> <p>PC Polycarbonate</p> <p>PSU Polysulphone</p> <p>PA Polyamide</p> <p>PBT</p> <p>Zinc</p> <p>Light-alloy</p> <p>Rubber</p>	<p>All front parts are made of polycarbonate. PC Polycarbonate</p> <p>High impact strength, good outdoor resistance. Can withstand light acid solutions, aliphatic hydrocarbons, paraffin, alcohols, animal and vegetable greases.</p> <p>Can withstand high temperatures, acids, basic solutions, alkaline compounds, oils, alcohols.</p> <p>Can withstand high temperatures, aliphatic, aromatic and chlorinated hydrocarbons, esters, ketone-aldehydes, alcohols and basic solutions.</p> <p>Can withstand high temperature, aliphatic and aromatic hydrocarbons, acids, basic solutions, alcohols, grease and oils.</p> <p>Good corrosion resistance in inland, sea and industrial atmosphere.</p> <p>Good corrosion resistance in inland, sea and industrial atmosphere.</p> <p>Chloroprene Nitrile</p> <p><i>No ozone depleting substances in the products.</i></p>	<p><b>Approvals</b></p> <p>The pushbuttons, selector switches and pilot lights are approved by National approval agencies UL, CSA and China Compulsory Product Certification</p> <p><i>For detail information please contact ABB.</i></p>	  

## Technical Data Pilot Devices, Modular Range 22 mm continued

<b>Mechanical Life Operators</b> Pushbuttons with flush or extended button, momentary mushroom push-button Selector switch, maintained mushroom pushbutton, key operated selector switch and double pushbutton Emergency stop pushbutton Toggle switch Lockable pushbuttons	2 million operations  0.5 million operations  0.1 million operations 1 million operations 0.3 million operations												
<b>Temperature</b> Ambient temperature during operation <i>Exception: All pilot devices with 2 W continuously lit filament bulb.</i> Storage temperature	-25 to +70 °C  -25 to +40 °C  -30 to +85 °C												
<b>Terminals</b>  Connectable area  Recommended torque	Plus-minus Pozidriv No. 2 screw with DIN-washer min. 1 x 0.5 mm <sup>2</sup> /AWG 20 max. 2 x 2.5 mm <sup>2</sup> /2 x AWG14 0.9 Nm												
<b>Tightening Torque</b> Locking nut, M22	min. 2 Nm / max. 2.3 Nm												
<b>Lamp Block</b> <b>Ratings as per IEC 60 947-5-1</b> Rated insulation voltage Base Permissible power, up to <b>Service life of filament bulb</b> <i>Relative service life, luminous flux and power consumption at different service voltages. It is generally true to say that bulbs for lower voltages give more light and have better vibration-withstand capability than bulbs for higher voltages.</i> <b>Lamp Comparison</b> Approx life (hours) Shock and service immunity High vibration temperature Low power operating Brightness consumption	230 V Ba 9s 2 W  a = service life (H) / b = luminous flux (lm) c = power (W) / U <sub>d</sub> = service voltage, V U <sub>m</sub> = bulb voltage (V) <table border="1"> <tr> <td>Filament bulb</td> <td>LED bulb</td> </tr> <tr> <td>5,000-10,000</td> <td>25,000-50,000</td> </tr> <tr> <td>+</td> <td>+++</td> </tr> <tr> <td>+</td> <td>++</td> </tr> <tr> <td>+</td> <td>++</td> </tr> <tr> <td>+++</td> <td>++</td> </tr> </table> Very good +++ / Good ++ / Less Good +	Filament bulb	LED bulb	5,000-10,000	25,000-50,000	+	+++	+	++	+	++	+++	++
Filament bulb	LED bulb												
5,000-10,000	25,000-50,000												
+	+++												
+	++												
+	++												
+++	++												

<b>Contact Blocks</b> Mechanical endurance	10 million operations <i>Self cleaning contacts of silver, NC contact with positive opening.</i> <i>At voltages and currents below 24 V and 5.6 mA two contact blocks in parallel are recommended. As an alternative, gold plated contacts can be used.</i>																
Ratings as per UL, CSA, NEMA	<table border="1"> <tr> <td></td> <td><b>A600</b></td> <td><b>Q600</b></td> </tr> <tr> <td></td> <td>AC</td> <td>DC</td> </tr> </table>		<b>A600</b>	<b>Q600</b>		AC	DC										
	<b>A600</b>	<b>Q600</b>															
	AC	DC															
Rated insulation voltage	600 V                      600 V																
Rated thermal current	10 A                                      2.5 A																
Rated operational current	<table border="1"> <tr> <td>at 120 V</td> <td>6 A</td> <td>at 125 V</td> <td>0.55 A</td> </tr> <tr> <td>at 240 V</td> <td>3 A</td> <td>at 250 V</td> <td>0.27 A</td> </tr> <tr> <td>at 480 V</td> <td>1.5 A</td> <td>at 480 V</td> <td>0.10 A</td> </tr> <tr> <td>at 600 V</td> <td>1.2 A</td> <td>at 600 V</td> <td>0.10 A</td> </tr> </table>	at 120 V	6 A	at 125 V	0.55 A	at 240 V	3 A	at 250 V	0.27 A	at 480 V	1.5 A	at 480 V	0.10 A	at 600 V	1.2 A	at 600 V	0.10 A
at 120 V	6 A	at 125 V	0.55 A														
at 240 V	3 A	at 250 V	0.27 A														
at 480 V	1.5 A	at 480 V	0.10 A														
at 600 V	1.2 A	at 600 V	0.10 A														
<b>Ratings as per IEC 60 947-5-1</b> Rated insulation voltage, U <sub>i</sub> Rated thermal current, I <sub>th</sub> Rated operational current, I <sub>e</sub> utilization category AC 15	690 V  10 A at 120 V 8 A at 230 V 6 A at 400 V 4 A at 690 V 2 A at 24 V 5 A at 125 V 1.1 A at 250 V 0.55 A < 25 mΩ																
Rated operational current, I <sub>e</sub> utilization category DC 13	< 25 mΩ																
<b>Contact resistance</b> <b>Compulsory function test</b> <b>Max. number of contact blocks per operator</b>	at 5V 16 mA <i>The contact blocks can be stacked in max. two levels on the 3-block holder. Only one level is accepted on the 5-block holder.</i>																
Pushbutton, toggle switch and mushroom pushbutton Maintained pushbutton Double pushbutton, selector switch, key operated selector switch and emergency stop pushbutton <b>Short circuit protection</b> Max. fuse at 1 kA <b>Gold contacts</b> Ratings per UL508 <b>Micro block</b> Ratings per UL508 Minimum switching capacity	6 4 4 16 A ordinary / 10 A delayed 5 V, 12 mA / 12 V, 1 mA 125 VAC, 3 A / 60 VDC, 2 A / 48 VDC, 1 A 3 VDC, 1 mA																
<b>Transformer Block</b>  Rated power Rated voltage Rated insulation voltage according to IEC 70 °C (DT)	<i>Suitable for filament bulb 6 or 24 V AC and 1.2 W and LED 24 V</i> 1.5 W Ratio, see Accessories page 16:15 Class E																

# Technical Data Pilot Devices, Modular Range 30 mm

<p><b>Standards</b></p> <p><b>IEC 60947-1</b> Low-voltage switchgear and control-gear - Part 1: General rules</p> <p><b>IEC 60947-5-1</b> Low-voltage switchgear and control-gear - Part 5-1: Control circuit devices and switching elements - Electromechanical control circuit devices</p> <p><b>IEC 60947-5-5</b> Low-voltage switchgear and control-gear - Part 5-5: Control circuit devices and switching elements - Electrical emergency stop device with mechanical latching function</p> <p><b>IEC 60073</b> Basic and safety principles for man-machine interface, marking and identification - Coding principles for indicators and actuators</p> <p><b>IEC 60529</b> Degrees of protection provided by enclosures (IP Code)</p> <p><b>EN 60947-1</b> Low-voltage switchgear and control-gear - Part 1: General rules</p> <p><b>EN 60947-5-1</b> Low-voltage switchgear and control-gear - Part 5-1: Control circuit devices and switching elements - Electromechanical control circuit devices</p> <p><b>EN 60947-5-5</b> Low-voltage switchgear and control-gear - Part 5-5: Control circuit devices and switching elements - Electrical emergency stop device with mechanical latching function</p> <p><b>EN 60073</b> Basic and safety principles for man-machine interface, marking and identification - Coding principles for indication devices and actuators</p> <p><b>EN 60529</b> Degrees of protection provided by enclosures (IP Code)</p> <p><b>EN 50013</b> Low-voltage switchgear and control-gear for industrial use - Terminal marking and distinctive number for particular control switches</p> <p><b>UL 508</b> <b>CSA C22.2 No 14</b> Industrial Control Equipment Industrial Control Equipment</p>	<p>All front parts are made of polycarbonate. PC Polycarbonate</p> <p>High impact strength, good outdoor resistance. Can withstand light acid solutions, aliphatic hydrocarbons, paraffin, alcohols, animal and vegetable greases.</p> <p>PSU Polysulphone</p> <p>Can withstand high temperatures, acids, basic solutions, alkaline compounds, oils, alcohols.</p> <p>PA Polyamide</p> <p>Can withstand high temperatures, aliphatic, aromatic and chlorinated hydrocarbons, esters, ketone-aldehydes, alcohols and basic solutions.</p> <p>PBT</p> <p>Can withstand high temperature, aliphatic and aromatic hydrocarbons, acids, basic solutions, alcohols, grease and oils.</p> <p>Zinc</p> <p>Good corrosion resistance in inland, sea and industrial atmosphere.</p> <p>Light-alloy</p> <p>Good corrosion resistance in inland, sea and industrial atmosphere.</p> <p>Rubber</p> <p>Chloroprene Nitrile</p> <p><i>No ozone depleting substances in the products.</i></p>	<p><b>Degrees of Protection</b></p> <p><b>Operators</b></p> <p>Pushbutton with flush or extended button, <b>MP</b></p> <p>Double pushbutton, <b>MPD</b></p> <p>Mushroom pushbutton, momentary, <b>MPM</b></p> <p>Emergency stop pushbutton, <b>MPMT/P</b></p> <p>Selector switch, <b>M2SS/M3SS</b></p> <p>Key operated selector switch, <b>M2SSK/M3SSK</b></p> <p>Toggle switch, <b>MTS2/MTS3</b></p> <p>Definite purpose pushbutton, 30 mm, <b>KP6</b></p> <p>Reset button, <b>KPR</b></p> <p>Pilot lights, <b>ML</b></p> <p>Buzzer, <b>KB</b></p> <p>Potentiometer, <b>MT</b></p> <p>Accessories, <b>MA1</b></p> <p><b>Contact block and transformer block</b></p> <p>Plastic enclosures</p> <p>Metallic enclosures</p>	<p>IP 66 UL/CSA Type 1, 3R, 4, 4X, 12, 13</p> <p>IP 66 UL/CSA Type1, 3R, 4, 4X, 12, 13</p> <p>IP 66 UL/CSA Type 1, 3R, 4, 4X, 12, 13</p> <p>IP 66 UL/CSA Type 1, 3R, 4, 4X, 12, 13</p> <p>IP 66 UL/CSA Type 1, 3R, 4, 4X, 12, 13</p> <p>IP 66 UL/CSA Type 1, 3R, 4, 4X, 12, 13</p> <p>IP 66 UL/CSA Type 1, 3R, 4, 4X, 12, 13</p> <p>IP 66 UL/CSA Type 1, 3R, 4, 4X, 12, 13</p> <p>IP 66 UL/CSA Type 1, 3R, 4, 4X, 12, 13</p> <p>IP 66 UL/CSA Type 1, 3R, 4, 4X, 12, 13</p> <p>IP 66 UL/CSA Type 1, 3R, 4, 4X, 12, 13</p> <p>IP 20 UL/CSA Type 1, 3R, 4, 4X, 12, 13</p> <p>IP 66 UL/CSA Type 1, 3R, 4, 4X, 12, 13</p> <p>IP 67</p>
<p><b>Material</b></p> <p>PC Polycarbonate</p> <p>PSU Polysulphone</p> <p>PA Polyamide</p> <p>PBT</p> <p>Zinc</p> <p>Light-alloy</p> <p>Rubber</p>	<p>All front parts are made of polycarbonate. PC Polycarbonate</p> <p>High impact strength, good outdoor resistance. Can withstand light acid solutions, aliphatic hydrocarbons, paraffin, alcohols, animal and vegetable greases.</p> <p>PSU Polysulphone</p> <p>Can withstand high temperatures, acids, basic solutions, alkaline compounds, oils, alcohols.</p> <p>PA Polyamide</p> <p>Can withstand high temperatures, aliphatic, aromatic and chlorinated hydrocarbons, esters, ketone-aldehydes, alcohols and basic solutions.</p> <p>PBT</p> <p>Can withstand high temperature, aliphatic and aromatic hydrocarbons, acids, basic solutions, alcohols, grease and oils.</p> <p>Zinc</p> <p>Good corrosion resistance in inland, sea and industrial atmosphere.</p> <p>Light-alloy</p> <p>Good corrosion resistance in inland, sea and industrial atmosphere.</p> <p>Rubber</p> <p>Chloroprene Nitrile</p> <p><i>No ozone depleting substances in the products.</i></p>	<p><b>Approvals</b></p> <p>The pushbuttons, selector switches and pilot lights are approved by National approval agencies UL, CSA and China Compulsory Product Certification</p> <p><i>For detail information please contact ABB.</i></p>	<p></p> <p></p> <p></p>

## Technical Data Pilot Devices, Modular Range 30 mm continued

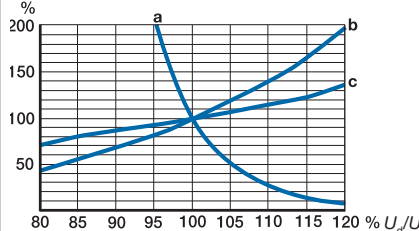
<b>Mechanical Life Operators</b> Pushbuttons with flush or extended button, momentary mushroom push-button Selector switch, maintained mushroom pushbutton, key operated selector switch and double pushbutton Emergency stop pushbutton Toggle switch Lockable pushbuttons	2 million operations  0.5 million operations  0.1 million operations 1 million operations 0.3 million operations												
<b>Temperature</b> Ambient temperature during operation <i>Exception:</i> All pilot devices with 2 W continuously lit filament bulb. Storage temperature	-25 to +70 °C  -25 to +40 °C  -30 to +85 °C												
<b>Terminals</b>  Connectable area  Recommended torque	Plus-minus Pozidriv No. 2 screw with DIN-washer  min. 1 x 0.5 mm <sup>2</sup> /AWG 20 max. 2 x 2.5 mm <sup>2</sup> /2 x AWG14  0.9 Nm												
<b>Tightening Torque</b> Locking nut, M22	min. 2 Nm / max. 2.3 Nm												
<b>Lamp Block</b> <b>Ratings as per IEC 60 947-5-1</b> Rated insulation voltage Base Permissible power, up to <b>Service life of filament bulb</b> <i>Relative service life, luminous flux and power consumption at different service voltages. It is generally true to say that bulbs for lower voltages give more light and have better vibration-withstand capability than bulbs for higher voltages.</i> <b>Lamp Comparison</b> Approx life (hours) Shock and service immunity High vibration temperature Low power operating Brightness consumption	230 V Ba 9s  2 W  a = service life (H) / b = luminous flux (lm) c = power (W) / U <sub>d</sub> = service voltage, V U <sub>m</sub> = bulb voltage (V)  <table border="1"> <tr> <td>Filament bulb</td> <td>LED bulb</td> </tr> <tr> <td>5,000-10,000</td> <td>25,000-50,000</td> </tr> <tr> <td>+</td> <td>+++</td> </tr> <tr> <td>+</td> <td>++</td> </tr> <tr> <td>+</td> <td>++</td> </tr> <tr> <td>+++</td> <td>++</td> </tr> </table> Very good +++ / Good ++ / Less Good +	Filament bulb	LED bulb	5,000-10,000	25,000-50,000	+	+++	+	++	+	++	+++	++
Filament bulb	LED bulb												
5,000-10,000	25,000-50,000												
+	+++												
+	++												
+	++												
+++	++												

<b>Contact Blocks</b> Mechanical endurance  Ratings as per UL, CSA, NEMA  Rated insulation voltage Rated thermal current Rated operational current	10 million operations <i>Self cleaning contacts of silver, NC contact with positive opening.</i> <i>At voltages and currents below 24 V and 5.6 mA two contact blocks in parallel are recommended. As an alternative, gold plated contacts can be used.</i>  <table border="1"> <tr> <td></td> <td><b>A600</b></td> <td><b>Q600</b></td> </tr> <tr> <td></td> <td>AC</td> <td>DC</td> </tr> <tr> <td></td> <td>600 V</td> <td>600 V</td> </tr> <tr> <td></td> <td>10 A</td> <td>2.5 A</td> </tr> <tr> <td>at 120 V</td> <td>6 A</td> <td>at 125 V 0.55 A</td> </tr> <tr> <td>at 240 V</td> <td>3 A</td> <td>at 250 V 0.27 A</td> </tr> <tr> <td>at 480 V</td> <td>1.5 A</td> <td>at 480 V 0.10 A</td> </tr> <tr> <td>at 600 V</td> <td>1.2 A</td> <td>at 600 V 0.10 A</td> </tr> </table>		<b>A600</b>	<b>Q600</b>		AC	DC		600 V	600 V		10 A	2.5 A	at 120 V	6 A	at 125 V 0.55 A	at 240 V	3 A	at 250 V 0.27 A	at 480 V	1.5 A	at 480 V 0.10 A	at 600 V	1.2 A	at 600 V 0.10 A
	<b>A600</b>	<b>Q600</b>																							
	AC	DC																							
	600 V	600 V																							
	10 A	2.5 A																							
at 120 V	6 A	at 125 V 0.55 A																							
at 240 V	3 A	at 250 V 0.27 A																							
at 480 V	1.5 A	at 480 V 0.10 A																							
at 600 V	1.2 A	at 600 V 0.10 A																							
<b>Ratings as per IEC 60 947-5-1</b> Rated insulation voltage, U <sub>i</sub> Rated thermal current, I <sub>th</sub> Rated operational current, I <sub>e</sub> utilization category AC 15  Rated operational current, I <sub>e</sub> utilization category DC 13 <b>Contact resistance</b> <b>Compulsory function test</b> <b>Max. number of contact blocks per operator</b> Pushbutton, toggle switch and mushroom pushbutton Maintained pushbutton Double pushbutton, selector switch, key operated selector switch and emergency stop pushbutton <b>Short circuit protection</b> Max. fuse at 1 kA <b>Gold contacts</b> Ratings per UL508 <b>Micro block</b> Ratings per UL508 Minimum switching capacity	690 V  10 A at 120 V 8 A at 230 V 6 A at 400 V 4 A at 690 V 2 A  at 24 V 5 A at 125 V 1.1 A at 250 V 0.55 A  < 25 mΩ  at 5V 16 mA <i>The contact blocks can be stacked in max. two levels on the 3-block holder. Only one level is accepted on the 5-block holder.</i>  6 4 4  16 A ordinary / 10 A delayed 5 V, 12 mA / 12 V, 1 mA 125 VAC, 3 A / 60 VDC, 2 A / 48 VDC, 1 A 3 VDC, 1 mA																								
<b>Transformer Block</b>  Rated power Rated voltage Rated insulation voltage according to IEC 70 °C (DT)	Suitable for filament bulb 6 or 24 V AC and 1.2 W and LED 24 V  1.5 W Ratio, see Accessories page 16:15  Class E																								



## Emergency Stop Pushbuttons with Twist, Pull or Key Release (Non-Illuminated)

Compact range



### Operator



Description	Included Blocks	Color	Key Code	Ronis Key Code	Part No.	Weight
Ø 30 mm Twist Release	1NC	Red	n/a	n/a	CE3T-10R-01	0.071 lb (0.032 kg)
	2NO	Red	n/a	n/a	CE3T-10R-20	0.071 lb (0.032 kg)
	2NC	Red	n/a	n/a	CE3T-10R-02	0.071 lb (0.032 kg)
	1NO + 1NC	Red	n/a	n/a	CE3T-10R-11	0.071 lb (0.032 kg)
Ø 30 mm Pull Release	2NC	Red	n/a	n/a	CE3P-10R-02	0.071 lb (0.032 kg)
	1NO + 1NC	Red	n/a	n/a	CE3T-10R-20	0.071 lb (0.032 kg)
Ø 30 mm Key Release	2NC	Red	71	455	CE3K1-10R-02	0.132 lb (0.060 kg)
	1NO + 1NC	Red	71	455	CE3K1-10R-11	0.132 lb (0.060 kg)
Ø 40 mm Twist Release	1NC	Red	n/a	n/a	CE4T-10R-01	0.079 lb (0.036 kg)
	2NO	Red	n/a	n/a	CE4T-10R-20	0.079 lb (0.036 kg)
	2NC	Red	n/a	n/a	CE4T-10R-02	0.079 lb (0.036 kg)
	1NO + 2NC	Red	n/a	n/a	CE4T-10R-11	0.079 lb (0.036 kg)
Ø 40 mm Pull Release	1NC + 1NO	Red	n/a	n/a	CE4T-10R-11	0.079 lb (0.036 kg)
Ø 40 mm Key Release	2NC	Red	71	455	CE4K1-10R-02	0.141 lb (0.064 kg)
	1NC + 1NO	Red	71	455	CE4K1-10R-11	0.141 lb (0.064 kg)

Packing Quantity: 1 pc

Note for Illuminated Operator: Bulb max 2 W, not included.

## Technical Data Pilot Devices, Compact Range 22 mm

<b>Standards</b>	
IEC 60947-1	Low-voltage switchgear and control-gear - Part 1: General rules
IEC 60947-5-1	Low-voltage switchgear and control-gear - Part 5-1: Control circuit devices and switching elements - Electromechanical control circuit devices
IEC 60947-5-5	Low-voltage switchgear and control-gear - Part 5-5: Control circuit devices and switching elements - Electrical emergency stop device with mechanical latching function
IEC 60073	Basic and safety principles for man-machine interface, marking and identification - Coding principles for indicators and actuators
IEC 60529	Degrees of protection provided by enclosures (IP Code)
EN 60947-1	Low-voltage switchgear and control-gear - Part 1: General rules
EN 60947-5-1	Low-voltage switchgear and control-gear - Part 5-1: Control circuit devices and switching elements - Electromechanical control circuit devices
EN 60947-5-5	Low-voltage switchgear and control-gear - Part 5-5: Control circuit devices and switching elements - Electrical emergency stop device with mechanical latching function
EN 60073	Basic and safety principles for man-machine interface, marking and identification - Coding principles for indication devices and actuators
EN 60529	Degrees of protection provided by enclosures (IP Code)
EN 50013	Low-voltage switchgear and control-gear for industrial use - Terminal marking and distinctive number for particular control switches
UL 508	Industrial Control Equipment
CSA C22.2 No 14	Industrial Control Equipment
<b>Material</b>	All front parts are made of polycarbonate.
PC Polycarbonate	High impact strength, good outdoor resistance. Can withstand light acid solutions, aliphatic hydrocarbons, paraffin, alcohols, animal and vegetable greases.
PA Polyamide	Can withstand high temperatures, aliphatic, aromatic and chlorinated hydrocarbons, esters, ketone-aldehydes, alcohols and basic solutions.
PBT	Can withstand high temperature, aliphatic and aromatic hydrocarbons, acids, basic solutions, alcohols, grease and oils.
Zinc	Good corrosion resistance in inland, sea and industrial atmosphere.
Light-alloy	Good corrosion resistance in inland, sea and industrial atmosphere.
Rubber	Chloroprene Nitrile  <i>No ozone depleting substances in the products.</i>

<b>Degrees of Protection</b>	
<b>Pilot Devices</b>	
Compact push-button, CP1, CP2, CP3, CP4	IP 66, 67, 69K UL/CSA Type 1, 3R, 4, 4X, 12, 13
Compact selector switch, C2SS, C3SS	IP 66, 67, 69K UL/CSA Type1, 3R, 4, 4X, 12, 13
Compact pilot light, CL	IP 66, 67, 69K UL/CSA Type 1, 3R, 4, 4X, 12, 13
Compact emergency stop pushbutton, CE3T, CE3P, CE4T, CE4P, CE3K1, CE4K1	IP 66, 67, 69K UL/CSA Type 1, 3R, 4, 4X, 12, 13
<b>Terminals</b>	IP 20
<b>Approvals</b>	
The pushbuttons, selector switches and pilot lights are approved by National approval agencies UL and China Compulsory Product Certification	
<i>For detail information please contact ABB.</i>	

## Technical Data Pilot Devices, Compact Range 22 mm continued

<b>Temperature</b> Ambient temperature during operation <i>Exception:</i> <i>All pilot devices with 2 W continuously lit filament bulb.</i> Storage temperature	-25 to +70 °C  -25 to +40 °C  -30 to +85 °C
<b>Tightening Torque</b> Locking nut, M22	min. 2 Nm / max. 2.3 Nm
<b>Terminals</b> Compact pushbutton Compact selector switch Compact emergency stop Connectable area  Compact pilot light Connectable area	Plus-minus Pozidriv No. 2    min. 1 x 0.5 mm <sup>2</sup> /1 x AWG 22 max. 2 x 1.5 mm <sup>2</sup> /2 x AWG14  min. 1 x 0.5 mm <sup>2</sup> /1 x AWG 20 max. 2 x 2.5 mm <sup>2</sup> /2 x AWG14
<b>Contacts</b>	<i>Self cleaning contacts of silver, NC contact with positive opening.</i>  <i>At voltages and currents below 24 V and 5.6 mA two contact blocks in parallel are recommended. As an alternative, gold plated contacts can be used.</i>
Ratings as per UL, CSA, NEMA	<b>C300</b> AC
	<b>R300</b> DC
Rated insulation voltage	250 V
Rated thermal current	2.5 A
Rated operational current	at 120 V 1.5 A at 125 V n/a at 240 V 0.75 A at 250 V n/a
	at 120 V n/a at 125 V 0.22 A at 240 V n/a at 250 V 0.11 A
Ratings as per IEC 60 947-5-1	
Rated insulation voltage, $U_i$	300 V
Rated thermal current, $I_{th}$	5 A
Rated operational current, $I_e$ utilization category AC 15	at 120 V 1.5 A at 240 V 1 A
Rated operational current, $I_e$ utilization category DC 13	at 24 V 0.3 A at 125 V 0.2 A
<b>Short circuit protection</b>	
Max. fuse at 1 kA	16 A ordinary / 10 A delayed
<b>Tightening torque</b>	
Compact pushbutton and selector switch	0.8 Nm (M3)
Compact pilot light	0.9 Nm (M3.5)
Compact emergency stop pushbutton	0.8 Nm (M3)

# Assembled Stations and Empty Plastic and Steel Enclosures

ABB Jokab Safety offers two types of assembled stations and empty enclosures —

## Plastic Enclosures

Polycarbonate enclosures with degree of protection: UL Type 1, 3R, 4, 4X, 12, 13, and IP 66, IP 67, IP 69.

## Steel Enclosures

Carbon steel or stainless steel enclosures with degree of protection: NEMA Type 1, 12, 4, 4X.



## Assembled Stations with 1-seat Plastic Enclosures

### Modular range

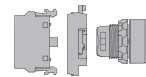

### Red Emergency Stop Pushbutton 40 mm with Twist Release

Description	Included Blocks	Enclosure Color (Upper/Lower)	Type	Weight
No Legend Plate	2 NC	Yellow/Light Grey	MEPY1-1005	0.516 lb (0.234 kg)
<i>Packing Quantity: 1 pc</i>	1NO + 2NC	Yellow/Light Grey	MEPY1-1024	0.551 lb (0.250 kg)
Emergency Stop Legend Plate	2 NC	Yellow/Light Grey	MEPY1-1026	0.516 lb (0.234 kg)
<i>Packing Quantity: 1 pc</i>				



## Assembled Stations with 2-seat Plastic Enclosures

### Modular range

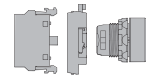

### Two Flush Pushbuttons - Red Output/Green Input

Description	Included Output	Included Input	Enclosure Color (Upper/Lower)	Type	Weight
Momentary	2 NC	1 NO	Dark Grey Light Grey	MEPY1-1005	0.516 lb (0.234 kg)
<i>Packing Quantity: 1 pc</i>					



## Assembled Stations with 1-Seat Plastic Enclosures



**Compact range**

### Plastic Enclosure for Red Emergency Stop Pushbutton

Description	Included Blocks	Enclosure Color (Upper/Lower)	Part No.	Weight
Twist Release	2 NC	Yellow/Light Grey	CEPY1-1001	0.238 lb (0.108 kg)
Pull Release	2 NC	Yellow/Light Grey	CEPY1-1002	0.238 lb (0.108 kg)

Packing Quantity: 1 pc

NEMA Type 1, 3, 3R, 4, 4X, 12, 13, and IP 66, IP 67, IP 69

### Plastic Enclosure with Shroud for Red Emergency Stop Pushbutton

Description	Included Blocks	Enclosure Color (Upper/Lower)	Part No.	Weight
Twist Release	2 NC	Yellow/Light Grey	CEPY1-2001	0.273 lb (0.124 kg)
Pull Release	2 NC	Yellow/Light Grey	CEPY1-2002	0.273 lb (0.124 kg)

Packing Quantity: 1 pc

NEMA Type 1 and IP 20

### Empty Plastic Enclosure and Shroud for Emergency Stop Pushbutton

Description	Color	Part No.	Weight
Empty Enclosure	Yellow/Light Grey	CEPY1-0	0.159 lb (0.072 kg)
Shroud	Yellow	CA1-8053	0.035 lb (0.016 kg)

Packing Quantity: 1 pc

NEMA Type 1 and IP 20

### Plastic Enclosure for Black Mushroom Machine Stop Pushbutton

Description	Included Blocks	Enclosure Color (Upper/Lower)	Part No.	Weight
Twist Release	1NO + 1NC	Dark Grey/Light Grey	CEP1-1001	0.238 lb (0.108 kg)
Pull Release	1NO + 1NC	Dark Grey/Light Grey	CEP1-1002	0.238 lb (0.108 kg)

Packing Quantity: 1 pc

NEMA Type 1, 3, 3R, 4, 4X, 12, 13, and IP 66, IP 67, IP 69

### Plastic Enclosure with Shroud for Black Mushroom Machine Stop Pushbutton

Description	Included Blocks	Enclosure Color (Upper/Lower)	Part No.	Weight
Twist Release	1NO + 1NC	Dark Grey/Light Grey	CEP1-2001	0.273 lb (0.124 kg)
Pull Release	1NO + 1NC	Dark Grey/Light Grey	CEP1-2002	0.273 lb (0.124 kg)

Packing Quantity: 1 pc

NEMA Type 1 and IP 20

### Empty Plastic Enclosure and Shroud for Machine Stop Pushbutton

Description	Color	Part No.	Weight
Empty Enclosure	Dark Grey/Light Grey	CEP1-0	0.159 lb (0.072 kg)
Shroud	Grey	CA1-8054	0.035 lb (0.016 kg)

Packing Quantity: 1 pc

NEMA Type 1 and IP 20

# Empty Plastic Enclosures Degree of Protection - IP 66

## WHEN ORDERING:

- Select operators in the Modular Range from page 16:6 through 16:9—or from the Compact Range from page 21.
- Select contact blocks for rear mounting from the chart below and on the following page and lamp blocks for rear mounting from pages 16:12.
- Select accessories from pages 16:11 through 16:16.  
*Note: For rear mounted pilot devices, one spacer per operator has to be ordered if legend plate is not used.*
- Specify holes for cable glands.  
*1-seat, 2-seat, 3-seat enclosures: M20 and Pg 13.5/Pg16 and (M20)  
4-seat and 6-seat enclosures: M25/Pg16 and (M20)*

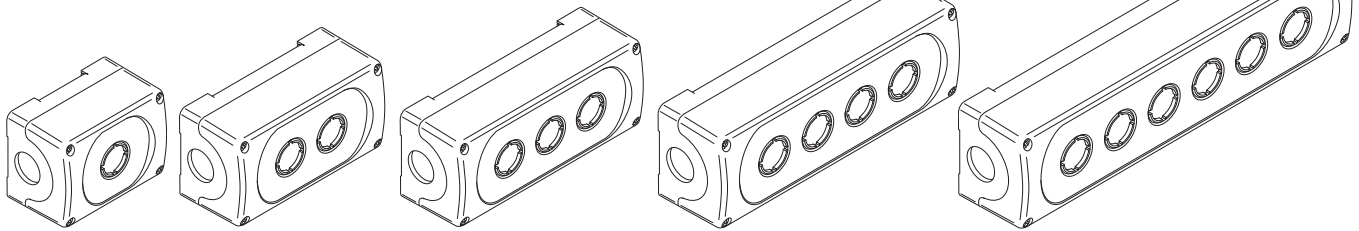
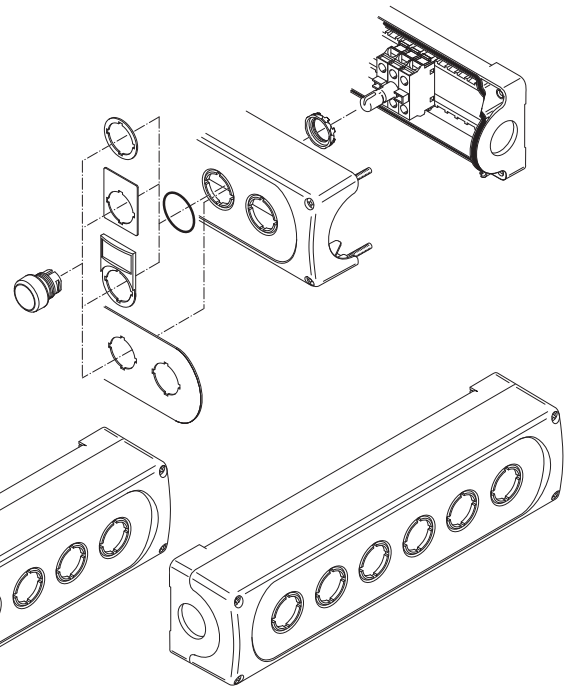

Description	Color (Upper/Lower)	Part No.	Weight
with 1-seat	Dark Grey/Light Grey	MEP1-0	0.331 lb (0.150 kg)
	Yellow/Light Grey	MEPY1-0	0.331 lb (0.150 kg)
with 3-seat	Dark Grey/Light Grey	MEP3-0	0.441 lb (0.200 kg)
with 4-seat	Dark Grey/Light Grey	MEP4-0	0.507 lb (0.230 kg)
with 6-seat	Dark Grey/Light Grey	MEP6-0	0.661 lb (0.300 kg)

Provided with stainless steel screws. Note: UL-listed for end of line use only.

## Accessories for Plastic Enclosures

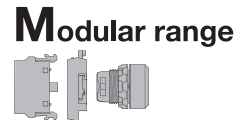

### Contact Blocks (Rear Mounting)

Description	Included Blocks	Part No.	Weight
Contact Blocks <i>Packing Quantity: 10 pcs</i>	1NO	MCB-10B	0.029 lb (0.013 kg)
	1NC	MCB-01B	0.029 lb (0.013 kg)
Double Contact Blocks <i>Packing Quantity: 10 pcs</i>	2NC	MCB-20B	0.057 lb (0.026 kg)
	2NC	MCB-02B	0.057 lb (0.026 kg)
	1NO + 1NC	MCB-11B	0.057 lb (0.026 kg)
Contact Blocks with Gold Plated Contacts <i>Packing Quantity: 10 pcs</i>	1NO	MCB-10BG	0.029 lb (0.013 kg)
	1NC	MCB-01BG	0.029 lb (0.013 kg)

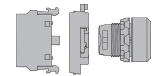

## Accessories for Plastic Enclosures

### Lamp Blocks (Rear Mounting)

Description	Diagram	Part No.	Weight
max. 2 W, 230 V AC/DC filament bulb or LED		MLB-1B	0.033 lb (0.015 kg)
max. 1.2 W, 115 V AC 60 V filament bulb		MLB-2B	0.037 lb (0.017 kg)
max. 2 W, 230 V AC 130 V filament bulb <i>Packing Quantity: 10 pcs</i>		MLB-3B	0.037 lb (0.017 kg)

### Protective Sleeve, Cable Gland and Nut

Description	Cable	Part No.	Weight
Sleeve makes a rear-mounted lamp block screen protected. IP20 <i>Packing Quantity: 10 pcs</i>	n/a	5396 0543-1	0.004 lb (0.002 kg)
<i>Not together with illuminated selector switch.</i>			
Grey plastic Cable Gland with threaded outer sleeve. Sealing ring included. <i>Packing Quantity: 10 pcs</i>	M25	MA5-3001	0.033 lb (0.015 kg)
	M20	MA5-3002	0.033 lb (0.015 kg)
	PG 13.5	MA5-3006	0.022 lb (0.010 kg)
	PG 16	MA5-3007	0.033 lb (0.015 kg)
Grey plastic Nut for Cable Gland <i>Packing Quantity: 10 pcs</i>	M25	MA5-3003	0.011 lb (0.005 kg)
	M20	MA5-3004	0.011 lb (0.005 kg)
	PG 13.5	MA5-3008	0.002 lb (0.001 kg)
	PG 16	MA5-3009	0.002 lb (0.001 kg)

### Ground Block

Description	Part No.	Weight
For Plastic Enclosures <i>Packing Quantity: 10 pcs</i>	MA5-3005	0.011 lb (0.005 kg)

### Spacer

Description	Part No.	Weight
Spacer, 1 mm thick, needed when legend plates are not used in plastic enclosures <i>Packing Quantity: 10 pcs</i>	SK 615 516-1	0.004 lb (0.002 kg)
	KA1-8045*	0.009 lb (0.004 kg)

*\*For Modular Emergency Stop Pushbutton, page 16:9 - 16:11.*

### Blanking Plug and Adapter

Description	Color	Part No.	Weight
Blanking Plug <i>Packing Quantity: 10 pcs Gasket and nut included.</i>	Grey	MA1-8129	0.011 lb (0.005 kg)
	Black	MA1-8130	0.011 lb (0.005 kg)
Adapter <i>Packing Quantity: 10 pcs</i>	n/a	MA5-3010	0.022 lb (0.010 kg)

## Assembled Stations with 1-Seat Steel Enclosures, 22 mm

E_STOP	Position 1	Position 2	Position 3	Position 4	Type 12 Part No.	Type 4X Stainless Part No
Type	40 mm Twist	n/a	n/a	n/a	MEM121-ES	MEMX1-ES
Color	Red					
Contacts	2 NC					
Name Plate	EMER. STOP					
E-STOP Illuminated	Position 1	Position 2	Position 3	Position 4	Type 12 Part No.	Type 4X Stainless Part No.
Type	40 mm Twist	n/a	n/a	n/a	MEM121-1ES	MEMX1-1ES
Color	Red Illuminated					
Contacts	2 NC					
Lamp	120V LED					
Name Plate	EMER. STOP					

## Assembled Stations with 2-Seat Steel Enclosures, 22 mm

START, STOP	Position 1	Position 2	Position 3	Position 4	Type 12 Part No.	Type 4X Stainless Part No
Type	Mom, extend.	Mom, flush	n/a	n/a	MEM122-SS	MEMX2-SS
Color	Red	Green				
Contacts	1 NO + 1 NC	1 NO + 1 NC				
Name Plate	STOP	START				
HOA, RUN LIGHT	Position 1	Position 2	Position 3	Position 4	Type 12 Part No.	Type 4X Stainless Part No.
Type	3-pos, maint.	Pilot light	n/a	n/a	MEM122-1HOARL	MEMX2-1HOARL
Color	Black	Red				
Contacts	2 NO	120V LED				
Name Plate	Hand O Auto	Run				

## Assembled Stations with 3-Seat Steel Enclosures, 22 mm

START, STOP, RUN LIGHT	Position 1	Position 2	Position 3	Position 4	Type 12 Part No.	Type 4X Stainless Part No
Type	Mom, extend.	Mom, flush	Pilot light	n/a	MEM123-1SSRL	MEMX3-1SSRL
Color	Red	Green	Red			
Contacts	1 NO + 1 NC	1 NO + 1 NC	120V LED			
Name Plate	STOP	START	Run			
START, STOP, E-STOP	Position 1	Position 2	Position 3	Position 4	Type 12 Part No.	Type 4X Stainless Part No.
Type	40 mm Twist	Mom, extend.	Mom, flush	n/a	MEM123-SSSES	MEMX3-SSSES
Color	Red	Red	Green			
Contacts	2 NC	1 NO + 1 NC	1 NO + 1 NC			
Name Plate	EMER. STOP	STOP	START			



## 4-Seat Steel Enclosures/Assembled Stations, 22 mm

START, STOP, E-STOP, RUN LIGHT	Position 1	Position 2	Position 3	Position 4	Type 12 Part No.	Type 4X Stainless Part No
Type	40 mm Twist	Mom, extend	Mom, flush	Pilot light	MEM124-1ESSRL	MEMX4-1ESSRL
Color	Red	Red	Green	Red		
Contacts	2 NC	1 NO + 1 NC	1 NO + 1 NC	120V LED		
Name Plate	EMER. STOP	STOP	START	Run		

## Empty Steel Enclosures, 22 mm

### NEMA 12, 0.075" Carbon Steel, ANSI-61 Gray

Description	Height	Width	Depth	Part No.
1-hole	3.50	3.25	2.75	MEM121-0
2-hole	5.75	3.25	2.75	MEM122-0
3-hole	8.00	3.25	2.75	MEM123-0
4-hole	10.25	3.25	2.75	MEM124-0
6-hole, 2x3	9.50	6.25	3.00	MEM126-0



MEM121-0

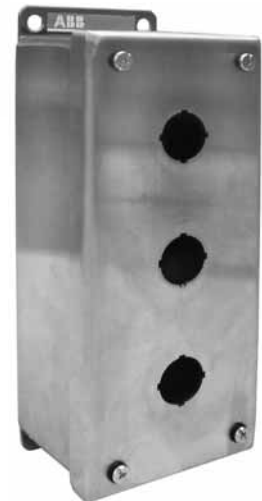

MEMX3-0

### NEMA 4X, Stainless Steel, Brushed Finish

Description	Height	Width	Depth	Part No.
1-hole	3.50	3.25	2.75	MEMX1-0
2-hole	5.75	3.25 <td 2.75	MEMX2-0	
3-hole	8.00	3.25	2.75	MEMX3-0
4-hole	10.25	3.25	2.75	MEMX4-0
6-hole, 2x3	9.50	6.25	3.00	MEMX6-0

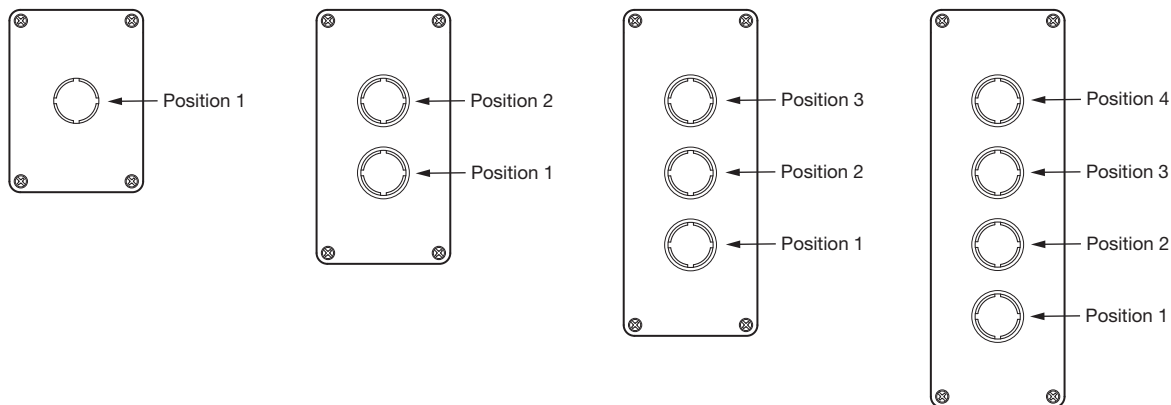

# Signal Towers K70

## Simple Fitting with Quick Fix System

Each K 70 module is equipped with a bayonet fixing with integral contact system. The modules are fastened together by aligning the corresponding white marks then with a gentle twist they are locked into place. See the figures at the right.



## Connection Plans

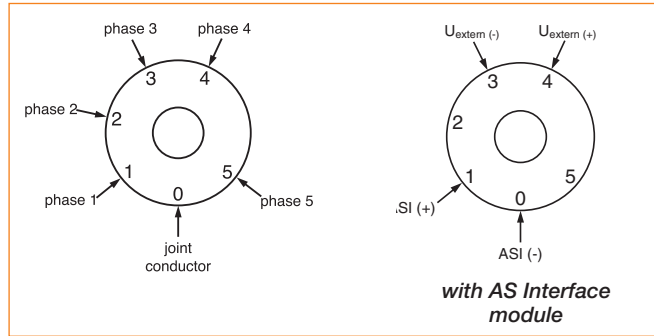



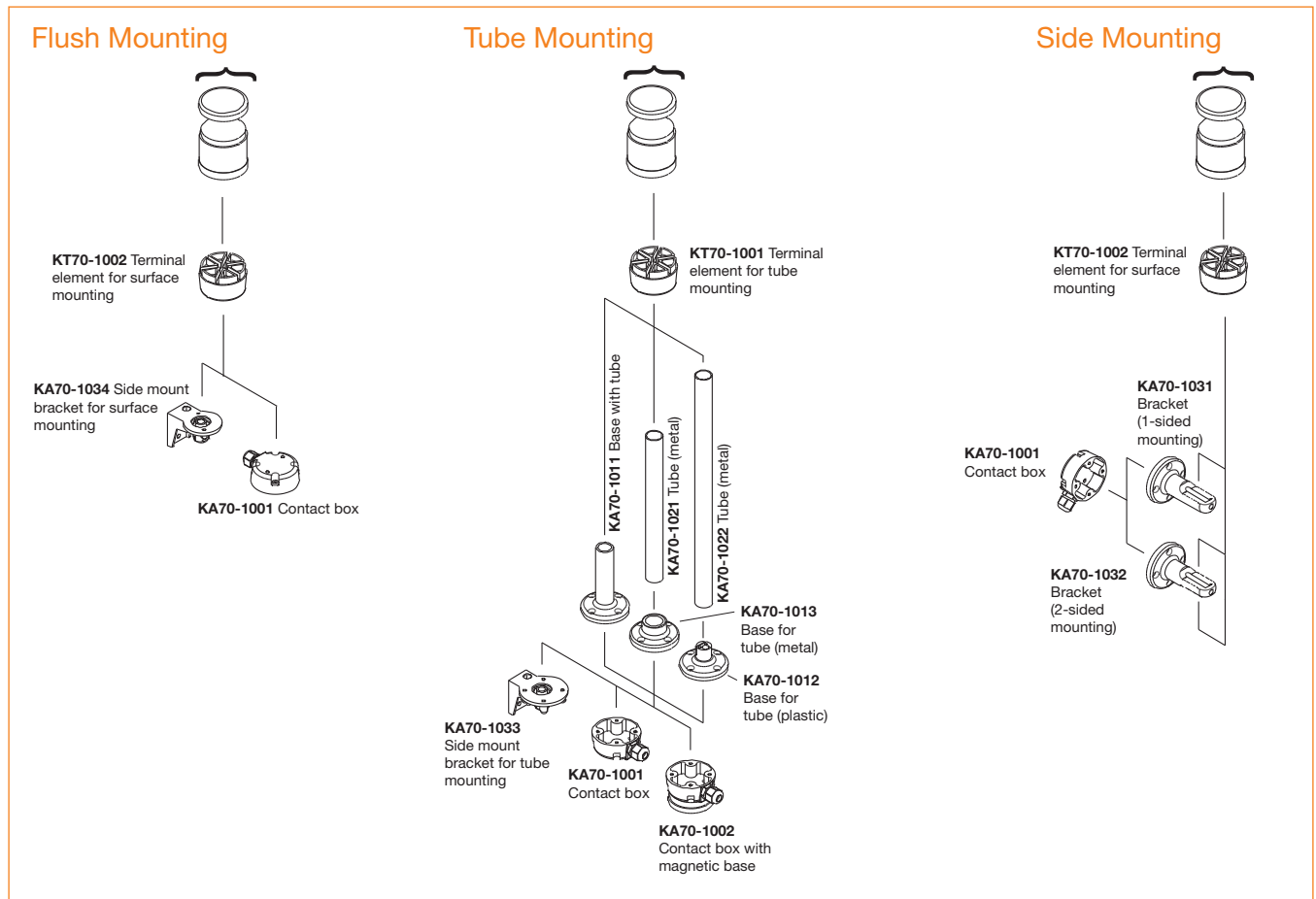

Stackable elements	5 max
Audible modules	
Buzzer	KB70
Siren	KS70
AS-Interface module	KASI
Light element	KL70
Cap	included with terminal element

## Combination Possibilities







# Signal Towers K60

## Optical Modules

Light Element		Rated Voltage	Color	Part No.
<b>Permanent Light</b> <i>For bulb BA15d.</i> <i>Bulb not included.</i>		12-240 V AC/DC	Red	KL70-401R
		12-240 V AC/DC	Green	KL70-401G
		12-240 V AC/DC	Yellow	KL70-401Y
		12-240 V AC/DC	Blue	KL70-401L
		12-240 V AC/DC	Clear	KL70-401C
<b>Permanent Light</b> <i>LED included.</i> <i>Not changeable.</i>		24 V AC/DC	Red	KL70-305R
		24 V AC/DC	Green	KL70-305G
		24 V AC/DC	Yellow	KL70-305Y
		24 V AC/DC	Blue	KL70-305L
		24 V AC/DC	Clear	KL70-305C
<b>Blinking Light</b> <i>With integrated LED.</i> <i>Not changeable.</i>		24 V AC/DC	Red	KL70-306R
		24 V AC/DC	Green	KL70-306G
		24 V AC/DC	Yellow	KL70-306Y
		24 V AC/DC	Blue	KL70-306L
		24 V AC/DC	Clear	KL70-306C
		115 V AC/DC	Red	KL70-342R
		115 V AC/DC	Green	KL70-342G
		115 V AC/DC	Yellow	KL70-342Y
		115 V AC/DC	Blue	KL70-342L
		115 V AC/DC	Clear	KL70-342C
		230 V AC/DC	Red	KL70-352R
		230 V AC/DC	Green	KL70-352G
		230 V AC/DC	Yellow	KL70-352Y
		230 V AC/DC	Blue	KL70-352L
		230 V AC/DC	Clear	KL70-352C
<b>Flashing Light</b> <i>Xenon tube included.</i> <i>Not changeable.</i>		24 V DC	Red	KL70-203R
		24 V DC	Green	KL70-203G
		24 V DC	Yellow	KL70-203Y
		24 V DC	Blue	KL70-203L
		24 V DC	Clear	KL70-203C
		115 V AC	Red	KL70-113R
		115 V AC	Green	KL70-113G
		115 V AC	Yellow	KL70-113Y
		115 V AC	Blue	KL70-113L
		115 V AC	Clear	KL70-113C
		230 V AC	Red	KL70-123R
		230 V AC	Green	KL70-123G
		230 V AC	Yellow	KL70-123Y
		230 V AC	Blue	KL70-123L
		230 V AC	Clear	KL70-123C
<b>Rotating Light</b> <i>LED included.</i> <i>Not changeable.</i>		24 V AC/DC	Red	KL70-307R
		24 V AC/DC	Green	KL70-307G
		24 V AC/DC	Yellow	KL70-307Y
		24 V AC/DC	Blue	KL70-305L
		24 V AC/DC	Clear	KL70-305C

## Signal Towers K60 Accessories

Bulbs		Description		Part No.
Bulb BA 15d		42 mm, max 7 W For permanent or blinking light. 2000 hour life.	24 V, 5 W, AC/DC	KLB24
			115 V, 5 W, AC/DC	KLB1
			230 V, 5 W, AC/DC	KLB2
LED bulbs Ba 15d.		For 24 V AC/DC, 40 mA.	Red	KA4-1021
			Green	KA4-1022
			Yellow	KA4-1023
			Blue	KA4-1024
			White	KA4-1025

Audible Modules		Description		Part No.
Buzzer Element		85 dB, continuous or pulsating tone, adjustable, 8mA	24 V AC/DC	KB70-3001
			115 V AC/DC	KB70-3101
			230 V AC	KB70-1201
Siren Element		Multi function, 8 different tones adjustable, volume adjustable 100 dB	115 V AC, 40 mA	KS70-1104
			230 V AC, 40 mA	KS70-1204
			100 dB, 24 VDC, 100 mA	KS70-2004
			24 VAC/DC, 80 mA	KS70-3004
			Continuous tone alternating	108 dB, 24 VDC, 100 mA

AS-Interface Module		Description		Part No.
		For external voltage	18.5-31.6 VAC/DC	KASI-4101

Terminal Elements		Description		Part No.
		For tube mounting, including cap		KT70-1001
		For bracket or base, including cap		KT70-1002

Special Parts		Description		Part No.
Contact Box		Cable exit at side		KA70-1001
		Magnetic base		KA70-1002
Base with Tube		D = 25 mm, L = 110 mm		KA70-1011
Base for Tube		D = 25 mm, Plastic		KA70-1012
		D = 25 mm, Metal		KA70-1013
Tube, anodized aluminum		D = 25 mm, L = 250 mm		KA70-1021
		D = 25 mm, L = 400 mm		KA70-1022
Bracket		1-sided mounting		KA70-1031
		2-sided mounting		KA70-1032
		For tube mounting		KA70-1033
		For surface mounting		KA70-1034

## Technical Data Signal Towers K70

<b>Material</b> Housing and Accessories Dome	Polyamide, high impact, black Polycarbonate, transparent		
<b>Fixing</b>	Base mounting Tube mounting, for tube $\varnothing$ 25 mm Bracket mounting		
<b>Socket</b>	B 15 d, for bulb max. 7W		
<b>Connection</b>	Screwable connection up to 2.5 mm <sup>2</sup>		
<b>Number of modules possible</b> 2-sided bracket	max. 5 max.10 elements		
<b>Degrees of Protection</b> Light elements Audible elements	IP 54 / UL Type 5 IP 54 / UL Type 5		
<b>Electrical Data</b> <b>Permanent light element</b> Bulb socket B 15 d, max 7 W	12 - 240 V AC/DC Bulb not included		
<b>Blinking light element</b>	24 V AC/DC	115 V AC/DC	230 V AC/DC
Starting current	Bulb not included < 0.5 A		
<b>Flashing light element</b>	24 V DC	115 V AC	230 V AC
Flash frequency	1 Hz	1 Hz	1 Hz
Flash energy	2 Ws	2 Ws	2 Ws
Life duration	4 x 10 <sup>6</sup> flashes		
Current consumption	125 mA	20 mA	35 mA
reduced for AS-Interface	80 mA		
Starting current	< 0.5 A at 24 V		
<b>LED Permanent light element</b>	24 V AC/DC		
Current consumption	45 mA		
Starting current	< 0.5 A at 24 V		
<b>LED Blinking light element</b>	24 V AC/DC		
Current consumption	25 mA		
Starting current	< 0.5 A at 24 V		
Blink frequency	c. 1 Hz	c. 1Hzc.	1 Hz
<b>LED Rotating light element</b>	24 V AC/DC		
Current consumption	70 mA		
Starting current	< 0.5 A at 24 V		
Rotation frequency	c. 120 r.p.m.		
<b>Temperature</b> Ambient temperature during operations	-20 to +50 °C		
<b>Approvals</b>			

## Notes

This document and any attachments may include suggested specifications, drawings, schematics and similar materials from ABB Inc. Use of such information and/or documentation by the recipient is subject to and conditioned upon your acceptance of the terms of the General Document Disclaimer which can be found at [www.jokabsafety.com](http://www.jokabsafety.com). Your acceptance of the terms of such General Document Disclaimer is conclusively presumed unless you notify ABB in writing of your disagreement with the terms of such Disclaimer immediately upon receipt of this document and you return to ABB all specifications, drawings, schematics and similar materials provided to you by ABB.

## ABB General Terms and Conditions of Sale

1. General. The terms and conditions contained herein, together with any additional or different terms contained in ABB's Proposal, if any, submitted to Purchaser (which Proposal shall control over any conflicting terms), constitute the entire agreement (the "Agreement") between the parties with respect to the order and supersede all prior communications and agreements regarding the order. Acceptance by ABB of the order, or Purchaser's acceptance of ABB's Proposal, is expressly limited to and conditioned upon Purchaser's acceptance of these terms and conditions, payment for or acceptance of any performance by ABB being acceptance. These terms and conditions may not be changed or superseded by any different or additional terms and conditions proposed by Purchaser to which terms ABB hereby objects. Unless the context otherwise requires, the term "Equipment" as used herein means all of the equipment, parts, accessories sold, and all software and software documentation, if any, licensed to Purchaser by ABB ("Software") under the order. Unless the context otherwise requires, the term "Services" as used herein means all labor, supervisory, technical and engineering, installation, repair, consulting or other services provided by ABB under the order. As used herein, the term "Purchaser" shall include the initial end user of the Equipment and/or services; provided, however, that Paragraph 13(a) shall apply exclusively to the initial end user.

### 2. Prices.

- (a) Unless otherwise specified in writing, all Proposals expire thirty (30) days from the date thereof.
- (b) Unless otherwise stated herein, Services prices are based on normal business hours (8 a.m. to 5 p.m. Monday through Friday). Overtime and Saturday hours will be billed at one and one-half (1 1/2) times the hourly rate; and Sunday hours will be billed at two (2) times the hourly rate; holiday hours will be billed at three (3) times the hourly rate. If a Services rate sheet is attached hereto, the applicable Services rates shall be those set forth in the rate sheet. Rates are subject to change without notice.
- (c) The price does not include any federal, state or local property, license, privilege, sales, use, excise, gross receipts, or other like taxes which may now or hereafter be applicable. Purchaser agrees to pay or reimburse any such taxes which ABB or its suppliers are required to pay or collect. If Purchaser is exempt from the payment of any tax or holds a direct payment permit, Purchaser shall, upon order placement, provide ABB a copy, acceptable to the relevant governmental authorities of any such certificate or permit.
- (d) The price includes customs duties and other importation or exportation fees, if any, at the rates in effect on the date of ABB's Proposal. Any change after that date in such duties, fees, or rates, shall increase the price by ABB's additional cost.

### 3. Payment.

- (a) Unless specified to the contrary in writing by ABB, payment terms are net cash, payable without offset, in United States Dollars, 30 days from date of invoice by wire transfer to the account designated by ABB in the Proposal.
- (b) If in the judgment of ABB the financial condition of Purchaser at any time prior to delivery does not justify the terms of payment specified, ABB may require payment in advance, payment security satisfactory to ABB, or may terminate the order, whereupon ABB shall be entitled to receive reasonable cancellation charges. If delivery is delayed by Purchaser, payment shall be due on the date ABB is prepared to make delivery. Delays in delivery or nonconformities in any installments delivered shall not relieve Purchaser of its obligation to accept and pay for remaining installments.

(c) Purchaser shall pay, in addition to the overdue payment, a late charge equal to the lesser of 1 1/2% per month or any part thereof or the highest applicable rate allowed by law on all such overdue amounts plus ABB's attorneys' fees and court costs incurred in connection with collection.

### 4. Changes.

- (a) Any changes requested by Purchaser affecting the ordered scope of work must be accepted by ABB and resulting adjustments to affected provisions, including price, schedule, and guarantees mutually agreed in writing prior to implementation of the change.
- (b) ABB may, at its expense, make such changes in the Equipment or Services as it deems necessary, in its sole discretion, to conform to the Equipment or Services to the applicable specifications. If Purchaser objects to any such changes, ABB shall be relieved of its obligation to conform to the applicable specifications to the extent that conformance may be affected by such objection.

### 5. Delivery.

- (a) All Equipment manufactured, assembled or warehoused in the continental United States is delivered F.O.B. point of shipment. Equipment shipped from outside the continental United States is delivered F.O.B. United States port of entry. Purchaser shall be responsible for any and all demurrage or detention charges.
- (b) If the scheduled delivery of Equipment is delayed by Purchaser or by Force Majeure, ABB may move the Equipment to storage for the account of and at the risk of Purchaser whereupon it shall be deemed to be delivered.
- (c) Shipping and delivery dates are contingent upon Purchaser's timely approvals and delivery by Purchaser of any documentation required for ABB's performance hereunder.
- (d) Claims for shortages or other errors in delivery must be made in writing to ABB within ten days of delivery. Equipment may not be returned except with the prior written consent of and subject to terms specified by ABB. Claims for damage after delivery shall be made directly by Purchaser with the common carrier.

6. Title & Risk of Loss. Except with respect to Software (for which title shall not pass, use being licensed) title to Equipment shall remain in ABB until fully paid for. Notwithstanding any agreement with respect to delivery terms or payment of transportation charges, risk of loss or damage shall pass to Purchaser upon delivery.

### 7. Inspection, Testing and Acceptance.

- (a) Any inspection by Purchaser of Equipment on ABB's premises shall be scheduled in advance to be performed during normal working hours.
- (b) If the order provides for factory acceptance testing, ABB shall notify Purchaser when ABB will conduct such testing prior to shipment. Unless Purchaser states specific objections in writing within ten (10) days after completion of factory acceptance testing, completion of the acceptance test constitutes Purchaser's factory acceptance of the Equipment and its authorization for shipment.
- (c) If the order provides for site acceptance testing, testing will be performed by ABB personnel to verify that the Equipment has arrived at site complete, without physical damage, and in good operating condition. Completion of site acceptance testing constitutes full and final acceptance of the Equipment. If, through no fault of ABB, acceptance testing is not completed within thirty (30) days after arrival of the Equipment at the site, the site acceptance test shall be deemed completed and the Equipment shall be deemed accepted.

## ABB General Terms and Conditions of Sale

### 8. Warranties and Remedies.

(a) Equipment and Services Warranty. ABB warrants that Equipment (excluding Software, which is warranted as specified in paragraph (d) below) shall be delivered free of defects in material and workmanship and that Services shall be free of defects in workmanship. The Warranty Remedy Period for Equipment (excluding Software, Spare Parts and Refurbished or Repaired Parts) shall end twelve (12) months after installation or eighteen (18) months after date of shipment, whichever first occurs. The Warranty Remedy Period for new spare parts shall end twelve (12) months after date of shipment. The Warranty Remedy Period for refurbished or repaired parts shall end ninety (90) days after date of shipment. The Warranty Remedy Period for Services shall end ninety (90) days after the date of completion of Services.

(b) Equipment and Services Remedy. If a nonconformity to the foregoing warranty is discovered in the Equipment or Services during the applicable Warranty Remedy Period, as specified above, under normal and proper use and provided the Equipment has been properly stored, installed, operated and maintained and written notice of such nonconformity is provided to ABB promptly after such discovery and within the applicable Warranty Remedy Period, ABB shall, at its option, either (i) repair or replace the nonconforming portion of the Equipment or re-perform the nonconforming Services or (ii) refund the portion of the price applicable to the nonconforming portion of Equipment or Services. If any portion of the Equipment or Services so repaired, replaced or re-performed fails to conform to the foregoing warranty, and written notice of such nonconformity is provided to ABB promptly after discovery and within the original Warranty Remedy Period applicable to such Equipment or Services or 30 days from completion of such repair, replacement or re-performance, whichever is later, ABB will repair or replace such nonconforming Equipment or re-perform the nonconforming Services. The original Warranty Remedy Period shall not otherwise be extended.

(c) Exceptions. ABB shall not be responsible for providing working access to the nonconforming Equipment, including disassembly and re assembly of non-ABB supplied equipment, or for providing transportation to or from any repair facility, all of which shall be at Purchaser's risk and expense. ABB shall have no obligation hereunder with respect to any Equipment which (i) has been improperly repaired or altered; (ii) has been subjected to misuse, negligence or accident; (iii) has been used in a manner contrary to ABB's instructions; (iv) is comprised of materials provided by or a design specified by Purchaser; or (v) has failed as a result of ordinary wear and tear. Equipment supplied by ABB but manufactured by others is warranted only to the extent of the manufacturer's warranty, and only the remedies, if any, provided by the manufacturer will be allowed.

(d) Software Warranty and Remedies. ABB warrants that, except as specified below, the Software will, when properly installed, execute in accordance with ABB's published specification. If a nonconformity to the foregoing warranty is discovered during the period ending one (1) year after the date of shipment and written notice of such nonconformity is provided to ABB promptly after such discovery and within that period, including a description of the nonconformity and complete information about the manner of its discovery, ABB shall correct the nonconformity by, at its option, either (i) modifying or making available to the Purchaser instructions for modifying the Software; or (ii) making available at ABB's facility necessary corrected or replacement programs. ABB shall have no obligation with respect to any nonconformities resulting from (i) unauthorized modification of the Software or (ii) Purchaser-supplied software or inter-

facing. ABB does not warrant that the functions contained in the software will operate in combinations which may be selected for use by the Purchaser, or that the software products are free from errors in the nature of what is commonly categorized by the computer industry as "bugs".

(e) THE FOREGOING WARRANTIES ARE EXCLUSIVE AND IN LIEU OF ALL OTHER WARRANTIES OF QUALITY AND PERFORMANCE, WHETHER WRITTEN, ORAL OR IMPLIED, AND ALL OTHER WARRANTIES INCLUDING ANY IMPLIED WARRANTIES OF MERCHANTABILITY OR FITNESS FOR A PARTICULAR PURPOSE OR USAGE OF TRADE ARE HEREBY DISCLAIMED. THE REMEDIES STATED HEREIN CONSTITUTE PURCHASER'S EXCLUSIVE REMEDIES AND ABB'S ENTIRE LIABILITY FOR ANY BREACH OF WARRANTY.

### 9. Patent Indemnity.

(a) ABB shall defend at its own expense any action brought against Purchaser alleging that the Equipment or the use of the Equipment to practice any process for which such Equipment is specified by ABB (a "Process") directly infringes any claim of a patent of the United States of America and to pay all damages and costs finally awarded in any such action, provided that Purchaser has given ABB prompt written notice of such action, all necessary assistance in the defense thereof and the right to control all aspects of the defense thereof including the right to settle or otherwise terminate such action in behalf of Purchaser.

(b) ABB shall have no obligation hereunder and this provision shall not apply to: (i) any other equipment or processes, including Equipment or Processes which have been modified or combined with other equipment or process not supplied by ABB; (ii) any Equipment or Process supplied according to a design, other than an ABB design, required by Purchaser; (iii) any products manufactured by the Equipment or Process; (iv) any patent issued after the date hereof; or (v) any action settled or otherwise terminated without the prior written consent of ABB.

(c) If, in any such action, the Equipment is held to constitute an infringement, or the practice of any Process using the Equipment is finally enjoined, ABB shall, at its option and its own expense, procure for Purchaser the right to continue using said Equipment; or modify or replace it with non infringing equipment or, with Purchaser's assistance, modify the Process so that it becomes non infringing; or remove it and refund the portion of the price allocable to the infringing Equipment. THE FOREGOING PARAGRAPHS STATE THE ENTIRE LIABILITY OF ABB AND EQUIPMENT MANUFACTURER FOR ANY PATENT INFRINGEMENT.

(d) To the extent that said Equipment or any part thereof is modified by Purchaser, or combined by Purchaser with equipment or processes not furnished hereunder (except to the extent that ABB is a contributory infringer) or said Equipment or any part thereof is used by Purchaser to perform a process not furnished hereunder by ABB or to produce an article, and by reason of said modification, combination, performance or production, an action is brought against ABB, Purchaser shall defend and indemnify ABB in the same manner and to the same extent that ABB would be obligated to indemnify Purchaser under this "Patent Indemnity" provision.



## ABB General Terms and Conditions of Sale

### 10. Limitation of Liability.

(a) In no event shall ABB, its suppliers or subcontractors be liable for special, indirect, incidental or consequential damages, whether in contract, warranty, tort, negligence, strict liability or otherwise, including, but not limited to, loss of profits or revenue, loss of use of the Equipment or any associated equipment, cost of capital, cost of substitute equipment, facilities or services, downtime costs, delays, and claims of customers of the Purchaser or other third parties for any damages. ABB's liability for any claim whether in contract, warranty, tort, negligence, strict liability, or otherwise for any loss or damage arising out of, connected with, or resulting from this Agreement or the performance or breach thereof, or from the design, manufacture, sale, delivery, resale, repair, replacement, installation, technical direction of installation, inspection, operation or use of any equipment covered by or furnished under this Agreement, or from any services rendered in connection therewith, shall in no case (except as provided in the section entitled "Patent Indemnity") exceed one-half (1/2) of the purchase price allocable to the Equipment or part thereof or Services which gives rise to the claim.

(b) All causes of action against ABB arising out of or relating to this Agreement or the performance or breach hereof shall expire unless brought within one year of the time of accrual thereof.

(c) In no event, regardless of cause, shall ABB be liable for penalties or penalty clauses of any description or for indemnification of Purchaser or others for costs, damages, or expenses arising out of or related to the Equipment and/Services.

11. Laws and Regulations. ABB does not assume any responsibility for compliance with federal, state or local laws and regulations, except as expressly set forth herein, and compliance with any laws and regulations relating to the operation or use of the Equipment or Software is the sole responsibility of the Purchaser. All laws and regulations referenced herein shall be those in effect as of the Proposal date. In the event of any subsequent revisions or changes thereto, ABB assumes no responsibility for compliance therewith. If Purchaser desires a modification as a result of any such change or revision, it shall be treated as a change per Article 4. Nothing contained herein shall be construed as imposing responsibility or liability upon ABB for obtaining any permits, licenses or approvals from any agency required in connection with the supply, erection or operation of the Equipment. This Agreement shall be governed by the laws of the State of New York, but excluding the provisions of the United Nations Convention on Contracts for the International Sale of Goods and excluding New York law with respect to conflicts of law. Purchaser agrees that all causes of action against ABB under this Agreement shall be brought in the State Courts of the State of New York, or the U.S. District Court for the Southern District of New York. If any provision hereof, partly or completely, shall be held invalid or unenforceable, such invalidity or unenforceability shall not affect any other provision or portion hereof and these terms shall be construed as if such invalid or unenforceable provision or portion thereof had never existed.

12. OSHA. ABB warrants that the Equipment will comply with the relevant standards of the Occupational Safety and Health Act of 1970 ("OSHA") and the regulations promulgated thereunder as of the date of the Proposal. Upon prompt written notice from the Purchaser of a breach of this warranty, ABB will replace the affected part or modify it so that it conforms to such standard or regulation. ABB's obligation shall be limited to such replacement or modification. In no event shall ABB be responsible for liability arising

out of the violation of any OSHA standards relating to or caused by Purchaser's design, location, operation, or maintenance of the Equipment, its use in association with other equipment of Purchaser, or the alteration of the Equipment by any party other than ABB.

### 13. Software License.

(a) ABB owns all rights in or has the right to sublicense all of the Software, if any, to be delivered to Purchaser under this Agreement. As part of the sale made hereunder Purchaser hereby obtains a limited license to use the Software, subject to the following: (i) The Software may be used only in conjunction with equipment specified by ABB; (ii) The Software shall be kept strictly confidential; (iii) The Software shall not be copied, reverse engineered, or modified; (iv) The Purchaser's right to use the Software shall terminate immediately when the specified equipment is no longer used by the Purchaser or when otherwise terminated, e.g. for breach, hereunder; and (v) the rights to use the Software are non-exclusive and non-transferable, except with ABB's prior written consent.

(b) Nothing in this Agreement shall be deemed to convey to Purchaser any title to or ownership in the Software or the intellectual property contained therein in whole or in part, nor to designate the Software a "work made for hire" under the Copyright Act, nor to confer upon any person who is not a named party to this Agreement any right or remedy under or by reason of this Agreement. In the event of termination of this License, Purchaser shall immediately cease using the Software and, without retaining any copies, notes or excerpts thereof, return to ABB the Software and all copies thereof and shall remove all machine readable Software from all of Purchaser's storage media.

14. Inventions and Information. Unless otherwise agreed in writing by ABB and Purchaser, all right, title and interest in any inventions, developments, improvements or modifications of or for Equipment and Services shall remain with ABB. Any design, manufacturing drawings or other information submitted to the Purchaser remains the exclusive property of ABB. Purchaser shall not, without ABB's prior written consent, copy or disclose such information to a third party. Such information shall be used solely for the operation or maintenance of the Equipment and not for any other purpose, including the duplication thereof in whole or in part.

15. Force Majeure. ABB shall neither be liable for loss, damage, detention or delay nor be deemed to be in default for failure to perform when prevented from doing so by causes beyond its reasonable control including but not limited to acts of war (declared or undeclared), Acts of God, fire, strike, labor difficulties, acts or omissions of any governmental authority or of Purchaser, compliance with government regulations, insurrection or riot, embargo, delays or shortages in transportation or inability to obtain necessary labor, materials, or manufacturing facilities from usual sources or from defects or delays in the performance of its suppliers or subcontractors due to any of the foregoing enumerated causes. In the event of delay due to any such cause, the date of delivery will be extended by period equal to the delay plus a reasonable time to resume production, and the price will be adjusted to compensate ABB for such delay.

## ABB General Terms and Conditions of Sale

16. Cancellation. Any order may be cancelled by Purchaser only upon prior written notice and payment of termination charges, including but not limited to, all costs identified to the order incurred prior to the effective date of notice of termination and all expenses incurred by ABB attributable to the termination, plus a fixed sum of ten (10) percent of the final total price to compensate for disruption in scheduling, planned production and other indirect costs.

17. Termination. No termination by Purchaser for default shall be effective unless, within fifteen (15) days after receipt by ABB of Purchaser's written notice specifying such default, ABB shall have failed to initiate and pursue with due diligence correction of such specified default.

18. Export Control.

(a) Purchaser represents and warrants that the Equipment and Services provided hereunder and the "direct product" thereof are intended for civil use only and will not be used, directly or indirectly, for the production of chemical or biological weapons or of precursor chemicals for such weapons, or for any direct or indirect nuclear end use. Purchaser agrees not to disclose, use, export or re-export, directly or indirectly, any information provided by ABB or the "direct product" thereof as defined in the Export Control Regulations of the United States Department of Commerce, except in compliance with such Regulations.

(b) If applicable, ABB shall file for a U.S. export license, but only after appropriate documentation for the license application has been provided by Purchaser. Purchaser shall furnish such documentation within a reasonable time after order acceptance. Any delay in obtaining such license shall suspend performance of this Agreement by ABB. If an export license is not granted or, if once granted, is thereafter revoked or modified by the appropriate authorities, this Agreement may be canceled by ABB without liability for damages of any kind resulting from such cancellation. At ABB's request, Purchaser shall provide to ABB a Letter of Assurance and End-User Statement in a form reasonably satisfactory to ABB.

19. Assignment. Any assignment of this Agreement or of any rights or obligations under the Agreement without prior written consent of ABB shall be void.

20. Nuclear Insurance – Indemnity. For applications in nuclear projects, the Purchaser and/or its end user customer shall have complete insurance protection against liability and property damage resulting from a nuclear incident to and shall indemnify ABB, its subcontractors, suppliers and vendors against all claims resulting from a nuclear incident.

21. Resale. If Purchaser resells any of the Equipment, the sale terms shall limit ABB's liability to the buyer to the same extent that ABB's liability to Purchaser is limited hereunder.

22. Entire Agreement. This Agreement constitutes the entire agreement between ABB and Purchaser. There are no agreements, understandings, restrictions, warranties, or representations between ABB and Purchaser other than those set forth herein or herein provided.



# Contact us

## **ABB Inc.**

ABB JOKAB SAFETY  
6471 Commerce Drive  
Westland, MI US 48185  
Phone: 888-282-2123  
Fax: 800-565-9302  
Web: [www.jokabsafetyna.com](http://www.jokabsafetyna.com)

## **ABB Inc.**

Low Voltage Products  
2117 32nd Ave.  
Lachine, Quebec, Canada H8T 3J1  
Phone: 514-420-3100  
Toll Free: 800-567-0283  
Fax: 514-420-3137  
Technical Support:  
800-567-0283  
[lv.support@ca.abb.com](mailto:lv.support@ca.abb.com)